

## CHAPTER III EXPERIMENTAL

### 3.1 Materials

#### 3.1.1 Chemicals for Catalyst Preparation

All chemicals used in catalyst preparation and analytical procedures were described as followed:

1. Titanium dioxide P25 (TiO<sub>2</sub>) was obtained from Degussa AG.
2. Hydrogen tetrachloroaurate (III) trihydrate (HAuCl<sub>4</sub>·3H<sub>2</sub>O), ACS, 49.5%, was obtained from Alfa Aesar A Johnson Matthey Company.
3. Sodium Hydroxide (NaOH) was obtained from Labscan.
4. Hydrochloric acid (HCl), AR grade of 37% was obtained from Labscan.
5. Nitric acid (HNO<sub>3</sub>), AR grade of 65% was obtained from Labscan.

#### 3.1.2 Reagent Gases for Reaction and TPD/R Experiment

All reactant gases were obtained from Thai Industrial Gas Co., Ltd. as shown below:

1. Titanium dioxide P25 (TiO<sub>2</sub>) was obtained from Degussa AG.
2. Helium (HP grade).
3. 40% Ethylene balance with Helium.
4. 97% Oxygen balance with Helium.

TPD/R reactant gases were obtained from Air Product Co., Ltd. as followed:

5. 97 % Oxygen balance with Helium.
6. Nitrogen (HP grade).
7. 5.32% Hydrogen balance with Nitrogen.

## 3.2 Catalysts Preparation Procedures

### 3.2.1 Synthesis of TiO<sub>2</sub> Nanotubes

Commercial TiO<sub>2</sub> powder (Degussa P25; a mixture of crystalline rutile and anatase phases with surface area ~50 m<sup>2</sup>/g) were used as the TiO<sub>2</sub> precursors for the wet chemical nanoparticles preparation. 2 g of the precursor was mixed with 40 ml of NaOH aqueous solution with the concentration of 10 mol/L, followed by hydrothermal treatment at 423 K in a Teflon-lined autoclave for 24 h. The treated powders were washed thoroughly with distilled water and 0.1 mol/L HCl aqueous solution until the pH value of the washing solution was lower than 7 and the solid was a white color and cotton-batting-like, and then washed carefully with distilled water to eliminate the Cl<sup>-</sup> ion. After filtration and drying at 353 K, the products were used as precursors for synthesis of Au-based catalysts.

### 3.2.2 Preparation of Gold Supported TiO<sub>2</sub>

In this research, the incipient wetness impregnation method was used to prepare the Au-doped oxide catalysts at 1% Au (Au/(Au+MO<sub>x</sub>) = 1%) in the commercial titania (TiO<sub>2</sub>; Degussa P25) and synthesized titania nanotubes. The both supports were divided into two types which are uncalcined support and calcined support at 873 K. An aqueous solution of Au precursor (HAuCl<sub>4</sub> • 3H<sub>2</sub>O, Alfa) solution with a nominal gold loading of 1% wt was added to two forms of titania support until incipient wetness was achieved. Then, the catalyst precursor was dried at 383 K overnight followed by calcinations at different temperature in the range of 473-873 K for 5 h with 10 K min<sup>-1</sup> ramping rate. After that, the catalysts are sieved in order to select grain sizes in the range of 250-425 μm for the activity studies.

## 3.3 Catalysts Characterization

The characteristics of the prepared Au-doped oxide catalysts were determined with regard to their physical and chemical properties. The characterization techniques and equipments applied in this research were BET

surface area analyzer, Atomic Absorption Spectroscopy (AAS), X-ray diffraction (XRD), Transmission Electron Microscopy (TEM), Temperature Programmed Desorption (TPD), and Temperature Programmed Reduction (TPR).

### 3.3.1 BET Surface Area Measurement

The surface areas of all prepared catalysts were determined by measuring the quantity of gas adsorbed onto or desorbed from their solid surface at some equilibrium vapor pressure by static volumetric method. The solid sample was maintained at a constant temperature of the sample cell until the equilibrium was established. This volume-pressure data were used to calculate the BET surface area.

The BET surface area measurement was done by using Quantachrome Corporation Autosorb I. The catalyst sample was first outgassed to remove the humidity and volatile adsorbents adsorbed on surface under vacuum at 423 K for ten hours before starting the analysis to determine the surface area. Autosorb ANYGAS Version 2.10 was used to analyze the results.

The adsorption data were calculated by using the Brunauer-Emmett-Teller (BET) equation.

$$\frac{P}{V(P_0 - P)} = \frac{1}{V_m c} + \frac{(c-1) P}{V_m c P_0} \quad (3.1)$$

where;

V = the volume of gas adsorbed;

P = the pressure of gas;

P<sub>0</sub> = the saturated vapor pressure of the liquid at the operating temperature;

V<sub>m</sub> = the volume equivalent to an adsorbed monolayer; and

c = the constant related to the energy of adsorption in the first adsorbed layer, the magnitude of adsorption in the first adsorbed layer, and the magnitude of adsorbate/adsorbent interaction, which is given by

$$c = \exp\left(\frac{H_1 - H_L}{RT}\right) \quad (3.2)$$

where;

- $H_1$  = the fixed heat of adsorption;
- $H_L$  = the latent heat of evaporation;
- $R$  = the gas constant; and
- $T$  = the temperature

The surface area can be determined by using the following equation:

$$S_g = \frac{V_m}{0.0224} + (6.02 \times 10^{23})(A) \quad (3.3)$$

where;

- $S_g$  = the specific surface area ( $m^2/g$ ); and
- $A$  = the area occupied by each adsorbate molecule ( $m^2$ )

### 3.3.2 Atomic Absorption Spectroscopy (AAS)

The actual contents of gold loading in the prepared catalysts were determined by an atomic absorption spectroscopy. The standard solution of 1,000 ppm of gold used in this work was manufactured by Merck. Firstly, a known weight around 0.02 g of a catalyst was completely dissolved in a mixture solution of aquaregia (hydrochloric acid and nitric acid with a ratio of 18:82). The solution was then diluted to the measuring range. The concentration of gold was obtained by comparing its absorbance with the calibration curve of the standard solution. A Varian Spectr AA-300 was employed to determine the compositions of gold in the prepared catalysts.

### 3.3.3 X-ray Diffraction (XRD)

X-ray Diffraction (XRD) is based on the fact that an X-ray diffraction pattern is unique for each crystalline substance. Thus, if an exact match can be found

between the pattern of an unknown and an authentic sample, chemical identity can be assumed. It is also possible to make a relatively quantitative analysis by comparing the intensity of the diffraction lines. When comparing the same crystalline substance of two different samples, the higher intensity shows the higher content.

X-ray diffraction patterns of all catalyst samples were obtained by using a Rigaku RINT 200C diffractometer equipped with a Ni filtered CuK $\alpha$  radiation source ( $\lambda = 1.542 \text{ \AA}$ ) of 40 kV and 30mV. A catalyst sample was pressed into a hollow of glass holder and held in place by glass window. Then, it was scanned in the range of  $2\theta$  from  $5^\circ$  to  $80^\circ$  in the continuous mode with the rate of  $5^\circ \text{ min}^{-1}$ . The XRD results gave peak parameters, including the centroid  $2\theta$ , the full line width at half the maximum of intensity ( $\beta$ ), d-value and intensity. The mean crystallite size was calculated from the XRD data from X-ray line broadening, using the full line width at half maximum of intensity and the  $2\theta$  values and plugging them into the Debye-Scherrer equation.

$$T = K\lambda / \beta \cos\theta \quad (3.4)$$

where

- $\lambda$  = the X-ray wavelength (0.1542 nm for Cu anode source);
- $K$  = the Debye-Scherrer constant which to some degree depends on the shape of the peak (assume equal to 0.9);
- $\beta$  = the full width at half maximum (FWHM) of the broadened peak;
- $\theta$  = the Bragg angle of the reflection (degree); and
- $T$  = the thickness of the crystal (nm)

This equation works well for particle sizes of less than 1,000  $\text{\AA}$ . The broadening of diffraction lines measured at half the maximum intensity ( $\beta$ ) is corrected by using Warren's method, which is

$$\beta^2 = \beta_M^2 - \beta_S^2 \quad (3.5)$$

where;

$\beta_M$  = the breadth of the diffraction line; and

$\beta_S$  = the breadth of the line from a standard.

#### 3.3.4 Transmission Electron Microscopy (TEM)

The transmission electron micrographs was employed for investigate the average particle sizes of metals and identify the microstructure of prepared catalysts such as metal dispersion, the crystalline size of Au particles on the support and titanium oxide nanotube structure also. The catalyst samples were ground into fine powder and ultrasonically dispersed in ethanol. A small droplet of the suspension was deposited on a copper grid with polyvinyl desiccate, and the solvent was evaporated prior to loading the sample into the microscope. TEM was carried out in a JEOL 200 CX operating at an accelerating voltage of 200 kv in bright field modes. A beam was passed through a series of lenses to form a magnified image of a sample that has been inserted in the area of the objective lens. The image from selected area was viewed through projection onto a view of screen. However, electron beams were easily scattered by air molecules and TEM columns must be kept under high vacuum. Additionally, the electronmagnetic lenses were used for focus the elctron beam.

#### 3.3.5 Temperature Programmed Desorption (TPD)

Temperature-Programmed Desorption (TPD) analyses were employed to determine the number, type, and strength of active sites available on the surface of catalyst samples. It can be done by measuring the amount of gas desorbed at various temperatures. After the sample had been outgassed, reduced, or otherwise prepared, a steady stream of analysis gas was allowed to flow over the sample and reacted with time while a constant stream of inert carrier gas was still passing over the sample. As it has been known that at a particular temperature, the heat will overcome the activation energy; therefore, the bond between the adsorbate and adsorbent will break and the adsorbed species will desorb. If different active metals are present, they usually will desorb the reacted species at different temperatures. The desorbe molecules enter the stream of inert carrier gas and are swept to the

detector which measures the gas concentrations. The volume of desorbed species combined with stoichiometry factor, and the temperature at which preadsorbed species desorb, yields the number and strength of active sites.

The experiment was carried out in a Thermo Finnigan TPDRO 1100 by placing 200 mg of catalyst into quartz tube reactor. The catalyst was pretreated in a flow of  $O_2$  at 473 K ( $20 \text{ ml min}^{-1}$ ) for 1 h. Then, the reactor was flushed with  $N_2$  ( $20 \text{ ml/min}^{-1}$ ) for 0.5 h in order to remove the gas phase of  $O_2$ . After that, the reactor temperature was ramped from room temperature to 973 K at a linear heating rate of  $20 \text{ K min}^{-1}$  in flowing  $N_2$  ( $30 \text{ ml min}^{-1}$ ). The desorbing oxygen was detected with a thermal conductivity detector (TCD).

### 3.3.6 Temperature Programmed Reduction (TPR)

Temperature-Programmed Reduction (TPR) will be employed for evaluating the reducibility of supported oxide catalysts quantitatively, the quantity of cationic versus auto-reduced Au on the support oxide surface and the temperature at which the reduction itself takes place as a function of the temperature.

The experiment was carried out in a Thermo Finnigan TPDRO 1100 by placing 200 mg of catalyst in to quartz tube reactor. The catalyst was pretreated in a flow of  $N_2$  ( $20 \text{ ml min}^{-1}$ ) at 473 K for 0.5 h. Then, a hydrogen-nitrogen (5.32%  $H_2$ ) was used to reduce the samples at a flow rate of  $30 \text{ ml min}^{-1}$ . The temperature was linearly raised at a rate of  $15 \text{ K min}^{-1}$  from room temperature to 1173 K.

## 3.4 Catalytic Activity Measurement

The experimental study of ethylene oxidation was conducted in a fixed bed reactor, which was operated at atmospheric pressure. Catalyst powder of 350 mg was placed inside a Pyrex tube and secured by glass wool plugs. The tubular reactor being 9 mm in diameter was placed in a furnace equipped with a temperature controller. The catalyst was initially pretreated with oxygen at 423 K for 2 h in order to diminish some impurities and remove residual moisture from the catalyst. The feed gas was a mixture of 40% ethylene in helium, pure oxygen (HP grade) and pure helium (HP grade) obtained from Thai industrial gas (TIG). The flow rates of these

three gas streams were regulated by mass flow controllers to obtain the required feed gas composition. The feed gas was passed through the reactor at a constant space velocity  $7500 \text{ h}^{-1}$  and the temperature was varied from 473 to 723 K. Feed gas composition was varied in three concentrations which are 9%  $\text{C}_2\text{H}_4$  and 13.5%  $\text{O}_2$  in He, 9%  $\text{C}_2\text{H}_4$  and 27%  $\text{O}_2$  in He and 9%  $\text{C}_2\text{H}_4$  and 54%  $\text{O}_2$  in He as a deficient, stoichiometry and excess of oxygen condition, respectively. The compositions of the feed gases and effluent gases are analyzed by using on-line gas chromatography (PERKIN ELMER Autosystem) equipped with HaYeseb D 80/100-packed column, capable of separating carbon dioxide, carbon monoxide, ethylene and oxygen. The schematic diagram of experiment setup is shown in Figure 3.1.

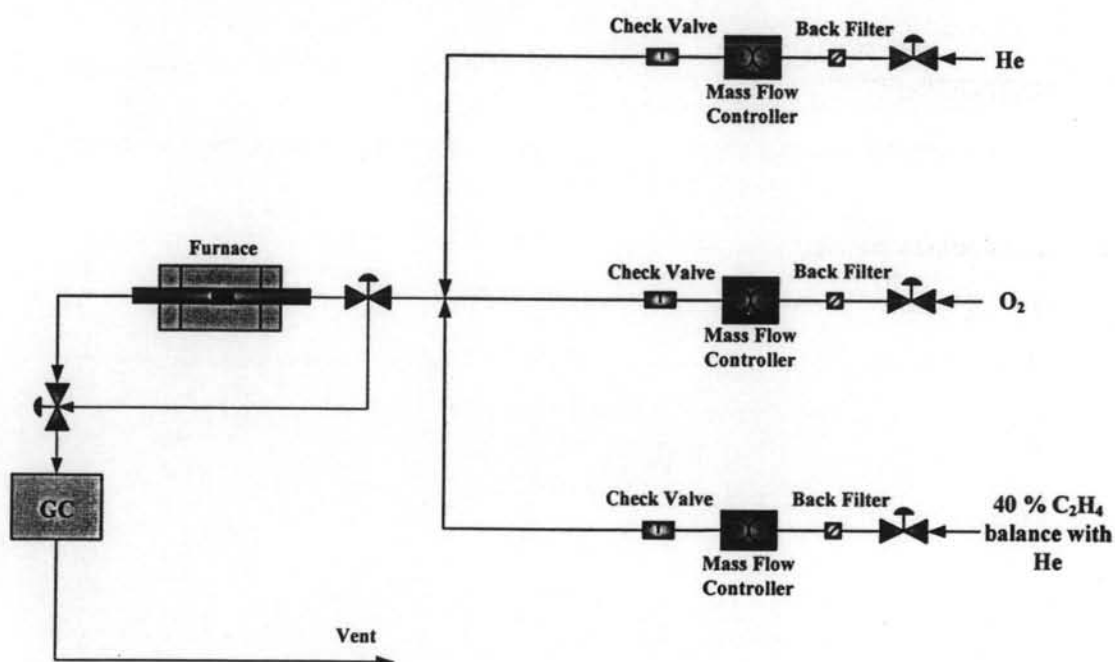

**Figure 3.1** Schematic diagram of experimental setup for ethylene oxidation.

Calculations for the ethylene conversion, ethylene oxide selectivity and yield are based on the following equations:



$$\text{Ethylene conversion } (X) = [F_{C_2H_4 \text{ in}} - F_{C_2H_4 \text{ out}}] / [F_{C_2H_4 \text{ in}}]$$

$$\text{Carbon dioxide selectivity } (S_{CO_2}) = [F_{CO_2 \text{ out}}] / [F_{C_2H_4 \text{ in}} - F_{C_2H_4 \text{ out}}]$$

$$\text{Carbon monoxide selectivity } (S_{CO}) = [F_{CO \text{ out}}] / [F_{C_2H_4 \text{ in}} - F_{C_2H_4 \text{ out}}]$$

where;

$F_{C_2H_4 \text{ in}}$  = Inlet mass flowrate of ethylene (mole/min)

$F_{C_2H_4 \text{ out}}$  = Outlet mass flowrate of ethylene (mole/min)

$F_{CO_2 \text{ out}}$  = Outlet mass flowrate of carbon dioxide (mole/min)

$F_{CO \text{ out}}$  = Outlet mass flowrate of carbon monoxide (mole/min)