

**INSTALLATION COST ESTIMATION IN
A POWER PLANT CONSTRUCTION PROJECT
BY ACTIVITY-BASED COSTING**

Mr. Tongchai Iemkanitchat

**A Thesis Submitted in Partial Fulfillment of the Requirements
for the Degree of Master of Engineering in Engineering Management**

The Regional Centre for Manufacturing Systems Engineering

Faculty of Engineering

Chulalongkorn University

Academic Year 2000

ISBN 974-13-0382-3

การประมาณต้นทุนการติดตั้งในโครงการก่อสร้างโรงไฟฟ้า

โดยใช้ต้นทุนตามกิจกรรม



นายรัชชัย เอี่ยมคณิตชาติ

วิทยานิพนธ์นี้เป็นส่วนหนึ่งของการศึกษาตามหลักสูตรปริญญาวิศวกรรมศาสตรมหาบัณฑิต

สาขาวิชาการจัดการทางวิศวกรรม ศูนย์ระดับภูมิภาคทางวิศวกรรมระบบการผลิต

คณะวิศวกรรมศาสตร์ จุฬาลงกรณ์มหาวิทยาลัย

ปีการศึกษา 2543

ISBN 974-13-0382-3

ลิขสิทธิ์ของจุฬาลงกรณ์มหาวิทยาลัย

Thesis Title INSTALLATION COST ESTIMATION IN A POWER PLANT
CONSTRUCTION PROJECT BY ACTIVITY-BASED COSTING
By Mr. Tongchai Iemkanitchat
Department The Regional Centre for Manufacturing Systems Engineering
Thesis Advisor Associate Professor Chuvej Chansa-ngavej, Ph.D.
Thesis Co-advisor Mr. Teerachai Leethochawalit

Accepted by the Faculty of Engineering, Chulalongkorn University in Partial
Fulfillment of the Requirements for the Master's Degree

..... Dean of Faculty of Engineering
(Professor Somsak Panyakeow, D.Eng)

THESIS COMMITTEE

..... Chairperson
(Professor Sirichan Thongprasert, Ph.D.)

..... Thesis Advisor
(Associate Professor Chuvej Chansa-ngavej, Ph.D.)

..... Thesis Co-advisor
(Mr. Teerachai Leethochawalit)

..... Member
(Assistant Professor Jeerapat Ngaoprasertwong)

ชงชัย เอี่ยมคณิตชาติ : การประมาณต้นทุนการติดตั้งในโครงการก่อสร้างโรงไฟฟ้าโดยใช้ต้นทุนตามกิจกรรม. (INSTALLATION COST ESTIMATION IN A POWER PLANT CONSTRUCTION PROJECT BY ACTIVITY-BASED COSTING) อ. ที่ปรึกษา : รศ. ดร. ชูเวช ชาญสง่าเวช, อ. ที่ปรึกษาร่วม : นาย ชีระชัย ลิโทชวลิต , 142 หน้า. ISBN 974-13-0382-3.

การศึกษานี้มีวัตถุประสงค์เพื่อพัฒนาวิธีการในการประมาณต้นทุนการติดตั้งงานด้านเครื่องกลในโครงการก่อสร้างโรงไฟฟ้า โดยใช้วิธีคิดต้นทุนตามกิจกรรม

การประมาณต้นทุนตามกิจกรรม เริ่มจากการใช้เทคนิค IDEF0 สร้างแบบจำลองของกิจกรรม รวบรวมค่าใช้จ่ายทั้งทางตรงและทางอ้อมของหน่วยงาน รวบรวมข้อมูลทรัพยากร และกำหนดตัวผลิตภัณฑ์ต้นทุน เพื่อสร้างรูปแบบการปันส่วนทรัพยากรไปยังกิจกรรมหรือศูนย์กิจกรรม ได้ต้นทุนต่อหน่วยของกิจกรรม แล้วจึงคำนวณต้นทุนรวมของงานติดตั้ง ซึ่งจะแปรผันตามจำนวนตัวผลิตภัณฑ์ต้นทุนของแต่ละกิจกรรมที่ต้องทำในแต่ละประเภทงาน

โดยใช้กรณีศึกษาของโครงการก่อสร้างโรงไฟฟ้าที่มีหน่วยงานติดตั้งเป็นของตนเอง แบบจำลองของกิจกรรมจะประกอบด้วย 21 กิจกรรมย่อย ภายใน 5 กิจกรรมหลัก และ 11 กิจกรรมย่อย ภายใน 5 กิจกรรมเสริม ค่าใช้จ่ายทั้งทางตรงและทางอ้อมของหน่วยงานที่รวบรวมได้จะถูกนำไปกระจายลงในทุกกิจกรรมที่ปรากฏในแบบจำลองของกิจกรรม และในทุก 20 ประเภทงานของโครงการนี้ โดยผ่านทางตัวผลิตภัณฑ์ต้นทุนทั้งหมด 25 ชนิด นำผลที่ได้ไปเปรียบเทียบกับต้นทุนที่คิดได้จากวิธีเดิม โดยใช้วิธีคิดตามกิจกรรมเป็นฐาน การเปรียบเทียบในเชิงปริมาณพบว่า 90 % ของจำนวนประเภทงาน หรือ 18 ประเภทงาน ที่ต้นทุนแตกต่างกันมากอย่างมีนัยสำคัญ ส่วนในเชิงคุณภาพพบว่า 65 % ของจำนวนประเภทงาน หรือ 13 ประเภทงาน ที่ต้นทุนแตกต่างกันมากกว่า 20 %

จากผลการศึกษาแสดงว่าระบบการคิดต้นทุนตามกิจกรรมนี้สามารถประยุกต์ใช้ได้ดีกับการประมาณต้นทุนการติดตั้งงานด้านเครื่องกลในโครงการก่อสร้างโรงไฟฟ้า เนื่องจากสะท้อนต้นทุนการติดตั้งได้ชัดเจน และสมเหตุสมผลกว่าวิธีการคิดต้นทุนแบบเดิม อย่างไรก็ตาม การประมาณต้นทุนตามกิจกรรมมีความยุ่งยากในการเก็บข้อมูลมากกว่าวิธีเดิม ดังนั้นในการศึกษานี้ จึงได้เสนอแนวทางในการใช้งานของทั้งสองระบบวิธี คือถ้าต้องการความรวดเร็วและยอมรับความคลาดเคลื่อนของราคาค่าต้นทุนได้มากกว่า 20% ควรเลือกวิธีการคิดแบบเดิม แต่ถ้าต้องการความแม่นยำและความละเอียดก็ควรเลือกวิธีการตามระบบกิจกรรม ทั้งนี้เพื่อให้ได้ประโยชน์สูงสุด และเป็นประโยชน์ในการสร้างฐานข้อมูลต้นทุนที่เชื่อถือได้ ในการประมาณต้นทุนก่อนรับงานติดตั้งในอนาคต

ศูนย์ระดับภูมิภาคทางวิศวกรรมระบบการผลิตลายมือชื่อนิสิต

สาขาวิชาการจัดการทางวิศวกรรมลายมือชื่ออาจารย์ที่ปรึกษา

ปีการศึกษา 2543ลายมือชื่ออาจารย์ที่ปรึกษาร่วม

4171608521 : MAJOR ENGINEERING MANAGEMENT

KEY WORD: ACTIVITY-BASED COSTING / CONSTRUCTION PROJECT / POWER PLANT /
INSTALLATION COST ESTIMATION

TONGCHAI IEMKANITCHAT: INSTALLATION COST ESTIMATION IN A POWER
PLANT CONSTRUCTION PROJECT BY ACTIVITY-BASED COSTING. THESIS
ADVISOR: ASSOC. PROF. CHUVEJ CHANSA-NGAVEJ, Ph.D., THESIS COADVISOR:
MR. TEERACHAI LEETHOCHAWALIT, 142 pp. ISBN 974-13-0382-3.

The objective of this study is to develop a cost estimation methodology using Activity-Based Costing or ABC approach for the mechanical installation works of a power plant construction project.

The first phase of the study is to perform activity analysis by using IDEF0 technique and analyse the direct and indirect cost of the organisation and gather resource driver information. The second phase is to develop a conceptual framework model to attribute costs to activities or activity cost pools and perform cost object analysis. The last phase is the gathering activity driver information and identifying activity cost driver to attribute activity costs to cost objects.

The study found that the operational function of the case project consisted of 5 macro activities and its 21 micro activities, whereas the supporting function comprised 5 macro activities and its 11 micro activities. The captured overhead costs are allocated to the entire activities and the 20 cost objects or work packages by its corresponding 25 activity cost drivers. Having compared the cost per cost object under the traditional and the ABC estimating method to evaluate the extent of cost distortion caused by the traditional method, it was quantitatively found that 18 out of all packages or 90% were significantly deviated, while the qualitative evidence illustrated that 13 out of all packages or 65% were distorted by more than 20% of cost variance.

This means that the ABC approach could not only be usefully applied to estimate the installation cost of the mechanical work, but it also provides more reasonable and clearer cost information than the traditional system. Nevertheless, the ABC requires far more time and resource than the existing system in terms of its information acquisition and investment. Therefore, in order to enhance the effective use of the two systems where possible, the traditional system should be considered as the estimation method when time is the constraining factor, while the ABC should be required when accuracy is the limiting factor within the maximum 20% of cost variance.

The Regional Centre for Manufacturing Systems Engineering Student's signature.....

Field of study Engineering Management Advisor's signature.....

Academic year 2000 Co-advisor's signature.....

Acknowledgement

The author is very much obliged to Associate Professor Dr. Chuvej Chansa-ngavej, the Thesis Advisor, for his kind suggestions and advice in facilitating the completion of thesis.

The author also would like to express his sincere thanks to Professor Dr. Sirichan Thongprasert, the Chairman of the Thesis Committee, and Assistant Professor Jeerapat Ngaoprasertwong, member of the Thesis Committee, for their kind and constructive suggestions toward the studying.

Great appreciation goes out to Mr. Teerachai Leethochawalit, the Thesis Co-advisor, as well as other colleagues who had shared opinions with the author, and furnished the necessary data and information for the writing of this Thesis.

Moreover, the author is very much indebted to the case organisation for the full scholarship.

Last but not least the highest appreciation is due to my beloved parents and family.

สถาบันวิทยบริการ
จุฬาลงกรณ์มหาวิทยาลัย

Contents

	Page
Abstract (Thai)	iv
Abstract (English)	v
Acknowledgement	vi
Contents	vii
List of Tables	xii
List of Figures	xv
List of Equations	xvii
Chapter 1 Introduction	1
1.1 Background of the Project.....	1
1.1.1 Past Industry Structure	1
1.1.2 Current Industry Structure.....	2
1.2 Statement of the Problem	3
1.3 Objective	4
1.4 Scope of the Study.....	4
1.5 Expected Results	4
1.6 Methodology	5
Chapter 2 Theoretical Considerations	8
2.1 Activity Based Costing.....	8
2.1.1 The use of ABC.....	8
2.1.2 ABC Methodology	9
2.1.2.1 Perform Activity Analysis.....	11
2.1.2.2 Gather Cost Data	13
2.1.2.3 Tracing Costs to Activities.....	15
2.1.2.4 Identify Output Measures.....	16

Contents (continued)

Chapter	Page
2.1.2.5 Developing Output Measures.....	16
2.2 Activity Modeling	17
2.2.1 IDEF0	18
2.2.1.1 IDEF0 model.....	19
2.2.2 Determining Activity Costs Using IDEF0	19
2.2.3 Refining IDEF0 Activities	20
2.3 Literature Survey.....	20
Chapter 3 Activity-Based Cost Estimation System	28
3.1 Introduction	28
3.2 Activity Analysis.....	28
3.2.1 Work Breakdown Structure.....	28
3.2.2 IDEF0 Activity Modeling	29
3.2.2.1 IDEF0 of the Installation Process.....	31
3.3 Cost Analysis.....	41
3.3.1 Scope of Cost Data.....	41
3.3.2 Identify Organisational Cost Structure.....	42
3.3.3 Cost Information Gathering.....	42
3.3.3.1 Manpower.....	42
3.3.3.2 Supplies	47
3.3.3.3 Rental Equipment.....	52
3.3.3.4 Rental Heavy Equipment.....	52

Contents (continued)

Chapter	Page
3.3.3.5 Facilities	53
3.3.3.6 Miscellaneous Expenses.....	54
3.4 Develop Cost Flow Model	55
3.4.1 Perform Cost Objects Analysis	56
3.5 Gather Resource Driver Information.....	59
3.5.1 Manpower.....	59
3.5.2 Supplies	67
3.5.3 Rental Equipment.....	67
3.5.3.1 Cars.....	67
3.5.3.2 Computer & Accessories.....	71
3.5.3.3 Copy machine.....	71
3.5.4 Rental Heavy Equipment.....	73
3.5.5 Facilities	73
3.5.6 Miscellaneous Expenses.....	77
3.6 Activity-Based Cost Allocation.....	84
3.6.1 Stage-One Cost Allocation.....	84
3.6.1.1 Identify Category of Functional Elements	84
3.6.1.2 Attributing all overhead costs to activity cost pools	85
3.6.2 Stage-Two Cost Allocation	92
3.6.2.1 Identifying activity cost drivers.....	92
3.6.2.2 Gathering activity driver information.....	94

Contents (continued)

Chapter	Page
3.6.2.3 Obtaining activity driver rates.....	94
3.6.2.4 Tracing Costs to Cost Objects.....	97
Chapter 4 Comparative Analysis and Evaluation.....	101
4.1 Introduction	101
4.2 Conventional System at MPD	101
4.2.1 Step One of Single-Based Allocation.....	102
4.2.1.1 Tracing Cost to Functional Cost Elements.....	102
4.2.2 Step Two of Single-Based Cost Allocation.....	102
4.2.2.1 Reattribute Service Costs to Operation Elements	102
4.3 Comparative Analysis	105
4.3.1 Conceptual Comparison	105
4.3.2 Cost Variances Analysis.....	107
4.3.2.1 Calculations.....	107
4.3.3 Evaluation Criteria	108
4.3.3.1 Quantitative criteria.....	108
4.3.3.2 Qualitative Criteria.....	111
4.4 Comparison Results.....	111
4.4.1 Quantitative Results	112
4.4.2 Qualitative Results	113
4.5 Costing Report.....	114
4.6 Model Evaluation	115

Contents (continued)

Chapter	Page
4.6.1 Appropriateness of ABC	115
4.6.2 Benefit of ABC.....	115
4.6.3 Discussion and Limitation of ABC	116
Chapter 5 Conclusion.....	118
5.1 Conclusion.....	118
5.2 Recommendation.....	120
References	122
Appendices	124
Appendix A: Project Erection Schedule.....	125
Appendix B: Example of Costing Reports.....	133
Biography.....	142

 สถาบันวิทยบริการ
 จุฬาลงกรณ์มหาวิทยาลัย

List of Tables

Table	Page
Table 2-1	The uses of ABC..... 9
Table 3-1	Mechanical installation activities for SCPPCP..... 32
Table 3-2	The identification of cost structure details and its criterion of the case project..... 43
Table 3-3	The midpoint salary, site allowance and overtime criteria for each employee in the case project..... 46
Table 3-4	The standard rates of welder and crane operator skill premium.... 47
Table 3-5	Total individual manpower costs of the personnel of the MPD who worked for this project..... 48
Table 3-6	The percentage of effort time allocation of this project on each personnel by each functional element..... 61
Table 3-7	Total working time of each functional element within the project schedule..... 65
Table 3-8	Total manpower cost for each of cost object..... 66
Table 3-9	The percentage of supplies usage and total supplies cost of each functional element..... 68
Table 3-10	The percentage of usage time allocation on each functional element by each rental car of this project..... 69
Table 3-11	Total rental equipment cost of each functional element..... 72
Table 3-12	The heavy equipment usage time and total cost of each functional element of this project..... 74
Table 3-13	The facilities cost of each functional element in this project..... 76
Table 3-14	The percent of miscellaneous usage and its cost distribution of each functional element of this project..... 78
Table 3-15	The overall miscellaneous cost that distributed on each of functional element..... 82

List of Tables (continued)

Table	Page
Table 3-16 Overall overhead costs and its total cost in each of functional element of this project.....	83
Table 3-17 The categories of each functional element of this project.....	86
Table 3-18 Percentage of time allocation on each of operational cost object by each of activity cost pool.....	88
Table 3-19 Final cost distribution on each operational cost object by each activity.....	90
Table 3-20 Managerial (Project Management) and Support (Material Supply) costs distribution on it related activities.....	91
Table 3-21 Identifying of the activity drivers, its total volumes and activity driver rates for each of activity cost pools.....	93
Table 3-22 Capturing of the activity driver volumes for each of the cost object in the case project.....	95
Table 3-23 Tracing all overhead costs to the of cost objects no. 0411 of this project.....	98
Table 3-24 Tracing all overhead costs to all of the cost objects of this project.....	99
Table 4-1 Step two of single-based cost allocation or direct method in traditional system at MPD.....	104
Table 4-2 Conceptually comparison between Old and ABC system at MPD.....	106
Table 4-3 Analysis of cost variance occurred by the traditional system.....	110

List of Tables (continued)

Table	Page
Table 4-4 Qualitative criteria of distortion occurred by the old system, represented as a difference from ABC cost.....	111
Table 4-5 Distortion analysis occurred by the Old System, depicted as a percent difference from ABC cost.....	112
Table B-1 Ranking of activity cost by its value.....	134
Table B-2 Activity Cost Report by identifying activities, its activity cost drivers and overhead rates.....	135
Table B-3 Activity-Based Costs Estimation Report for Cost Object No. 0411 (Alignment Check).....	136
Table B-4 Cost per Cost Object Report.....	138
Table B-5 Comparison of results between the four sources of activity driver rate that used to calculate the Turbine installation activity cost (cost object no.0411).....	141

List of Figures

Figure		Page
Figure 1-1	The ABC estimating Methodology.....	6
Figure 2-1	The process of Two-Stage Coat Allocation of ABC.....	10
Figure 2-2	A typical IDEF0 Model.....	18
Figure 2-3	The node tree diagram of determining activity costs.....	19
Figure 3-1	Project work breakdown structure for the construction of the simple cycle power plant.....	30
Figure 3-2	The AO Node for the mechanical installation activities of the Simple Cycle Power Plant Construction Project.....	33
Figure 3-3	The A1 Node for the Advance Planning activities of the Simple Cycle Power Plant Construction Project.....	34
Figure 3-4	The A2 Node for the Equipment Receiving activities of the Simple Cycle Power Plant Construction Project.....	35
Figure 3-5	The A3 Node for the Foundation Preparing activities of the Simple Cycle Power Plant Construction Project.....	36
Figure 3-6	The A4 Node for the Lifting On-Base activities of the Simple Cycle Power Plant Construction Project.....	37
Figure 3-7	The A5 Node for the System Piping activities of the Simple Cycle Power Plant Construction Project.....	38
Figure 3-8	The A6 Node for the System Cleaning activities of the Simple Cycle Power Plant Construction Project.....	39
Figure 3-9	The A7 Node for the Painting and Insulating activities of the Simple Cycle Power Plant Construction Project.....	40
Figure 3-10	High level of Conceptual Cost Flow Model of this project.....	56
Figure 3-11	The organisational structure of the MPD.....	57
Figure 3-12	The project team organisational structure of the Simple-Cycle Power Plant of MPD.....	58
Figure 3-13	Time allocation of each personnel in each functional element.....	60
Figure 4-1	Traditional method by Single-Base Cost Allocation at MPD.....	102
Figure 4-2	The overall comparison of cost of each package between Traditional and ABC method.....	109

List of Figures (continued)

Figure		Page
Figure 4-3	Quantitative results of the distortion between traditional and ABC system.....	113
Figure 4-4	Qualitative results of the distortion between traditional and ABC system.....	114
Figure A-1	Mechanical Erection schedule of the SCPPCP.....	125
Figure B-1	Proportional of the entire cost elements of the project.....	137
Figure B-2	Cost per Cost Object Comparison Report by its quantitative results of the distortion between traditional and ABC.....	140
Figure B-3	Cost per Cost Object Comparison Report by its qualitative results of the distortion between traditional and ABC.....	140



 สถาบันวิทยบริการ
 จุฬาลงกรณ์มหาวิทยาลัย

List of Equations

Equation		Page
Equation (1)	Monthly Manpower Cost.....	60
Equation (2)	Total Manpower Cost.....	64
Equation (3)	Monthly Rental Equipment Cost.....	69
Equation (4)	Total Rental Equipment Cost.....	71
Equation (5)	Monthly Facility Cost.....	75
Equation (6)	Total Facility Cost.....	77
Equation (7)	Monthly Miscellaneous Expenses.....	80
Equation (8)	Overall Miscellaneous Expenses.....	81
Equation (9)	Activity Cost Driver Calculation.....	94
Equation (10)	Total Allocated Cost Calculation of Direct Method.....	105
Equation (11)	Cost Variance Calculation.....	107
Equation (12)	Percentage of Cost Variance Calculation.....	107

สถาบันวิทยบริการ
จุฬาลงกรณ์มหาวิทยาลัย

Chapter 1

Introduction

1.1 Background of the Project

1.1.1 Past Industry Structure

Since 1969, the initial overall structure of the electricity generating industry in Thailand was managed by the state enterprise namely the Electricity Generating Authority of Thailand (EGAT). On behalf of the government's representative, EGAT is a key mechanism in providing, generating and distributing electricity power throughout the country.

Since then the industry has altered substantially as a result of change in terms of power plant expenditure, change in social attitudes, consumer demands and the threat of imported power.

Moreover, it was very important to respond to the government policy. The government has drawn up a rigid agenda to implement the restructuring and privatisation program that was presented in the 05 March 96 Memorandum on Economic Policies.

For the energy sector concerning EGAT the strategies were classified and summarised into two stages as defined below.

- **The Medium Term Strategy (1996 – 1998):** One of the main results from the master plan is for the state enterprise to be restructured and privatised. This plan is comprised of four strategic groups i.e. Co Generation producers; Small power Producers (SPPs); Independent Producers (IPPs); and the partial privatisation of EGAT power plants.

- **The Long Term Strategy (2000s – 2005 Onwards):** The main objective of this plan is for the further of full privatisation and the future role of the state enterprise (EGAT) in these proceedings.

1.1.2 Current Industry Structure

Focusing on the new structure of the electricity generating industry in Thailand which will comprise the Co Generation Producers, Small Power Producers (SPPs), Independent Power Producers (IPPs) and the partial privatisation of EGAT power plants. These four groups are still effected by the same factors that had been in effect in the past structure. In addition, during the extreme recession of the world economy in mid 1997, especially in Thailand, the industry has changed consequently in terms of:

- Currency exchange rates
- Decrease in consumer demand
- Decrease of foreign investment and etc.

In short, the current situation has seen the major trends directly effecting the following:

- Power plant expenditure of private sector
- Highly competition within the single market
- New Industrial composition

These trends have influenced the industry competition through the forces in the industry structure. By considering this impetus, the case organisation should critically evaluate its operations and management plan in order to sustain it competitive advantage.

Moreover, the same pressure has increased the business cost for many companies and forced the case organisation to revise its investment plan in various projects by giving priorities to those that have the potential high returns. Not only that, it results in canceling and delaying of certain projects as well.

1.2 Statement of the Problem

Ratchaburi Power Plant Construction Project (RPPCP) was established by EGAT in 1997, in order to construction, erection, inspection, testing and commissioning the 2 units of each 700 MW Ratchaburi Thermal Power Plants, 3 blocks of each 600 MW Ratchaburi Combined-Cycle Power Plants, and its common facilities. It is one clearly example of the major projects that are directly influenced by those substantial changes in terms of currency exchange rates and decrease in consumer power demand.

So, in dealing with such a large and complex engineering-based construction projects under this crisis environment. Project management should be able to assess project objectives (i.e. performance, costs, or time) in associate with project status and then make timely strategic decisions in fast responding to change. They need to understand the several of arbitrary things that can cause a project to be monitored and controlled. For instance, the following are the few things that can cause a cost overrun to the project.

- Technical difficulties require more resources.
- The scope of the work increases.
- Initial bids or estimates were too low.
- Traditional financial report was poor or untimely.
- Budget was inadequate.
- Corrective control was not exercised timely.

Unfortunately, at the Ratchaburi Power Plant Construction Project (RPPCP) of EGAT, the following are the facts that project management are faced with:

- Most of the problems discussed above are found.
- Even though the traditional cost systems possess a wealth of information pertaining to project status, they cannot readily utilise accounting data for operations based reporting.
- Job/ Contract costs are often so inaccurate, management is encouraged to allocate overhead rather than strive to eliminate waste and improve project performance.
- Still another problem is in estimating accurate cost or in determining the proper amount of overhead cost to assign to each product or service provided. Since, the

traditional accounting method does not allocate overhead cost to each service provided.

Therefore, the crucial issue that immediately calls for the monitoring and control by the project manager in this case, is the cost management system that can particularly analysis, estimating and reporting more accurate cost of activities. One useful model for RPPCP is the Activity-Based Costing (ABC) that can help in better evaluating the process of project management activities than the traditional cost accounting systems.

1.3 Objective

The objective of this study is to develop a cost estimation methodology using ABC approach for the mechanical installation works of gas turbine with generator and its auxiliary system of RPPCP, EGAT.

1.4 Scope of the Study

The scope of the study is as follows:

- The case project in this context is concerned only with the mechanical installation work of 200 MW Gas Turbine with generator and its auxiliary system that known as ‘Simple Cycle Gas Turbine Power Plant’ at RPPCP, EGAT.
- The financial period being examined is the entire cost of the case project which may be thought of as a collection of the activity costs from the beginning of the mechanical installation works until the completion in each of the subsystem packages necessary to be released for commissioning work.

1.5 Expected Results

There are three main areas of the expectation as a result of this study:

- Supporting Decisions Making: The more accurate in estimating installation costs reported by Activity-Based Costing system is the better in improving financial management, including commercial decisions making. Since, it can provide a useful information that help in effectively monitoring and control of target outcomes;
- Improving Installation Activities: It can identify not only the value added and non-value added by activities, but also an opportunities to reduce overhead costs

through a comprehensive understanding of costs, resources allocation and related dynamics; and

- Piloting Other Projects: This thesis will be possible to use as a pilot project for the other project of EGAT that may need to be analysed their cost by using ABC.

1.6 Methodology

The basic concepts of ABC are very important in this study. There are four key “ABC terms” that are helpful in learning and using ABC and in sharing experience with other practitioners: resources; activities; cost objects; and drivers. The methodology in this study has 3 major phases:

- Phase I: Costing activities;
- Phase II: Costing cost objects; and
- Phase III: Costing Reports.

In addition, as shown in figure below it should be able to achieve those phases through the following steps:

1. Perform activity analysis: In this step the overall installation activities of the RPPCP should be investigated by using IDEF0 technique at the context level. Not only the mechanical installation activities that would then be analysed and decomposed, but in the mean time, the cost object of the study could be also examined and identified.
2. Perform cost analysis: Resources are economic elements directed to the performance of activities. They are the sources of cost. Resources in the mechanical installation works of RPPCP should be examined by starting at the costs accounting data from the General Ledger (hereunder GL).
3. Develop conceptual framework model: This is the design of the ‘cost flow model’ where the structure of the system is created to meet the system objective by providing the right kind of information at the right level of detail.

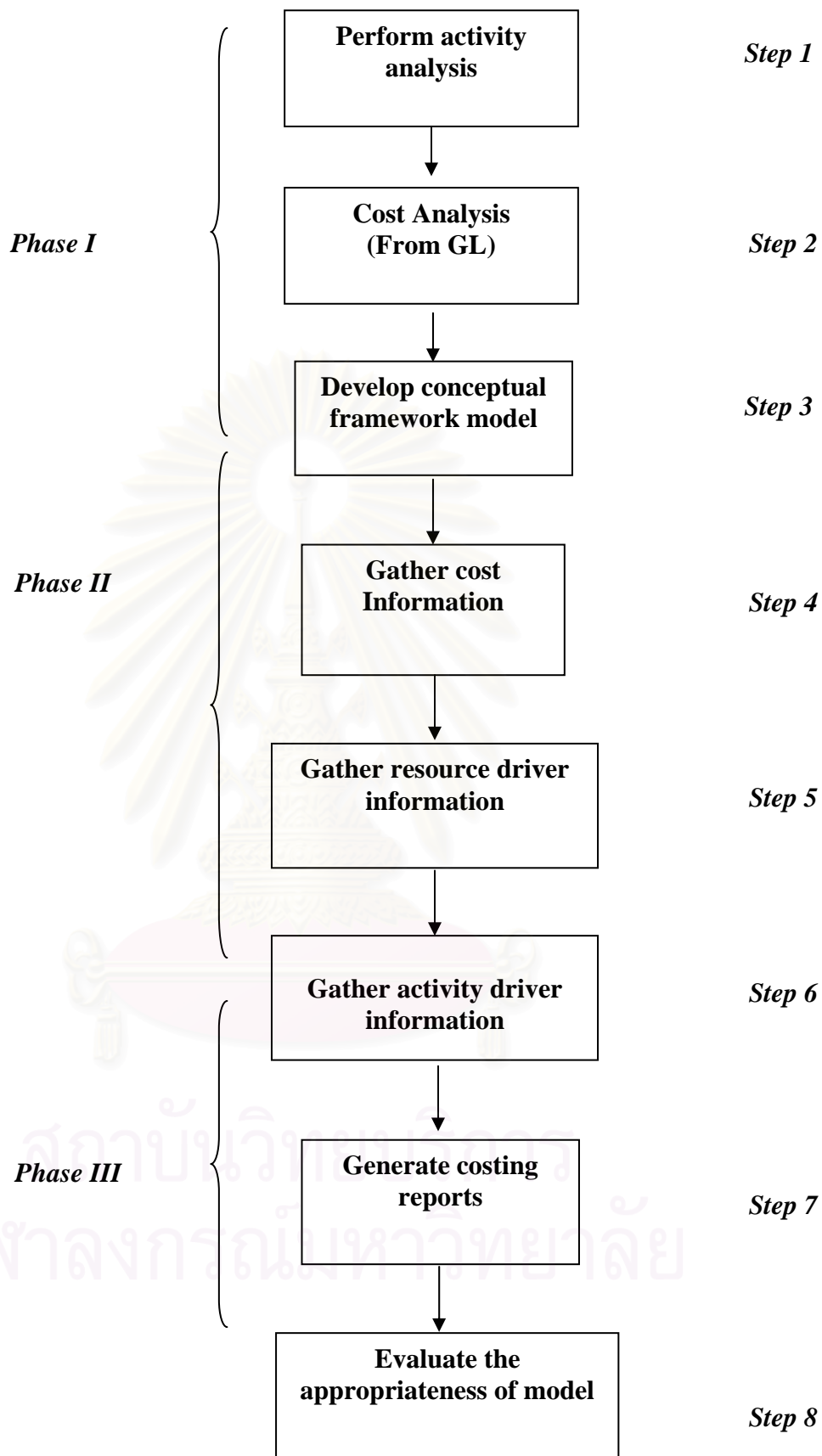

Figure 1-1: The Activity-Based cost estimating methodology.

4. Gather cost information: This is to examine the cost structure to ensure that only relevant costs are included. Moreover, the case project's organisation chart based on the cost centre information in the GL should be summarised by using Work Breakdown Structure (hereafter WBS).
5. Gather resource driver information: In order to attribute costs to activities, a 'resource driver' should be examined by measuring the quantity of resources consumed by an activity. An example of a resource driver is the 'percentage of effort' that project spends across the various activities performed.
6. Gather activity driver information: In order to attribute activities costs to 'cost object', the 'activity driver' or 'cost driver' should be investigated by measuring how often those activities are performed for each type of 'cost object' and the effort concerned in carrying them out. An example of a 'cost driver' is the 'number of assembly hours'. However, this study will be defined the 'cost driver' based on the discussion with a cross section of experience staff within the case organisation.
7. Generate a costing reports: The following three key reports can be used to support the project management in the decision making of cost management, financial management, and/or commercial issue. Moreover, the 'Activity unit cost and benchmarking report' is prepared in order to examine the appropriateness and the accuracy of the costing model that developed by this study.
 - (1) 'Activity cost report' that summarises a cost per activity;
 - (2) 'Cost per cost objects report' that evaluates a cost per cost object; and
 - (3) 'Activity unit cost and benchmarking report' that examines each of the activity unit cost of the case project in comparison with two other unit costs i.e. the 'Average unit cost' and the 'Best practice unit cost'.
8. Evaluate the model: The appropriateness of the methodology proposed by this study should then be evaluated in comparing with the traditional system.

Chapter 2

Theoretical Considerations

2.1 Activity Based Costing

Activity Based Costing or ABC is one of the world-wide means that can be used to solve problems, which traditional costing system cannot make them satisfied. Since, it is an essential part of the functional process improvement and reengineering effort by gathering quantified cost and effort time data, then interpreting this into a strategic information. ABC measuring activity or process and its corresponding performance, determining the cost of business process outputs, and identifying opportunities to improve process efficiency and effectiveness.

ABC is a tool for quantitatively measuring the cost and performance of processes, activities, resources, cost objects, products or services. This including gathers organisational overhead costs in terms of its associated production factors and service expenses and allocates then into the defined bill of activities or activity model. Although the method has some extent of complication, it is a powerful tool for measuring business performance, determining the cost of business process outputs and as a means of identifying opportunities to improve business process effectiveness and efficiency.

2.1.1 The use of ABC

Activity information can be applied in several ways by tracing the activities to the reporting objectives, which depend on the scope and objectives of the cost control and management. Brimson (1991: 156) summarised the several strategic decisions or the beneficial uses of reporting objectives as list in Table 2-1 below.

On the other hand, ABC was seen its limitation of use as discussed by CIMA members as summarised in the next section 2.3.

However, it can be seen from Table 2-1 that ABC provides a meaningful and opportunities to identify activity cost along several dimensions. Therefore, the use of ABC enhances the analysis of selected objectives or decision by gathering and

interpreting the organisational costs and allocating those costs data into the activity structure.

Table 2-1: The uses of ABC (Source: Brimson, 1991:156).	
Decisions	Focus
Cost control	Predictive cost and performance
Make/buy	Predictive cost and performance/ Vendor price& performance/ Risk
Estimating	Predictive cost and performance
Pricing	Product cost/ Target cost
Investment analysis	Cost &benefit of new process/ Risk
Manufacturing planning and control	Resource allocation and constraints
Design to cost	Predictive cost and performance
Location analysis	Differences in factors of production cost
Product line analysis	Predictive cost and performance /Product line cost
Marketing mix	Advising, promotion, selling
Salesperson	Performance, evaluation, compensation plan
Channels of distribution	Type of activity
Abandonment analysis	Predictive cost and performance /Product line cost
Customer	Volume or order size
Budgeting/forecasting	Corporate goals Predictive cost and performance with varying levels of support
Acquisitions/divestitures	Strong &weak activities /Forecast of demand for activities

2.1.2 ABC Methodology

It is important to understand the basic of ABC method that how cost accounting systems have used to allocate costs among departments. O'guin (1991: 41) and Atkinson et al. (1995: 291) stated that the ABC method that used to allocate costs among departments is breakdown into main stages as called Two-Stage Cost Allocation. The following diagram depicts the conceptual of Two-Stage Cost Allocation method of ABC system.

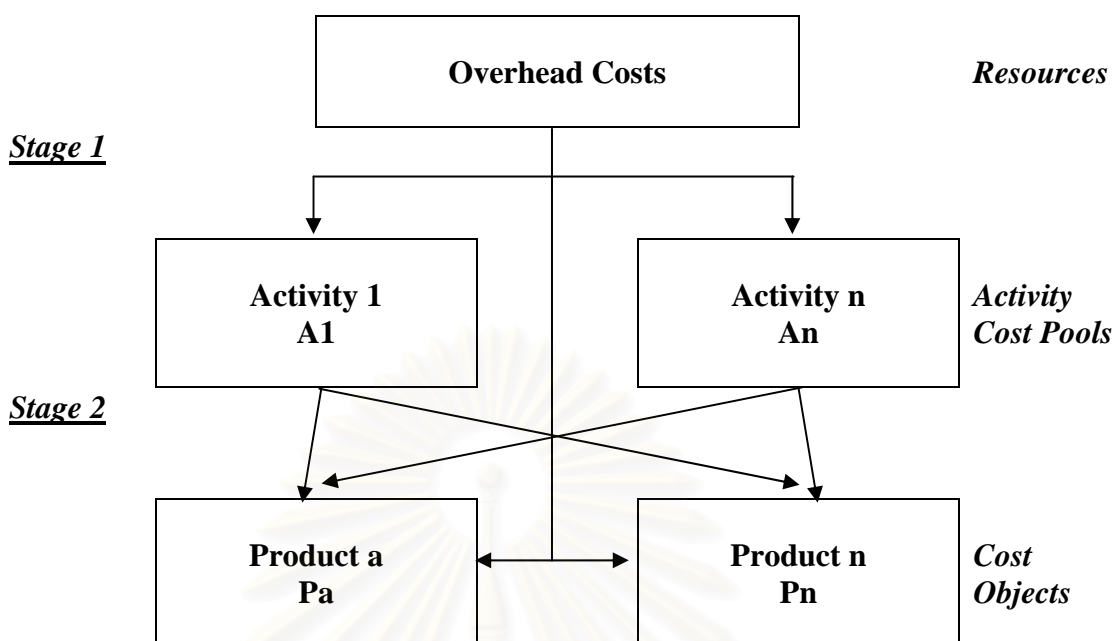

Figure 2-1: The process of Two-Stage Cost Allocation of ABC system.

Source: Reprinted from O'guin (1991: 42) and Atkinson et al. (1995: 279).

- Stage-One Cost Allocation:** At this stage, the essential objective is to trace all overhead costs of an organisation to the main production or business processes called 'activity cost pools' or 'activity centres' corresponding with its individual 'activity cost drivers'. In order to do that the various key steps should be performed. The procedures include performing activity analysis, gathering overhead cost data, gathering resource driver data, and tracing cost to activity.
- Stage-Two Cost Allocation:** After tracing all overhead cost to activity cost pools. The essential objective of this stage is to allocate activity cost pool to jobs or products based on its corresponding 'activity cost driver' rates. The procedures involve identifying activity output measures or 'activity cost driver', gathering activity driver information and then allocating cost to jobs or products.
- Develop Cost Flow Model:** In addition to the concept of two-stage cost allocation, one interesting point should be very useful for the costing system. This is according to "A Study to Develop a Costing Methodology for the Australian Higher Education Sector" by Commonwealth Department of Employment (2000), which suggested that in the implementation process of

ABC, designing the cost flow model is a crucial stage, since the model will illustrate the structure of the system with the right kind of information and the proper level of details. This means that a general flow of cost data from the organisation to an activity is done as a series of distributions and allocations. Moreover, each cost element of an organisation that was identified must now be divided to the appropriate portion of that organisation and then allocated to the activity model.

Having understood the basic concept and its procedure of two-stage cost allocation in ABC system, it should be considered how to apply those two stages in some more details as following.

2.1.2.1 Perform Activity Analysis

This is the first key step of stage-one cost allocation of the ABC system i.e. perform activity analysis. An activity is a unit of work performed within an organisation that consumes resources. Assembling part is an example of an activity within a factory.

Scope of the Activity Model

The scope or objectives of the costing project drive the level of detail required. After determining the objectives and reviewing of the business or functional process. The next step is to decide that extent to what the organisation will be affected, since it is critical to the success or failure and accuracy of the ABC allocations. It must not only be decided how large the activity scopes will cover, but also determine whether a given activity is value or non-value added, primary or secondary.

A narrowly activities defined or too much in details may complicate the overall analysis without any useful information. However, it is easier to develop an understanding of activities by means of the natural process of doing business.

A full organisation or "enterprise" model is the best approach when there is time and capability within the team.

If there is a total enterprise model from which to capture and assign costs, the entire ABC process becomes much easier for the activity accountant. In the later stages of the process, it will be clearly seen that overhead is the most difficult portions of costs to capture and distribute and it would become even more difficult when there is no basis for allocating costs from the total organisation's accounting system into a partial model.

Developing the Activity Model

The development of the activity model is not included as an integral part of the traditionally cost accounting structure, then cost allocation cannot undertake with it, hence it is the first step, and therefore, necessary to the activity account.

An activity model is a tool to assist in understanding and defining the organisation since it realigns the resources and managerial effort along the actual functions of the organisation rather than the structure of the organisation elements. The basic modeling techniques for functional process is IDEF0 for process modeling, whereas the data modeling uses IDEF1X as the basic techniques.

To develop the activity model, the project team should possess subject area knowledge of the organisation. Then surveys, workshop, and interviews with other personnel and experts within the organisation and from other available or relevant information, such as existing documents or results of previous information.

In the later stages of ABC when costs and costs drivers are under development for each of the activities, the elemental understanding becomes very critical because it provides opportunities to ask for more complete definitions of terms and activities at the time that they are created.

Analysed Activity

An activity which is identified in a process flow or activity model represents all of the effort that it takes to perform the identified task by subdividing into subordinate activities, which will enhance detailed understanding and further define the work done to complete this task.

Within the process flow or activity model there are an interaction of activity with each other. By transforming 'inputs' (resources, materials or information) from an activity or outside the organisation and then generating 'outputs' (products or information) that are used by other activities or customers. In the means time, 'outputs' are produced by using 'mechanism' under 'controls' factors (designed restrictions or standards). The Department of Defense of US (1995) stated that "*An activity is the transformation of inputs into outputs performed by mechanisms under the constraints set by controls*".

2.1.2.2 Gather Cost Data

This step is usually performed at the same time with the activity analysis step that result in reducing the study time. It will gather all relevant expenses that relate to the selected model and processes, which includes;

Scope of Cost Data

The scope of the activity model and processes discussed above will help to identify the scope of the data required. For the partial model, it will be all direct costs for the selected activities plus some portion of the total overhead costs. When selecting the data and the source to be used, it is important to call for the expertise agreement.

Objective

Costs are usually allocated based on interviews with managers on the functions and estimates become more reliable when managers are closer to the actual work. Therefore, the objective is play a key role to align cost data at the operational level of organisational element, which will lead to more easier when allocating costs in the activity model.

Planning

Two basic points relating to planning of the data gathering process that should be evaluated. First, when to begin data gathering, the actual organisation costs can begin as soon as the scope of the activity model is determined. Secondly, the amount of time that will be appropriate and sufficient for data collection: The best time frame to look for an appropriate and sufficient amount of data is the first previous full fiscal year and, when possible, the two previous full fiscal years.

Sources

The major source of cost data would be the accounting records, but they are not the only source as there are lots of meaningful information available throughout the business including:

- Accounting Records: There are various kinds of accounting records such as business accounting, budgetary account and traditional cost accounting.

- **Cost Accounting:** The usable data of the old system is for example, the greatest benefit will be that indirect costs will be identified separately and are available for distribution into either cost centers or business functions.
- **Organisational Accounting:** The business function accounting system will have direct costs associated with its function. Overhead costs typically will be allocated to a single element within the business in order for control and payment, which could be more than one element.
- **Budgetary Records:** There will be budgetary records maintained separately from the accounting systems. The indirect costs normally budgeted to a single location rather than divided.
- **Miscellaneous Records or Reports:** Business will have various records or reports from the past performance, which may be stored in the record database such as specific costs or the usage of major pieces of equipment.

Categories

There are many categories of costs that must be captured and identified. This objective is to determine the best set of meaningful and comparative data that available in the existing data sources. The main categories of costs are including:

- **Personnel:** There are two elements of data of the labor force to be determined, number of employees and cost of labor. Labor cost is the most significant variable expense of the business, which may be as much as 60% to 80% of the total business costs. There are several factors that possible to be taken into account when gathering the cost of labor as discussed below:

Salaries and Hourly Wages: The actual amount of salaries from the accounting system is usually the best source. The basic salary or yearly wages is the largest cost of the personnel. If for any reason that it cannot be subdivided, a standard payroll rate by grade and classification for the actual employee strength may be used.

Pay Increases: This represents the best known cost for the periods under consideration.

Fringe Benefits: Fringe benefits is normally calculated as a percentage of the basic personnel cost.

Overtime: Overtime must be analysed before it is used in the calculation. Overtime spent for emergencies and one-time events should not be included, since this will overstate the true cost of continuing operations.

Vacancies: Unfilled positions of the past normally should not be taken into consideration since there will always be some positions in the business that are free.

- **Direct materials**: This type of materials is used in the direct production, which are not difficult to calculate but should not be redundant with supplies costs.
- **Supplies**: This type of costs for supplies is normally easy to find, as it is one of the categories that management typically tries to keep under control. The only difficulty may be that the amounts are not divided down to the lowest level of the business.
- **Rental Equipment**: This kind of expense is a variable expense that can be readily eliminated with business changes. If more than one element makes primary use of equipment, it will be allocated based on its usage.
- **Facilities**: To represent the cost of using the facility, the depreciation could be the type of cost of facilities that are distributed. However, for the maintenance cost and facilities sustaining cost are usually captured in overhead expenses.
- **Overhead Expenses**: These types of cost must be identified for applicability and a relationship, such as utilities, maintenance, security, etc. Since many used of the accounting systems tend to merge these costs or pay them centrally, there are often problems with defining and documenting separate amounts by type.

2.1.2.3 Tracing Costs to Activities

As results of gathering costs, those cost then traceable to activity cost pools as identified by activity analysis. Though it is a difficult mathematical equation but this allocation procedure will require the full measure of analytical skill and experience from the team members. Since, they represent the best selection costs, decide the procedural priorities, and track appropriate organisational costs to every activity. Each activity will transform inputs represented by resources into outputs that are incurred costs.

2.1.2.4 Identify Output Measures

During previous three steps of stage-one cost allocation, all effort has been paid for translating the existing structure and cost data into the newly created activity model. At this stage-two cost allocation, the activity output measures will be identifying, the calculation of the activity unit cost will be performing, then the assigning of cost to jobs or products.

Each activity may have many outputs but only one output will be identified as the primary activity output. However, it needs to examine the components of the activity and sees how these information will be used as a source of improvement in the evaluation analysis.

Usually, while converting inputs to outputs, activities always consume resources. On the other hand from the organisation view, outputs consume activities during their creation. Therefore, the matter at this point is how to measure the consumption of the activities that go into the outputs by considering two points:

- How much of the cost of an activity is used for a unit of output?
- How much time, actual and elapsed does it take for one unit of output?

Since these output-activity relationships drive the cost of the activity during the creation of the output, they are also known as output drivers. Output measures illustrate cost and time relationships of the individual activity and its output. Using these measures allows the cost and time requirements of output to be calculated and evaluated on an individual and comparative scale.

2.1.2.5 Developing Output Measures

Within a single activity model of any design, there will be a multitude of different types of output measures in order to form some sort of procedural control to ensure consistency and utility. Therefore, the determination of an activity output measure is an iterative process that must be repeated for each individual activity within the model. A standard approach is required to guarantee the compatibility of the process in order to ensure consistency from activity to activity.

2.2 Activity Modeling

IDEF or Integrated definition methods are a structured approach to enterprise modeling and analysis. They are used to perform modeling activities in support of enterprise integration.

The original IDEF methods were developed for the purpose of enhancing communication among people who needed to decide how their existing systems were to be integrated which was the result of the U.S. Airforce Program for Integrated Computer Aided Manufacturing (ICAM). The aim of the ICAM program was to increase manufacturing productivity through the systematic application of computer technology.

The IDEF methodology concerns with six variants of theirs defined for specific purpose as following:

- IDEF0-Function Modeling Method. It is designed to allow the description of a system's functions through the process of function decomposition and categorisation of the relations between functions.
- IDEF1-Information Modeling Method. It is designed to allow the description of the information that an organisation deems important to manage to accomplish its objectives.
- IDEF3-Process Flow & Object State Description Capture Method. It is developed to support the structuring of descriptions of the user view of the system.
- IDEF5-Ontology Description Capture Method. It is developed to serve as a method for fact collection and knowledge acquisition.
- IDEF1X-Data Modeling Design Method. It is developed to assist in the design of semantic data model.
- IDEF4-Object-Oriented Design Method. It is developed to address the need for a design method to assist in the production of quality designs for object-oriented implementations.

2.2.1 IDEF0

IDEF0 is one of the most widely known techniques for functional modeling as a top-down hierarchical method, which provides a description of functions and processes in manufacturing.

IDEF0 models are comprised of three distinct sections those are diagrams, text and glossary that all interrelated with each other. Each diagram depicts activities in the pictorial form, which is the most important element of any IDEF0 model. The codes that are used for graphical representation are consists of input, control, output and mechanism or ICOM. For each diagram, it can not only be decomposed indefinitely depending on the level of detail intended, but also designed supporting text to explain information presented in the diagram. Then, the glossary section is provided to ensure that the terminology used is meaningful across all of the functional and organisational boundaries. A typical diagram of IDEF0 is illustrated in Figure 2-2 below.

Since IDEF0 is a top-down flow hierarchical model, so it is a very appropriate technique for displaying a complicate system that provides a comprehensive description of the functions, information and objects which are associated with a manufacturing system.

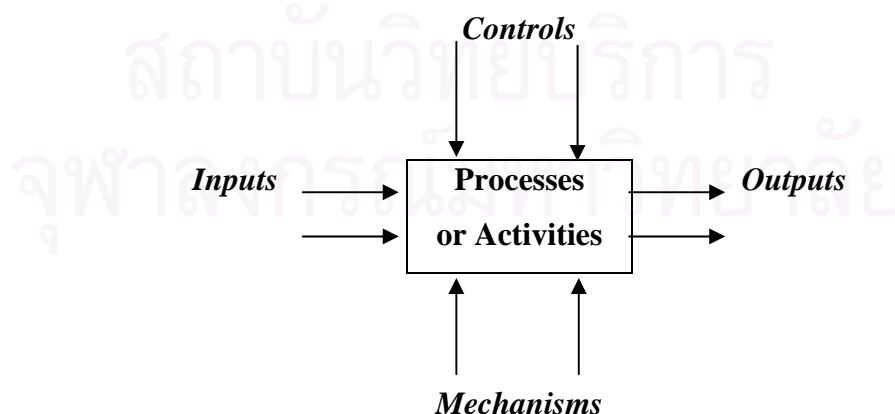

Figure 2-2: A typical IDEF0 Model.

2.2.1.1 IDEF0 model

According to Figure 2-2 above, ICOM (Inputs, Controls Outputs and Mechanisms) are objects or data requires performing an activity as explained below:

- **Inputs** are objects or data that are transformed by the activity and represents by an arrow enter the box from the left-hand side.
- **Controls** activate an activity or modify an activity behavior and represents by an arrow that enters to the box from the topside. All activities must have at least one control arrow but may not necessarily have an input arrow.
- **Outputs** are objects and data resulting from an activity or process and represents by an arrow leaving the right-hand side of the box.
- **Mechanism**, by which an activity is performed and represented by an arrow entering at the bottom of a box.

2.2.2 Determining Activity Costs Using IDEF0

There are five major steps as discussed in section 2.1.2 (ABC Methodology) that must be performed as a part of ABC generally by the costing team or a small group of people working full time on the program which can take anywhere between a few days to a few weeks. Nevertheless, there are five steps for determining activity cost by using IDEF0 that represents in the node tree diagram as shown below.

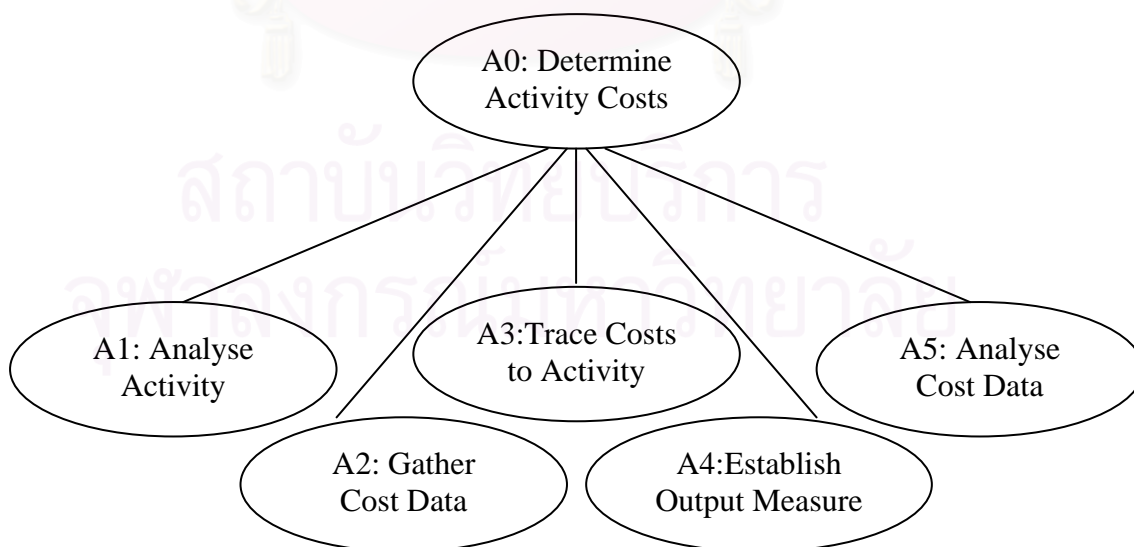

Figure 2-3: A node tree diagram of determining activity costs (Source: Department of Defense of U.S., 1993)

2.2.3 Refining IDEF0 Activities

An IDEF0 activity is in a refined state for using in ABC analysis when:

- It action on at least one input or one initiating or activating control.
- It expends the resources, or factors or production that furnished by at least one input or one mechanism.
- It generates at lease one output therefore when an activity produces more than one output, only one output must be declared as primary activity output with all others being byproducts.
- The selection of the primary activity output, it will be the output whose variability is the most directly rational to the variability of its resources or production.
- The primary activity output can be measure and each unit of output has the same intensity for any given period of time, which each unit incurred by its cost pool on the same amount of cost and proportion to cost elements.

2.3 Literature Survey

The following texts, journal, and case study are reviewed in order to make more clearly understood the various topics and several interesting points in associated with this thesis.

- Brimson, James A., (1991), “Activity Accounting: An Activity-Based Costing Approach”, John Wiley & Sons: USA.

In this book, the author identifies a number of benefits to be derived from activity accounting. Most important among these are:

1. Improving make/buy, estimating, and pricing decisions that are based on a product cost that reflect the manufacturing process.
2. Providing and guiding to eliminate waste by identifying of non-value added activities.
3. Planning and control are conducted at the process level.

4. Improving the effectiveness of budgeting by identifying the relationship between cost and performance at the different service levels.
 5. Providing insight into the dynamic change and difficulty in determining element of cost i.e. overhead.
- Commonwealth Department of Employment, Final report, (2000), “A Study to Develop a Costing Methodology for the Australian Higher Education Sector”, <http://www.detya.gov.au/highered/otherpub/costing/html>.

This final report on May 2000 is aimed to provide detailed guide on how an ABC project may be performed in a university environment. It covers the costing methodology utilised by three trial case studies in implementing ABC for the Higher Education Sector as a strategic tool. It also provides the details outcome extracts from the reports prepared for each trial study. The following are the interesting points of the study:

1. Providing extensive information concerning activities, its definition, and cost drivers;
2. Identifying of the key people and contact details involved in the study at the three universities;
3. Introducing detailed of software that used in the study such as EasyABCPlus and Prodacaop.
4. Covering the standard templates that used in the study including an example of the key project management documents such as project chart.

However, the most critical issue is the development of conceptual framework model during the early stages of the costing project in designing of ‘cost flow architecture’. This is where the structure of the system is created to meet the system objective by providing the right kind of information at the right level of detail.

- <http://www.rutgers.edu/Accounting/raw/ima/imabc.htm>. This web provides an overview of the process of designing and implementing an ABC system. Whether the organisation is large or small, a manufacturer or a service business, the outlined principals can be used to develop a cost-effective ABC system consistent with the organisation's needs. The guideline assumes that the reader is already familiar with basic ABC concepts.
- Nujarin Chimploy (1999), "ABC for Operating Budget of Electricity Generating Authority of Thailand Case Study: Mae Moh Power Plant, Lampang" (in Thai). This thesis is interested in improving ABC for operating budget of EGAT by using the Mae Moh power plant as the case study. The following are the key findings from the study.
 1. Both primary and secondary activities in responsibility center can be determined by using job description and fieldwork study.
 2. There are 71 types of activity cost pools in Mae Moh Power Plant, but the total activities are 189 activities and its 95 responsibility centers.
 3. There are 59 cost drivers that caused cost to activities in the plant.
 4. Three types of forms are designed for budgeting and explained how to use it, i.e. Activity Based Budgeting Form, Percentage of Activity Form and Requisition Form.
 5. Two types of measurements are identified i.e. financial and non-financial measurement.
- Robin Cooper, Robert S.Kaplan, (1991) "The design of cost management systems: text, cases, and readings", Prentice-Hall: USA. This text furnishes the understanding of ABC terminology and principals, research methodology. It also highlights various types of case studies from companies that have implemented an ABC. These including the implementation issues that lead management to implement ABC, process and resources needed, results and insights gained, and action plan.

- Paramate Suwanpradit, (2000), “ Activity-Based Costing of Project Management in the Construction of a 2,000 m³ LPG Spherical Tank Project”, Chulalongkorn University and University of Warwick.

The following are the main points from the study.

1. This thesis is aimed to apply ABC technique to evaluate and analyse the cost of project management in the construction of a 2,000 m³ LPG Spherical Tank Project.
 2. By using the IDEF0 technique to develop activities model, the major activities and their sub-activities are then be identified.
 3. The cost of each activity was defined by allocating the direct and overhead cost of the organisation into their organisational elements of the project team and then assigned into each activity that had been listed by activity model.
 4. The output measures are established to analyse the activity output and performance i.e., the cost per unit of output and the time consumed. Then both of activity cost and output measures are used to evaluate for cost reduction and process improvement.
 5. By applying the ABC model as a tool for cost simulation, the total cost of the project management is expected to be decreased by 30% and the total time of the case project is expected to be shorten by 8 months from the original needed of 31 months.
- Supakit Chantaravisutilert, (1999), “Comparative Study of Activity-Based Costing and Conventional Costing for Job Order for Manufacturing of a Plastics Injection Mold”, Chulalongkorn University and University of Warwick.

The key learning points from this study are summarised as below.

1. Two objectives of this thesis are to study the cost structure of mold manufacturing by using ABC method in comparing with a conventional job order costing concept and to find out the most effective methodology of calculating the actual cost of a mold.
2. Two sample molds are applied and calculated by using both ABC and conventional method. The two methods are then compared in each of the cost

elements structure i.e., direct cost, overhead cost of the mold department, and overhead cost of support functions.

3. Although, the result of the study shown many advantages of ABC method over the traditional system in determining the cost of the mold. But, the ABC method was more complicated both in calculation and data acquisition. Therefore, the study proposed that the ABC method should be used when the cost accuracy of the molds was required, whereas the traditional should be applied when the maximum cost tolerance of 20% was accepted.
- Duangdee Angsamaporn, (1999), “Manufacturing Cost System Improvement in a Curtain Wall Factory by Activity-Based Costing System”, Chulalongkorn University. (in Thai).

The key findings from this study are summarised as below.

1. The objective is to improve the manufacturing cost system by using an ABC.
 2. The program developed by this work is a tool for gathering information associated with activity and developing a model to allocate resources to activities and then attributing to products to enable cost calculations and reporting by bill of material.
 3. The system provided an overview and analysis of all activities and help in identifying non-value added activities that can be removed in the short term to reduce costs.
 4. The study improved the manufacturing cost by means of accuracy, efficiency and readily identifying the source of costs.
 5. It argued that the type of factory, which is most suitable for ABC, is the factory that has many service departments with high service costs.
- Department of Defense of US (1993)” Corporate Information management (CIM) Improvement Methodology for DOD Function Managers”, <http://www.dtic.mil/c31/bprcd/3001.htm>

This web described the study of ABC project that aimed to set a fee at a competitive level of the Fort Sill Department of Public Works (DPW). The following are the basic approach applied by this project:

1. Obtain the activities performed and present them as a set of base line (AS-IS) IDEF0 models.
2. Determine the rational effort used and resources consumed by each of the primary activities. If the primary activity costs is less than 80% of the total expenditures, it will investigate secondary activities and attribute their costs in some consistent, traceable and reasonable way to the primary activities until at least 80% of the total expenditures are accounted for.
3. Compute business process cost as the sum of their non-overlapping element primary activity cost, then analyse these results for effectiveness and efficiency by comparing the measurement output produced by the business process to the cost that generating them.
4. Develop an alternative ways of generating the same or higher level of desirable outcomes at a lower unit cost by eliminating non-value added activities or simplifying the business processes. Then evaluating the recommended alternatives.

The results of this study show that the DPW can appraise the non-value and value added activities and then the non-value added activities could be eliminated without diminishing the quality, timeliness or mission effectiveness of the desirable outcomes. Therefore, it is an effective means not only to reduce unit cost, but also simplify and consolidate the value-added activities.

- Innes, J. and Mitchell, F.(Dec 1991: 28-30) “Management Accounting”, ABC: A Survey of CIMA Members.

According to this survey undertaken in September 1990, the ABC was seen its limitation of use as follow:

1. Cost drivers are difficult to identify, collect and verify.
2. ABC approach seems to be difficult because of its complexity.
3. ABC is rather difficult to apply into industry, which have used the traditional costing system for a long time.
4. It is likely theoretical rather than practical.

5. It cannot clearly explain cost variability and has some limitation for improving cost control.
 6. Some respondents are not certain about the ability of the ABC use of stock valuation and income measurement in financial statement. Such as the profit computed as gross profit and net margin, but some are not certain about income statement.
- Chadwick, Leslie. (1993).” Management Accounting” London: Routledge.

This text is provided very useful guides, overviews, principals and examples of both ABC and absorption costing system. However, the following are the key characteristics of the old system that can use to compare with the ABC system.

1. It can make use of budgeted figures.
2. Separation of costs: Costs is separated into those which can be traced to the cost centre and those which cannot be traced that have to be shared out by using some arbitrary basis.
3. Product costs: Both of Variable and Fixed costs are included, but some of the fixed costs may be written off direct to the profit and loss account. For instance, the administration, selling and research cost.
4. Stock Valuation: Both of Variable and Fixed costs are included, but all or most of the fixed costs is carried forward to the next accounting period.
5. Recovery of Cost: It attempts to make sure that all costs are covered, but likely to be under- or over-recovery of overheads because absorption rates have to be predetermine.
6. Subjective Judgement: The exercise of subjective judgement is necessary, *re* the selection of absorption rated, choosing a method of apportionment and dealing with service department costs, etc.
7. Profit: Computed as a gross profit and net profit.
8. Reporting: It is advocated for external reporting by SSAP9. However, the full used of ABC for inventory valuation does not allow by SSAP9 as argued by Atkinson and et al (1995).
9. Decision Making: Absorption costing system is unsuitable for decision making since the cost never really be described as accurate.

- Dilley, S.C. et al, (March 1997: 34-37), “The Tax benefits of ABC: Companies with the right production and cost characteristics can achieve considerable savings”, Journal of Accountancy.

This journal discussed the two interesting points as below:

1. The principle of ABC is to focus on overhead costs. A company should understand its cost drivers and try to apply them to the products in proportion to the volume of activity that a product consumes.
 2. ABC can provide another potential benefit: a company can realise significant tax savings by using ABC to determine taxable income.
- Haldane, Glenn. (May 1998: 60-62), “Fixed Overheads: How should you allocate costs to products?”, Accountancy International Ed.

The following are the main concentration points discussed by the author:

1. Fixed costs have been more difficult to deal with, but the absorption costing approach has tried to spread them over the production and succeed in some reasonable way. However, it cannot provide relevant costs in covering for all purposes and some problems in practice. These are such as the over- or under-absorption of overheads, a highly risk tool for decision making, and a simple product with low price should not absorbed the same overhead as a complex one, which produced in the same factory.
2. From the reason that the resources are consumed by activities then activities are consumed by the products. Therefore the use of ABC can not only potentially trace all relevant costs to the products, but also avoids facing with any over- or under-recovery of overheads that as a result the product cost will be more accurate.
3. Since the implementation of ABC seems to be more costly than the absorption costing system, therefore a company should analyse cost-benefit of ABC application.

Chapter 3

Activity-Based Cost Estimation System

3.1 Introduction

In this chapter, the Activity-Based Cost allocation system will be applied to estimate the mechanical installation cost in the Simple Cycle Power Plant Construction Project (SCPPCP). This methodology consists of the following main steps:

- Activity Analysis;
- Cost Analysis and Information Gathering;
- Developing Cost Flow Model;
- Gather Resource Driver Information; and
- Activity-Based Cost Allocation.

3.2 Activity Analysis

The activity analysis is the first important step in the Activity Based Costing. To develop the activity model, the scope of the activity model must be clearly defined. In this study, the Work Breakdown Structure (WBS) and IDEF0 activity modeling technique were used as tools to develop the activity model. Activity model developing will consider the priority of work captured in IDEF0 models and their associated definitions. The composition of each macro activity should then be verified by the consensus agreement among cross-functional managers associated with the installation process of SCPPCP.

3.2.1 Work Breakdown Structure

After the top management had approved the investment plan, the details of action plan that describes the feasible characteristic of the project should be developed. In this study, the case project is the Engineering and Procurement (EP) Contract Agreement that signed between EGAT as an owner and its contractor. This means that the contractor will take all responsibility on the engineering and procurement works of the project, while the construction work are fall under the responsibility of EGAT. Since then, the construction project was established and assigned to use the

in-house manpower to perform all of the construction and commissioning works. In order to achieve the project performance, budget, and schedule requirements. The entire project must be well coordinated and tightly controlled by developing a project work phases, which consists of five main phases as suggested by Meredith and Mantel (1995:467) as below;

- Phase I: Project definition is to scope out the work in each of key work phases. This includes constructing a ‘Summary WBS’ for the project, laying out the major project milestones, and getting an estimate of the general magnitude of the project in terms of total labour-hours required.
- Phase II: Work package definition, this involves determining exactly what must be done, when, who will do it, and how much it will cost. One example of work package definition would be a ‘Detailing WBS’ for the project, which should be prepared to determine the exact nature of the tasks required to complete the project.
- Phase III: Base-line input data, this phase includes such items as estimates of activity duration, budgets, labour requirements, constraints, and the other items.
- Phase IV: Status monitoring, this is ongoing monitoring where input data on project status which are collected through system modules for schedules costs, cash flows, and so forth.
- Phase V: Output reports and analysis, this final phase is the definition of output management reports for the control function which consists of defining the data analyses that must be conducted and report formatting and generation. Example outputs would be earned value, cost status, variance and other such reports.

However in this study, only the ‘Detailing WBS’ of the case project is shown in Figure 3-1 in the next page.

3.2.2 IDEF0 Activity Modeling

Scope of the modeling

When identifying activities for the development of the new costing systems, the objectives of the study is the key factor that driving the level of detail. Moreover, as suggested by Commonwealth Department of Employment (2000), more detail is typically required when identifying activities for business process improvement than

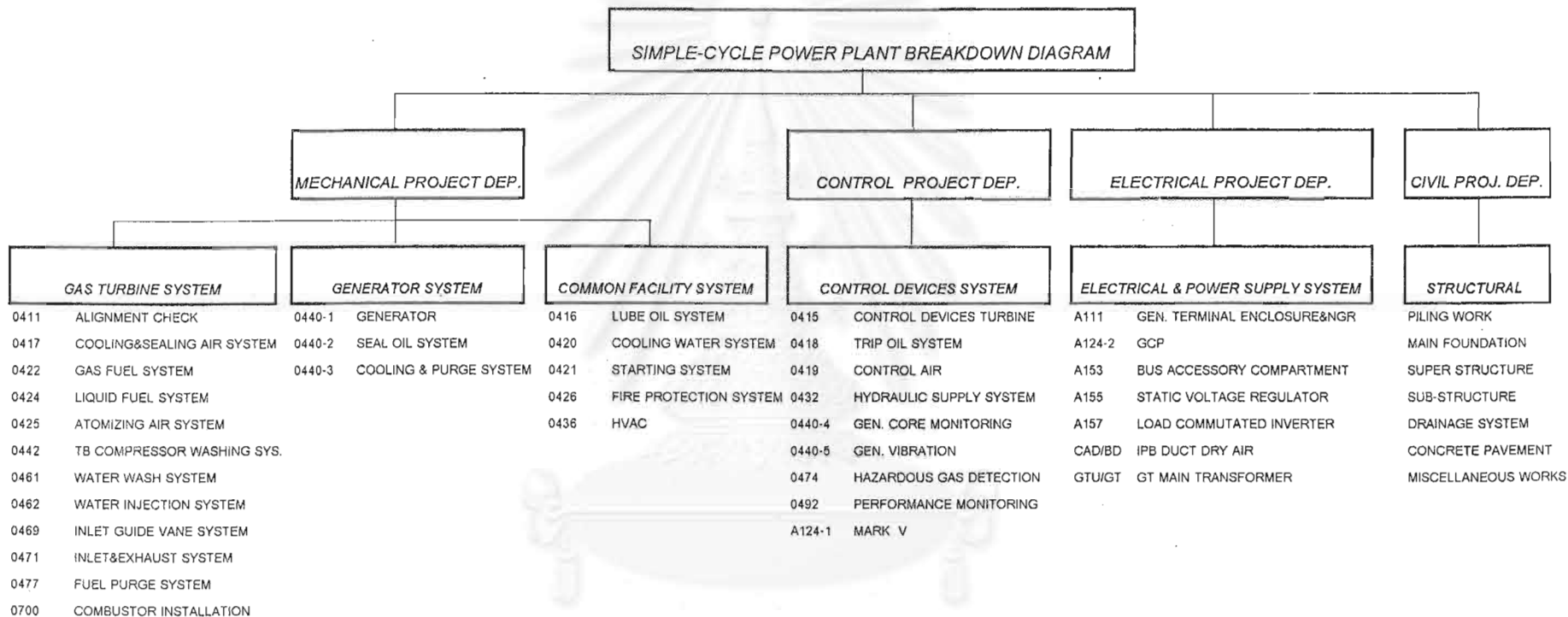

Figure 3-1: Project WBS for the Simple Cycle Power Plant Construction Project (SCPPCP).

that required for calculating the costs of products or other costing objectives. Thus, the following is the scope of the activity model in this study:

- The main objective of this study is required for estimating the costs of products or cost objects, rather than to improve the business process.
- The IDEF0 activity modeling would be constructed in the concept that the selected process will be decomposed into a set of macro activities that not too narrowly or too much in detail as a set of micro activities. Nevertheless, it should not be so rough that it is too difficult to be understood.
- Only the installation activities, which are performed by the operational elements of the organisation that should be focused and require further analysis. However, the Managerial and some of the Supporting activities that are performed by their managerial and supporting elements in the organisation are also defined in the process of this activity model.

3.2.2.1 IDEF0 of the Installation Process

The IDEF0 activity model of the mechanical installation process of a Simple Cycle Power Plant Construction Project (SCPPCP) is analysed and decomposed into the next level of context diagram. These consist of the 7 major activities (A1 to A7) and their 32 sub activities as summarised in Table 3-1 below. The detail analysis and decomposition of IDEF0 activities model of the case project, are illustrated in logical order in the following Figure 3-2 to 3-9.

For instance, in Figure 3-2, the A-0 node is the overview of the mechanical installation activity for the SCPPCP that comprised of 7 major activities. Those are A1 (Advance Planning), A2 (Equipment Receiving), A3 (Foundation Preparation), A4 (Lifting On-Base), A5 (System Piping), A6 (System Cleaning) and A7 (Painting, Insulating and Labelling).

After that all of each 7 major activities should then be decomposed into its next level of context diagram in logical order until it reaches the last activity of the processes.

As shown in Figure 3-3, for example, the major activity A1 (Advance Planning) can be further decomposed into their 7 sub activities i.e. A11 (WBS Constructing), A12 (Milestones Laying-Out), A13 (Determining Proj. Organisation), A14 (Establishing Control Network), A15 (Specifying Baseline Input Data), A16 (Project Monitoring)

and A17 (Evaluating Performance). This is the same methodology as for major activity A2 to A7 (Figure 3-4 to 3-9) those are decomposed into their sub activities.

Node	ACTIVITY	Node	SUB-ACTIVITY
A-0	Mechanical Installation Works	A0	A1 to A7
A1	Advance Planning and Detailed Scope of Work	A11	1.Constructing Work breakdown Structure
		A12	2.Laying Out Project Milestones
		A13	3.Determining Project Organisation
		A14	4.Constructing Project Control Network
		A15	5.Specifying Base Line Input Data
		A16	6.Monitoring Project Status
		A17	7.Evaluating Project Performance
A2	Receiving, Handling and Storing	A21	1.Verifying Receipt of Equipment and Materials
		A22	2.Unloading and Warehousing
		A23	3.On-Site Transporting
		A24	4. Unpackaging and Preparing for On-base
A3	Foundation Preparation	A31	1.Verifying Interface and Terminal Points
		A32	2.Installing Foundation Embedments and Supports
		A33	3.Setting and Grouting Foundation or Sub-Sole Plates
A4	Lifting, Assembling, Setting, Aligning and Fixing	A41	1.Lifting and Hauling Equipment On-Base
		A42	2.Setting and Levelling
		A43	3.Parts Inserting and Assembling
		A44	4.Aligning and Coupling
		A45	5.Key Finishing and Fixing
A5	Piping, Interconnecting and Welding	A51	1.Installing Supports and Hangers
		A52	2.Fitting-Up and Centering
		A53	3.Welding, Gasketing&Bolting, or Sealing
		A54	4.Non-Destructive Testing
		A55	5.Leak, Pressure or Hydrostatic Testing
A6	System Cleaning, Blowing-Down, and Flushing	A61	1.Installing Flush Pipes/Hoses, Strainers, and Filters
		A62	2.Initial Filling and Lubricating
		A63	3.Blowing-Down or Flushing
		A64	4.Final Restoring
A7	Painting, Insulating, and Labelling	A71	1.Surface Preparing
		A72	2.Preventive Coating
		A73	3.Insulating and Lagging
		A74	4.System Labelling and Tagging

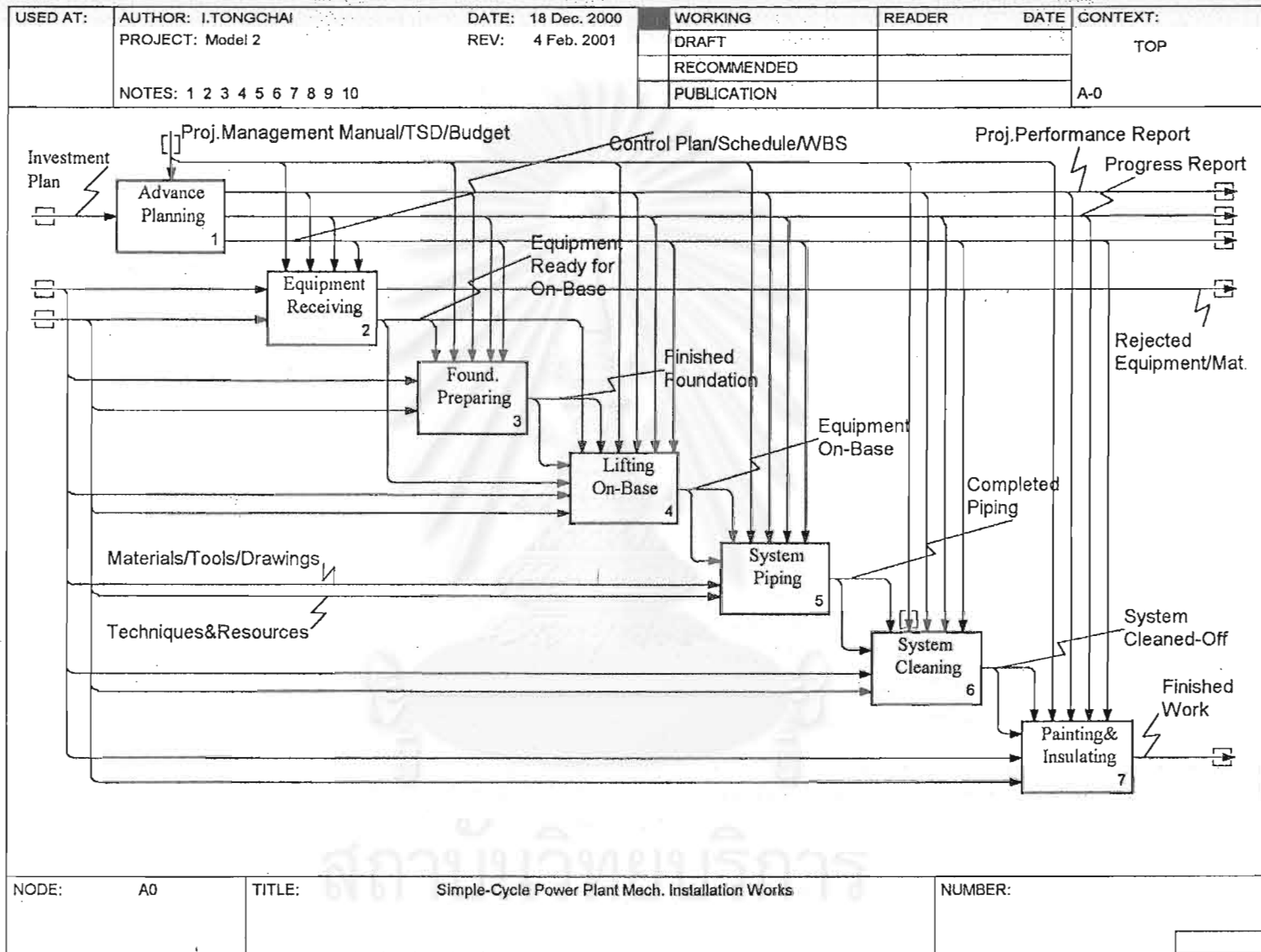

Figure 3-2: The AO Node for the mechanical installation activities of the Simple Cycle Power Plant Construction Project.

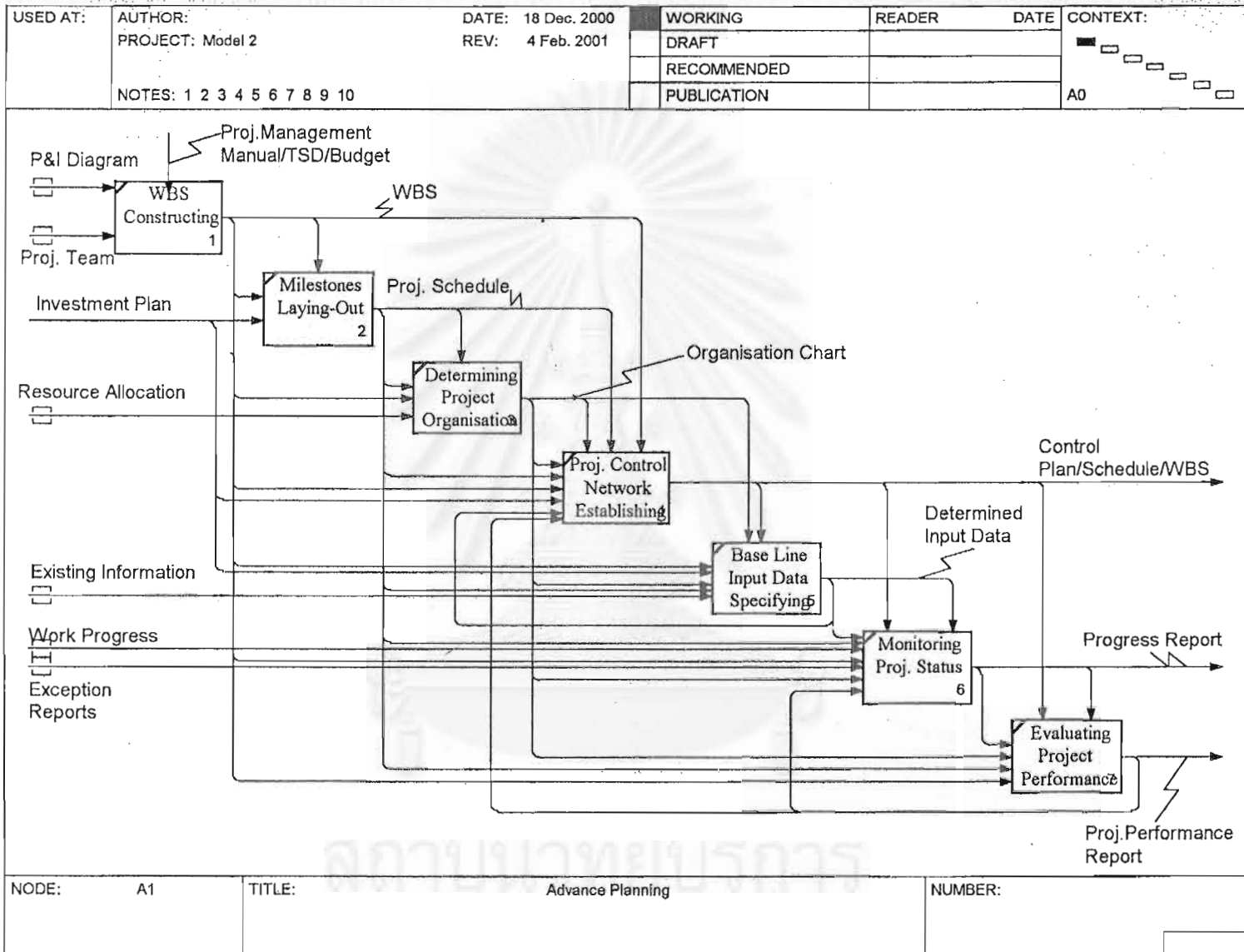

Figure 3-3: The A1 Node for the Advance Planning activities of the Simple Cycle Power Plant mechanical installation work.

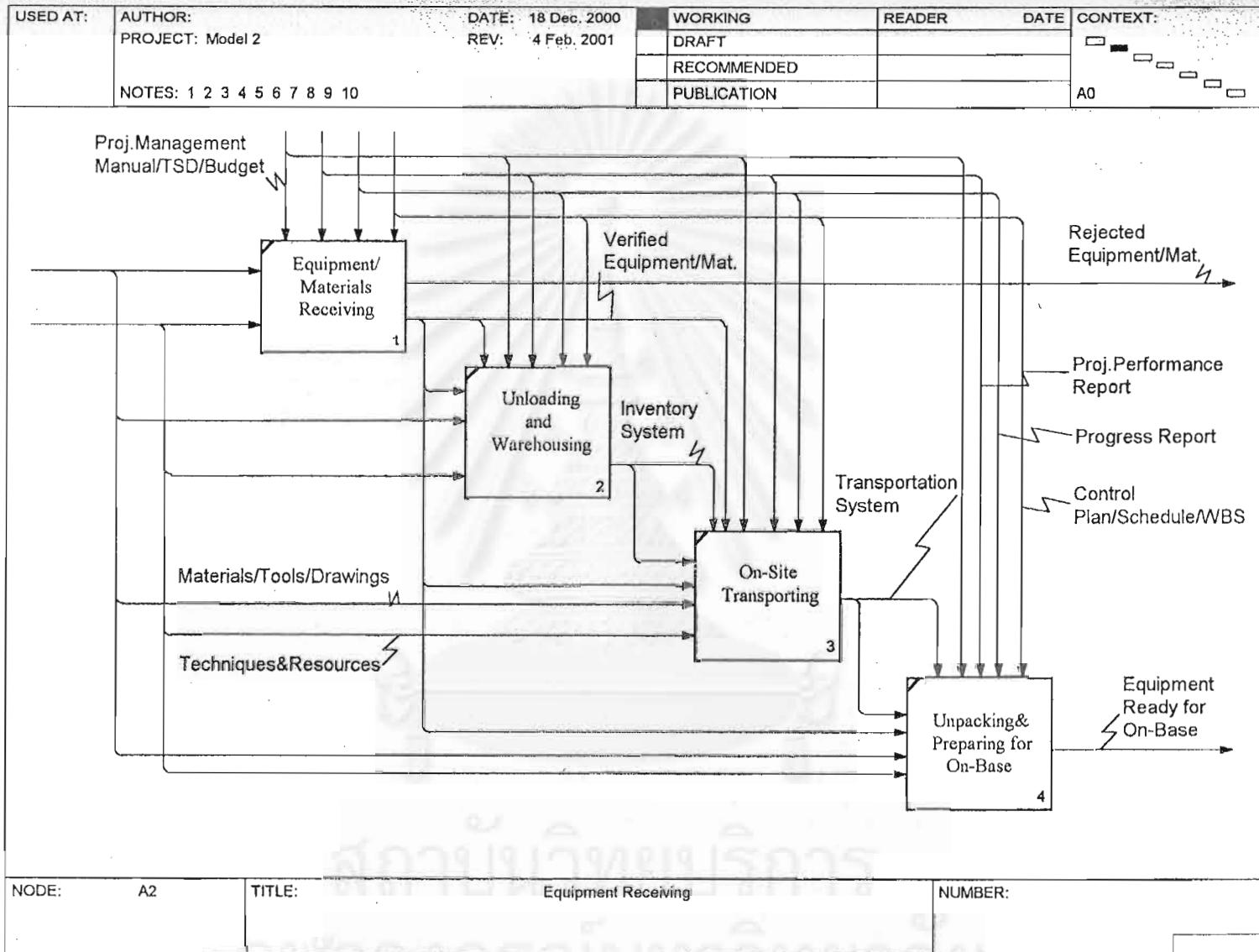

Figure 3-4: The A2 Node for the Equipment Receiving activities of the Simple Cycle Power Plant mechanical installation work.

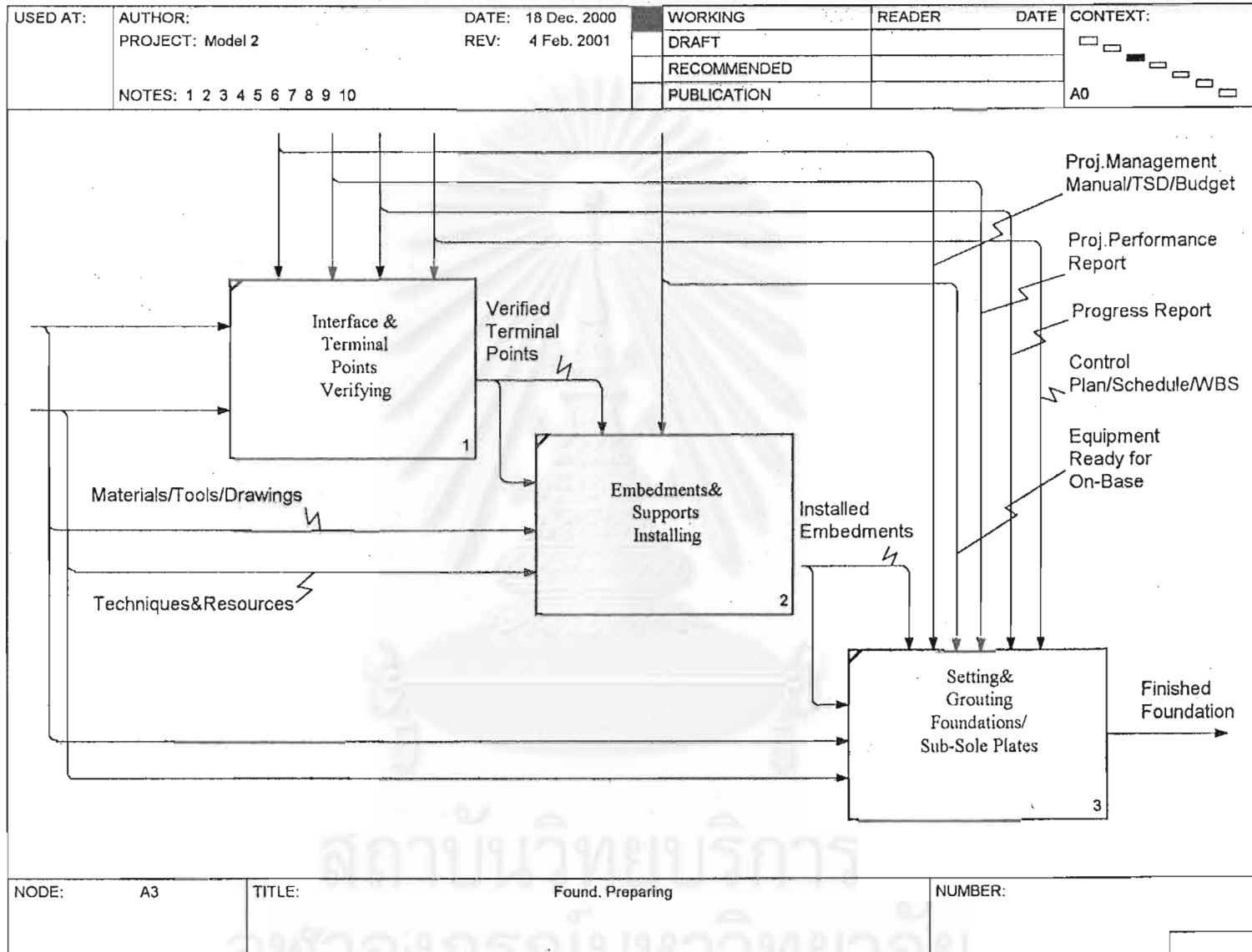

Figure 3-5: The A3 Node for the Foundation Preparing activities of the Simple Cycle Power Plant mechanical installation work.

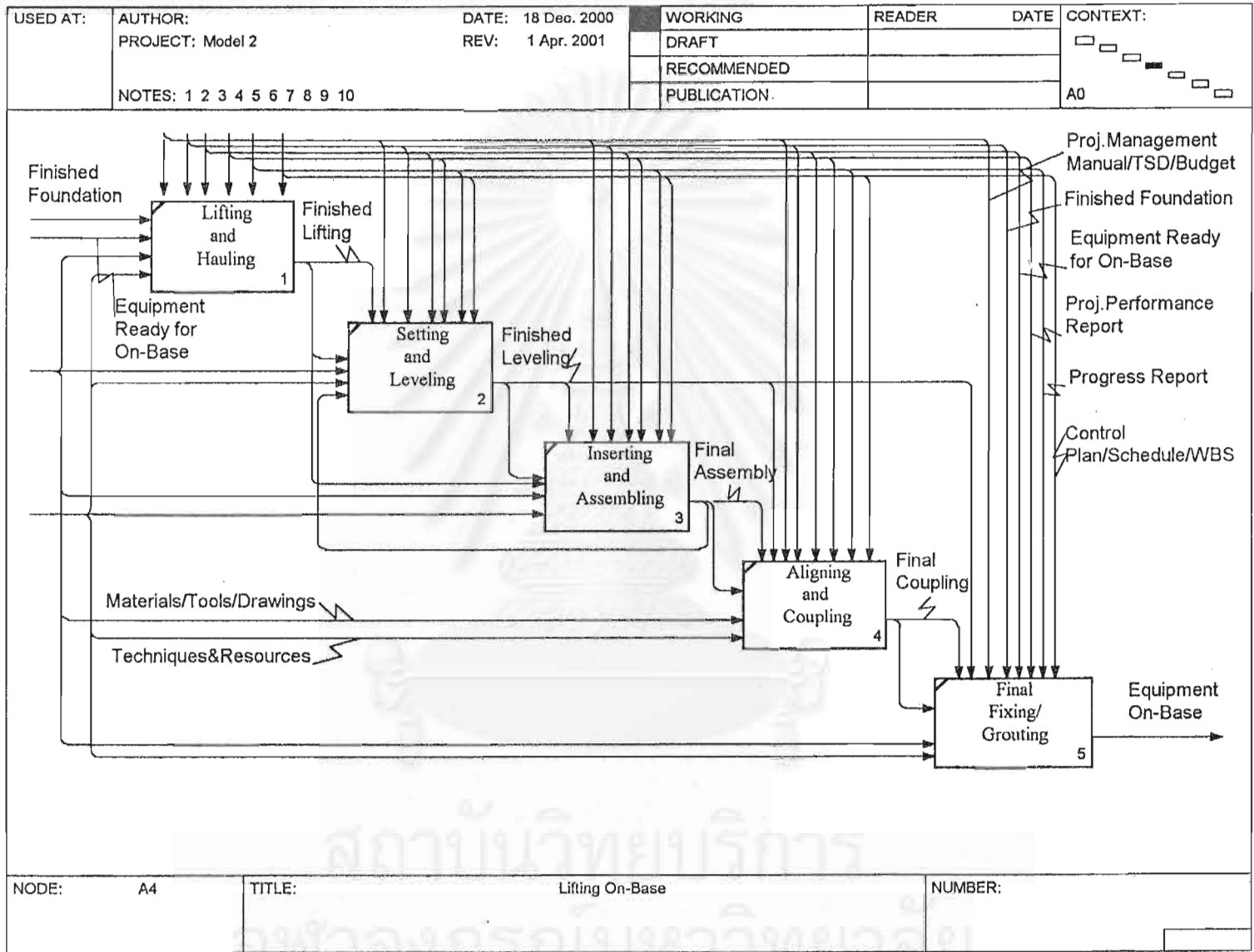

Figure 3-6: The A4 Node for the Lifting On-Base activities of the Simple Cycle Power Plant mechanical installation work.

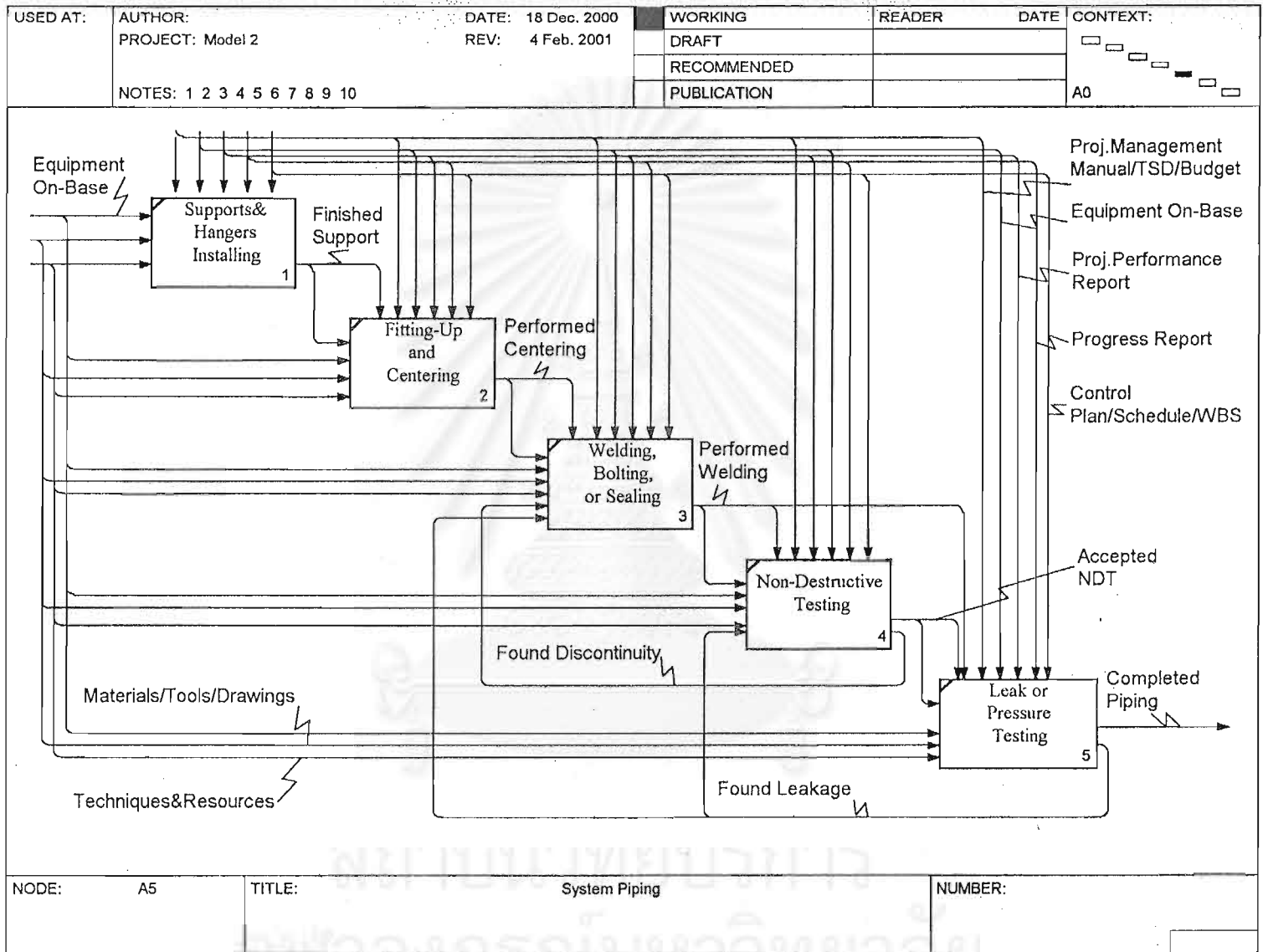

Figure 3-7: The A5 Node for the System Piping activities of the Simple Cycle Power Plant mechanical installation work.

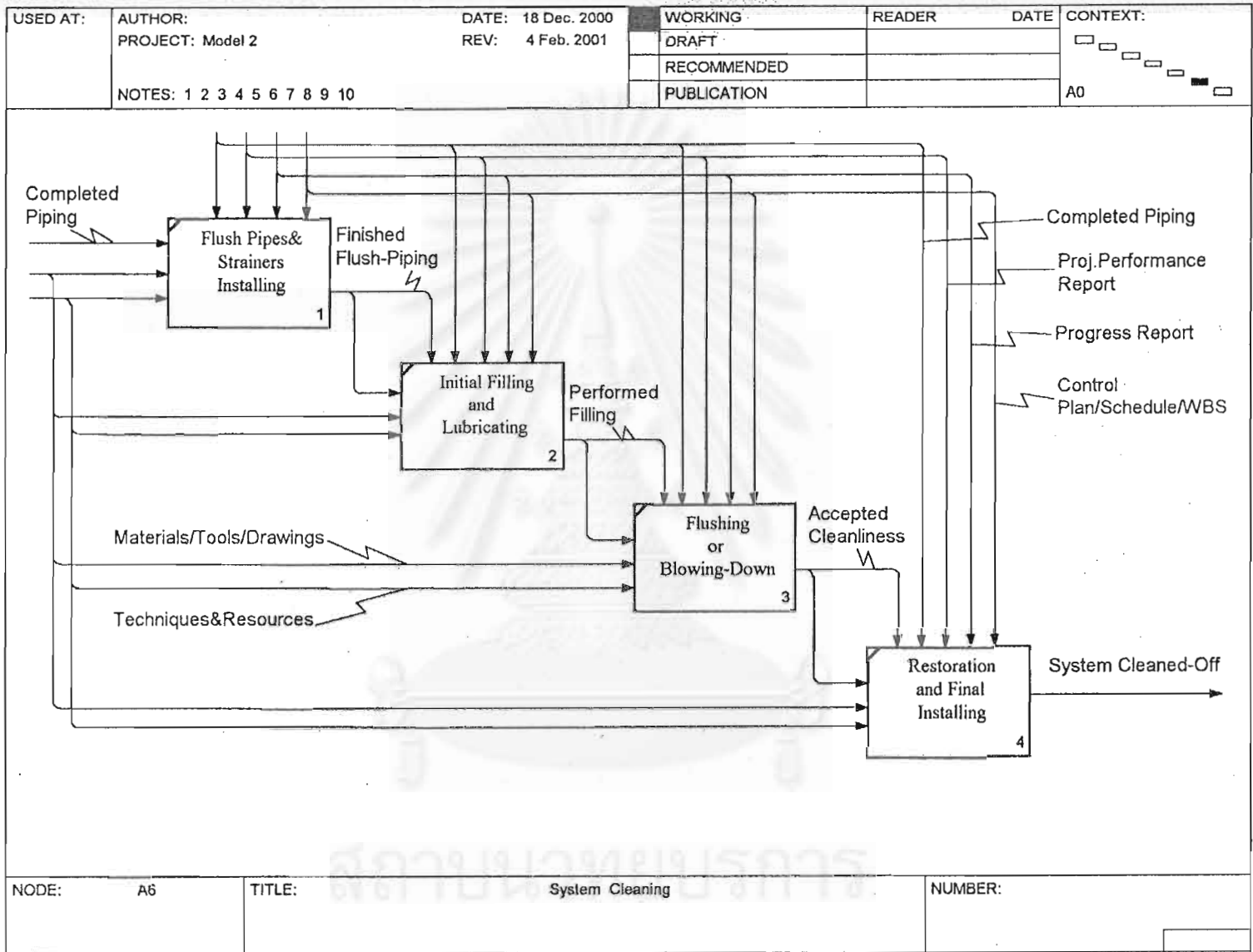

Figure 3-8: The A6 Node for the System Cleaning activities of the Simple Cycle Power Plant mechanical installation work.

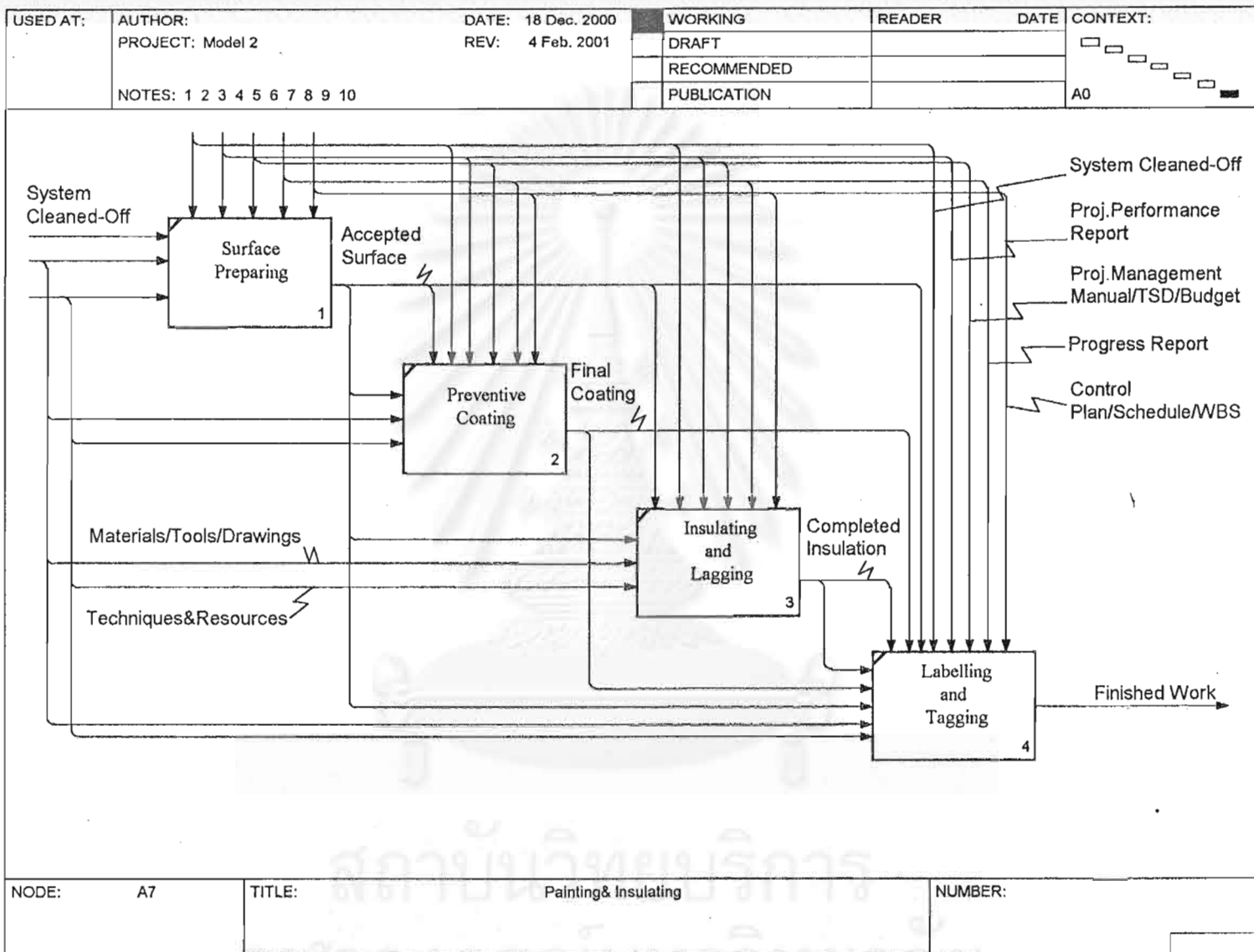

Figure 3-9: The A7 Node for the Painting and Insulating activities of the Simple Cycle Power Plant mechanical installation work.

3.3 Cost Analysis

Having performed activity analysis, the cost analysis is the second stage of the costing process that is very important. In order to reduce the time of the study, this stage can be performed simultaneously with the activity analysis step. Cost analysis can be performed through various steps, those are cost data scope out, identifies overhead costs, and gathers cost information.

At first step, historical costs were typically used as the baseline activity cost. The various type of accounting report can be provided the data of cost such as salaries of manpower, rental equipment cost, supplies cost, etc. However, when such a cost that do not summarize in detail ledgers or unavailable, the cost assignment equations or calculation should be used. Then, they were traced to the functional element of the case project in the second step.

3.3.1 Scope of Cost Data

The scope of cost data required relates to the scope of the activity model or process under study. In this study, the activity model under review is the process of the mechanical installation work of the Simple Cycle Power Plant Construction Project (SCPPCP) that perform by the assigned project team. It only one in many projects under responsible of the Mechanical Project Department (MPD) as discussed and shown in Figure 3-11 in section 3.4.1. The construction cost is the fixed cost that use for the installation work, which was set in budgetary accounting. However, it is not the real cost of the installation work of the project in some case. For example, the total manpower cost of the Chief of MPD in the project team is not fully charged to the installation cost. Moreover, some common expense is the share cost of all project under responsible of the MPD. Therefore, to gather the cost in this study, all the related cost should be captured as much as possible. Besides this, in some case, the calculation method is then required in order to synthesise the correct cost of this study.

3.3.2 Identify Organisational Cost Structure

In this study, the cost data and information are captured from the several of sources. Those are the accounting records of MPD, the General Administration Department the Human Resource Department and the Transportation and Handling Department, which are the major sources of the cost data. Moreover, the organisational cost structure was captured and classified into many categories. The details capturing of cost structure and its criterion are illustrated in Table 3-2 on the next page. However, they are identified and summarised into 6 main elements of costs as below.

- Manpower
- Supplies
- Rental Equipment
- Rental Heavy Equipment
- Facilities
- Miscellaneous Expenses

3.3.3 Cost Information Gathering

Having identified all relevance overhead costs of the case project, the following are the detail information about how to gather cost in each element of the cost structure respectively.

3.3.3.1 Manpower

The manpower cost is the most important expense of the organisation. From the theoretical point of view, it will account for 60 to 80 percent of the organisation cost. So, in this study, the cost estimate should be as accurate as possible. The manpower cost of the case project is comprised of seven elements as follows:

- **Salaries:** According to the organisation's policy, the actual salary or monthly wages of each employee that work for the case organisation is confidential. However, in order to gather the cost of salaries to the personnel within this project team, the midpoint salary of each level of those personnel would be captured instead of the actual one. Moreover, it will be useful and easier to use this midpoint salary to estimate the manpower cost for the future project of the

Table 3-2: The Identification of organisational cost structure, its details and criterion of the case project.

(Source: Ratchaburi Power Plant Construction Project, EGAT)

Cost Element	Breakdown Item	Criteria	Abbreviation	Overall Cost (Baht/Month)
MANPOWER	Midpoint Salary	Next Table	MS.	
	Site Allowance	Next Table	SA.	
	Electricity Allowance	(14% of Salary)	EA	
	Providence Fund	(10% of Salary)	PF.	
	Skill Premium	(Engineer=3,200Baht/Month)	SE	
		(Welder Level 1-5 = 40, 45, 50, 65, 80 Baht/Day)	SW	
		(Crane Operator Level 1-5 = 0,6, 9, 12, 15 Baht/Hr.)	SC	
	Over Time	(Level 1-3: Max.= 120 Hr., Level 4-6: Max.=90Hr., Level 7~9: Max.=60Hr.)	OT.	
	Fringe Benefits	(=3%of (MS+SA+EA+PF+SE+SW+SC+OT))	FB.	
SUPPLIES	Office Supplies	Paper, files, printer ink, stationery, and other office equipment	SPL.	฿85,000
	Consumable Materials	Erection Tools, consumables, temporary materials		฿840,000
RENTAL EQUIPMENT	Rental Cars (Excluding fuel oil)	(Sedan = 19,200 Baht/Month)	RE	฿19,200
		(Pick-Up 1= 13,900 Baht/Month)		฿13,900
		(Pick-Up 2= 7,450 Baht/Month)		฿7,450
		(Van= 20,000 Baht/Month)		฿20,000
	Computer & Ass.	2,000 Baht/Month	RC	฿2,000
	Copy machine	3,600 Baht/Month	RC	฿3,600
RENTAL HEAVY EQUIPMENT	Truck Tractor with Hydraulic Trailer =350 Tons	Rental Cost = 62.600 Baht/Day	RE	
(Including Fuel Oil and	Truck Tractor with Trailer =50 Tons	13,165 Baht/Day		
Operating Cost)	Truck Tractor with Trailer =25 Tons	6,200 Baht/Day		
	Gantry Crane=100Tons	54,160 Baht/Day		
	Mobile Crane=15Tons	9,030 Baht/Day		

Table 3-2: The Identification of organisational cost structure, its details and criterion of the case project.

(Source: Ratchaburi Power Plant Construction Project. EGAT)

Cost Element	Breakdown Item	Criteria	Abbreviation	Overall Cost (Baht/Month)
	Mobile Crane=40Tons	22,370 Baht/Day		
	Mobile Crane=80Tons	48,150 Baht/Day		
	Truck Crane=3 Tons: 6 Wheels	2,750 Baht/Day)		
	Truck Crane=5 Tons: 10 Wheels	4,970 Baht/Day		
	Fork Lift Truck=5 Tons	5,100 Baht/Day		
	Fork Lift Truck= 10 Tons	6,150 Baht/Day		
	Truck 6 Wheels	2,520 Baht/Day		
	Truck 10 Wheels	3,430 Baht/Day		
FACILITIES	Site Office	Straight-Line Depreciation (Useful life= 5 Years, Usage= 10%, 240d)	SOD.	฿1,250,000
	Work Shop	Straight-Line Depreciation (Useful life= 5 Years, Usage= 15%, 160d)	WSD	฿750,000
	OVHC:Overhead Head Crane#1	Straight-Line Depreciation (Useful life = 30 Years,usage35%, 240d)	HED.	฿179,335,000
	OVHC:Overhead Head Crane#2	Straight-Line Depreciation (Useful life = 30 Years, Usage 35%, 2 d)	HED.	฿179,335,000
MISCELLANEOUS EXPENSE	Fuel Oil Supply (Max. =150~200 L/Month)	Sedan Car (Max. =150 L/Month, @17 Baht/L)	FOS.	฿2,550
		Pick-Up Car (Max. = 200 L/Month, @15 Baht/L)		฿3,000
		Van Car (Max. =250 L/Month, @15 Baht/L)		฿3,750
	Water Supply Expenses	10.70 Baht/Unit , Including 7%VAT:(overall=200m ³ /d)	WS.	฿47,080
	Electricity Supply Expenses	Site Office= 30,000 Baht/Month(Average)	ES1	฿30,000
		Work Shop=14,000 Baht/Month (Average)	ES2	฿14,000
		Site Work= 2,000,000 Baht/Month(Average)	ES3	฿2,000,000
	Telephone Fee	30,000 Baht/Month	TF.	฿30,000
	Security	2,645,800 Baht /Year	SEC.	฿220,483
	Facility Sustaining	686,400 Baht /Year	FAC.	฿57,200

case organisation. Therefore, the following Table 3-3 is the salary table data reprinted from Human Resource Department, which lists the midpoint salary, site allowances and maximum overtime of each level of employee in the case project. There are two types of employee in the case project i.e., the permanent employee and the contract employee. The contract employee is the personnel that the case project hiring to work for the project within a limited duration or period.

- **Allowance:** The Allowance cost has two components. First is the ‘Site Allowance’ cost as identified and classified by each level of employee as also depicted in the Table 3-3 below. This cost is the cost that the case organisation pays only to its permanent employee who works outside their based office. It means that the payment will not pay to its contract employee or its permanent employee who works at their based office. Second is the ‘Electricity Allowance’ cost that pays to the entire permanent employee in monthly basis. According to the Human Resource Department, the ‘Electricity Allowance’ cost is approximately 14 percent of salary in each level of each employee.
- **Providence Fund:** The providence fund of the personnel of the project team can be gathered from the data of the Human Resource Department. It is approximately 10 percent of salary in each level of each employee as shown in Table 3-2 above.
- **Over Time:** According to the project management policy, the over time cost is limited by the maximum working hours in each level of employee within a month. In this case the maximum working hours of over time and its cost by each level is classified in Table 3-3 below.
- **Skill Premium:** The skill premium is comprised of three fields of skill employee who concerns in the installation work, i.e. Engineer, Welder, and Crane Operator. According to the organisation’s policy about the skill premium, the standard rate for an engineer is 3,200 Baht per head per month. The standard rates for the welder and crane operator are classified by its skill level from level 1 to level 5 as identified in Table 3-4 in the next two pages.

Table 3-3: The midpoint salary, site allowance and maximum over time for each of employee.

Source: Human Resource Department, RPPCP, EGAT.

Level	Midpoint Salary (Baht/Month)		Site Allowance (Baht/Month)	Over Time (Max.)	
	Employee	Contract Employee	Employee	Hour/Month	Baht/Month
15	฿196,350	N/A	฿40,500	N/A	N/A
14	฿157,750	N/A	฿33,000	N/A	N/A
13	฿125,650	N/A	฿30,000	N/A	N/A
12	฿103,700	N/A	฿24,000	N/A	N/A
11	฿62,500	N/A	฿21,600	N/A	N/A
10	฿53,800	N/A	฿21,600	N/A	N/A
9	฿47,050	N/A	฿19,200	60	฿13,443
8	฿41,500	N/A	฿19,200	60	฿11,857
7	฿36,500	N/A	฿19,200	60	฿10,429
6	฿31,650	N/A	฿17,100	90	฿13,564
5	฿27,400	N/A	฿17,100	90	฿11,743
4	฿22,050	N/A	฿17,100	90	฿9,450
3	฿17,550	฿14,861	฿15,000	120	฿10,029
2	฿14,450	฿12,232	฿15,000	120	฿8,257
1	฿10,100	฿6,479	฿15,000	120	฿5,771

Table 3-4: The standard rates of welder and crane operator skill premium.
Source: Human Resource Department, RPPCP, EGAT.

Skill Level	Welder Premium		Crane Operator Premium	
	Baht/Day	Baht/Month	Baht/hr	Baht/Month
1	40	1,200	0	0
2	45	1,350	6	1,260
3	50	1,500	9	1,890
4	65	1,950	12	2,520
5	80	2,400	15	3,150

- **Fringe Benefits:** The fringe benefits of the personnel of the case organisation are such as hospital fee, bus, and etc. The cost of fringe benefits can be gathered from the accounting data of the Mechanical Project Department (MPD) that is approximately 3 percent of the summation of salary, allowances, providence fund, skill premium, and over time.

Since there are totally 66 persons who were assigned to work for this project, those are including Chief of MPD; Section Head, Mechanical Engineers; Clerk; Secretary; Foreman's; Chief Technicians; Technicians; Chief of Crane Operator; Crane Operators; Truck Driver; Welders and Contract Labours. Therefore, the total costs for each of individual manpower of the MPD who worked for this project is shown in Table 3-5 as following.

3.3.3.2 Supplies

The supply cost of SCPPCP can be captured from the accounting data of the MPD as shown in Table 3-2. The supplies cost are comprised of two key elements. The first one is the site supplies cost, which pays for the consumable materials, temporary materials, erection tools, and other site equipment that are identified by the accounting records to supplies. The site supplies cost of the MPD is approximately 840,000 Baht per month. The other one is the office supplies cost, which are such as paper, files, printer ink, office stationery, and other office equipment that are identified by accounting system to supplies. The office supplies cost of the MPD is approximately 85,000 Baht per month. Therefore, the total supplies cost of the MPD is approximately 925,000 Baht per month.

Table 3-5: The total of individual manpower cost of the employee of the simple-cycle power plant mechanical installation work.

ID No.	Position	Level	Midpoint Salary	Site Allowance	Electricity Allo	Providend Fund	Skill Premium	Over Time	Fringe Benefit	Total Manpower Cost
			(MS)	(SA)	(EA)	(PF)	(SE/SW/SC)	(OT)	(FB)	(Baht/Month)
001	Div. Head	10	฿53,800	฿21,600	฿7,532	฿5,380	฿3,200	n/a	฿2,745	฿94,257
002	Section Head	8	฿41,500	฿19,200	฿5,810	฿4,150	฿3,200	฿11,857	฿2,572	฿88,289
003	Mech. Engineer	6	฿31,650	฿17,100	฿4,431	฿3,165	฿3,200	฿13,564	฿2,193	฿75,304
004	Mech. Engineer	6	฿31,650	฿17,100	฿4,431	฿3,165	฿3,200	฿13,564	฿2,193	฿75,304
005	Clerk	4	฿22,050	฿17,100	฿3,087	฿2,205	n/a	฿9,450	฿1,617	฿55,509
006	Secretary	3	฿14,861	฿15,000	฿2,081	฿1,486	n/a	฿6,369	฿1,194	฿40,991
007	Foreman	5	฿27,400	฿17,100	฿3,836	฿2,740	n/a	฿11,743	฿1,885	฿64,703
008	Foreman	5	฿27,400	฿17,100	฿3,836	฿2,740	n/a	฿11,743	฿1,885	฿64,703
009	Foreman	5	฿27,400	฿17,100	฿3,836	฿2,740	n/a	฿11,743	฿1,885	฿64,703
010	Foreman	5	฿27,400	฿17,100	฿3,836	฿2,740	n/a	฿11,743	฿1,885	฿64,703
011	Chief Technician	5	฿27,400	฿17,100	฿3,836	฿2,740	n/a	฿11,743	฿1,885	฿64,703
012	Chief Technician	5	฿27,400	฿17,100	฿3,836	฿2,740	n/a	฿11,743	฿1,885	฿64,703
013	Chief Technician	5	฿27,400	฿17,100	฿3,836	฿2,740	n/a	฿11,743	฿1,885	฿64,703
014	Chief Technician	5	฿27,400	฿17,100	฿3,836	฿2,740	n/a	฿11,743	฿1,885	฿64,703
015	Chief Technician	5	฿27,400	฿17,100	฿3,836	฿2,740	n/a	฿11,743	฿1,885	฿64,703
016	Technician	4	฿22,050	฿17,100	฿3,087	฿2,205	n/a	฿9,450	฿1,617	฿55,509
017	Technician	4	฿22,050	฿17,100	฿3,087	฿2,205	n/a	฿9,450	฿1,617	฿55,509

Table 3-5: The total of individual manpower cost of the employee of the simple-cycle power plant mechanical installation work.

ID No.	Position	Level	Midpoint Salary	Site Allowance	Electricity Allo	Providend Fund	Skill Premium	Over Time	Fringe Benefit	Total Manpower Cost
			(MS)	(SA)	(EA)	(PF)	(SE/SW/SC)	(OT)	(FB)	(Baht/Month)
018	Technician	4	฿22,050	฿17,100	฿3,087	฿2,205	n/a	฿9,450	฿1,617	฿55,509
019	Technician	4	฿22,050	฿17,100	฿3,087	฿2,205	n/a	฿9,450	฿1,617	฿55,509
020	Technician	4	฿22,050	฿17,100	฿3,087	฿2,205	n/a	฿9,450	฿1,617	฿55,509
021	Technician	4	฿22,050	฿17,100	฿3,087	฿2,205	n/a	฿9,450	฿1,617	฿55,509
022	Technician	4	฿22,050	฿17,100	฿3,087	฿2,205	n/a	฿9,450	฿1,617	฿55,509
023	Technician	4	฿22,050	฿17,100	฿3,087	฿2,205	n/a	฿9,450	฿1,617	฿55,509
024	Technician	4	฿22,050	฿17,100	฿3,087	฿2,205	n/a	฿9,450	฿1,617	฿55,509
025	Technician	4	฿22,050	฿17,100	฿3,087	฿2,205	n/a	฿9,450	฿1,617	฿55,509
026	Technician	3	฿17,550	฿15,000	฿2,457	฿1,755	n/a	฿7,521	฿1,329	฿45,612
027	Technician	3	฿17,550	฿15,000	฿2,457	฿1,755	n/a	฿7,521	฿1,329	฿45,612
028	Technician	3	฿17,550	฿15,000	฿2,457	฿1,755	n/a	฿7,521	฿1,329	฿45,612
029	Technician	3	฿17,550	฿15,000	฿2,457	฿1,755	n/a	฿7,521	฿1,329	฿45,612
030	Technician	3	฿17,550	฿15,000	฿2,457	฿1,755	n/a	฿7,521	฿1,329	฿45,612
031	Chief Operator	4	฿22,050	฿17,100	฿3,087	฿2,205	฿2,520	฿9,450	฿1,692	฿58,104
032	Crane Operator	3	฿17,550	฿15,000	฿2,457	฿1,755	฿1,890	฿7,521	฿1,385	฿47,559
033	Crane Operator	3	฿17,550	฿15,000	฿2,457	฿1,755	฿1,890	฿7,521	฿1,385	฿47,559
034	Crane Operator	3	฿17,550	฿15,000	฿2,457	฿1,755	฿1,890	฿7,521	฿1,385	฿47,559

Table 3-5: The total of individual manpower cost of the employee of the simple-cycle power plant mechanical installation work.

ID No.	Position	Level	Midpoint Salary	Site Allowance	Electricity Allo	Providend Fund	Skill Premium	Over Time	Fringe Benefit	Total Manpower Cost
			(MS)	(SA)	(EA)	(PF)	(SE/SW/SC)	(OT)	(FB)	(Baht/Month)
035	Crane Operator	2	฿14,450	฿15,000	฿2,023	฿1,445	฿1,260	฿6,193	฿1,211	฿41,582
036	Crane Operator	2	฿14,450	฿15,000	฿2,023	฿1,445	฿1,260	฿6,193	฿1,211	฿41,582
037	Truck Driver	2	฿14,450	฿15,000	฿2,023	฿1,445	฿1,260	฿6,193	฿1,211	฿41,582
038	Welder 5	2	฿12,232	n/a	n/a	฿1,223	฿2,400	฿8,340	฿726	฿24,921
039	Welder 5	2	฿12,232	n/a	n/a	฿1,223	฿2,400	฿8,340	฿726	฿24,921
040	Welder 5	2	฿12,232	n/a	n/a	฿1,223	฿2,400	฿8,340	฿726	฿24,921
041	Welder 5	2	฿12,232	n/a	n/a	฿1,223	฿2,400	฿8,340	฿726	฿24,921
042	Welder 2	2	฿12,232	n/a	n/a	฿1,223	฿1,350	฿8,340	฿694	฿23,840
043	Welder 2	2	฿12,232	n/a	n/a	฿1,223	฿1,350	฿8,340	฿694	฿23,840
044	Contract Labour	2	฿12,232	n/a	n/a	฿1,223	n/a	฿8,340	฿654	฿22,449
045	Contract Labour	2	฿12,232	n/a	n/a	฿1,223	n/a	฿8,340	฿654	฿22,449
046	Contract Labour	2	฿12,232	n/a	n/a	฿1,223	n/a	฿8,340	฿654	฿22,449
047	Contract Labour	2	฿12,232	n/a	n/a	฿1,223	n/a	฿8,340	฿654	฿22,449
048	Contract Labour	2	฿12,232	n/a	n/a	฿1,223	n/a	฿8,340	฿654	฿22,449
049	Contract Labour	2	฿12,232	n/a	n/a	฿1,223	n/a	฿8,340	฿654	฿22,449
050	Contract Labour	2	฿12,232	n/a	n/a	฿1,223	n/a	฿8,340	฿654	฿22,449
051	Contract Labour	2	฿12,232	n/a	n/a	฿1,223	n/a	฿8,340	฿654	฿22,449

Table 3-5: The total of individual manpower cost of the employee of the simple-cycle power plant mechanical installation work.

ID No.	Position	Level	Midpoint Salary	Site Allowance	Electricity Allo	Providend Fund	Skill Premium	Over Time	Fringe Benefit	Total Manpower Cost
			(MS)	(SA)	(EA)	(PF)	(SE/SW/SC)	(OT)	(FB)	(Baht/Month)
052	Contract Labour	2	฿12,232	n/a	n/a	฿1,223	n/a	฿8,340	฿654	฿22,449
053	Contract Labour	2	฿12,232	n/a	n/a	฿1,223	n/a	฿8,340	฿654	฿22,449
054	Contract Labour	1	฿6,479	n/a	n/a	฿648	n/a	฿4,418	฿346	฿11,891
055	Contract Labour	1	฿6,479	n/a	n/a	฿648	n/a	฿4,418	฿346	฿11,891
056	Contract Labour	1	฿6,479	n/a	n/a	฿648	n/a	฿4,418	฿346	฿11,891
057	Contract Labour	1	฿6,479	n/a	n/a	฿648	n/a	฿4,418	฿346	฿11,891
058	Contract Labour	1	฿6,479	n/a	n/a	฿648	n/a	฿4,418	฿346	฿11,891
059	Contract Labour	1	฿6,479	n/a	n/a	฿648	n/a	฿4,418	฿346	฿11,891
060	Contract Labour	1	฿6,479	n/a	n/a	฿648	n/a	฿4,418	฿346	฿11,891
061	Contract Labour	1	฿6,479	n/a	n/a	฿648	n/a	฿4,418	฿346	฿11,891
062	Contract Labour	1	฿6,479	n/a	n/a	฿648	n/a	฿4,418	฿346	฿11,891
063	Contract Labour	1	฿6,479	n/a	n/a	฿648	n/a	฿4,418	฿346	฿11,891
064	Contract Labour	1	฿6,479	n/a	n/a	฿648	n/a	฿4,418	฿346	฿11,891
065	Contract Labour	1	฿6,479	n/a	n/a	฿648	n/a	฿4,418	฿346	฿11,891
066	Contract Labour	1	฿6,479	n/a	n/a	฿648	n/a	฿4,418	฿346	฿11,891

3.3.3.3 Rental Equipment

The categories of the rental equipment used in this project are identified in Table 3-2 above and defined as following:

- **Cars:** There are four types of car rental rates that use in the installation works of SCPPCP. The car rental cost can be gathered from the data of the accounting records of MPD. First, the rental cost for the sedan car is 19,200 Baht per month. Second, the rental cost for the pick-up car (type 1) is 13,900 Baht per month. Third, the rental cost for the pick-up car (type 2) is 7,450 Baht per month. The last rental cost for the van car is 20,000 Baht per month. Therefore, the total car rental cost of the MPD is 60,550 (i.e. $19,200+13,900+7,450+20,000$) Baht per month.
- **Computer & Accessories:** The rental cost of computer and accessories can be gathered from the accounting data of MPD. So, the cost of the rental computer & accessories of the MPD is approximately 2,000 Baht per set per month.
- **Copy Machine:** The rental cost of copy machine of the case project depends upon the number of using (e.g copies). The rental cost of the MPD can be gathered from the accounting data of the General Administration Department. So, the rental cost of the copy machine of the MPD is approximately 43,200 Baht per year or 3,600 Baht per month.

3.3.3.4 Rental Heavy Equipment

Each rental rate of Heavy Equipment is captured from the Transportation and Handling Department. Thus, the rental costs of heavy equipment of the SCPPCP are the cost that incurred by 13 types of heavy equipment as also detailed in Table 3-2. These are including Truck Tractor with 350 Tons Hydraulic Trailer, Truck Tractor with 50 Tons Trailer, Truck Tractor with 25 Tons Trailer, 100 Tons Gantry Crane, 15 Tons Mobile Crane, 40 Tons Mobile Crane, 80 Tons Mobile Crane, 6 Wheels Truck with 3 Tons Crane, 10 Wheels Truck with 5 Tons Crane, 5 Tons Fork-Lift Crane, 10 Tons Fork-Lift Crane, 6 Wheels Truck and 10 Wheels Truck.

3.3.3.5 Facilities

The cost of facilities is usually included and distributed as depreciation, which represents the cost of using the facilities. In this study, the facilities cost is the summation of the depreciation cost gathering from the three sources of facilities that the MPD used, i.e. site office, workshop, and overhead cranes as shown in Table 3-2.

- **Site Office:** Since, the total value of the site office building that gathers from the Accounting Department is 1,250,000 Baht, then by using the straight-line depreciation method for over the estimated useful life of this temporary building i.e.5 year. This means that the residual values of the building after the 5th year is zero. So, the cost of using this office building is 20,833 Baht per month for the MPD. However, this project (SCPPCP) uses only the one-tenth area of MPD areas. Therefore, the cost of using the site office building that was charged to the SCPPCP is approximately 2,083 Baht per month.
- **Workshop:** This cost is calculated by using the straight-line depreciation method as the same as the site office facility cost. The workshop facilities are including such a workshop building, machine tools, welding machines, erection equipment, and other concerns facilities that identified by accounting system. Since, the total value of the workshop facility that gathers from the Accounting Department is 750,000 Baht then by using the straight-line depreciation method for over the estimated useful life of this temporary facility i.e.5 year. This means that the residual values of the building after the 5th year is zero. So, the cost of using this facility is 12,500 Baht per month for the MPD. However, this project (SCPPCP) uses only the 15% area of MPD areas. Therefore, the cost of using the workshop that was charged to the SCPPCP is approximately 1,875 Baht per month.
- **Overhead Crane:** Two overhead cranes are included in the facility cost from the reason that it is the permanent heavy equipment of the power plant, which are mainly used during the installation work. According to the accounting records, the value of each overhead crane is 179,335,000 Baht then by using the straight-line depreciation method for over the estimated useful life of this permanent

facility i.e.30 year. This means that the residual values of the overhead crane after the 30th year is zero. So, the cost of using each crane is 498,153 Baht per month for the MPD. However, from the Project Master Plan Layout this project (SCPPCP) was assigned to share the usage area approximately 35% of the total usage area that MPD used. Therefore, the cost of using each overhead crane that was charged to the SCPPCP is approximately 174,353 Baht per month.

3.3.3.6 Miscellaneous Expenses

According to the Table 3-2, the miscellaneous expenses cost of the case project is comprised of six elements as explained below:

- **Fuel Oil Supply:** The cost of fuel oil supply can be captured from the Project Management Policy, which limited the maximum fuel consumption rate per month in each type of car. The maximum fuel consumption rate for the sedan car, pick-up, and van are limited at 150, 200, and 250 Liters per month, respectively. By assuming that the fuel price for the benzene is 17 Baht per liter and for the diesel is 15 Baht per liter. Therefore, the fuel oil supply expense that incurred on the SCPPCP by the sedan car, pick-up, and van, which are limited at approximately 2,550, 3,000, and 3,750 Baht per month respectively.
- **Water supply:** The cost of water supply of the project was gathered from the accounting data of General Administration Department. This cost is approximately 47,080 Baht per month. By using a gathering form, the project consumes the water approximately 5% of the total consumption of the MPD. So the cost of utility water supply that was charged to this project, is approximately 2,354 Baht per month.
- **Electric Supply:** The expenses on the electric supply of the MPD were gathered from the accounting data of General Administration Department. There are three places that are account into this expense i.e. the site office, workshop, and site work area these costs are approximately 30,000, 14,000, and 2,000,000 Baht per month. By considering the Project Master Plan Layout, the SCPPCP uses each place approximately one-tenth floor out of a total area of the MPD. So, the

expenses of electric supply those were charged to the SCPPCP approximately 3,000, 1,400, and 200,000 Baht per month.

- **Telephone Fee:** Since, the expense on the telephone fee of the SCPPCP was gathered from the accounting data of the General Administration Department. Therefore, the telephone fee of this project is approximately 30,000 Baht per month.
- **Security:** The expense on the security of the entire area of the SCPPCP can be gathered from the accounting data of the General Administration Department. This total expense is approximately 2,645,800 Baht per year or 220,483 Baht per month. However, by considering the Project Master Plan Layout this project uses only one-tenth area of the entire area. So, the cost of security that was charged to the SCPPCP, is approximately 22,048 Baht per month.
- **Facility Sustaining:** The expense on the facility sustaining including such a cleaning work of all office, facility, site work, and etc. This expense can be gathered from the records of the General Administration Department. The total expense is approximately 686,400 Baht per year or 57,200 Baht per month. However, by considering the Project Master Plan Layout, this project uses only one-tenth area of the entire area. So, the cost of facility sustaining was charged to the project approximately 5,720 Baht per month.

3.4 Develop Cost Flow Model

This is a critical stage in the implementation process, where the structure of the estimation system is created. This conceptual model shows how overhead costs can be traced to activities and how activity costs will be then traced to cost objects.

As argued by Commonwealth Department of Employment of AUS (2000), the model should not only meet the system objectives at a minimum cost and complication, but also provide the right kind of information at the right level of detail. By using the information from the activity and cost analysis, an example of high level conceptual model is show below.

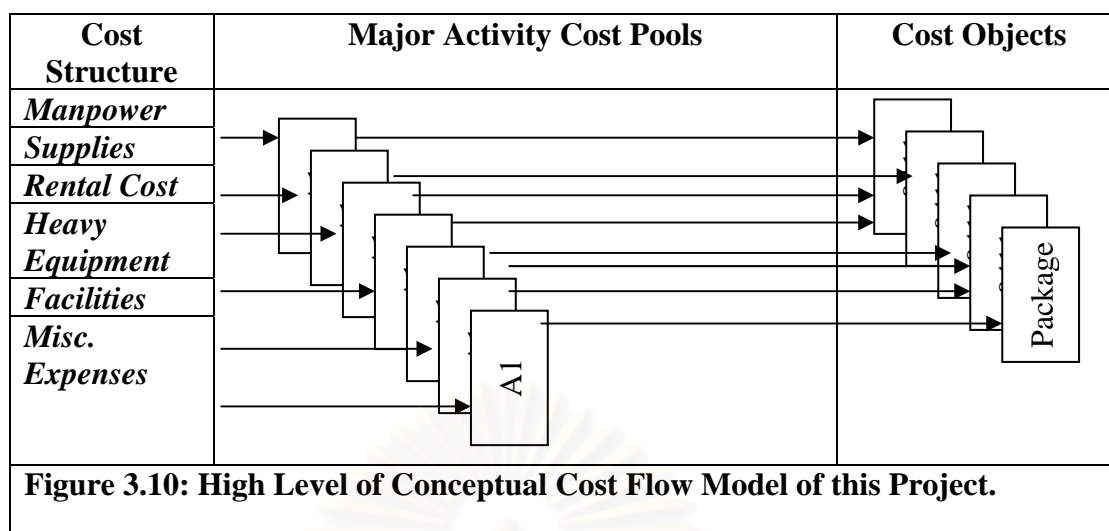

The above cost flow model is validated and verified by the discussion and brainstorming with the cross-functional managers who concerns with the project.

3.4.1 Perform Cost Objects Analysis

Having developed the bill of activity, gathered all the information of overhead costs and generated the Cost Flow Model. At this step, the cost objects of the project should then be identified priors to distribute all those costs into its.

In order to do that, the organisational structure should be divided into the smallest functional element that has a strategic means and help in decision making. For our case, during the study time, the MPD had many important projects and the other works under its responsibility as shown in Figure 3-11 below. Furthermore, the MPD had to assign or set a project team to operate each project and other works under its responsibility.

However, the organisation structure used in this study is not covering the entire organisational structure of MPD, but only the organisational structure of Simple-Cycle Power Plant that should then be considered in details. Thus, the project team organisational structure of the SCPPCP is depicted in Figure 3-12 on the next two pages.

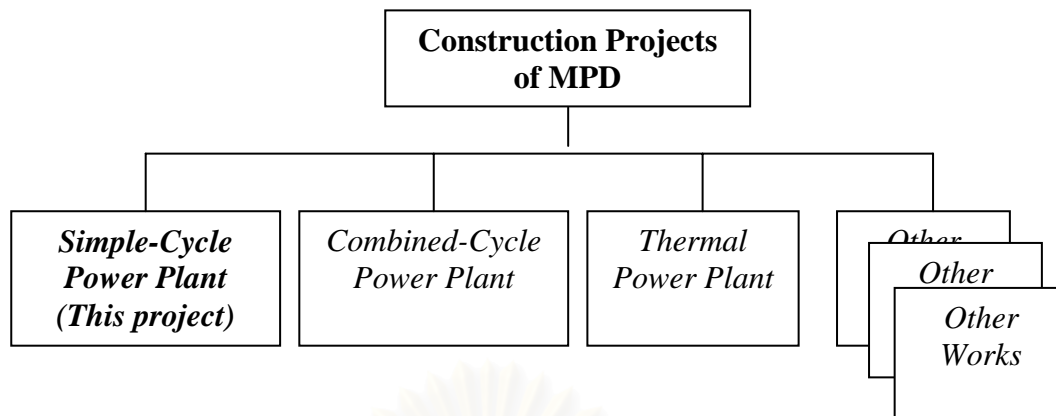

Figure 3-11: The organisational structure of the MPD (Source: RPPCP, EGAT).

According to Figure 3-12, the personnel of the MPD that are assigned into this project team organisation are totally sixty-six persons. Moreover, the organisational structure of this project team is divided into twenty-five functional elements, which consists of twenty operational elements, four supporting elements, and one managerial element as explained below.

- The first functional element is defined as managerial function or the Project Management (PPMC), which implied and automatically performed, by four key personals. Those are the Chief of Mechanical Project Department, which is the leader of this project team; the Head of the Mechanical Machine Project Section who takes fully responsibility on this project and directly reports to the MPD; and the two Mechanical Engineers who work directly under the section head.
- The operation functional elements are including 3 main systems i.e. Gas Turbine System, Generator System, and Common Facilities. Firstly, the Gas Turbine system that consists of twelve operational elements: alignment check, cooling sealing air, gas fuel, liquid fuel, atomizing air, GT compressor washing, water wash, water injection, inlet guide vane, inlet & exhaust, fuel purge, and combustor installation. Secondly, the Generator System that consists of three operational elements: generator, seal oil, and cooling & purge. Finally, the Common Facilities that consist of five operational elements: lube oil, cooling water, starting, fire protection, and HVAC.
- The supporting functional elements are including Workshop, Store Crane, Material Supply, and Administration.

SIMPLE-CYCLE POWER PLANT ORGANISATIONAL STRUCTURE

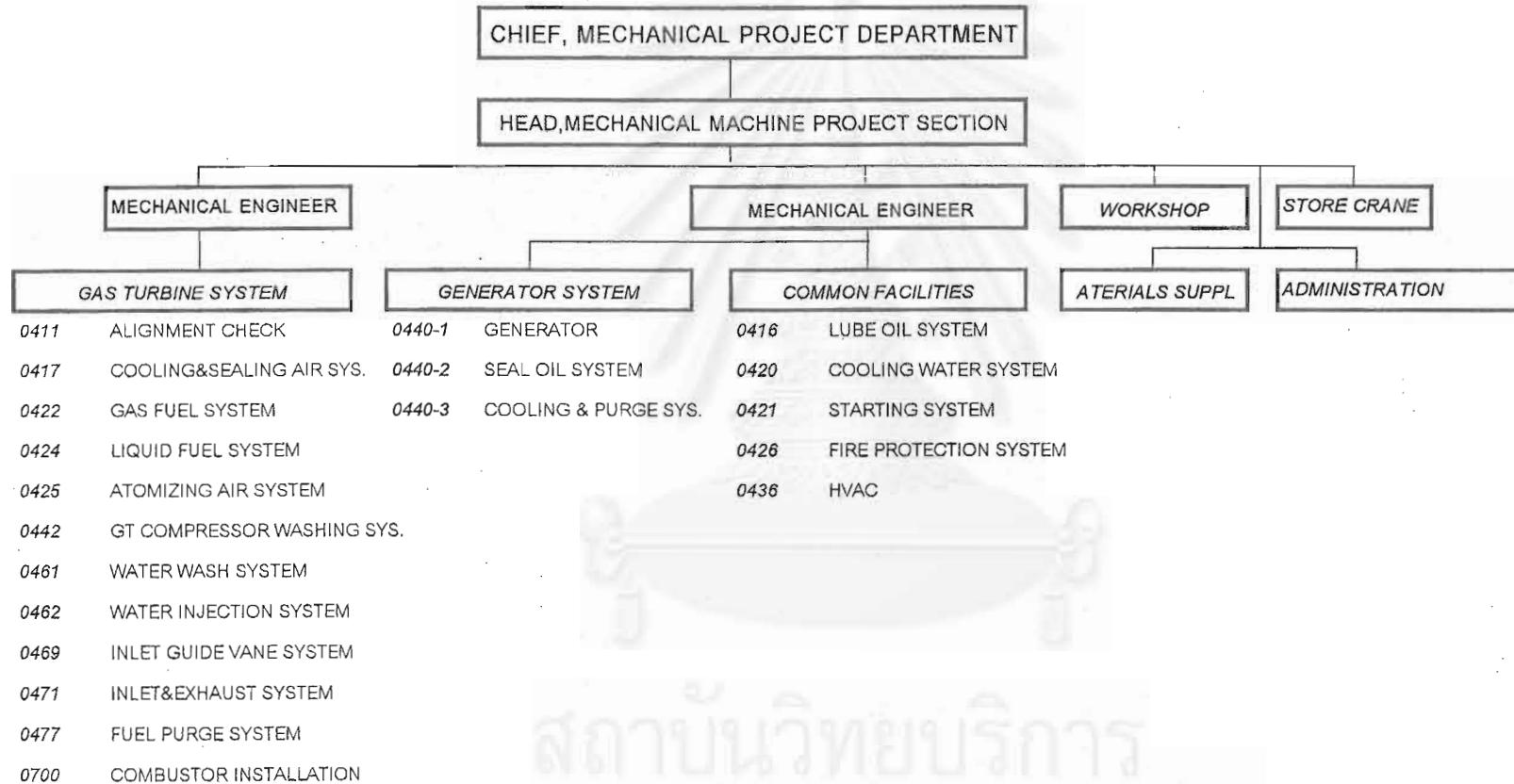

Figure 3-12: The project team organisational structure of the Simple Cycle Power Plant of MPD (Source: RPPCP, EGAT).

It can be seen so far that the organisational structure of this project, which totally includes twenty-five functional elements, is very useful for the further steps. Since, in order to distribute an organisational cost to its organisational structure, the cost objects of the project should be clearly identified. Moreover, this step concerns in confirming the cost objects in the scope of the costing project.

So, the technique used in this study to validate the cost objects is the extensive discussion and brainstorming with a cross-functional manager that associated with the construction project.

Consequently, it comes up with the results that the twenty operation elements of the organisational structure as discussed above are not only the most appropriate cost objects, but it also extensively uses in the private sector as the products or the services.

3.5 Gather Resource Driver Information

After identifying the cost objects and in order to attribute all overhead costs to the activities. The information of the resource driver on each functional element should be then collected. The following are the collection of information in each of cost structure and each of functional elements.

3.5.1 Manpower

From the reason that all of the personnel in this project are not assigned as the full-time manpower that worked in only one operational element. Besides that, they should worked for many operational elements that are under the responsibility of the MPD at the same time. Therefore, it needs to calculate the real manpower cost of the personnel that worked for this project.

As suggested by Commonwealth Department of Employment of AUS (2000), the factor that is used to calculate the actual manpower cost is the ratio of the effort time allocation of each personnel on each functional element of the project. This means that the manpower cost of each personnel will be divided by the ratio of the time that they work on each operational element of the project.

Furthermore, in order to make it easier to understand how to gather a resource driver information, the rational of time allocation diagram is illustrated in Figure 3-13 below.

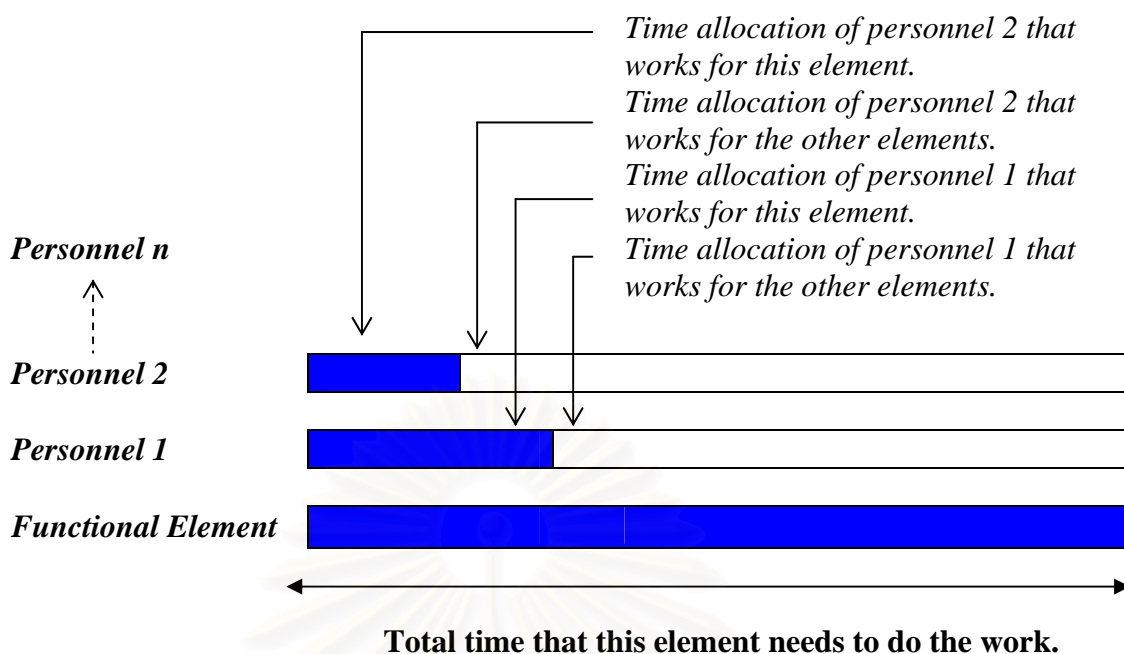

Figure 3-13: Time allocation of each personnel in each functional element.

Source: Reprinted from Paramate(2000:90)

Having understood the conceptual idea of the rational of effort time that allocate into the functional elements, it should then be appropriated to gather the information about the effort time allocation on each of functional element. By using the Gathering Form, the personnel that worked for this project was interviewed and asked to fill the form. Together with that, the percentage of the effort time allocation that each personnel spent on each functional element in related with the total time available, which was gathered by considering the Project Schedule. These is as shown in the following Table 3-6.

Furthermore, the Manpower cost of each functional element can be calculated by using the Equation (1) as below:

$$\text{Manpower Cost } j = \sum (\text{Manpower Cost } i \times \% \text{ of Time Allocation } i) \quad \dots(1)$$

While i = Identification no. of each personnel that works in that functional element.
 j = Identification no. of each functional element.

Table 3-6: The percentage of time allocation and cost distribution on each of cost object by each of employee within this project .

Personnel				Effort Time Allocation (%)																							
				Gas Turbine System										Generator Sys.			Common Facilities					Materials	Workshop	Crane	Admin.	Proj.Man.	
				0411	0417	0422	0424	0425	0442	0461	0462	0469	0471	0477	0700	0440-1	0440-2	0440-3	0416	0420	0421	0426	0436	M/S	W/S	OVHC	ADM.
001	Div. Head	10	\$94,257																							10	
002	Section Head	8	\$88,289	3	2	2	2	2	2	2	1	3	2	1	3	2	2	3	2	1	2	2	2	1	1	1	64
003	Mech. Engineer	6	\$75,304	7	5	5	5	5	6	5	5	2	7	5	2							5	2	2	1	33	
004	Mech. Engineer	6	\$75,304												7	5	5	10	5	5	5	5	7	2	2	1	44
005	Clerk	4	\$55,509																			5	5	5	80	5	
006	Secretary	3	\$40,991																			5	5	5	80	5	
007	Foreman	5	\$64,703	7	7	7	7	7	7	7	7	7	7	7								5	3	3		5	
008	Foreman	5	\$64,703												7	7	6	30	3	3	3	25	5	3	3	5	
009	Foreman	5	\$64,703																			95				5	
010	Foreman	5	\$64,703																				95			5	
011	Chief Technician	5	\$64,703	30		5	10	5	5	5	3	5	30		2												
012	Chief Technician	5	\$64,703		10	30	15	10	5	10	10				10												
013	Chief Technician	5	\$64,703													30	5	20	10	15	20						
014	Chief Technician	5	\$64,703													25	20	35	5		15						
015	Chief Technician	5	\$64,703																			100					
016	Technician	4	\$55,509																			100					
017	Technician	4	\$55,509																			100					
018	Technician	4	\$55,509	50		5	20	5	5	5	3	5			2												
019	Technician	4	\$55,509									100															
020	Technician	4	\$55,509		10	50				20	20																
021	Technician	4	\$55,509				50	20	15				15														
022	Technician	4	\$55,509												50	5		10	15	20							
023	Technician	4	\$55,509												25	5		10	15	20	25						

Table 3-6: The percentage of time allocation and cost distribution on each of cost object by each of employee within this project .

Personnel			Effort Time Allocation (%)																								
			Gas Turbine System										Generator Sys.			Common Facilities					Materials	Workshop	Crane	Admin.	Proj Man		
Employee ID/Position/Level/Cost			0411	0417	0422	0424	0425	0442	0461	0462	0469	0471	0477	0700	0440-1	0440-2	0440-3	0416	0420	0421	0426	0436	M/S	W/S	OVHC	ADM.	PPMC
047	Contract Labour	2 \$22,449									80				5		15										
048	Contract Labour	2 \$22,449												80	5		15										
049	Contract Labour	2 \$22,449													20	75	5										
050	Contract Labour	2 \$22,449								5					5		60					40					
051	Contract Labour	2 \$22,449																				100					
052	Contract Labour	2 \$22,449	60																10	10	10	10					
053	Contract Labour	2 \$22,449									60			40													
054	Contract Labour	1 \$11,891	37	3	3	3	3	3	3	3	3	3	3	3	3	3	6	3	3	3	3	3	3				
055	Contract Labour	1 \$11,891	3	37	3	3	3	3	3	3	3	3	3	3	3	3	6	3	3	3	3	3	3				
056	Contract Labour	1 \$11,891	3	3	3	37	3	3	3	3	3	3	3	3	3	3	6	3	3	3	3	3	3				
057	Contract Labour	1 \$11,891	3	3	3	3	3	3	3	3	37	3	3	3	3	3	6	3	3	3	3	3	3				
058	Contract Labour	1 \$11,891	3	3	3	3	3	3	3	3	3	3	3	37	3	3	6	3	3	3	3	3	3				
059	Contract Labour	1 \$11,891	3	3	3	3	3	3	3	3	3	3	3	3	3	37	6	3	3	3	3	3	3				
060	Contract Labour	1 \$11,891	3	3	3	3	3	3	3	3	3	3	3	3	3	3	37	3	3	3	3	3	3				
061	Contract Labour	1 \$11,891	3	3	3	3	3	3	3	3	3	3	3	3	3	3	6	3	3	3	3	37	3				
062	Contract Labour	1 \$11,891	3	3	3	3	3	3	3	3	3	3	3	3	3	3	6	3	3	3	3	3	37				
063	Contract Labour	1 \$11,891	3	3	3	3	3	3	3	3	3	3	3	3	3	3	6	3	3	3	3	3	3	37			
064	Contract Labour	1 \$11,891	37	3	3	3	3	3	3	3	3	3	3	3	3	3	6	3	3	3	3	3	3				
065	Contract Labour	1 \$11,891	3	3	3	3	3	3	3	3	3	3	3	3	3	3	37	3	3	3	3	3	3				
066	Contract Labour	1 \$11,891	3	3	3	3	3	3	3	3	3	3	3	3	3	3	6	3	3	3	3	37	3				
Total Cost Distribution(Bah/Month)			\$115,344	\$41,124	\$86,051	\$89,725	\$46,311	\$45,074	\$46,613	\$50,943	\$25,355	\$159,571	\$40,448	\$18,041	\$122,885	\$100,126	\$115,380	\$188,606	\$77,319	\$52,110	\$66,404	\$246,232	\$322,818	\$221,543	\$56,485	\$79,588	\$135,755

According to the above Table 3-6, the monthly manpower cost of each personnel (From Table 3-5) and the percentage of effort time allocation are applied into Equation (1) to calculate the manpower cost of each functional element. For instance, the manpower cost of Administration (ADM) element is:

$$\begin{aligned}
 \text{Manpower Cost}_{\text{ADM}} &= \text{Manpower Cost}_{\text{ADM}(002)} + \text{Manpower Cost}_{\text{ADM}(003)} + \\
 &\quad \text{Manpower Cost}_{\text{ADM}(004)} + \text{Manpower Cost}_{\text{ADM}(005)} + \\
 &\quad \text{Manpower Cost}_{\text{ADM}(006)} \\
 &= (88,289 \times 1\%) + (75,340 \times 1\%) + (75,340 \times 1\%) + \\
 &\quad (55,509 \times 80\%) + (40,991 \times 80\%) \\
 &= 883 + 753 + 753 + 44,407 + 32,793 \\
 &= 79,588 \text{ Baht/month}
 \end{aligned}$$

After that, by using the same method the monthly manpower cost of the other element should also be calculated and the results as shown in Table 3-6 above.

The next step is the calculation of the total manpower cost of each functional element for the total working time of this project, which can be calculated by applying the Equation (2) below:

$$\begin{aligned}
 \text{Total Manpower} &= (\text{Manpower Cost} \times \text{Total Working Time})_{\text{functional element}} \\
 \text{Cost functional} & & \dots(2) \\
 \text{element} & &
 \end{aligned}$$

The total working time of each functional element that is gathered from the 'Project Schedule' is shown in the following Table 3-7. The Project Schedule of this study is attaches in Figure A-1 on Appendix A.

According to Table 3-8, the monthly manpower cost (Table 3-6) and the total working time (Table 3-7) of each functional element are applied into the Equation (2) to calculate the total manpower cost of each functional element.

Table 3-7: Total working time of each cost object within the case project.

Source: Simple Cycle Power Plant Construction Project Schedule, RPPCP, EGAT.

Functional Elements		Total Working Time	
Package No.	Description	Days	Months
GT	GAS TURBINE SYSTEM		
0411	ALIGNMENT CHECK	104	3.5
0417	COOLING&SEALING AIR SYS.	47	1.6
0422	GAS FUEL SYSTEM	36	1.2
0424	LIQUID FUEL SYSTEM	11	0.4
0425	ATOMIZING AIR SYSTEM	16	0.5
0442	GT COMPRESSOR WASHING SYS.	15	0.5
0461	WATER WASH SYSTEM	14	0.5
0462	WATER INJECTION SYSTEM	10	0.3
0469	INLET GUIDE VANE SYSTEM	7	0.2
0471	INLET&EXHAUST SYSTEM	42	1.4
0477	FUEL PURGE SYSTEM	10	0.3
0700	COMBUSTOR INSTALLATION	36	1.2
GEN	GENERATOR SYSTEM		
0440-1	GENERATOR	99	3.3
0440-2	SEAL OIL SYSTEM	45	1.5
0440-3	COOLING & PURGE SYS.	22	0.7
AUX	COMMON FACILITY		
0416	LUBE OIL SYSTEM	134	4.5
0420	COOLING WATER SYSTEM	30	1.0
0421	STARTING SYSTEM	10	0.3
0426	FIRE PROTECTION SYSTEM	10	0.3
0436	HVAC	45	1.5
M/S	MATERIALS SUPPLY	158	5.3
W/S	WORKSHOP	95	3.2
OVHC	STORE CRANE	158	5.3
ADM	ADMINISTRATION	240	8.0
PPMC	PROJECT PLANNING, MANAGEMENT& CONTROL	240	8.0

Table 3-8: Total manpower cost for each of cost object.					
Cost Object		Total Working Time		Manpower Cost Distribution	Total Manpower Cost
Package No.	Description	(Days)	(Months)	(Baht/Month)	(Baht)
GT	GAS TURBINE SYSTEM				
0411	ALIGNMENT CHECK	104	3.5	฿115,344	฿399,858
0417	COOLING&SEALING AIR SYS.	47	1.6	฿41,124	฿64,428
0422	GAS FUEL SYSTEM	36	1.2	฿86,051	฿103,262
0424	LIQUID FUEL SYSTEM	11	0.4	฿89,725	฿32,699
0425	ATOMIZING AIR SYSTEM	16	0.5	฿46,311	฿24,699
0442	GT COMPRESSOR WASHING SYS.	15	0.5	฿45,074	฿22,537
0461	WATER WASH SYSTEM	14	0.5	฿46,613	฿21,753
0462	WATER INJECTION SYSTEM	10	0.3	฿50,943	฿16,981
0469	INLET GUIDE VANE SYSTEM	7	0.2	฿25,355	฿5,916
0471	INLET&EXHAUST SYSTEM	42	1.4	฿159,571	฿223,400
0477	FUEL PURGE SYSTEM	10	0.3	฿40,448	฿13,483
0700	COMBUSTOR INSTALLATION	36	1.2	฿18,041	฿21,650
GEN	GENERATOR SYSTEM				
0440-1	GENERATOR	99	3.3	฿122,885	฿405,521
0440-2	SEAL OIL SYSTEM	45	1.5	฿100,126	฿150,189
0440-3	COOLING & PURGE SYS.	22	0.7	฿115,380	฿84,612
AUX	COMMON FACILITY				
0416	LUBE OIL SYSTEM	134	4.5	฿188,606	฿842,439
0420	COOLING WATER SYSTEM	30	1.0	฿77,319	฿77,319
0421	STARTING SYSTEM	10	0.3	฿52,110	฿17,370
0426	FIRE PROTECTION SYSTEM	10	0.3	฿66,404	฿22,135
0436	HVAC	45	1.5	฿246,232	฿369,348
M/S	MATERIALS SUPPLY	158	5.3	฿322,818	฿1,700,176
W/S	WORKSHOP	94.8	3.2	฿221,543	฿700,076
OVHC	STORE CRANE	158	5.3	฿56,485	฿297,487
ADM	ADMINISTRATION	240	8.0	฿79,588	฿636,707
PPMC	PROJECT PLANNING, MANAGEMENT& CONTROL	240	8.0	฿135,756	฿1,086,050
					฿7,340,294

3.5.2 Supplies

From the gathering step in section 3.3.3.2, the total supplies cost of the MPD is approximately 925,000 Baht per month. Moreover, according to accounting records of MPD, this project (SCPPCP) consumed supplies approximately 10% of all supplies that the MPD consumed. So the monthly supplies cost of this project is approximately 92,500 Baht per month. Then, the total cost of supplies of this project in 8 months is 740,000 Baht.

In order to distribute the supplies cost into each functional element, the percentage of supplies usage is required. The percentage of supplies usage of this project was gathered from interviewing all personnel in this project. The percentage of supplies usage and total supplies cost of each functional element is calculated as shown in Table 3-9 below.

3.5.3 Rental Equipment

The following is the explanation how to gather the resource driver information of the Rental Equipment portion in relating to Table 3-2 above.

3.5.3.1 Cars

There are total six cars that are used within this project. However, the usage time of each car is fairly different from each other.

- One sedan car was provided for the management level of the MPD, i.e. the Chief of MPD that used this car in this project about only 10 percent of its total usage time. Whereas the remaining usage time should be charged to another project of the MPD.
- The other four pick-up cars were mainly assigned to be sharing among operational elements of this project. This means that these four cars could be used by other functional elements if it were available.
- The last one is the van car, which is assigned to be a pooling service car for the entire employee of MPD. From the cost information gathering in section 3.3.3.3, the rental cost for the van car that was charged on the MPD is 20,000 Baht per month. Moreover, by using gathering form to collect data from all employees, it

Table 3-9: The percent of supplies usage and average cost for this project.

Overall Supplies Cost	Project's Consumption	Project's Duration	Project's Supplies Cost	
Average (Baht/Month)	Approx. (%)	(Months)	Average (Baht)	
฿925,000	10.0	8.0	฿740,000	
The total supplies cost distribution into each of cost object.				
Cost Object		Project's Supplies Cost	Usage	Total Supplies Cost
Package No.	Description	Average (Baht)	(%)	(Baht)
<i>GT</i>	<i>GAS TURBINE SYSTEM</i>			
0411	ALIGNMENT CHECK	฿740,000	5	฿37,000
0417	COOLING&SEALING AIR SYS.	฿740,000	4	฿29,600
0422	GAS FUEL SYSTEM	฿740,000	3	฿22,200
0424	LIQUID FUEL SYSTEM	฿740,000	5	฿37,000
0425	ATOMIZING AIR SYSTEM	฿740,000	3	฿22,200
0442	GT COMPRESSOR WASHING SYS.	฿740,000	2	฿14,800
0461	WATER WASH SYSTEM	฿740,000	2	฿14,800
0462	WATER INJECTION SYSTEM	฿740,000	2	฿14,800
0469	INLET GUIDE VANE SYSTEM	฿740,000	0.5	฿3,700
0471	INLET&EXHAUST SYSTEM	฿740,000	2	฿14,800
0477	FUEL PURGE SYSTEM	฿740,000	2	฿14,800
0700	COMBUSTOR INSTALLATION	฿740,000	0.5	฿3,700
<i>GEN</i>	<i>GENERATOR SYSTEM</i>	฿740,000		
0440-1	GENERATOR	฿740,000	5	฿37,000
0440-2	SEAL OIL SYSTEM	฿740,000	4	฿29,600
0440-3	COOLING & PURGE SYS.	฿740,000	5	฿37,000
<i>AUX</i>	<i>COMMON FACILITY</i>	฿740,000		
0416	LUBE OIL SYSTEM	฿740,000	5	฿37,000
0420	COOLING WATER SYSTEM	฿740,000	2	฿14,800
0421	STARTING SYSTEM	฿740,000	1	฿7,400
0426	FIRE PROTECTION SYSTEM	฿740,000	3	฿22,200
0436	HVAC	฿740,000	3	฿22,200
<i>M/S</i>	<i>MATERIALS SUPPLY</i>	฿740,000	10	฿74,000
<i>W/S</i>	<i>WORKSHOP</i>	฿740,000	2	฿14,800
<i>OVHC</i>	<i>STORE CRANE</i>	฿740,000	1	฿7,400
<i>ADM</i>	<i>ADMINISTRATION</i>	฿740,000	23	฿170,200
<i>PPMC</i>	<i>PROJECT PLANNING, MANAGEMENT & CONTROL</i>	฿740,000	5	฿37,000
Total Supplies Costs			100	฿740,000

found that this project uses this van approximately 30% of total usage time. Thus, the rental cost of this van that charged on this project is approximately 6,000 Baht per month.

Therefore, the percentage of usage time that allocated on each functional element in related with each rental car is summarised in Table 3-10 in the next page.

After gathering all resource driver of each rental car, the car rental cost of each functional element can be calculated by applying the Equation (3) below:

$$\text{Rental Equipment Cost } j = \sum (\text{Rental Cost } i \times \% \text{ of Time Allocation } i) \quad \dots(3)$$

Where i = Equipment identification number that uses in that functional element.

j = Functional element identification number.

According to Table 3-10, the monthly rental cost of each car and the percentage of usage time allocation are applied into Equation (3) and then calculated the car rental cost of each functional element. For instance, the monthly car rental cost that charged on Gas Fuel System (0422) element is as illustrated below:

$$\begin{aligned} \text{Car Rental Cost}_{0422} &= \text{Rental Cost}_{0422}(\text{RE002}) + \text{Rental Cost}_{0422}(\text{RE003}) + \\ &\quad \text{Rental Cost}_{0422}(\text{RE006}) \\ &= (13,900 \times 3\%) + (7,450 \times 6\%) + (6,000 \times 4\%) \\ &= 417 + 447 + 240 \\ &= 1,104 \text{ Baht/month} \end{aligned}$$

Then, the monthly car rental cost of the other elements should also be calculated by using the same method and as also shown in Table 3-10.

Table 3-10: The percentage of usage time and cost distribution on each of rental equipment and cost object within this project.

Rental Equipment			Usage Time Allocation (%)																								
			Gas Turbine System										Generator Sys.			Common Facilities					Materials	Workshop	Crane	Admin.	Proj.Man.		
Equipment ID/Type/Cost			0411	0417	0422	0424	0425	0442	0461	0462	0469	0471	0477	0700	0440-1	0440-2	0440-3	0416	0420	0421	0426	0436	M/S	W/S	OVHC	ADM.	PPMC
Rental Car																											
RE00	Sedan Car	\$19,200																								10	
RE00	Pick-Up Car	\$13,900	3	3	3	3	3	3	3	3	3	3	3	3	3	3	3	3	3	3	3	3	10	10	5	5	10
RE00	Pick-Up Car	\$7,450	6	6	6	6	6	6	6	6	6	6	6	6													
RE00	Pick-Up Car	\$7,450													8	8	8	8	8	8	8	8					
RE00	Pick-Up Car	\$7,450	6								6			3	3		6					8	60	5	3		
RE00	Van	\$6,000	4	4	4	4	4	4	4	4	4	4	4	4	4	4	4	4	4	4	4	4	5	5	5	5	
Total Cost (Bath/Month)			\$1,551	\$1,104	\$1,104	\$1,104	\$1,104	\$1,104	\$1,104	\$1,104	\$1,104	\$1,551	\$1,104	\$1,104	\$1,477	\$1,477	\$1,253	\$1,700	\$1,253	\$1,253	\$1,253	\$1,849	\$10,928	\$2,063	\$1,219	\$995	\$3,310
Computer&Copy Machine																											
RC00	Computer Set	\$2,000	2	2	2	2	2	2	2	2	2	2	2	2	2	2	2	2	2	2	2	2	10	2	1	40	7
RC00	Copy Machin	\$3,600	2	2	2	2	2	2	2	2	2	2	2	2	2	2	2	2	2	2	2	2	10	2	1	40	7
Total Rental Comp.Cost (Bath/Mo)			\$112	\$112	\$112	\$112	\$112	\$112	\$112	\$112	\$112	\$112	\$112	\$112	\$112	\$112	\$112	\$112	\$112	\$112	\$112	\$112	\$560	\$112	\$56	\$2,240	\$392
Total Rental Cost (Bath/Month)			\$1,663	\$1,216	\$1,216	\$1,216	\$1,216	\$1,216	\$1,216	\$1,216	\$1,216	\$1,663	\$1,216	\$1,216	\$1,589	\$1,589	\$1,365	\$1,812	\$1,365	\$1,365	\$1,365	\$1,961	\$11,488	\$2,175	\$1,275	\$3,235	\$3,702

The next step is the calculation of the total car rental cost of each functional element for the total 8 months of this project as illustrated in Table 3-11 on the next page, which can be calculated by using Equation (4) as below:

$$\text{Total Rental Equipment Cost } j = \sum (\text{Rental Equip. Cost } i \times \text{Total Usage Time } i)_j \quad \dots(4)$$

Where i = Equipment identification number that uses in that functional element.
 j = Functional element identification number.

3.5.3.2 Computer & Accessories

One set of computers were occupied and assigned by the project to be the shared computers for all functional elements. The percentage of computer usage of this project was gathered from interviewing all personnel in this project. The monthly rental cost of computer and accessories of functional elements of this project can be calculated by using the same equation of car rental cost, i.e. Equation (3).

The percentage of usage time of computer and its total monthly rental cost that incurred on each functional element is calculated as shown in Table 3-10 above.

3.5.3.3 Copy machine

To distribute the rental cost of copy machine into each functional element, The percentage of usage time is required for calculation. The percentage of usage of copy machine of this project was gathered from interviewing all personnel in this project. So, the percentage of copy machine usage and total rental cost of copy machine of each functional element is calculated as also shown in Table 3-10 above.

According to Table 3-11 below, the total working time of each element (Table 3-7) and the monthly car rental cost, computer, and copy machine of each functional element (Table 3-10) are applied into Equation (4) to calculate the total rental equipment cost of each functional element.

Cost Object		Total Working Time		Allocated Rental Cost	Total Rental Cost
Package No	Description	(Days)	(Months)	(Baht/Month)	(Baht)
<i>GT</i>	<i>GAS TURBINE SYSTEM</i>				
0411	ALIGNMENT CHECK	104	3.5	฿1,663	฿5,765
0417	COOLING&SEALING AIR SYS.	47	1.6	฿1,216	฿1,905
0422	GAS FUEL SYSTEM	36	1.2	฿1,216	฿1,459
0424	LIQUID FUEL SYSTEM	11	0.4	฿1,216	฿446
0425	ATOMIZING AIR SYSTEM	16	0.5	฿1,216	฿649
0442	GT COMPRESSOR WASHING SYS.	15	0.5	฿1,216	฿608
0461	WATER WASH SYSTEM	14	0.5	฿1,216	฿567
0462	WATER INJECTION SYSTEM	10	0.3	฿1,216	฿405
0469	INLET GUIDE VANE SYSTEM	7	0.2	฿1,216	฿284
0471	INLET&EXHAUST SYSTEM	42	1.4	฿1,663	฿2,328
0477	FUEL PURGE SYSTEM	10	0.3	฿1,216	฿405
0700	COMBUSTOR INSTALLATION	36	1.2	฿1,216	฿1,459
<i>GEN</i>	<i>GENERATOR SYSTEM</i>	0	0.0		
0440-1	GENERATOR	99	3.3	฿1,589	฿5,244
0440-2	SEAL OIL SYSTEM	45	1.5	฿1,589	฿2,384
0440-3	COOLING & PURGE SYS.	22	0.7	฿1,365	฿1,001
<i>AUX</i>	<i>COMMON FACILITY</i>	0	0.0		
0416	LUBE OIL SYSTEM	134	4.5	฿1,862	฿8,317
0420	COOLING WATER SYSTEM	30	1.0	฿1,365	฿1,365
0421	STARTING SYSTEM	10	0.3	฿1,365	฿455
0426	FIRE PROTECTION SYSTEM	10	0.3	฿1,365	฿455
0436	HVAC	45	1.5	฿1,961	฿2,942
<i>M/S</i>	<i>MATERIALS SUPPLY</i>	158	5.3	฿11,488	฿60,503
<i>W/S</i>	<i>WORKSHOP</i>	94.8	3.2	฿2,175	฿6,873
<i>OVHC</i>	<i>STORE CRANE</i>	158	5.3	฿1,275	฿6,715
<i>ADM</i>	<i>ADMINISTRATION</i>	240	8.0	฿3,235	฿25,880
<i>PPMC</i>	<i>PROJECT PLANNING, MANAGEMENT& CONTROL</i>	240	8.0	฿3,702	฿29,616
					฿168,030

3.5.4 Rental Heavy Equipment

The rental heavy equipment cost can be simply distributed into each functional element. However, the heavy equipment usage times are still required. By considering the Project Schedule as shown in Figure A-1 in Appendix A and the installation procedure of the project, the heavy equipment usage time can be estimated and collected from the weight of each mechanical equipment that required to be lifting, loading, off-loading, and (or) handling. The usage time of each heavy equipment that required by this project and its total rental cost are summarised in the next Table 3-12.

The following is the calculation example of the total rental heavy equipment cost of each functional element. The total rental cost of heavy equipment used by the Gas Fuel System (0422) can be calculated by using the above Equation (4) as follows.

Total Heavy Equipment Rental Cost ₀₄₂₂	= Rental Cost ₀₄₂₂ (C)+ Rental Cost ₀₄₂₂ (F)
	= (6,200 Baht/day x 1 day)+(22,370 Baht/day x 1 day)
	= 6,200+22,370
	= 28,570 Baht

3.5.5 Facilities

The facilities cost was charged to all employees in the project team. So, with referring to the gathering cost information in section 3.3.3.5, this cost should be divided by the number of personnel within the project team.

- **Site Office:** The depreciation cost of site office building was charged to the project is 2,083 Baht per month. There are 66 persons who worked for the project in total duration of 240 days or 8 month. Therefore, this facilities cost per head is 253 Baht.

Table 3-12 :Heavy Equipment Usage for On-Site Material Handling, Off-Loading and Transpotation.

ID.	Description	Baht/Day	Day	Total Cost (Baht)	0411	0417	0422	0424	0425	0442	0461	0462	0469	0471	0477	0700	0440-1	0440-2	0440-3	0416	0420	0421	0426	0436	M/S	W/S	OVHC	ADM.	PFMC
A	Truck Tractor with Hydraulic Trail	฿62,600	2	฿125,200	1												1												
B	Truck Tractor with Trailer =50 To	฿13,165	4	฿52,660					1			1								1	1								
C	Truck Tractor with Trailer =25 To	฿6,200	28	฿173,600	11	2	1	1			1	3		6							1		1	1					
D	Gantry Crane=100Tons	฿54,160	3	฿162,480										3															
E	Mobile Crane=15Tons	฿9,030	53	฿478,590	18	0.5	0	0.5	0	0.5	0.5	0.5	0.5	4	0.5	0.5	15	2.5	5	2.6	0.5	0.5	1	0					
F	Mobile Crane=40Tons	฿22,370	37	฿627,690	11	2	1	1		1	1	3		6	3	3		2			1		1	1					
G	Mobile Crane=80Tons	฿48,150	6	฿288,900					1			1			1	1				1	1								
H	Truck Crane=3 Tons: 6 Wheels	฿2,750	61.5	฿169,125	21			1		1	1	1	1	3	1	1	21	1	1	1		1	1						4.5
I	Truck Crane=5 Tons: 10 Wheels	฿4,970	62.5	฿310,625	15	1											14	4		4	1		1						13.5
J	Fork Lift Truck=5 Tons	฿5,100	30.75	฿156,825	10.5	0	0	0.5	0	0.5	0.5	0.5	0.5	1.5	0.5	0.5	10.5	0.5	0.5	0.5	0	0.5	0.5	0					2.25
K	Fork Lift Truck=10 Tons	฿6,150	33.25	฿204,488	7.5	0.5	0	0	0	0	0	0	0	4.5	0	0	7	2	2	2	0.5	0	0.5	0					6.75
L	Truck 6 Wheels	฿2,520	37.75	฿95,130	14	0	0	0.5	0	0.5	0.5	0.5	0.5	1.5	0.5	0.5	14	0.5	0.5	0.5	0	0.5	0.5	0					2.25
M	Truck 10 Wheels	฿3,430	58.25	฿199,798	11.5	0.5	0	0	0	0	0	0	0	11.5	0	0	11.5	2	1	2	0.5	0	0.5	0					17.25
			417.00	฿3,245,110	฿846,110	฿71,415	฿28,570	฿39,645	฿61,315	฿33,445	฿39,645	฿158,100	฿11,075	฿501,550	฿126,335	฿126,335	฿496,705	฿112,915	฿67,440	฿129,490	฿104,160	฿11,075	฿53,920	฿28,570	฿0	฿197,295	฿0	฿0	฿0

- **Workshop:** The depreciation cost of workshop facilities was charged to the project is 1,875 Baht per month. Although, there are 66 persons who worked for the project in total duration of 8 month, but from the project schedule this project will use this workshop only 160 days. Therefore, this facilities cost per head is 152 Baht.
- **Overhead Crane:** The depreciation costs of each overhead crane was charged to the project is 174,353 Baht per month. However, these two cranes are differently distributed to each functional element. For the overhead crane number 1, there are 66 persons who worked for the project in total usage duration of 8 month. So, the facility cost per head that charged to this project is 21,134 Baht. When considering the Project Schedule for the overhead crane number 2, it usage time is only 2 day of total project duration. So, the facility cost per head that charged to this project is only 176 Baht.

The facilities cost of each functional element as shown in the next Table 3-13 can be calculated by using the Equation (5) below:

$$\mathbf{Facility\ Cost\ } j = \square (\mathbf{Facilities\ Cost\ } i \times \mathbf{\% of\ Time\ Allocation}_i) \quad \dots(5)$$

Where, j = Site Office, Workshop, or Overhead Crane;
 i = Functional Element Identification Number.

So, referring to Table 3-13 and Equation (5), the percentage of time allocation is used to calculate the facility cost of the Site Office, Workshop, and Overhead Cranes of each functional element. For example, the facility cost of the Site Office that was charged into each functional element can be illustrated as below:

$$\begin{aligned} \text{Facilities Cost}_{\text{site office}} &= \text{Fac.Cost}_{0411} + \text{Fac.Cost}_{0417} + \text{Fac.Cost}_{0422} + \dots + \text{Fac.Cost}_{\text{ovhc}} + \\ &\quad \text{Fac.Cost}_{\text{ADM}} + \text{Fac.Cost}_{\text{PPMC}} \\ &= (253 \times 1\%) \times 22 + (253 \times 8\%) + (253 \times 25\%) + (253 \times 45\%) \\ &= 56 + 20 + 63 + 114 \\ &= 253 \text{ Baht} \end{aligned}$$

Table 3-13: The total facility depreciation cost distributed into each of cost object.

Cost Object Package No	Description	Site Office (Baht)			Work Shop (Baht)			Overhead Crane#1 (Baht)			Overhead Crane#2 (Baht)			Total Facility Cost (Baht)
		Depreciation Cost	Usage (%)	Cost Allocated	Depreciation Cost	Usage (%)	Cost Allocated	Depreciation Cost	Usage (%)	Cost Allocated	Depreciation Cost	Usage (%)	Cost Allocated	
GT	GAS TURBINE SYSTEM													
0411	ALIGNMENT CHECK	฿253	1	฿3	฿152	2	฿3	฿21,134	17	฿3,593	฿176	50	฿88	฿3,686
0417	COOLING&SEALING AIR SYS.	฿253	1	฿3	฿152	2	฿3	฿21,134	4	฿845	฿176	0	฿0	฿851
0422	GAS FUEL SYSTEM	฿253	1	฿3	฿152	2	฿3	฿21,134	3	฿634	฿176	0	฿0	฿640
0424	LIQUID FUEL SYSTEM	฿253	1	฿3	฿152	2	฿3	฿21,134	5	฿1,057	฿176	0	฿0	฿1,062
0425	ATOMIZING AIR SYSTEM	฿253	1	฿3	฿152	2	฿3	฿21,134	3	฿634	฿176	0	฿0	฿640
0442	GT COMPRESSOR WASHING SYS.	฿253	1	฿3	฿152	2	฿3	฿21,134	2	฿423	฿176	0	฿0	฿428
0461	WATER WASH SYSTEM	฿253	1	฿3	฿152	2	฿3	฿21,134	2	฿423	฿176	0	฿0	฿428
0462	WATER INJECTION SYSTEM	฿253	1	฿3	฿152	2	฿3	฿21,134	2	฿423	฿176	0	฿0	฿428
0469	INLET GUIDE VANE SYSTEM	฿253	1	฿3	฿152	2	฿3	฿21,134	0.6	฿106	฿176	0	฿0	฿111
0471	INLET&EXHAUST SYSTEM	฿253	1	฿3	฿152	2	฿3	฿21,134	5	฿1,057	฿176	0	฿0	฿1,062
0477	FUEL PURGE SYSTEM	฿253	1	฿3	฿152	2	฿3	฿21,134	2	฿423	฿176	0	฿0	฿428
0700	COMBUSTOR INSTALLATION	฿253	1	฿3	฿152	2	฿3	฿21,134	1	฿211	฿176	0	฿0	฿217
GEN	GENERATOR SYSTEM													
0440-1	GENERATOR	฿253	1	฿3	฿152	2	฿3	฿21,134	22	฿4,649	฿176	50	฿88	฿4,743
0440-2	SEAL OIL SYSTEM	฿253	1	฿3	฿152	2	฿3	฿21,134	4	฿845	฿176	0	฿0	฿851
0440-3	COOLING & PURGE SYS.	฿253	1	฿3	฿152	2	฿3	฿21,134	5	฿1,057	฿176	0	฿0	฿1,062
AUX	COMMON FACILITY													
0416	LUBE OIL SYSTEM	฿253	1	฿3	฿152	2	฿3	฿21,134	5	฿1,057	฿176	0	฿0	฿1,062
0420	COOLING WATER SYSTEM	฿253	1	฿3	฿152	2	฿3	฿21,134	2	฿423	฿176	0	฿0	฿428
0421	STARTING SYSTEM	฿253	1	฿3	฿152	2	฿3	฿21,134	1	฿211	฿176	0	฿0	฿217
0426	FIRE PROTECTION SYSTEM	฿253	1	฿3	฿152	2	฿3	฿21,134	3	฿634	฿176	0	฿0	฿640
0436	HVAC	฿253	1	฿3	฿152	2	฿3	฿21,134	0.5	฿106	฿176	0	฿0	฿111
M/S	MATERIALS SUPPLY	฿253	8	฿20	฿152	2	฿3	฿21,134	10	฿2,113	฿176	0	฿0	฿2,137
W/S	WORKSHOP	฿253	1	฿3	฿152	58	฿88	฿21,134	0	฿0	฿176	0	฿0	฿90
OVHC	STORE CRANE	฿253	1	฿3	฿152	0	฿0	฿21,134	1	฿211	฿176	0	฿0	฿214
ADM	ADMINISTRATION	฿253	26	฿63	฿152	0	฿0	฿21,134	0	฿0	฿176	0	฿0	฿63
PPMC	PROJECT PLANNING, MANAGEMENT & CON	฿253	45	฿114	฿152	0	฿0	฿21,134	0	฿0	฿176	0	฿0	฿114
Total Depreciation Cost (Baht/Head)			100	฿253		100	฿152		100	฿21,134		100	฿176	฿21,714

Moreover, the total facilities cost of each functional element for the total 8 months of this project as summarised in the above Table 3-13 can be calculated by using the Equation (6) as follows:

$$\text{Total Facility Cost}_i = \sum (\text{Facilities Cost}_j) \quad \dots(6)$$

Where, j = Site Office, Workshop, or Overhead Crane;

i = Functional Element Identification Number.

Therefore, according to Table 3-13 and Equation (6), the facilities cost of each functional element and time allocation of each element is used to calculate the total facilities cost of each functional elements. For example, the total facility cost that is the summation of site office, workshop, and overhead crane, which charged into functional element of Alignment Check (0411), can be calculated as below:

$$\begin{aligned} \text{Total Facilities Cost}_{0411} &= \text{Fac.Cost}_{\text{Site Office}} + \text{Fac.Cost}_{\text{Workshop}} + \\ &\quad \text{Fac.Cost}_{\text{OVHC1}} + \text{Fac.Cost}_{\text{OVHC2}} \\ &= (253 \times 1\%) + (152 \times 2\%) + (21,134 \times 17\%) + (176 \times 50\%) \\ &= 3 + 3 + 3,593 + 88 \\ &= 3,686 \text{ Baht} \end{aligned}$$

3.5.6 Miscellaneous Expenses

- **Fuel oil supply:** The fuel oil supply cost can be directly distributed into each functional element. However, the cars usage times are required. So by interviewing all personnel of the project team, a car usage time can be estimated and collected. Then the usage time of each car that required by this project and their total fuel costs are summarised in the next Table 3-14.

Table 3-14: The percentage of usage time and cost distribution on each of miscellaneous expense by cost object within this project.

Miscellaneous Expenses			Usage Time Allocation (%)																							
			Gas Turbine System										Generator Sys.			Common Facilities					Materials	Workshop	Crane	Admin.	Proj.Man.	
ID/Type/Cost	0411	0417	0422	0424	0425	0442	0461	0462	0469	0471	0477	0700	0440-1	0440-2	0440-3	0416	0420	0421	0426	0436	M/S	W/S	OVHC	ADM.	PPMC	
Fuel Oil Supply																										
RE00 Sedan Car \$2,550																									10	
RE00 Pick-Up Car \$3,000	3	3	3	3	3	3	3	3	3	3	3	3	3	3	3	3	3	3	3	3	3	10	10	5	5	10
RE00 Pick-Up Car \$3,000	6	6	6	6	6	6	6	6	6	6	6	6									28					
RE00 Pick-Up Car \$3,000													8	8	8	8	8	8	8	8	36					
RE00 Pick-Up Car \$3,000	6									6			3	3		6				8	60	5	3			
RE00 Van \$3,750	4	4	4	4	4	4	4	4	4	4	4	4	4	4	4	4	4	4	4	4	5	5	5	5		
Total Fuel Oil Cost (Baht/Month)	\$500	\$420	\$420	\$420	\$420	\$420	\$420	\$420	\$420	\$600	\$420	\$420	\$570	\$570	\$480	\$660	\$480	\$480	\$480	\$720	\$4,208	\$638	\$428	\$338	\$555	
Water Supply \$2,354	4	4	4	4	4	4	4	4	4	4	4	4	4	4	4	5	4	4	4	4	4	5	4	5	1	
Total Water Sup Cost (Baht/Mon)	\$9,416	\$9,416	\$9,416	\$9,416	\$9,416	\$9,416	\$9,416	\$9,416	\$9,416	\$9,416	\$9,416	\$9,416	\$9,416	\$9,416	\$9,416	\$11,770	\$9,416	\$9,416	\$9,416	\$9,416	\$9,416	\$11,770	\$9,416	\$11,770	\$2,354	
Electricity Supply																										
ES1 Site Office \$3,000																					30			50	20	
ES2 Workshop \$1,400																						100				
ES3 Site Work \$200,000	2	0.5	3	3	3	3	3	3	0.5	4	3	0.5	2	5	8	11	2	2	4	0.5			37			
Total Electricity Cost (Baht/Mont)	\$4,000	\$1,000	\$6,000	\$6,000	\$6,000	\$6,000	\$6,000	\$6,000	\$1,000	\$8,000	\$6,000	\$1,000	\$4,000	\$10,000	\$16,000	\$22,000	\$4,000	\$4,000	\$8,000	\$1,000	\$900	\$1,460	\$74,000	\$1,500	\$600	
Telephone Fee \$3,000																					30	5		5	60	
Security \$22,048	4	4	4	4	4	4	4	4	4	4	4	4	4	4	4	4	4	4	4	4	4	4	4	4	4	
Facility Sustaining \$5,720	4	4	4	4	4	4	4	4	4	4	4	4	4	4	4	4	4	4	4	4	4	4	4	4	4	
Total Utility Cost(Baht/Month)	\$1,111	\$1,111	\$1,111	\$1,111	\$1,111	\$1,111	\$1,111	\$1,111	\$1,111	\$1,111	\$1,111	\$1,111	\$1,111	\$1,111	\$1,111	\$1,111	\$1,111	\$1,111	\$1,111	\$1,111	\$2,011	\$1,261	\$1,111	\$1,261	\$2,911	
Grand Total Misc. Exp. (Baht/Mon)	\$15,127	\$11,947	\$16,947	\$16,947	\$16,947	\$16,947	\$16,947	\$16,947	\$11,947	\$19,127	\$16,947	\$11,947	\$15,097	\$21,097	\$27,097	\$35,541	\$15,007	\$15,007	\$19,007	\$12,247	\$16,534	\$15,068	\$84,954	\$14,868	\$6,420	

- **Water supply:** Water supply cost was charged to all functional elements in the project team. Referring to the cost information gathering in section 3.3.3.6, the water supply cost that was charged to the project is 2,354 Baht per month. And from interviewing all personnel of the project team, a water usage allocation can be estimated and collected as shown in Table 3-14. After that, the water supply cost can be distributed into each functional element of the project as also shown in the same table.
- **Electric Supply:** Electric supply cost was charged to all functional elements in the project team. Referring to the cost information gathering in section 3.3.3.6, there are three places that are account into this expense i.e. the site office, workshop and site work area. These costs are approximately 3,000, 1,400, and 200,000 Baht per month in respectively. Since, the different between its consumption rate and the type of activity. So, these three places should be separately distributed into each of functional element of the project. And from interviewing all personnel of the project team, a power consumption requirement allocation on each place can be separately estimated and collected as shown in Table 3-14. After that, the electricity supply cost can be distributed into each functional element of the project as also shown in the same table.
- **Telephone Fee:** From section 3.3.3.6, the telephone fee of the MPD is approximately 30,000 Baht per month. This project expenses on this cost approximately 10% of the MPD. So, the telephone fee that charged on this project is approximately 3,000 Baht per month. However, telephone fee was charged to all functional elements in the project team except the construction elements because they worked outside the office. Moreover, the telephone usage times are required. Thus by interviewing all personnel of the project team, a phone usage time can be estimated and collected. After that the phone usage time that required by this project and its total cost are summarised in Table 3-14.
- **Security Cost:** Referring to section 3.3.3.6, the security cost of the MPD that charged on this project is approximately 22,048 Baht per month. This cost was charged to all functional elements in the project team. However, the security

coverage areas are required. So by considering the Project Master Plan Layout, the security coverage areas can be estimated and collected. Therefore, the coverage areas that required by this project and its total cost are summarised in Table 3-14.

- **Facility Sustaining:** From section 3.3.3.6, the facility sustaining cost that charged on this project is approximately 5,720 Baht per month. This cost was charged to all functional elements in the project team. However, the sustaining coverage areas are required. By considering the master project plot plan, the coverage areas can be estimated and collected. Then the coverage areas that required by this project and its total cost are also summarised in Table 3-14.

From the reason that the miscellaneous expenses of the project are the summation of six elements of fuel oil supply cost, water supply cost, electric supply cost, telephone fee, security cost and facility sustaining cost. Therefore, the total miscellaneous cost of each functional element can be calculated by using the Equation (7) below:

$$\text{Total Monthly Miscellaneous Expenses } i = \sum (\text{Miscellaneous Cost } j) \quad \dots(7)$$

Where, j = Fuel Oil, Water, Electricity, Telephone, Security, and Facility Sustaining;
 i = Functional Element.

Furthermore, in according to Table 3-14 and Equation (7), the miscellaneous expenses of each functional element and theirs usage ratio are used to calculate the total miscellaneous expenses of each functional elements. For example, the total miscellaneous expenses that is the summation of the Fuel Oil, Water, Electricity, Telephone, Security, and Facility Sustaining, which charged into the functional element of Alignment Check (0411), can be calculated as below:

$$\begin{aligned}
\text{Total Monthly} &= \text{Misc.Cost}_{\text{Fuel Oil}} + \text{Misc.Cost}_{\text{Water}} + \\
\text{Miscellaneous} &= \text{Misc.Cost}_{\text{Electricity}} + \text{Misc.Cost}_{\text{Telephone}} + \\
\text{Expenses}_{0411} &= \text{Misc.Cost}_{\text{Security}} + \text{Misc.Cost}_{\text{Facility Sustaining}} \\
&= (3,000 \times \\
&\quad 3\% + 2 \times 3,000 \times 6\% + 3,750 \times 4\%) + (2,354 \times 4\%) + (200,000 \times 2\%) + (0) \\
&\quad + (22,048 \times 4\%) + (5,720 \times 4\%) \\
&= 600 + 9,416 + 4,000 + 0 + 882 + 229 \\
&= 15,127 \text{ Baht/month}
\end{aligned}$$

$$\text{Overall Misc. Expenses}_i = (\text{Total Monthly Misc. Expenses}_i \times \text{Working Time}_i) \dots (8)$$

Where, i = Functional Element or Cost Objects.

By using the information from the project duration (Table 3-7), Table 3-14, and Equation (8), the overall miscellaneous expenses for each of functional element can be calculated and summarised in Table 3-15. For example, the overall miscellaneous expenses of the Alignment Check (0411) element can be calculated as below:

$$\begin{aligned}
\text{Overall} &= (\text{Total Monthly Misc.Exp}_{0411} \times \text{Working Time}_{0411}) \\
\text{Miscellaneous} & \\
\text{Expenses}_{0411} &= (15,127 \text{ Baht/month} \times 3.5 \text{ months}) \\
&= 52,439 \text{ Baht.}
\end{aligned}$$

The final distributions of all costs within the cost structure that were charged to the entire functional elements of this project are summarised and shown in Table 3-16 below.

Table 3-15: Total miscellaneous expenses on each of cost object.					
Cost Object		Total Working Time		Allocated miscellaneous expenses	Total miscellaneous expenses
Package No.	Description	(Days)	(Months)	(Baht/Month)	(Baht)
GT	GAS TURBINE SYSTEM				
0411	ALIGNMENT CHECK	104	3.5	฿15,127	฿52,439
0417	COOLING&SEALING AIR SYS.	47	1.6	฿11,947	฿18,717
0422	GAS FUEL SYSTEM	36	1.2	฿16,947	฿20,336
0424	LIQUID FUEL SYSTEM	11	0.4	฿16,947	฿6,214
0425	ATOMIZING AIR SYSTEM	16	0.5	฿16,947	฿9,038
0442	GT COMPRESSOR WASHING SYS.	15	0.5	฿16,947	฿6,473
0461	WATER WASH SYSTEM	14	0.5	฿16,947	฿7,908
0462	WATER INJECTION SYSTEM	10	0.3	฿16,947	฿5,649
0469	INLET GUIDE VANE SYSTEM	7	0.2	฿11,947	฿2,788
0471	INLET&EXHAUST SYSTEM	42	1.4	฿19,127	฿26,777
0477	FUEL PURGE SYSTEM	10	0.3	฿16,947	฿5,649
0700	COMBUSTOR INSTALLATION	36	1.2	฿11,947	฿14,336
GEN	GENERATOR SYSTEM				
0440-1	GENERATOR	99	3.3	฿15,097	฿49,819
0440-2	SEAL OIL SYSTEM	45	1.5	฿21,097	฿31,645
0440-3	COOLING & PURGE SYS.	22	0.7	฿27,007	฿19,805
AUX	COMMON FACILITY				
0416	LUBE OIL SYSTEM	134	4.5	฿35,541	฿158,749
0420	COOLING WATER SYSTEM	30	1.0	฿15,007	฿15,007
0421	STARTING SYSTEM	10	0.3	฿15,007	฿5,002
0426	FIRE PROTECTION SYSTEM	10	0.3	฿19,007	฿6,336
0436	HVAC	45	1.5	฿12,247	฿18,370
M/S	MATERIALS SUPPLY	158	5.3	฿16,534	฿87,080
W/S	WORKSHOP	94.8	3.2	฿15,068	฿47,616
OVHC	STORE CRANE	158	5.3	฿84,954	฿447,426
ADM	ADMINISTRATION	240	8.0	฿14,868	฿118,946
PPMC	PROJECT PLANNING, MANAGEMENT & CONTRO	240	8.0	฿6,420	฿51,358
	Grand Total				฿1,235,483

Table 3-16: Overall cost on each of cost object of this project.

Cost Object		Total Manpower Cos	Total Supplies Cost	Total Rental Cost	Heavy Equipment	Total Facility Cos	Total miscellaneous expenses	Grand Total Operational Cost
Package No	Description	(Baht)	(Baht)	(Baht)	(Baht)	(Baht)	(Baht)	(Baht)
GT	GAS TURBINE SYSTEM							
0411	ALIGNMENT CHECK	\$399,858	\$37,000	\$5,765	\$846,110	\$3,686	\$52,439	\$1,344,858
0417	COOLING&SEALING AIR SYS.	\$64,428	\$29,600	\$1,905	\$71,415	\$851	\$18,717	\$186,915
0422	GAS FUEL SYSTEM	\$103,262	\$22,200	\$1,459	\$28,670	\$640	\$20,336	\$176,466
0424	LIQUID FUEL SYSTEM	\$32,899	\$37,000	\$446	\$39,645	\$1,062	\$6,214	\$117,266
0425	ATOMIZING AIR SYSTEM	\$24,699	\$22,200	\$649	\$61,315	\$640	\$9,038	\$118,541
0442	GT COMPRESSOR WASHING SYS.	\$22,637	\$14,800	\$608	\$33,445	\$428	\$8,473	\$80,292
0481	WATER WASH SYSTEM	\$21,753	\$14,800	\$687	\$39,645	\$428	\$7,908	\$85,102
0462	WATER INJECTION SYSTEM	\$16,981	\$14,800	\$405	\$158,100	\$428	\$5,649	\$196,363
0499	INLET GUIDE VANE SYSTEM	\$5,916	\$3,700	\$284	\$11,075	\$111	\$2,788	\$23,874
0471	INLET&EXHAUST SYSTEM	\$223,400	\$14,800	\$2,328	\$501,650	\$1,052	\$26,777	\$769,918
0477	FUEL PURGE SYSTEM	\$13,483	\$14,800	\$405	\$126,335	\$428	\$5,649	\$161,100
0700	COMBUSTOR INSTALLATION	\$21,650	\$3,700	\$1,459	\$126,335	\$217	\$14,336	\$167,697
GEN	GENERATOR SYSTEM							
0440-1	GENERATOR	\$405,521	\$37,000	\$5,244	\$496,705	\$4,743	\$49,819	\$999,032
0440-2	SEAL OIL SYSTEM	\$160,189	\$29,600	\$2,384	\$112,915	\$851	\$31,645	\$327,583
0440-3	COOLING & PURGE SYS.	\$84,612	\$37,000	\$1,001	\$67,440	\$1,062	\$19,805	\$210,920
AUX	COMMON FACILITY							
0416	LUBE OIL SYSTEM	\$842,439	\$37,000	\$8,317	\$129,480	\$1,062	\$158,749	\$1,177,057
0420	COOLING WATER SYSTEM	\$77,319	\$14,800	\$1,365	\$104,160	\$428	\$15,007	\$213,079
0421	STARTING SYSTEM	\$17,370	\$7,400	\$465	\$11,075	\$217	\$5,002	\$41,519
0426	FIRE PROTECTION SYSTEM	\$22,135	\$22,200	\$455	\$53,920	\$640	\$6,336	\$105,685
0436	HVAC	\$369,348	\$22,200	\$2,942	\$28,570	\$111	\$18,370	\$441,541
M/S	MATERIALS SUPPLY	\$1,700,176	\$74,000	\$66,503	\$0	\$2,137	\$87,080	\$1,923,897
WS	WORKSHOP	\$700,076	\$14,800	\$6,673	\$197,295	\$90	\$47,616	\$966,750
OVHC	STORE CRANE	\$297,487	\$7,400	\$9,715	\$0	\$214	\$447,426	\$759,241
ADM	ADMINISTRATION	\$636,707	\$170,200	\$25,880	\$0	\$63	\$118,946	\$951,796
PPMC	PROJECT PLANNING, MANAGEMENT & CO	\$1,088,050	\$37,000	\$29,616	\$0	\$114	\$51,358	\$1,204,137
		\$7,340,294	\$740,000	\$168,030	\$3,245,110	\$21,714	\$1,235,483	\$12,750,630

จุฬาลงกรณ์มหาวิทยาลัย

3.6 Activity-Based Cost Allocation

Having gathered all the concerning costs within the cost structure to each functional element of the project. Those cost should then be allocated to the installation activity of the project. In this study, the cost of each functional element of the project team will be allocated into the activity model by using the basis of two- stage allocation system of Activity-Based Costing as discussed below:

Stage-One Cost Allocation

The concept of stage-one activity-based cost allocation is to trace all overhead costs to activity cost pools that associated with the distinct activity cost drivers. This procedure involves in identifying activities and attributing the related costs that incurred to perform the activities as the following step:

- Identify categories of functional elements; and
- Attributing all overhead costs to activity cost pools.

Stage-Two Cost Allocation

This is the last stage in activity-based cost estimating system. The concept of stage-two activity-based cost allocation is to assign overhead costs to jobs, products, operational elements, or cost objects that based on its individual activity overhead cost rates for the activities. This could be computed as a ratio of overhead costs accumulated in each activity cost pool to the corresponding level of the activity cost driver as through the following steps:

- Identifying activity cost drivers;
- Gathering activity driver information;
- Obtaining activity driver rates; and
- Tracing Costs to Cost Objects.

3.6.1 Stage-One Cost Allocation

3.6.1.1 Identify Category of Functional Elements

Prior to tracing all overhead costs to activity cost pools, the twenty-five functional elements that are considered during the in section 3.4.1 (Perform Cost Object Analysis) should be classified. Since, each organisational element differently serves

as one of these three functions: managerial, support, or operational. In this study, the categories of functional elements of this project team are identified in the following Table 3-17. However, the descriptions of each of these functions are as defined below:

- **Managerial:** Managerial elements serve as the project management, planning, leadership, coordination and control of the project. Management element does not contribute directly to the project's output.
- **Supporting:** All service element costs are indirect costs because they do not arise from direct production activities.
- **Operational:** Operational or Production elements are the elements that arise from direct production activities and contribute directly to the output.

3.6.1.2 Attributing all overhead costs to activity cost pools

Cost allocation is the step that traces all overhead costs to activity cost pools. This means that the costs that were gathered and divided within the cost structure will be allocated to the activity cost pools. Thus, the cost of each activity is the cost of resource that the activity converts inputs into outputs.

In order to final allocate overhead costs to the activities, it requires additional information. The additional information is the allocation bases or percentage of working or efforts time for each activity that each functional element needs to finish work. This information comes from interviewing the personnel(s) in each corresponding element and their head. Moreover, details studying the project schedule (see Figure A-1 in Appendix A), installation procedures, instruction manuals, and other concerned documents can also collect the allocation bases. The percentage of time allocation will be distributed into the activity cost pools level by level. First, the percentage of workload of each functional element will be distributed into the first level or macro activities of the activity model (A1, A2, A3, A4, A5, A6, and A7). After that, the proportion values of time that was allocated on each first level activity of the model will then be distributed into the next sub-activities of each macro activity (e.g.A31, A32, and A33 of A3). This means that the percentage of time allocation on each macro activity will be equal to the summation of the percentage of its next level sub-activities or micro activities.

Cost Object		Cost Categories
Package No.	Description	
GT	GAS TURBINE SYSTEM	
0411	ALIGNMENT CHECK	Operational
0417	COOLING&SEALING AIR SYS.	Operational
0422	GAS FUEL SYSTEM	Operational
0424	LIQUID FUEL SYSTEM	Operational
0425	ATOMIZING AIR SYSTEM	Operational
0442	GT COMPRESSOR WASHING SYS.	Operational
0461	WATER WASH SYSTEM	Operational
0462	WATER INJECTION SYSTEM	Operational
0469	INLET GUIDE VANE SYSTEM	Operational
0471	INLET&EXHAUST SYSTEM	Operational
0477	FUEL PURGE SYSTEM	Operational
0700	COMBUSTOR INSTALLATION	Operational
GEN	GENERATOR SYSTEM	
0440-1	GENERATOR	Operational
0440-2	SEAL OIL SYSTEM	Operational
0440-3	COOLING & PURGE SYS.	Operational
AUX	COMMON FACILITY	
0416	LUBE OIL SYSTEM	Operational
0420	COOLING WATER SYSTEM	Operational
0421	STARTING SYSTEM	Operational
0426	FIRE PROTECTION SYSTEM	Operational
0436	HVAC	Operational
M /S	MATERIALS SUPPLY	Support
W/S	WORKSHOP	Support
OVHC	STORE CRANE	Support
ADM	ADMINISTRATION	Support
PPMC	PROJECT PLANNING, MANAGEMENT& CONTROL	Managerial

For example, according to Table 3-18, the Combustor Installation (0700) element needs only two major activities to complete the work, i.e. activity A4 (Lifting On-Base) and A7 (Painting & Insulating). Referring to the project schedule (Figure A-1 in Appendix A), the total working days (Table 3-7) that this element worked for the project is 36 days, the time allocation that this team worked for activity A4 and A7 are 35 and 1 days respectively. So, the percentage of time allocation on activity A4 and A7 will be 99.45% and 0.55 %, corresponding. When considering activity A4 of element 0700, it needs three sub-activities to finish work, i.e. A41 (Lifting & Hauling), A42 (Setting & Levelling), A43 (Inserting & Assembly). The time allocation of activity A41, A42, and A43 are 30.28%, 10.84%, and 58.33% respectively. After that considering activity A7 of element 0700, it needs only one of four sub-activities to finish work, i.e. A74 (Labelling & Tagging) and its time allocation is 0.55%. This illustrated that the percentage of time allocation of macro activity (e.g. A4 and A7) will be equal to the sum of its micro activities.

This process will be repeated until the percentage of workload is distributed into the last micro activity or activity cost pool. In this study, the percentage of time allocation of each operational element is shown in Table 3-18.

Having discovered all the percentage of time allocation on each activity cost pool, it should be appropriated to calculate the cost of each activity. To traces the overhead costs of the organisation into activity cost pools, the percentage of time allocation of each activity that is performed by each operational element from Table 3-18 is multiplied by it related overhead cost of each functional cost from Table 3-16.

For instance, the total overhead cost of Combustor Installation element (0700) is 167,697 Baht (Table 3-16) and the time allocation of this element on activities A4 and A7 (Table 3-18) are 99.45% and 0.55 % respectively. So, the cost of activity A4 and A7 that were performed by the Combustor Installation element (0700), which is calculated based on percentage of time allocation will be:

Table 3-18: The percentage of time allocation on each of operational cost object by each activity

NODE	Description	Operational Time Allocation (%)																			
		Gas Turbine System										Generator Sys.			Common Facilities						
		0411	0417	0422	0424	0425	0442	0461	0462	0469	0471	0477	0700	0440-1	0440-2	0440-3	0416	0420	0421	0426	0436
A3	Foundation Preparing	12.906	0.000	13.975	7.250	9.025	0.000	5.536	8.025	3.003	3.436	0.000	0.000	8.451	1.901	6.495	4.229	4.305	35.833	5.475	0.550
A31	Interface Verifying	3.190		0.250	2.250	4.025		1.250	2.500	0.500	0.175			0.370	0.250	0.450	0.125	0.426	9.167	0.475	0.300
A32	Embedments Installing	3.888		5.832	2.000	2.000		1.786	1.025	0.750	1.449			3.030	0.587	4.545	2.239	2.380	14.167	2.000	0.250
A33	Setting&Grouting	5.628		7.843	3.000	3.000		2.500	2.500	1.753	1.812			5.051	1.064	1.500	1.866	1.500	12.500	3.000	0.000
A4	Lifting On-Base	79.052	0.000	13.998	36.784	41.341	0.000	19.441	16.833	17.489	76.978	0.000	99.450	83.028	14.578	13.455	8.843	47.215	58.167	9.786	19.139
A41	Lifting/Hauling	27.085		6.155	9.091	9.091		7.143	4.083	7.143	32.378		30.278	12.121	4.265	7.955	2.985	11.667	8.174	4.643	8.003
A42	Setting&Levelling	28.315		7.843	18.182	21.366		7.226	4.500	10.096	30.739		10.839	21.212	6.642	5.500	2.239	2.500	24.409	5.143	3.333
A43	Inserting/Assembling	19.041									13.116		58.333	41.356					26.631		
A44	Aligning&Coupling	3.361			9.486	10.859		5.047	8.000		0.725			7.781	4.655		3.569	6.357	25.333		7.778
A45	Key Fixing	1.250			0.025	0.025		0.025	0.050	0.250	0.020			0.559	0.025		0.050	0.060	0.250		0.025
A5	System Piping	0.000	79.981	47.302	33.811	29.671	82.306	40.658	43.618	19.286	1.957	68.276	0.000	2.800	54.456	70.804	35.448	28.333	0.000	53.323	63.728
A51	Support Installing		6.383	8.863	5.000	5.000	7.500	7.250	8.863	3.571	0.326	8.500			6.383	7.167	2.985	5.000		9.818	16.667
A52	Fitting-Up/Centering		45.936	22.694	15.667	16.371	48.936	20.500	23.529	7.143	0.725	33.500			25.541	34.091	15.672	11.667		23.259	31.277
A53	Welding/Bolting/Sealing		21.279	11.765	9.183	5.339	21.279	10.765	11.765	5.000	0.725	21.776			18.277	22.727	14.926	8.333		17.765	14.839
A54	NDT			4.019	2.000	2.000					3.671				4.265	4.545	1.866				
A55	Leak/Pressure Testing		6.383	1.961	1.961	1.961	4.591	2.143	1.461		0.181	4.500		2.800		2.273		3.333		2.481	0.944
A6	System Cleaning	0.000	19.769	10.954	19.382	17.190	17.194	27.447	17.287	59.572	2.840	13.250	0.000	0.000	21.675	7.410	44.359	19.768	0.000	16.250	8.333
A61	Flush-Pipes Installing		0.475	0.250	0.450	0.450	0.450	2.447	0.550	1.739	0.050	0.250			1.064	0.473	3.731	0.833		1.000	1.111
A62	Initial Filling						0.500	2.500	1.750						2.407		4.478	8.333			
A63	Flushing/Blowing-Down		14.894	9.804	18.182	16.000	11.844	18.929	12.500	54.262	2.536	12.500			16.821	6.187	31.850	8.925		12.500	3.333
A64	Final Restoration		4.400	0.900	0.750	0.740	4.400	3.571	2.467	3.571	0.254	0.500			2.383	0.750	4.300	1.667		2.750	3.889
A7	Painting& Insulating	8.042	0.250	13.771	2.773	2.773	0.500	6.919	16.437	0.650	14.790	18.474	0.550	5.721	7.391	1.836	7.121	0.389	6.000	15.166	8.250
A71	Surface Preparing	1.145							3.500		2.797	6.819		2.020	1.596	0.300	1.793		2.500	4.500	0.950
A72	Preventive Coating	6.897							12.437		0.942	10.165		3.700	5.263	0.400	4.782		3.000	9.500	1.800
A73	Insulating&Lagging			13.280	2.273	2.273		6.169			10.797										5.000
A74	Labelling/Tagging		0.250	0.490	0.500	0.500	0.500	0.750	0.500	0.650	0.254	1.500	0.550		0.532	1.136	0.546	0.389	0.500	1.166	0.500
		100.000	100.000	100.000	100.000	100.000	100.000	100.000	100.000	100.000	100.000	100.000	100.000	100.000	100.000	100.000	100.000	100.000	100.000	100.000	100.000

The cost of activity A4 (Element 0700) = $167,697 \times 99.45\% = 166,775$ Baht
 The cost of activity A7 (Element 0700) = $167,697 \times 0.55\% = 922$ Baht

The cost of other activities or sub-activities can be calculated as the same method as the calculation of this example. In this study, the activity cost was calculated and the result is shown in Table 3-19.

After that, the total cost of each activity cost pool should be calculated by the summation of cost of each functional element that performed that activity. For example, activity Insulation & Lagging (A73) is performed by six operational elements which are Gas Fuel (0422) element, Liquid Fuel (0424) element, Atomizing Air (0425) element, Water Wash (0461) element, Inlet & Exhaust (0471) element, and HVAC (0436) element. Therefore, the cost of activity A73 is the summation of the cost of all those six operational elements. The total cost of activity A73 is calculated as follows:

Cost of activity A73 = Summation of cost of each operational element that do activity A73
 = $23,436+2,665+2,694+5,250+83,129+22,077$
 = 98,142 Baht

Not only for the operational costs that can be traced into its related activity cost pools, but also for the managerial and supporting costs elements. Since, the Project Planning (PPMC) and Material Supply (M/S) elements are associated with the two major activities A1 (Advance planning) and A2 (Equipment receiving). Therefore, the costs can be traced to the activity cost pools by using the same methods as performed by operational elements this as shown in the next Table 3-20.

Table 3-19: The cost distribution on each of operational cost object by each activity

NODE	Description	Operational Cost Allocation (Baht)																				Total
		Gas Turbine System										Generator Sys.			Common Facilities							
		0411	0417	0422	0424	0425	0442	0461	0462	0469	0471	0477	0700	0440-1	0440-2	0440-3	0416	0420	0421	0426	0436	
		\$1,344,858	\$188,915	\$176,466	\$117,266	\$118,541	\$80,292	\$85,102	\$196,383	\$23,874	\$769,918	\$161,100	\$167,697	\$999,032	\$327,583	\$210,920	\$1,177,057	\$213,079	\$41,519	\$105,685	\$441,541	\$6,944,808
A3	Foundation Framing	\$173,561	\$0	\$24,562	\$1,502	\$10,698	\$0	\$4,711	\$7,519	\$717	\$25,453	\$0	\$0	\$84,426	\$8,226	\$13,700	\$49,793	\$4,173	\$14,878	\$5,286	\$2,428	\$443,225
A31	Interface Verifying	\$42,896	\$0	\$441	\$2,638	\$4,771	\$0	\$1,064	\$597	\$119	\$1,347	\$0	\$0	\$3,696	\$819	\$949	\$1,471	\$906	\$3,806	\$502	\$1,325	\$67,343
A32	Embedments Installing	\$52,292	\$0	\$10,380	\$2,345	\$2,371	\$0	\$1,520	\$2,013	\$179	\$11,158	\$0	\$0	\$30,274	\$1,922	\$9,587	\$26,352	\$5,071	\$5,882	\$2,114	\$1,104	\$164,554
A33	Setting&Grouting	\$78,373	\$0	\$13,840	\$3,518	\$3,656	\$0	\$2,128	\$4,909	\$419	\$13,948	\$0	\$0	\$50,456	\$3,485	\$3,164	\$21,960	\$3,196	\$5,190	\$3,171	\$0	\$211,212
A4	Lifting On-Base	\$1,063,137	\$0	\$24,701	\$43,135	\$45,006	\$0	\$16,545	\$32,681	\$4,175	\$592,667	\$0	\$169,775	\$29,478	\$47,754	\$28,376	\$104,088	\$100,806	\$24,150	\$10,242	\$84,506	\$3,222,105
A41	Lifting/Hauling	\$364,249	\$0	\$10,861	\$10,681	\$10,776	\$0	\$6,079	\$8,018	\$1,705	\$249,286	\$0	\$50,776	\$121,095	\$13,940	\$16,778	\$35,136	\$24,859	\$3,394	\$4,907	\$36,336	\$987,854
A42	Setting&Levelling	\$380,802	\$0	\$13,840	\$21,321	\$26,327	\$0	\$6,149	\$8,836	\$2,410	\$236,666	\$0	\$18,177	\$211,916	\$18,482	\$11,601	\$26,352	\$5,327	\$10,135	\$5,436	\$14,718	\$1,017,435
A43	Inserting/Assembling	\$256,080	\$0	\$0	\$0	\$0	\$0	\$0	\$0	\$0	\$100,982	\$0	\$97,823	\$413,165	\$0	\$0	\$0	\$56,744	\$0	\$0	\$0	\$924,784
A44	Aligning&Coupling	\$45,195	\$0	\$0	\$11,124	\$12,873	\$0	\$4,285	\$15,709	\$0	\$5,579	\$0	\$0	\$77,733	\$15,250	\$0	\$42,012	\$13,546	\$10,618	\$0	\$34,342	\$258,176
A45	Key Fixing	\$16,811	\$0	\$0	\$29	\$30	\$0	\$21	\$98	\$60	\$154	\$0	\$0	\$5,580	\$82	\$0	\$689	\$128	\$104	\$0	\$110	\$23,795
A5	System Piping	\$0	\$140,497	\$3,472	\$39,648	\$35,172	\$6,085	\$34,601	\$16,645	\$4,804	\$15,061	\$10,983	\$0	\$27,975	\$178,384	\$149,339	\$417,240	\$60,372	\$0	\$56,364	\$281,384	\$1,794,039
A51	Support Installing	\$0	\$11,931	\$12,110	\$5,883	\$5,927	\$6,022	\$6,170	\$13,476	\$363	\$2,511	\$13,694	\$0	\$0	\$20,910	\$15,117	\$35,136	\$10,654	\$0	\$10,376	\$73,590	\$244,339
A52	Fitting-Up/Centering	\$0	\$85,862	\$40,048	\$18,372	\$18,220	\$39,292	\$17,446	\$46,203	\$1,705	\$5,579	\$53,969	\$0	\$0	\$83,668	\$71,905	\$184,464	\$24,859	\$0	\$24,681	\$138,102	\$854,275
A53	Welding/Bolting/Sealing	\$0	\$39,774	\$20,761	\$10,769	\$6,329	\$17,086	\$9,161	\$23,102	\$1,194	\$5,579	\$35,081	\$0	\$0	\$69,871	\$47,936	\$176,680	\$17,757	\$0	\$18,775	\$65,522	\$534,319
A54	NDT	\$0	\$0	\$7,093	\$2,345	\$2,371	\$0	\$0	\$0	\$853	\$0	\$0	\$0	\$0	\$13,940	\$9,587	\$21,960	\$0	\$0	\$0	\$0	\$68,149
A55	Leak/Pressure Testing	\$0	\$11,931	\$3,460	\$2,300	\$2,325	\$3,686	\$1,824	\$2,868	\$0	\$1,395	\$7,260	\$0	\$27,975	\$0	\$4,794	\$0	\$7,103	\$0	\$2,622	\$4,170	\$53,701
A6	System Cleaning	\$0	\$25,851	\$19,330	\$22,728	\$20,377	\$13,895	\$23,368	\$33,945	\$14,227	\$24,365	\$21,346	\$0	\$0	\$71,023	\$15,830	\$52,130	\$42,491	\$0	\$17,174	\$98,765	\$832,780
A61	Flush-Pipes Installing	\$0	\$888	\$441	\$528	\$533	\$361	\$2,082	\$1,080	\$415	\$385	\$403	\$0	\$0	\$3,485	\$998	\$43,920	\$1,776	\$0	\$1,057	\$4,908	\$63,458
A62	Initial Filling	\$0	\$0	\$0	\$0	\$0	\$401	\$2,128	\$3,436	\$0	\$0	\$0	\$0	\$0	\$7,884	\$0	\$52,704	\$17,767	\$0	\$0	\$0	\$84,319
A63	Flushing/Blowing-Down	\$0	\$27,838	\$17,301	\$21,321	\$18,966	\$9,509	\$16,109	\$24,545	\$12,954	\$19,527	\$20,138	\$0	\$0	\$51,828	\$13,051	\$374,893	\$19,017	\$0	\$13,211	\$14,718	\$674,926
A64	Final Restoration	\$0	\$8,224	\$1,588	\$879	\$877	\$3,533	\$3,039	\$4,884	\$853	\$1,953	\$806	\$0	\$0	\$7,806	\$1,582	\$50,613	\$3,551	\$0	\$2,996	\$17,171	\$110,206
A7	Painting&Insulating	\$108,158	\$467	\$24,301	\$3,261	\$3,267	\$401	\$6,888	\$32,276	\$165	\$113,870	\$20,762	\$122	\$57,150	\$4,211	\$3,873	\$63,615	\$829	\$2,481	\$16,026	\$36,427	\$641,962
A71	Surfaces Preparing	\$15,396	\$0	\$0	\$0	\$0	\$0	\$0	\$6,673	\$0	\$21,635	\$10,986	\$0	\$20,182	\$6,227	\$633	\$21,099	\$0	\$1,038	\$4,766	\$4,195	\$111,920
A72	Preventive Coating	\$92,761	\$0	\$0	\$0	\$0	\$0	\$0	\$24,421	\$0	\$7,253	\$16,360	\$0	\$36,967	\$17,241	\$844	\$56,285	\$0	\$1,246	\$10,040	\$7,948	\$271,366
A73	Insulating&Lagging	\$0	\$0	\$23,436	\$2,685	\$2,694	\$0	\$5,250	\$0	\$0	\$83,129	\$0	\$0	\$0	\$0	\$0	\$0	\$0	\$0	\$0	\$0	\$136,250
A74	Labelling/Tagging	\$0	\$467	\$865	\$586	\$593	\$401	\$638	\$982	\$155	\$1,953	\$2,417	\$922	\$0	\$1,742	\$2,397	\$6,430	\$829	\$208	\$1,232	\$2,208	\$25,023
		\$1,344,855	\$188,915	\$176,466	\$117,266	\$118,541	\$80,291	\$85,102	\$192,050	\$23,874	\$769,919	\$161,100	\$167,697	\$999,030	\$327,582	\$210,921	\$1,177,056	\$213,080	\$41,519	\$105,685	\$441,541	\$6,940,480

NODE	Description	Managerial Cots		Support Costs		Final Distribution
		PPMC		M/S		Total
Managerial Activities		%Effort Time	฿1,204,137	%Effort Time	฿1,923,897	฿3,128,034
A1	Advance Planning	100	฿1,204,137	0	฿0	฿1,204,137
A11	WBS	15	฿180,621	0	฿0	฿180,621
A12	Milestone Laying-Out	10	฿120,414	0	฿0	฿120,414
A13	Organisation Chart	5	฿60,207	0	฿0	฿60,207
A14	Control Network	15	฿180,621	0	฿0	฿180,621
A15	Base-Line Input Data	3	฿36,124	0	฿0	฿36,124
A16	Monitoring Proj. Status	20	฿240,827	0	฿0	฿240,827
A17	Evaluating Performance	32	฿385,324	0	฿0	฿385,324
Supporting Activities						
A2	Equipment Receiving	0	0.0	100	฿1,923,897	฿1,923,897
A21	Equipment Receiving	0	฿0	5	฿96,195	฿96,195
A22	Unloading/Warehousing	0	฿0	35	฿673,364	฿673,364
A23	On-Site Transporting	0	฿0	50	฿961,948	฿961,948
A24	Unpacking&preparing	0	฿0	10	฿192,390	฿192,390

สถาบันวิทยบริการ
จุฬาลงกรณ์มหาวิทยาลัย

3.6.2 Stage-Two Cost Allocation

3.6.2.1 Identifying activity cost drivers

This step is one of the most important steps of the study, since the activity drivers are method for assigning the cost of activities to cost objects. Moreover, they measure how often activities are performed for each type of cost object and the effort involved in carrying them out. Furthermore, the accuracy of the costs that traced into cost objects is directly correlated with their use. Besides that, activity drivers are the linkage between the cost objects and the activities that reflect what causes the costs. However, as suggested by Commonwealth Department of Employment (2000) of AUS, the following are some of the rules that can be assisted in the selection of activity drivers:

- Select activity drivers that match the type of activity;
- Select activity drivers that correlate well with the actual consumption of the activity;
- Minimise the number of distinct drivers;
- Select activity drivers that help in improving a performance;
- Select activity drivers that have an appropriate cost of measurement; and
- Do not select activity drivers that require new measurements.

To analyse activity drivers requires the fully understanding of the activity and its components before making the decision. So, it requires a clearly consideration to answer the questions of what the activity does, what it produces, and how long does it takes to produce the output.

Since the analysis of activity cost drivers is one of the most importance parts of this estimating study, therefore it should be clearly considered, comprehensively appropriated among various cost objects and then verified by experience manager. In this study, the cost drivers are verified by interviewing all concerns persons and discussing with some expertise both internal and external of the project team. The next Table 3-21 is the selected activity drivers, which expected that should properly be used in assigning the cost of activities to each cost object of the case project.

Table 3-21: Identifying activities, activity drivers for assigning cost of activities to cost objects.

Activity		Activity Cost	Activity Cost Drivers			Overhead Rates
NODE	Description		Description	Total Volume	Baht/Unit	
A1	Advance Planning	\$1,204,137				
A11	WBS	\$180,621	# Work Package	20	Pckg	\$9,031.03
A12	Milestone Laying-Out	\$120,414	# Work Package	20	Pckg	\$6,020.69
A13	Organisation Chart	\$60,207	# Work Package	20	Pckg	\$3,010.34
A14	Control Network	\$180,621	# Work Package	20	Pckg	\$9,031.03
A15	Base-Line Input Data	\$36,124	# Work Package	20	Pckg	\$1,806.21
A16	Monitoring Proj. Status	\$240,827	# Progress Report	320	Rprt	\$752.59
A17	Evaluating Performance	\$385,224	# Evaluation Repor	320	Rprt	\$1,204.14
A2	Equipment Receiving	\$1,923,897				
A21	Equipment Receiving	\$96,195	# Man-Days	316	Md	\$304.41
A22	Unloading/Warehousing	\$673,364	# Man-Days	790	Md	\$852.36
A23	On-Site Transporting	\$961,948	# Man-Days	2,054	Md	\$468.33
A24	Unpacking&preparing	\$192,390	# Man-Days	632	Md	\$304.41
A3	Foundation Preparing	\$443,225				
A31	Interface Verifying	\$67,348	# Verifying Areas	3,215	m2	\$20.95
A32	Embedments Installing	\$184,664	# Installing Areas	636	m2	\$258.82
A33	Setting&Grouting	\$211,312	# Grouting Areas	298	m2	\$708.53
A4	Filling On-Base	\$3,222,105				
A41	Lifting/Hauling	\$667,854	# Equip. Weights	1,175	T	\$823.78
A42	Setting&Levelling	\$1,017,495	# Equip. Weights	1,175	T	\$866.03
A43	Inserting/Assembling	\$924,754	# Equip. Weights	917	T	\$1,008.29
A44	Aligning&Coupling	\$248,176	# Man-Days	145	Md	\$1,987.42
A45	Key Fixing	\$23,798	# Man-Days	46	Md	\$517.30
A5	System Piping	\$1,794,639				
A51	Support Installing	\$244,339	# Supporting	1,366	Sets	\$178.94
A52	Fitting-Up/Centering	\$554,275	# Welding Joints	2,763	FW	\$309.18
A53	Welding/Bolting/Sealing	\$554,376	# Welding Joints	2,763	FW	\$200.64
A54	Non-Destructive Testing	\$58,149	# Welding Joints	1,293	FW	\$44.97
A55	Leak/Pressure Testing	\$83,701	# Testing Duration	21	d	\$3,985.76
A6	System Clearing	\$932,700				
A61	Flush-Pipes Installing	\$63,258	# Installing Times	141	Md	\$448.64
A62	Initial Filling	\$64,310	# Filling Times	111	Md	\$762.98
A63	Flushing/Blowing-Down	\$674,825	# Flushing Times	903	Md	\$747.84
A64	Final Restoration	\$110,299	# Restoring Times	189	Md	\$583.42
A7	Painting&Insulating	\$547,562				
A71	Surface Preparing	\$111,920	# Preparing Areas	1,656	m2	\$67.58
A72	Preventive Coating	\$271,366	# Coating Areas	1,656	m2	\$163.87
A73	Insulating&Lagging	\$139,250	# Insulating Areas	266	m2	\$524.43
A74	Labelling/Tagging	\$25,025	# Work Package	20	Pckg	\$1,251.25
WS	Workshop	\$966,750	# Man-Days	1,232	Md	\$784.45
OVHC	Store Crane	\$759,241	# Man-Days	2,054	Md	\$569.64
ADM	Administration	\$951,796	# Work Package	20	Pckg	\$47,589.81
Total Overhead Costs		\$12,750,630				

3.6.2.2 Gathering activity driver information

Having identified an activity cost driver for each activity, it still needs some further step in collecting or capturing an information about their volume that will be used as an allocation bases in tracing each activity cost to each cost object. For example, referring to Table 3-21 above, the number of pipe supports is selected as an activity cost driver for the activity A51 (Support Installing). So, the information about the number of pipe supports (e.g. number of sets) that corresponding with it cost object must be gathered. In this case, the total activity driver volumes that summarised in the 6th Column of Table 3-21 can be captured by details studying of erection drawings, procedures, manuals and all concerned documents for the installation works of the entire cost objects these are as illustrated in the next Table 3-22.

3.6.2.3 Obtaining activity driver rates

An overhead driver or activity cost driver rate is the ratio that is used to allocate the consumption of the activity to the output in the process flow, based on the units of output produced.

Since prior to obtain the activity driver rate, it requires the information about the overall amount of activity driver volume that was captured in the previous step (Table 3-22) and the total cost of the activity that was traced during stage-one allocation (Table 3-19 and 3-20). Then, the activity driver rate can be calculated by using the Equation (9) below:

$$\text{Activity Cost Driver} = (\text{Activity Cost})/(\text{Activity Driver Volumes}) \quad \dots(9)$$

For Example, referring to Table 3-21, when considering the activity A51 (Pipe Support Installing) the activity cost of 244,339 Baht (from Table 3-19) is divided by it assoicated total driver volumes i.e. 1,366 set of pipe support (from Table 3-22). These are to obtain the activity cost driver rate of 178.94 Baht per stes of activity A51 depicts below.

Table 3-22: Capturing the activity driver volumes for each of operational cost object.

Activity		Activity Cost Driver Values for each of Cost Object																				Total		
NODE	Description	Gas Turbine System											Generator Sys.			Common Facilities					Volume	Unit		
		0411	0417	0422	0424	0425	0442	0461	0462	0469	0471	0477	0700	0440-1	0440-2	0440-3	0416	0420	0421	0426	0436			
A1	Advance Planning																							
A11	WBS	1	1	1	1	1	1	1	1	1	1	1	1	1	1	1	1	1	1	1	1	1	20	Pckg
A12	Milestone Laying-Out	1	1	1	1	1	1	1	1	1	1	1	1	1	1	1	1	1	1	1	1	1	20	Pckg
A13	Organisation Chart	1	1	1	1	1	1	1	1	1	1	1	1	1	1	1	1	1	1	1	1	1	20	Pckg
A14	Control Network	1	1	1	1	1	1	1	1	1	1	1	1	1	1	1	1	1	1	1	1	1	20	Pckg
A15	Base-Line Input Data	1	1	1	1	1	1	1	1	1	1	1	1	1	1	1	1	1	1	1	1	1	20	Pckg
A16	Monitoring Proj. Status	16	16	16	16	16	16	16	16	16	16	16	16	16	16	16	16	16	16	16	16	16	320	Rprt
A17	Evaluating Performance	16	16	16	16	16	16	16	16	16	16	16	16	16	16	16	16	16	16	16	16	16	320	Rprt
A2	Equipment Receiving																							
A21	Equipment Receiving	63	9	16	16	6	6	6	6	6	32	3	3	57	6	6	38	6	3	6	19	316	Md	
A22	Unloading/Warehousing	158	24	40	40	16	16	16	16	16	79	8	8	142	16	16	95	16	8	16	47	790	Md	
A23	On-Site Transporting	411	62	103	103	41	41	41	41	41	205	21	21	370	41	41	246	41	21	41	123	2,054	Md	
A24	Unpacking&preparing	126	19	32	32	13	13	13	13	13	63	6	6	114	13	13	76	13	6	13	38	632	Md	
A3	Foundation Preparing																							
A31	Interface Verifying	655		200	15	15		29	38	10	400	12	0	270	15	150	50	330	12	33	983	3,215	m2	
A32	Embedments Installing	164		50	2	2		4	5	1	50	12	0	68	10	38	12	83	6	8	123	636	m2	
A33	Setting&Grouting	44		13	15	15		29	38	10	27	3	0	17	8	5	35	22	2	18	0	298	m2	
A4	Lifting On-Base																							
A41	Lifting/Hauling	289		100	22	22		11	18	7	305		90	230	11	5	51	4	4	2	7	1,175	T	
A42	Setting&Levelling	289		100	22	22		11	18	7	305		90	230	11	5	51	4	4	2	7	1,175	T	
A43	Inserting/Assembling	289									305		90	230				4				917	T	
A44	Aligning&Coupling	35			4	16		2	4		1			49	4		6	12	10		2	145	d	
A45	Key Fixing	9			2	4		2	2	2	1			9	2		4	1	6		2	46	d	
A5	System Piping																							
A51	Support Installing		14	21	47	15	36	26	43	25	23	35			142	174	217	31		160	359	1,366	Sets	
A52	Fitting-Up/Centering		30	43	96	32	74	54	87	52	48	72			285	350	435	63		322	720	2,763	FW	
A53	Welding/Bolting/Sealing		30	43	96	32	74	54	87	52	48	72			285	350	435	63		322	720	2,763	FW	
A54	NDT			43	96	32				52					285	350	435					1,293	FW	
A55	Leak/Pressure Testing		3	2	1	1	1	1	1		1	1		3		2		1		1	2	21	d	

Table 3-22: Capturing the activity driver volumes for each of operational cost object.

Activity		Activity Cost Driver Values for each of Cost Object																					
NODE	Description	Gas Turbine System											Generator Sys.			Common Facilities					Total		
		0411	0417	0422	0424	0425	0442	0461	0482	0469	0471	0477	0700	0440-1	0440-2	0440-3	0416	0420	0421	0426	0436	Volume	Unit
A6	System Cleaning																						
A61	Flush-Pipes Installing		4	12	6	9	28	2	2	6	2	2			8	3	49	2		3	3	141	d
A62	Initial Filling						6	14	14						15		49	13				111	d
A63	Flushing/Blowing-Down		49	35	15	15	6	9	9	25	14	10			100	15	540	10		36	12	903	d
A64	Final Restoration		4	12	6	9	28	2	2	6	2	2	0	0	35	3	70	2		3	3	189	d
A7	Painting& Insulating																						
A71	Surface Preparing	352							175		490	6		220	62	8	250		3	46	45	1,856	m2
A72	Preventive Coating	352							175		490	6		220	62	8	250		3	46	45	1,856	m2
A73	Insulating&Lagging			75	5	5		9			122										49	266	m2
A74	Labelling/Tagging	1	1	1	1	1	1	1	1	1	1	1	1	1	1	1	1	1	1	1	1	20	Pckg
W/S	Workshop	407	12	12	25	25	12	12	12	12	25	12	12	345	25	25	185	12	37	12	12	1,232	Md
OVHC	Store Crane	514	82	21	41	41	21	4	21	21	103	21	41	489	164	82	246	21	82	21	21	2,054	Md
ADM	Administration	1	1	1	1	1	1	1	1	1	1	1	1	1	1	1	1	1	1	1	1	20	Pckg

สถาบันวิทยบริการ
 ภาลงกรณ์มหาวิทยาลัย

Activity Cost Driver (For Activity A51)	= (244,339)/(1,366)
	= 178.94 Baht/set.

The other activity cost driver rates should be calculated by using the same method as the activity A51, so the calculation results for the activity driver rates of each activity cost pools are also illustrated in Table 3-21 above.

3.6.2.4 Tracing Costs to Cost Objects

Having determined activity driver rates, it should be possible to assign overhead costs to cost objects based on each cost driver rate for each of activity cost pools. In this case, the overhead cost is traced to each cost object on the basis of their correspond cost driver rates (as shown in Table 3-21) presents this information for all 20 cost objects. For instance, the details calculation in tracing overhead costs to cost object number 0411 (Alignment Check) is illustrated in the next Table 3-23. The calculation results of this section i.e. the overhead costs that traced to all of cost objects of the case project is displayed in the next Table 3-24

Activity		Activity Cost Drivers		Overhead Rates	Overhead Costs	Calculation Details	
NODE	Description	Description	Volume	Baht/Unit	Baht		
A1 Advance Planning							
A11	WBS	# Work Package	1	Pckg	฿9,031.03	฿9,031 =1.0* B9,031.03	
A12	Milestone Laying-Out	# Work Package	1	Pckg	฿6,020.69	฿6,021 =1.0* B6,020.69	
A13	Organisation Chart	# Work Package	1	Pckg	฿3,010.34	฿3,010 =1.0* B3,010.34	
A14	Control Network	# Work Package	1	Pckg	฿9,031.03	฿9,031 =1.0* B9,031.03	
A15	Base-Line Input Data	# Work Package	1	Pckg	฿1,806.21	฿1,806 =1.0* B1,806.2	
A16	Monitoring Proj. Status	# Progress Report	16	Rprt	฿752.59	฿12,041 =16.0* B9752.59	
A17	Evaluating Performance	# Evaluation Repor	16	Rprt	฿1,204.14	฿19,266 =16.0* B1,204.14	
A2 Equipment Receiving							
A21	Equipment Receiving	# Man-Days	63	Md	฿304.41	฿19,239 =63.0* B304.41	
A22	Unloading/Warehousing	# Man-Days	158	Md	฿852.36	฿134,673 =158.0* B852.36	
A23	On-Site Transporting	# Man-Days	411	Md	฿468.33	฿192,390 =411* B468.33	
A24	Unpacking&preparing	# Man-Days	126	Md	฿304.41	฿38,478 =126.0* B304.41	
A3 Foundation Preparing							
A31	Interface Verifying	# Verifying Areas	655	m2	฿20.95	฿13,715 =655* B20.95	
A32	Embedments Installing	# Installing Areas	164	m2	฿258.82	฿42,362 =164* B258.82	
A33	Setting&Grouting	# Grouting Areas	44	m2	฿708.53	฿30,924 =44* B708.53	
A4 Lifting On-Base							
A41	Lifting/Hauling	# Equip. Weights	289	T	฿823.78	฿237,772 =289* B823.78	
A42	Setting&Levelling	# Equip. Weights	289	T	฿866.03	฿249,967 =289* B866.03	
A43	Inserting/Assembling	# Equip. Weights	289	T	฿1,008.29	฿291,029 =289* B1,008.29	
A44	Aligning&Coupling	# Man-Days	35	Md	฿1,987.42	฿69,560 =35* B1,987.42	
A45	Key Fixing	# Man-Days	9	Md	฿517.30	฿4,656 =9* B517.30	
A5 System Piping							
A51	Support Installing	# Supporting	0	Sets	฿178.94	฿0 n/a	
A52	Fitting-Up/Centering	# Welding Joints	0	FW	฿309.18	฿0 n/a	
A53	Welding/Bolting/Sealing	# Welding Joints	0	FW	฿200.64	฿0 n/a	
A54	Non-Destructive Testing	# Welding Joints	0	FW	฿44.97	฿0 n/a	
A55	Leak/Pressure Testing	# Testing Duration	0	d	฿3,985.76	฿0 n/a	
A6 System Cleaning							
A61	Flush-Pipes Installing	# Installing Times	0	Md	฿448.64	฿0 n/a	
A62	Initial Filling	# Filling Times	0	Md	฿762.98	฿0 n/a	
A63	Flushing/Blowing-Down	# Flushing Times	0	Md	฿747.84	฿0 n/a	
A64	Final Restoration	# Restoring Times	0	Md	฿583.42	฿0 n/a	
A7 Painting& Insulating							
A71	Surface Preparing	# Preparing Areas	352	m2	฿67.58	฿23,799 =352* B67.58	
A72	Preventive Coating	# Coating Areas	352	m2	฿163.87	฿57,703 =352* B163.87	
A73	Insulating&Lagging	# Insulating Areas	0	m2	฿524.43	฿0 n/a	
A74	Labelling/Tagging	# Work Package	1	Pckg	฿1,251.25	฿1,251 =1* B1,251.25	
W/S	Workshop	# Man-Days	407	Md	฿784.45	฿319,028 =407* B784.45	
OVHC	Store Crane	# Man-Days	514	Md	฿369.64	฿189,810 =514* B369.64	
ADM	Administration	# Work Package	1	Pckg	฿47,589.81	฿47,590 =1* B47,589.81	
Total Overhead Costs						฿2,024,151	
Number of Packages						1	
Cost per Unit						฿2,024,151	=B2,024,251/1

Table 3-24: Activity-Based Costs and its cost drivers for each of cost object

Activity		Activity Cost Driver Values for each of Cost Object																						
NODE	Description	C/D Rates	Gas Turbine System											Generator Sys.			Common Facilities					Total		
		Bahr/Unit	0411	0417	0422	0424	0425	0442	0461	0462	0469	0471	0477	0700	0440-1	0440-2	0440-3	0416	0420	0421	0428	0436	Volume	Unit
A1	Advance Planning																							
A11	WBS	\$9,031.03	1	1	1	1	1	1	1	1	1	1	1	1	1	1	1	1	1	1	1	1	20	Pckg
A12	Milestone Laying-Out	\$6,020.69	1	1	1	1	1	1	1	1	1	1	1	1	1	1	1	1	1	1	1	1	20	Pckg
A13	Organisation Chart	\$3,010.34	1	1	1	1	1	1	1	1	1	1	1	1	1	1	1	1	1	1	1	1	20	Pckg
A14	Control Network	\$9,031.03	1	1	1	1	1	1	1	1	1	1	1	1	1	1	1	1	1	1	1	1	20	Pckg
A15	Base-Line Input Data	\$1,806.21	1	1	1	1	1	1	1	1	1	1	1	1	1	1	1	1	1	1	1	1	20	Pckg
A16	Monitoring Proj. Status	\$752.59	16	16	16	16	16	16	16	16	16	16	16	16	16	16	16	16	16	16	16	16	320	Rprt
A17	Evaluating Performance	\$1,204.14	16	16	16	16	16	16	16	16	16	16	16	16	16	16	16	16	16	16	16	16	320	Rprt
A2	Equipment Receiving																							
A21	Equipment Receiving	\$304.41	63	9	16	16	6	6	6	6	32	3	3	57	6	6	38	6	3	6	19	316	Md	
A22	Unloading/Warehousing	\$852.36	158	24	40	40	16	16	16	16	79	8	8	142	16	16	95	16	8	16	47	790	Md	
A23	On-Site Transporting	\$468.33	411	62	103	103	41	41	41	41	205	21	21	370	41	41	246	41	21	41	123	2,054	Md	
A24	Unpacking&preparing	\$304.41	126	19	32	32	13	13	13	13	63	6	6	114	13	13	76	13	6	13	38	632	Md	
A3	Foundation Preparing																							
A31	Interface Verifying	\$20.95	655		200	15	15		29	38	10	400	12	0	270	15	150	50	330	12	33	983	3,215	m2
A32	Embedments Installing	\$258.82	164		50	2	2		4	6	1	50	12	0	68	10	38	12	83	6	8	123	636	m2
A33	Setting&Grouting	\$708.53	44		13	15	15		29	36	10	27	3	0	17	8	5	35	22	2	18	0	298	m2
A4	Lifting On-Base																							
A41	Lifting/Hauling	\$823.78	289		100	22	22		11	18	7	305		90	230	11	5	51	4	4	2	7	1,175	T
A42	Setting&Levelling	\$866.03	289		100	22	22		11	18	7	305		90	230	11	5	51	4	4	2	7	1,175	T
A43	Inserting/Assembling	\$1,008.29	289									305		90	230				4				917	T
A44	Aligning&Coupling	\$1,987.42	35		4	16			2	4		1		49	4		6	12	10		2	145	d	
A45	Key Fixing	\$517.30	9		2	4			2	2	2	1		9	2		4	1	6		2	46	d	
A5	System Piping																							
A51	Support Installing	\$178.94		14	21	47	15	36	26	43	25	23	36		142	174	217	31		160	359	1,366	Sels	
A52	Fitting-Up/Centring	\$309.18		30	43	96	32	74	54	87	52	48	72		285	350	435	63		322	720	2,763	FW	
A53	Welding/Bolting/Sealing	\$200.64		30	43	96	32	74	54	87	52	48	72		285	350	435	63		322	720	2,763	FW	
A54	NDT	\$44.97			43	96	32				52				285	350	435					1,293	FW	
A55	Leak/Pressure Testing	\$3,985.76		3	2	1	1	1	1	1		1	1		3	2			1		1	2	21	d
A6	System Cleaning																							

Table 3-24: Activity-Based Costs and its cost drivers for each of cost objects

Activity			Activity Cost Driver Values for each of Cost Object																					
NODE	Description	C/D Rates	Gas Turbine System												Generator Sys.			Common Facilities					Total	
		Baht/Unit	0411	0417	0422	0424	0425	0442	0461	0462	0469	0471	0477	0700	0440-1	0440-2	0440-3	0416	0420	0421	0426	0436	Volume	Unit
A61	Flush-Pipes Installing	฿448.64		4	12	6	9	28	2	2	6	2	2			8	3	49	2		3	3	141	d
A62	Initial Filling	฿762.98						6	14	14						15		49	13				111	d
A63	Flushing/Blowing-Down	฿747.84		49	35	15	15	6	9	9	25	18	10			100	15	540	10		35	12	903	d
A64	Final Restoration	฿583.42		4	12	6	9	28	2	2	6	2	2	0	0	35	3	70	2		3	3	189	d
A7	Painting & Insulating																							
A71	Surface Preparing	฿67.58	352							175		490	6		220	62	8	250		3	46	45	1,656	m2
A72	Preventive Coating	฿163.67	352							175		490	6		220	62	8	250		3	46	45	1,656	m2
A73	Insulating & Lagging	฿524.43			75	5	5		9			122										49	266	m2
A74	Labelling/Tagging	฿1,251.25	1	1	1	1	1	1	1	1	1	1	1	1	1	1	1	1	1	1	1	1	20	Pckg
W/S	Workshop	฿784.45	407	12	12	25	25	12	12	12	12	25	12	12	345	25	25	185	12	37	12	12	1,232	Md
OVHC	Store Crane	฿369.64	514	82	21	41	41	21	4	21	21	103	21	41	489	164	82	246	21	82	21	21	2,054	Md
ADM	Administration	฿47,589.81	1	1	1	1	1	1	1	1	1	1	1	1	1	1	1	1	1	1	1	1	20	Pckg
Total Overhead Costs			฿2,024,151	฿277,332	฿530,858	฿382,347	฿311,377	฿250,803	฿265,061	฿348,363	฿243,479	฿1,449,699	฿208,875	฿395,967	฿1,726,073	฿571,836	฿471,391	฿1,546,930	฿304,440	฿220,229	฿419,364	฿797,637	฿12,746,312	
Number of Packages			1	1	1	1	1	1	1	1	1	1	1	1	1	1	1	1	1	1	1	1	20	Pckg
Cost per Unit			฿2,024,151	฿277,332	฿530,858	฿382,347	฿311,377	฿250,803	฿265,061	฿348,363	฿243,479	฿1,449,699	฿208,875	฿395,967	฿1,726,073	฿571,836	฿471,391	฿1,546,930	฿304,440	฿220,229	฿419,364	฿797,637	฿12,746,312	

สถาบันวิทยบริการ
จุฬาลงกรณ์มหาวิทยาลัย

Chapter 4

Comparative Analysis and Evaluation

4.1 Introduction

The purpose of this chapter is to:

- Describe the principal and illustrate the results of conventional cost estimation system at the case project.
- Study and analyse the differences between the results from the conventional and activity-based cost estimation system.
- Generate costing report that useful for top management in decision making.
- Evaluation the appropriateness of the ABC models for the case project.

4.2 Conventional System at MPD

In order to do the comparative analysis between the old system and ABC, it is important to make clearly understood the concept of conventional method in product costing systems.

Atkinson et al. (1995: 278-279) discussed that the traditional product costing systems is assigned overhead costs to jobs or products by using Two-stage Cost Allocation method, which firstly defines overhead costs in associated with several production and service departments. After that all of those service costs are reallocated into production departments. The concept of the second stage is to allocate costs from stage one to jobs or products based on production overhead rates calculated as a proportion overhead costs accumulated in each of their department to their respective output measurement level.

However, in conventional method at MPD, the single-based cost allocation is used to assign all mechanical installation overhead costs to 20 jobs or work packages of the Simple Cycle Power Plant. The following diagram illustrates the basic costs flow model or the cost allocation procedure that consists of two main steps:

- First, the total overhead costs are traced to all production, service and managerial functional cost pools.
- Then, redistributed all of the service and managerial costs to the operational functions or work packages.

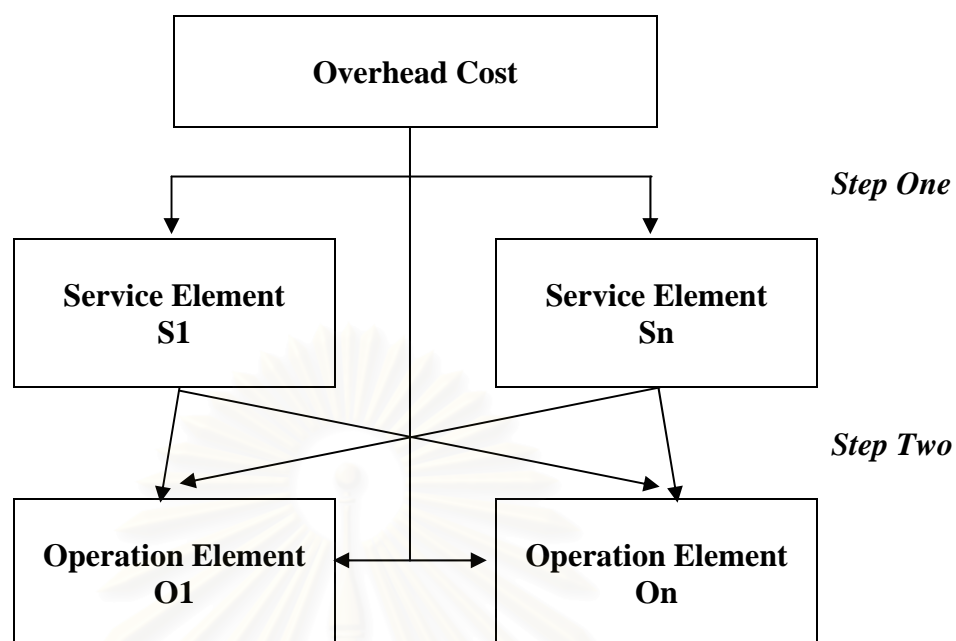

Figure 4-1: Traditional method by Single-Based Cost Allocation at MPD.

4.2.1 Step One of Single-Based Allocation

4.2.1.1 Tracing Cost to Functional Cost Elements

In this stage, all the overhead costs of the project are firstly analysed through four steps, those are cost data scope out, identifies overhead costs, and gathers cost information. It can be notice that this traditional procedure that involves in estimation of the normal overhead costs for the 25 functional elements of the MPD, are using the same approach as of ABC system in section 3.3 (Cost Analysis) and section 3.5 (Gathering Resource Driver Information). Therefore, the same results as depicted in Table 3-16 in previous chapter, can be also used in this section as illustrated in the 3rd column of Table 4-1 below.

4.2.2 Step Two of Single-Based Cost Allocation

4.2.2.1 Reattribute Service Costs to Operation Elements

Having traced all overhead costs into each of managerial, service, and operation elements. This step involves redistributing all of the service and managerial costs into the operation costs.

The conventional costing system at MPD assume that it is inconvenient to determine the direct measures in using the resources of managerial and service functions on each of job or work package as it can of operational functions. This is because the work packages are performed on only in the operational functions.

Thus, the system allocates the overhead costs of managerial and service functions first to the operational functions before allocating them to each of job or work package. This distribution of costs from the service functions to operation functions is the second step in single-based stage of the cost allocation procedure.

Moreover, there are various kinds of method that are applied to reattribute service costs to operation costs. Atkinson et al. (1995: 281) suggested that there are three different methods that used to allocate the service costs to the operation costs, i.e. direct, sequential and reciprocal allocation methods.

This study, however, shall consider only the basis principle that was using at the MPD, which is the direct allocation method as discussed below.

- In order to reattribute managerial and supporting costs to operational costs, it requires some more details about how much cost will be allocated into each operational element. The allocation bases and their values presented in Table 4-1 below is assigned to the operational elements in proportion to their respective allocation basis values. This means that the operational elements, which are served by the managerial and supporting elements will be incurred costs by the ratio of supporting that they receive. The allocation ratios that represent those proportions can be obtained by interviewing the personnel who worked in these managerial and supporting elements.
- Then calculate the amount of costs that will allocate to the operational elements by multiplying the allocation percentage by its related costs. According to Table 4-1 for instance, the Alignment Check element (0411) receives Baht 114,216 (the 7th column) of Administration service element costs (ADM), which determined by multiplying the allocation ratio 12% (the 6th column) by the total overhead costs of Baht 951,796 (the 7th column).

Table 4-1: Traditional method for cost allocation that the support categories served the other categories.

Cost Object		Direct Cost	Service Time (%) and Cost Allocation (Baht)										Total Costs
Package No.	Description	(Baht)	PPMC	\$1,204,137	Admin.	\$951,796	aterial	\$1,923,897	Workshop	\$966,750	OVHC	\$759,241	(Baht)
GT	GAS TURBINE SYSTEM												
0411	ALIGNMENT CHECK	\$1,344,858	17	\$204,703	12	\$114,216	20	\$384,779	37	\$357,698	25	\$189,810	\$2,596,065
0417	COOLING&SEALING AIR SYS.	\$186,915	3	\$36,124	4	\$38,072	3	\$57,717	0.5	\$4,834	3	\$22,777	\$346,439
0422	GAS FUEL SYSTEM	\$176,466	5	\$60,207	4	\$38,072	5	\$96,195	0.5	\$4,834	5	\$37,962	\$413,736
0424	LIQUID FUEL SYSTEM	\$117,266	8	\$96,331	4	\$38,072	5	\$96,195	2	\$19,335	2	\$15,185	\$382,384
0425	ATOMIZING AIR SYSTEM	\$118,541	3	\$36,124	4	\$38,072	2	\$38,478	2	\$19,335	2	\$15,185	\$265,734
0442	GT COMPRESSOR WASHING SYS.	\$80,292	2	\$24,083	4	\$38,072	2	\$38,478	0.5	\$4,834	2	\$15,185	\$200,943
0461	WATER WASH SYSTEM	\$85,102	2	\$24,083	4	\$38,072	2	\$38,478	0.5	\$4,834	2	\$15,185	\$205,753
0462	WATER INJECTION SYSTEM	\$196,363	2	\$24,083	4	\$38,072	2	\$38,478	0.5	\$4,834	2	\$15,185	\$317,014
0469	INLET GUIDE VANE SYSTEM	\$23,874	1	\$12,041	4	\$38,072	1	\$19,239	1	\$9,668	2	\$15,185	\$118,078
0471	INLET&EXHAUST SYSTEM	\$769,918	1	\$12,041	5	\$47,590	10	\$192,390	2	\$19,335	3	\$22,777	\$1,064,051
0477	FUEL PURGE SYSTEM	\$161,100	2	\$24,083	4	\$38,072	1	\$19,239	1	\$9,668	1	\$7,592	\$259,754
0700	COMBUSTOR INSTALLATION	\$167,697	1	\$12,041	4	\$38,072	1	\$19,239	0.5	\$4,834	2	\$15,185	\$257,067
GEN	GENERATOR SYSTEM												
0440-1	GENERATOR	\$999,032	16	\$192,662	10	\$95,180	18	\$346,301	28	\$270,690	23	\$174,625	\$2,078,491
0440-2	SEAL OIL SYSTEM	\$327,583	8	\$96,331	5	\$47,590	2	\$38,478	2	\$19,335	5	\$37,962	\$567,279
0440-3	COOLING & PURGE SYS.	\$210,920	6	\$72,248	4	\$38,072	2	\$38,478	2	\$19,335	4	\$30,370	\$409,423
AUX	COMMON FACILITY												
0416	LUBE OIL SYSTEM	\$1,177,057	15	\$180,621	8	\$76,144	12	\$230,868	15	\$145,013	12	\$91,109	\$1,900,810
0420	COOLING WATER SYSTEM	\$213,079	2	\$24,083	4	\$38,072	2	\$38,478	1	\$9,668	1	\$7,592	\$330,972
0421	STARTING SYSTEM	\$41,519	2	\$24,083	4	\$38,072	1	\$19,239	3	\$29,003	1	\$7,592	\$159,508
0426	FIRE PROTECTION SYSTEM	\$105,685	2	\$24,083	4	\$38,072	3	\$57,717	0.5	\$4,834	2	\$15,185	\$245,575
0436	HVAC	\$441,541	2	\$24,083	4	\$38,072	6	\$115,434	0.5	\$4,834	1	\$7,592	\$631,556
		\$6,944,808	100	\$1,204,137	100	\$951,796	100	\$1,923,897	100	\$966,750	100	\$759,241	\$12,750,630

- The total allocated costs from the managerial and service elements are then added into the overhead costs that originally identified directly with the operation elements. This can be calculated by using the Equation (10) as follow. According to Table 4-1 for instance, the total allocated costs Baht 2,596,065 for the 0411 element (the 4th column) is the sum of the original overhead costs i.e. Baht 1,344,858 (the 3rd column) and the cost allocated from the managerial (PPMC) and the other four support elements cost (ADM, M/S, W/S and OVHC) i.e. Baht 1,251,206 (204,703+114,216+384,779+357,698+189,810).

$\begin{aligned} \textit{Total} \\ \textit{Allocated} \\ \textit{Costs} \end{aligned} = (\textit{Directly Identified Costs}) + (\textit{Service Costs Allocated to it}) \dots(10)$
--

This is to illustrate that the MPD uses the Table 4-1 and Equation (10) to reallocate its managerial and service costs to the operational costs by the direct allocation method.

4.3 Comparative Analysis

Having considered each conceptual and its implementation of the costs estimating system by using ABC and traditional approaches, the differences between these two approaches could be compared and evaluated in terms of their conceptual and cost variances analysis as follows:

4.3.1 Conceptual Comparison

At this level of comparison, the overall concepts and the features of each method is investigated by the extent to what and how ABC represents a major change from traditional costing. In this study, the conceptually differences are summarised in the following table:

Table 4-2: Conceptually comparison between Old system and ABC at MPD.		
Key Conceptual	Traditional System	ABC System
<i>Objective</i>	<ul style="list-style-type: none"> • Primary objective is to assign overhead costs to jobs or products. 	<ul style="list-style-type: none"> • The primary objective of ABC is emphasis on determining the cost of the operational and supporting activities or processes. • Secondary objective is to assign overhead costs to jobs or products.
<i>Cost Allocation</i>	<ul style="list-style-type: none"> • Overhead cost is charged to managerial, support and operational function rather than product. • Redistributed service and managerial costs to operation costs by Direct Cost Allocation method. • Allocation bases do not perfectly reflect the managerial and support costs. 	<ul style="list-style-type: none"> • Overhead cost is charged to the activity rather than product. • Activity usage is based on the number of activity cost drivers consumed by the jobs. • An activity cost driver is the output of the activity and can reflect all functional elements.
<i>Cost Pool</i>	<ul style="list-style-type: none"> • Using the limitation number of cost pools i.e. equal to the number of functional elements. 	<ul style="list-style-type: none"> • A number of cost pools equals to the number of activities.
<i>Total Overhead Costs</i>	<ul style="list-style-type: none"> • Difficult to track the impact of changes in the number of activities for a distinct jobs. 	<ul style="list-style-type: none"> • The influence of changes in the number of activities for a distinct cost object can

		be obtained.
<i>Performance Measurement</i>	<ul style="list-style-type: none"> • Non-financial measures are not related. 	<ul style="list-style-type: none"> • Both of financial and non-financial measures are associated.
<i>Potential Improvement</i>	<ul style="list-style-type: none"> • No indications in cost reduction nor potential improvement. 	<ul style="list-style-type: none"> • Not only providing a high potential in cost reduction, but also performance improvement.

4.3.2 Cost Variances Analysis

In addition to the conceptually comparison discussed above, at this level of comparison, the details analysis in the extent of how much cost distortion that occurred by the traditional system with reference to the ABC system. This is because it is very useful and makes clearer understanding of how much the differentiation of the two systems. So, the costs of the 20 cost objects or work packages under the old and the new costing systems that estimated previously are then used for the cost analysis in this section.

4.3.2.1 Calculations

The variance analysis is very straightforward calculation of how much the old costs deviated from the ABC cost this can be computed by using the following Equation (11) and (12).

$$\text{Cost Variance} = (\text{Traditional Cost}) - (\text{ABC Cost}) \quad \dots(11)$$

$$\% \text{ Cost Variance} = \frac{(\text{Traditional Cost}) - (\text{ABC Cost})}{(\text{ABC Cost})} \times 100 \quad \dots(12)$$

Besides that, by using the cost information of the total cost of each cost object at MPD under the traditional (Table 4-1) and ABC approach (Table 3-24), applying those costs information in corresponding to Equation (11) and (12) above.

- First consequently is the overview of the difference between the two systems that can be compared as show in Figure 4-2 below.
- The next consequent is the cost variance and its distortion that arise from the Old System, depicted as a percent difference from the ABC cost which can be obtained and summarised the results as illustrated in Table 4-3. For instance, referring to Equation (11), the cost variances Baht 571,914 of cost object number 0411 (Alignment Check), which is obtained by subtracting the Old costs of Baht 2,596,065 by the ABC costs of Baht 2,024,151. Then using Equation (12) to obtain the percent of cost variances 28.25% by dividing the cost variances Baht 571,914 by the ABC costs of Baht 2,024,151.

4.3.3 Evaluation Criteria

According to the study of Merz C.M. and Hardy (1993:22-27) that was cited by Atkinson et al. (1995: 293), there are two kinds of criteria that implied as quantitative and qualitative criteria, in order to effectively compare and evaluate the extent of cost variances occurred by the old system. These criteria are selected as evaluation bases for the comparative analysis in this study and defined as below.

4.3.3.1 Quantitative criteria

There is three different quantitative criteria i.e. underestimated, overestimated, and little change. The following are the definitions of each criterion:

- Underestimated: A negative value or percentage of cost variance as a result from the Equation (11) or (12) indicates that the overhead cost estimated by the traditional system is lower than that by the ABC system.
- Overestimated: A positive value or percentage of cost variance as a result from the Equation (11) or (12) indicates that the overhead cost estimated by the traditional system is higher than that by the ABC system.
- Little Change: This criteria is defined that whether a negative or positive percentage of cost variance as a result from the Equation (11) or (12), which are less than 5% indicates that the overhead cost estimated by the traditional system is slightly deviated from the ABC system.

Estimated Costs Comparative Between Traditional and ABC System

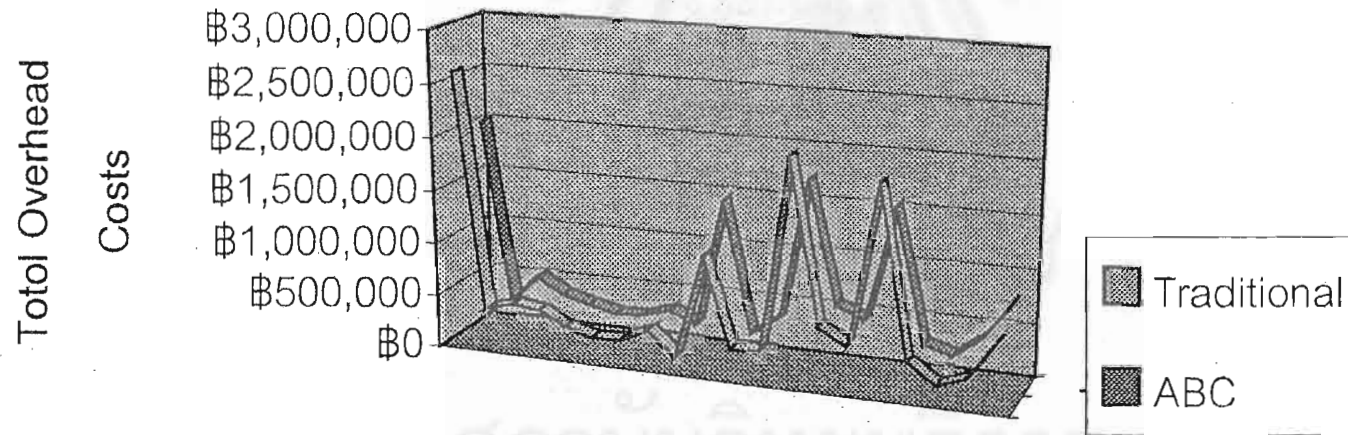

Figure 4-2: Costs comparison between Traditional and ABC method by each of cost object.

Table 4-3: Analysis of variance between the Conventional System and ABC costs.										
Cost Object		Traditional	ABC	Distortion caused by the Traditional System, Expressed as a Difference from ABC						
Package No.	Description	(Baht)	(Baht)	(Baht)	(%)	Over 100%	50%~100%	20%~50%	5%~20%	Less Than 5%
GT	GAS TURBINE SYSTEM									
0411	ALIGNMENT CHECK	฿2,596,065	฿2,024,151	฿571,914	28.25%			Over		
0417	COOLING&SEALING AIR SYS.	฿346,439	฿277,332	฿69,107	24.92%			Over		
0422	GAS FUEL SYSTEM	฿413,736	฿530,858	-฿117,122	-22.06%			Under		
0424	LIQUID FUEL SYSTEM	฿382,384	฿382,347	฿36	0.01%					Over
0425	ATOMIZING AIR SYSTEM	฿265,734	฿311,377	-฿45,643	-14.88%				Under	
0442	GT COMPRESSOR WASHING SYS.	฿200,943	฿250,903	-฿49,960	-19.91%				Under	
0461	WATER WASH SYSTEM	฿205,753	฿265,061	-฿59,308	-22.38%			Under		
0462	WATER INJECTION SYSTEM	฿317,014	฿348,363	-฿31,348	-9.00%				Under	
0469	INLET GUIDE VANE SYSTEM	฿118,078	฿243,479	-฿125,400	-51.50%		Under			
0471	INLET&EXHAUST SYSTEM	฿1,064,051	฿1,449,699	-฿385,648	-26.60%			Under		
0477	FUEL PURGE SYSTEM	฿259,754	฿208,875	฿50,879	24.36%			Over		
0700	COMBUSTOR INSTALLATION	฿257,067	฿395,967	-฿138,900	-35.08%			Under		
GEN	GENERATOR SYSTEM									
0440-1	GENERATOR	฿2,078,491	฿1,726,073	฿352,418	20.42%			Over		
0440-2	SEAL OIL SYSTEM	฿567,279	฿571,836	-฿4,557	-0.80%					Under
0440-3	COOLING & PURGE SYS.	฿409,423	฿471,391	-฿61,968	-13.15%				Under	
AUX	COMMON FACILITY									
0416	LUBE OIL SYSTEM	฿1,900,810	฿1,546,930	฿353,880	22.88%			Over		
0420	COOLING WATER SYSTEM	฿330,972	฿304,440	฿26,531	8.71%				Over	
0421	STARTING SYSTEM	฿159,508	฿220,229	-฿60,722	-27.57%			Under		
0426	FIRE PROTECTION SYSTEM	฿245,575	฿419,364	-฿173,790	-41.44%			Under		
0436	HVAC	฿631,556	฿797,637	-฿166,082	-20.82%			Under		
Total	20 Cost Objects or Packages	฿12,750,630	฿12,750,630	฿0	0.00%	0	1	12	5	2
						0%	5%	60%	25%	10%

4.3.3.2 Qualitative Criteria

There are five different classes of qualitative criteria those are summarised in the table below.

Table 4-4: Qualitative criteria of distortion occurred by the old system, represented as a percent difference from ABC cost.		
Source: Merz C.M. and Hardy (1993:22-27) that cited by Atkinson et al. (1995: 293)		
Class	Criteria	Definitions
1	More than 100%	Distortion of cost variance occurred by the old system, represented as a percent difference from ABC cost more than 100%.
2	Between 50% and 100%	Distortion of cost variance occurred by the old system, represented as a percent difference from ABC cost between 50% and 100%.
3	Between 20% and 50%	Distortion of cost variance occurred by the old system, represented as a percent difference from ABC cost between 25% and 50%.
4	Between 5% and 20%	Distortion of cost variance occurred by the old system, represented as a percent difference from ABC cost between 5% and 20%.
5	Less than 5%	Distortion of cost variance occurred by the old system, represented as a percent difference from ABC less than 5%.

4.4 Comparison Results

Regarding to Table 4-4, the calculation results from Table 4-3 or the overall comparison results of the distortion that arise from the old system expressed as a percent difference from ABC system, the findings can be summarised in Table 4-5 below.

Table 4-5: Distortion occurred by the Traditional System, represented as a percent difference from ABC cost.

Criteria	No. Cost Objects and Percent Distorted from ABC					Total	
	More than 100%	50%~ 100%	20%~ 50%	5%~ 20%	Less than 5%	No.	% of Total
<i>Underestimated</i>	0	1	7	4	0	12	60%
<i>Little Change</i>	0	0	0	0	2	2	10%
<i>Overestimated</i>	0	0	5	1	0	6	30%
<i>Total no. of Cost Objects</i>	0	1	12	5	2	20	100%
<i>% of Total</i>	0%	5%	60%	25%	10%	100%	

It can be seen from the above table that at the MPD, when comparing the costs of its 20 cost objects or packages under the old and the ABC costing systems. The extent of cost distortion caused by the old system can be concluded in terms of both qualitative and quantitative analysis as following:

4.4.1 Quantitative Results

The three important proportions of the quantitative indicators are illustrated in the following diagram and concluded as below:

- There are 12 out of total 20 packages or 60% of packages that are underestimated.
- There are only 2 out of total 20 packages or 10% of packages that are slightly change.
- There are 6 out of total 20 packages or 30% of packages that are overestimated.

This indicates that for the product cost of MPD, in each of its total 20 packages there are only 2 packages (10% of Total) that are slightly change, whereas 18 out of its (90% of Total) have high significantly change.

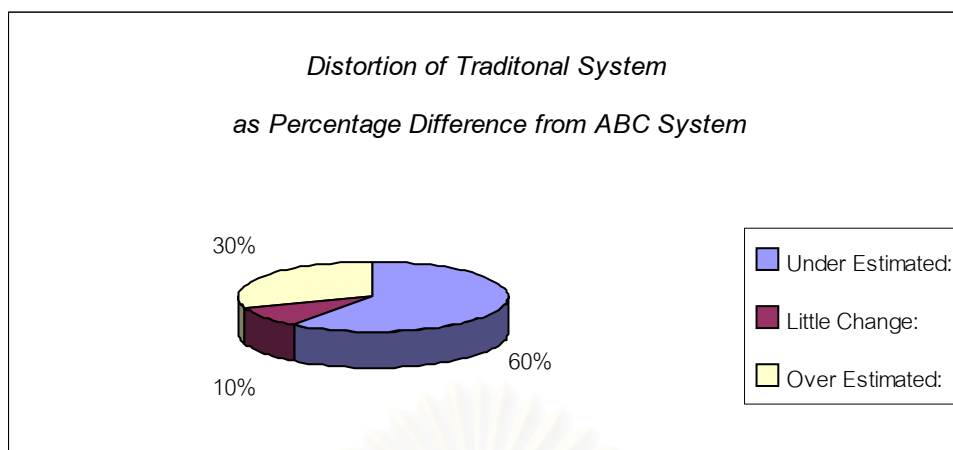

Figure 4-3: Quantitative results of the distortion between traditional and ABC.

4.4.2 Qualitative Results

Having evaluated the extent of cost distortion by quantitative analysis, it should be advantages to evaluate the other extent of cost distortion i.e. qualitative results. The five proportions of the qualitative indicators are illustrated in the following diagram and concluded as below:

- There is no any package that has the percentage of cost variance more than 100%.
- There is only 1 out of total 20 packages or 5% of packages that the percentage cost variance falls between the range of 50% and 100%.
- There are 12 out of total 20 packages or 60% of packages that the percentage cost variance falls between the range of 20% and 50%.
- There are 5 out of total 20 packages or 25% of packages that the percentage cost variance falls between the range of 5% and 20%.
- There are 2 out of total 20 packages or 10% of packages that have the percentage of cost variance less than 5%.

These mean that there are 13 out of total 20 packages or 75% of packages that have the percentage of cost variances more than 20% over or under the ABC costs.

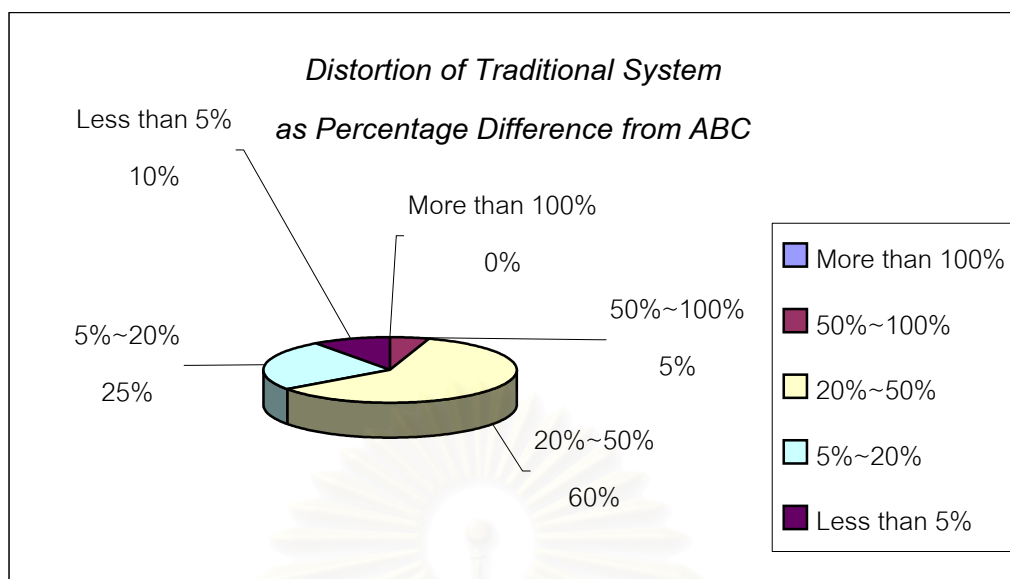

Figure 4-4: Qualitative results of the distortion between traditional and ABC.

4.5 Costing Report

After finding the differences between the old and ABC system, it should be more beneficial to generate the costing report. Since, a useful report is one of the effective and powerful communication tools in strategic decision making. Turney (1996:288) suggested that the criteria of such a useful report should be understandable, relevant, accurate, timely and up to date. Moreover, as argued by Marrow, ed. (1992:113) that generally the costing reports should be compared the actual versus estimated activity costs, which will provide the top management with clearer understanding of how effectively they are using the resources. Furthermore, Olomolaiye P.O. et al. (1998:17) discussed that the appropriate implementation of cost control system or cost reporting may be identified some alarms on cost overrun for each activity. So, the following three reports can be prepared to support the project management in the decision making of cost management and process improvement issues of the project:

- ‘Activity cost report’ that summarises cost per activity;
- ‘Cost per cost objects report’ that evaluates cost per cost object; and
- ‘Activity unit cost and benchmarking report’ that examines each of the activity unit cost of the case project in comparison with two other unit costs i.e. the ‘Average unit cost’ and the ‘Best practice unit cost’.

The examples of costing reports for the case project that are relevant with these three types of reports are illustrated in Appendix B.

4.6 Model Evaluation

This section is to evaluate not only the appropriateness of the ABC model for the case project, but also its beneficial and limitations as discussed below:

4.6.1 Appropriateness of ABC

The ABC could be usefully applied with the case project to estimate and determine how much its costs to provide the installation services more accurately than traditional method as for the following reasons:

- The case project is the construction project that typically consumes high overhead costs and uses labour intensive, which has considerably high complexity of the installation process and high variety of job. The manpower cost of this case is approximately 57.57% of total overhead costs.
- The overhead cost is charged directly to the activity cost pools rather than directly to service or jobs.
- The influence of changes in the number of activities for a distinct cost object can be easily obtained.
- Quantitative evidence from the previous comparative analysis indicates that in each of its total 20 packages there are only 2 packages (10% of total) that the old system are slightly deviated from ABC (less than 5% of cost variance). Whereas 18 out of its (90% of total) have high significantly deviated, those are underestimated (12 packages or 60% of total) and overestimated (6 packages or 30% of total).
- Qualitative evidence shows that there are 13 out of total 20 packages (or 75% of packages) that the traditional have deviated more than 20% of cost variances over or under the ABC costs.

4.6.2 Benefit of ABC

ABC is a powerful tool that contributes in understanding the efficiency and effectiveness of the installation process operated by the case project as concluded below:

- The more accurate in estimating installation costs reported by Activity-Based Costing system is the better in improving cost management and supporting

decisions making. Since, it can provide a useful information that help in effectively monitoring and control of target outcomes.

- The activity cost flow model helps in identifying the value contributed by activities and project team functional elements, through a comprehensive explaining why and how the overhead cost charged into jobs or products.
- Activity model and its activity cost pools contribute to differentiating between activities provided to different jobs, which is a strategic information that need for efficiently process improvement. Since, activity usage is based on the number of activity cost drivers consumed by individual jobs.
- An activity cost driver is the output of the activity and can reflect all overhead costs that are incurred by managerial, supporting and operation costs. So, it can helps to identify opportunities to effectively use of project resources or cost reduction.
- This study could be possible to use as a pilot project for the other power plant construction projects that may need to be analysed their cost by using ABC.

4.6.3 Discussion and Limitation of ABC

The overall discussion associated with the previous sections of this study in terms of its limitations, problems, difficulties and other key learning points are summarised as below:

- Although, ABC has a scope to ensure that only the necessary data is gathered. But, it stills required a lot of time and effort, and consumed cost for determining cost information, and gathering data through its level of details.
- Scope of the cost data in the case project is limited such as it included only the mechanical installation process, however, in the real situation of construction project it can not avoid any risks or uncertainties from both internal or external of the process. So, the costs impact from those uncertainties on the study could be possible incurred and then distorted the estimation.
- The ABC system in this study uses so many allocation bases and supporting information, costing errors is then sensitively occurred. Moreover, the cost distortion can be occurred, because some of confidential cost information, lack of information, updating of information.

- The over time cost is included in the overhead cost structure in this study, since in the traditional cost reporting, this cost is also including. Moreover, it would be easier to do the comparative analysis between the two systems.
- Although, the cost drivers used in this study are based on the interviewing and discussion with a cross-functional manager who concerned with the project. But, due to the time constraint of this study. Therefore, in rare case it may not appropriate for tracing activity cost to the corresponding cost object. The same limitation and reason are also notice for the activity cost pools.
- Many costing reports are simple in concept, but it can be complicated to successfully implement. This means that it is very important at the planning and design stages of the study to ensure the availability of some information and its feasibility. For example of the 'Benchmarking Report', the 'Average Industrial Unit Cost' and the 'Best Practice Unit Cost' are treated as confidential data of the private company so in comparison, the prices were used instead of costs. Moreover, these prices are lower than those cost of the case organisation from the reason that company's business strategy is the 'Cost leadership' with the capability to effectively allocate resources among many projects that are located on the nearby area. Furthermore, the case organisation is the state enterprise with the strategy of the 'Customer Focus' that concentration on quality and reliability.
- The most requirement of tasks performed in this ABC study is to attribute or identify where people and resources spend time across the various activities or elements. Since there are only few techniques that were used in this study such as interviews and discussions, therefore where possible, it should be very useful if the combination of others techniques should be used to enhance the accuracy of this information. For instance, those of the other techniques are surveys, discussion, interviews, workshop, storyboard and so on.
- Typically, there are three different cost allocation methods (i.e. direct, sequential and reciprocating) used by the traditional system to allocate the managerial and service costs into the operation costs. However, the traditional method in this study is direct method that used in the comparison with the ABC system. This means that if the case project used the other two traditional methods to compare with the ABC system, the results and findings should be changed in relation to their method.

Chapter 5

Conclusion

5.1 Conclusion

In dealing with such a large and complex engineering-based construction projects under this economic crisis environment project management should be able to assess project objectives (i.e. performance, costs, or time) in associate with project status and then make timely strategic decisions in fast responding to change. For example of the case project, even though the traditional cost systems possess a wealth of information pertaining to project status, they cannot readily utilise accounting data for operations based reporting. Moreover, the job or contract costs are often so inaccurate, management is forced to allocate overhead rather than try to eliminate waste and improve project performance. Consequently, this crucial issue is immediately calls for the cost management that can particularly analysis, estimating and reporting more accurate cost of activities.

Therefore, the objective of this study is to develop a cost estimation system by Activity-Based Costing approach for the mechanical installation works of the Simple Cycle Power Plant Construction Project.

The expected results of the study consist of three key areas i.e. supporting top management in commercial decision making, identifying opportunities to improve the mechanical installation activities and piloting the other projects.

The implementation of cost estimation system by ABC model in this study has eight steps as summarised below:

- 'Perform Activity Analysis' is the first step that all concerned activities of the project will be analysed by using Work breakdown Structure (WBS) and IDEF0 modeling techniques to develop the activity model. Within this model the macro activities were decomposed into micro activities and illustrated with it related input, control, output and mechanism (ICOM) that can explain how the activity transforms it inputs into outputs that are performed by mechanism under the control condition.

- The second step is the 'Cost Analysis', all concerned resources and costs of the organisation from several sources were examined and categorised into seven cost elements i.e. Manpower, Supplies, Rental Equipment, Rental Heavy Equipment, Facilities and Miscellaneous Expenses.
- 'Develop Cost Flow Model' is the third step where the structure of the estimation system is created. Together with this the cost objects of the case project are also analysed based on the consideration of organisational structure and WBS of the project. These analysis were validated by discussion and brainstorming with the cross-functional managers. However, this high level conceptual model not only shows how overhead cost that was captured in the previous step can be traced to activities, but also displays how activity costs will be then traced to cost objects.
- 'Cost Information Gathering' this step can be done in parallel with the first and the second step by gathering all of the cost information that can captured from various sources those major sources are such as the Accounting Records of the project, the General Administration Department and Human Resource Department.
- 'Gathering Resource Driver Information' is the next step to collect the resource driver information to be used as an allocation base in distributing all of those seven categories of costs into the functional elements of the organisational structure. By using the percentage of effort time that was captured from the gathering form and interviewing the concerned personnel, all of those overhead cost were traced into each of functional element of the project.
- 'Gathering Activity Driver Information' is the step that uses the concept of Two-Stage Cost Allocation system of ABC. The first stage is to trace cost to activity. The costs from the previous step were allocated into the entire activity that analysed at the first step. This means that not only the operation costs that were traced into its related activity cost pools, but also the managerial and supporting costs. Then in the second stage the capturing of activity driver volume was performed by detailed studying of erection drawing, lifting procedure and all concerned documents of the installation works. The total captured activity driver volume in each of it activity cost pool was used to calculate the activity cost driver or overhead rate which was used as the allocation base in tracing activity cost into cost object.

- ‘Generate Costing Report’ is the seventh step that proposes three types of report to be used to support the project management not only in the commercial decision making, but also identifying opportunities in process improvement
- ‘Model Evaluation’ is the last step in this methodology to evaluate the appropriateness of the ABC method in applying to estimate the installation cost of construction project. By using cost variance and percent of cost variance to analyse the distortion occurred by the traditional system that represented as a percent difference from ABC. Two criteria are defined as quantitative and qualitative criteria to make it clearer in summarising the results.

The study found that the operation function of the case project consisted of 5 macro activities and its 21 micro activities, whereas the supporting function comprised 5 macro activities and its 11 micro activities. The captured overhead costs were allocated to the entire activities and the 20 cost objects or work packages by its corresponding 25 activity cost drivers.

Having compared the cost per cost object under the traditional and the ABC estimating method to evaluate the extent of cost distortion caused by the traditional method, it was quantitatively found that 18 out of all packages or 90% were significantly deviated, while the qualitative evidence illustrated that 13 out of all packages or 65% were distorted by more than 20% of cost variance.

This means that the ABC approach could not only be usefully applied to estimate the installation cost of the mechanical work, but it also provided more reasonable and clearer cost information than the traditional system. Nevertheless, the ABC requires far more time and resource than the existing system in terms of its information acquisition and investment.

Therefore, in order to enhance the effective use of the two systems where possible, the traditional system should be considered as the estimation method when time is the constraining factor, while the ABC should be required when accuracy is the limiting factor within the maximum 20% of cost variance.

5.2 Recommendation

The following points should be considered for the further study of ABC system:

- The goals, scope and objectives of the study should be clearly and precisely defined. Since throughout the study many decisions will be based on this

definition, so, the more clearly and precisely the objective can be defined the more concentrated the study can be.

- Top management commitment is also one of the most essential part. Since if the costing project is a new costing methodology, top management should be committed and encouraged their costing project team by providing a strong support and facilitating them until the system is successfully implemented.
- To be useful for the decision-maker, the information and the decision criteria must be consistent. Since in the shortsighted viewpoint of cost precision, time-based depreciation is preferred. On the other hand, from the viewpoint that to be useful for the decision-maker, volume-based depreciation is preferred.
- The use of Pareto's analysis (80/20 rule) should be critically evaluated in obtaining significant activities to focus the planning and control resources in cost reduction or process improvement.
- In order to successfully develop and implement the ABC process, it needs a cross-functional integration and cooperation among various department of the organisation. So, a clear set of training or education program needs to be established.
- In developing an ABC model for the first time, it should be very useful to select a specialised software package to support the project. This is because it can reduce time related with the development and enhance the quality of outcome reports.
- The information technology (IT) and information system strategy can play a key role in the future development and implementation of ABC. This is because it can enhance and essential in updating, collecting and verifying a massive data or information to be used for the model.
- The actual costs of the case project should be further used in comparing with the costs estimated by the old and ABC system.
- Since the implementation of ABC seems to be more costly than the traditional costing system, therefore, a company should analyse cost-benefit of ABC before committing to its implementation.

References

- Atkinson, A.A., and others. 1995. Management Accounting. New Jersey: Prentice-Hall.
- Brimson, James A. 1991. Activity Accounting: An Activity-Based Costing Approach. New York: John Wiley & Sons.
- Chadwick, Leslie. 1993. Management Accounting. London: Routledge.
- Commonwealth Department of Employment, Final report. 2000. A Study to Develop a Costing Methodology for the Australian Higher Education Sector.
<http://www.detya.gov.au/highered/otherpub/costing/html>.
- Cooper R., Kaplan R.S. 1991. The Design of Cost Management Systems: Text, Cases, and Readings. New Jersey: Prentice-Hall.
- Department of Defense of US.1993. Corporate Information management (CIM) Improvement Methodology for DOD Function Managers.
<http://www.dtic.mil/c3i/bprcd/3001.htm>
- Dilley, S.C., and others. March 1997. Journal of Accountancy. The Tax benefits of ABC: Companies with the right production and cost characteristics can achieve considerable savings.
- Duangdee Angsamaporn. 1999. Master of Industrial Engineering Thesis (in Thai). Manufacturing Cost System Improvement In A Curtain Wall Factory By The Activity-Based Costing System. Chulalongkorn University.
- Haldane, Glenn. May 1998. Accountancy International Ed. “Fixed Overheads: How should you allocate costs to products?”

- Innes, J. and Mitchell, F. Dec 1991. ABC: A Survey of CIMA Members. Management Accounting.
- Institute of Management Accounting. 1993. Practices and Technique: Implement Activity-Based Costing. <http://www.rutgers.edu/Accounting/raw/ima/imabc.htm>.
- Meredith, J.R. and Mantel, S.J. 1995. Project Management: A Managerial Approach. 3rd ed. New York: John Wiley & Son.
- Morrow M., ed. 1992. Activity-Based Management: New Approaches To Measuring Performance And Managing Costs. Great Britain: Woodhead-Faulkner.
- Nujarin Chimpoy. 1999. MBA Thesis (in Thai). ABC for Operating Budget of Electricity Generating Authority of Thailand Case Study: Mae Moh Power Plant Lampang. Chiangmai University.
- O'guin, M.C. 1991. The Complete Guide To Activity Based Costing. New Jersey: Prentice Hall.
- Olomolaiye, P.O., and others. 1998. Construction Productivity Management. Singapore: Addison Wesley Longman.
- Paramate Suwanpradit. 2000. Master of Engineering Management Thesis. Activity-Based Costing of Project Management in the Construction of a 2,000 m³ LPG Spherical Tank Project. Chulalongkorn University and University of Warwick.
- Supakit Chantaravisutilert. 1999. Master of Engineering Management Thesis. Comparative Study of Activity-Based Costing and Conventional Costing for Job Order for Manufacturing of a Plastics Injection Mold. Chulalongkorn University and University of Warwick.
- Turney, P.B.B. 1996. Activity-Based Costing: The Performance Breakthrough. London: Kogan Page.



Appendices

สถาบันวิทยบริการ
จุฬาลงกรณ์มหาวิทยาลัย

Appendix A

Project Erection Schedule

In this appendix, the following Figure A-1 is comprised 7 sheets of Mechanical Erection Schedule for the Simple Cycle Power Plant Construction Project (SCCPCP) of Ratchaburi Combined Cycle Power Plant Block I.



สถาบันวิทยบริการ
จุฬาลงกรณ์มหาวิทยาลัย

RATCHABURI COMBINED CYCLE POWER PLANT GT-101 MECHANICAL ERECTION SCHEDULE

ID	Task Name	Duration	Start	Finish	1998											
					Jun '98	Jul '98	Aug '98	Sep '98	Oct '98	Nov '98	Dec '98	Jan '99	Feb '99			
1	GAS TURBINE UNIT 101	158d	1/6/98	6/1/99	[Gantt bar spanning from Jun '98 to Jan '99]											
2	Gas Turbine	135d	1/6/98	4/12/98	[Gantt bar spanning from Jun '98 to Dec '98]											
3	Embedded Part & Anchor Bolt	10d	1/6/98	12/6/98	[Gantt bar spanning from Jun '98 to Jun '98]											
4	Leveling Plate	10d	13/6/98	28/6/98	[Gantt bar spanning from Jun '98 to Jun '98]											
5	Shim Contact Check	7d	28/6/98	7/7/98	[Gantt bar spanning from Jun '98 to Jun '98]											
6	On Base & Centering	3d	5/7/98	8/7/98	[Gantt bar spanning from Jun '98 to Jun '98]											
7	Leg drop check	4d	11/7/98	16/7/98	[Gantt bar spanning from Jun '98 to Jun '98]											
8	Install Load Coupling	5d	17/7/98	23/7/98	[Gantt bar spanning from Jun '98 to Jun '98]											
9	Pre - Alignment	2d	26/10/98	27/10/98	[Gantt bar spanning from Oct '98 to Oct '98]											
10	Assembly Center Key & Welding	7d	28/10/98	5/11/98	[Gantt bar spanning from Oct '98 to Oct '98]											
11	Remove of Transport Beam	2d	28/10/98	29/10/98	[Gantt bar spanning from Oct '98 to Oct '98]											
12	Final Alignment & connection to Gen	5d	30/11/98	4/12/98	[Gantt bar spanning from Oct '98 to Oct '98]											
13	Install DLN Combustors	36d	15/10/98	3/12/98	[Gantt bar spanning from Oct '98 to Oct '98]											
14	Install Outer casing (ML 0719)	7d	15/10/98	23/10/98	[Gantt bar spanning from Oct '98 to Oct '98]											
15	Install Flow Sleeve (ML 0709)	5d	26/10/98	30/10/98	[Gantt bar spanning from Oct '98 to Oct '98]											
16	Install Liner (ML 0703)	5d	2/11/98	6/11/98	[Gantt bar spanning from Oct '98 to Oct '98]											
17	Install Cap & Liner Assy (ML 0722)	5d	9/11/98	13/11/98	[Gantt bar spanning from Oct '98 to Oct '98]											
18	Install Fuel Nozzle (ML 0512)	7d	16/11/98	24/11/98	[Gantt bar spanning from Oct '98 to Oct '98]											
19	Install Piping to Fuel Nozzle	7d	25/11/98	3/12/98	[Gantt bar spanning from Oct '98 to Oct '98]											
20	Turbine & Exhaust Duct Enclosures	55d	1/10/98	16/12/98	[Gantt bar spanning from Oct '98 to Oct '98]											

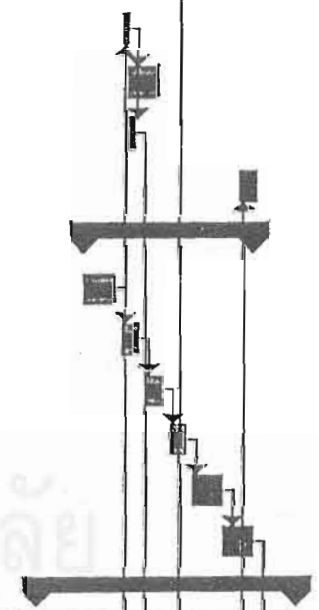

RATCHABURI COMBINED CYCLE POWER PLANT GT-101 MECHANICAL ERECTION SCHEDULE

ID	Task Name	Duration	Start	Finish	1998											
					Jun '98	Jul '98	Aug '98	Sep '98	Oct '98	Nov '98	Dec '98	Jan '99	Feb '99			
21	Install Turbine Enclosure Walls (ML 1634)	10d	1/10/98	14/10/98												
22	Install GT. Walkways (ML 1645)	10d	15/10/98	28/10/98												
23	Install Turbine Enclosure Roof (ML 1634)	5d	3/12/98	9/12/98												
24	Vent Fan Roof, T/B Enclosure	2d	10/12/98	11/12/98												
25	Install Exhaust Enclosure (A102)	14d	9/11/98	26/11/98												
26	Install Cooling Air Module (ML 1643)	5d	10/12/98	16/12/98												
27	Exhaust Outer Duct work	28d	20/11/98	29/12/98												
28	GT. Comp. Exh. Outer Duct Work	7d	20/11/98	30/11/98												
29	LF/AA Modul Exh. Vent Duct Work	7d	1/12/98	9/12/98												
30	Acc. Module Exh. Outer Duct Work	7d	10/12/98	18/12/98												
31	Load Comp. Exhaust Outer Duct Work	7d	21/12/98	29/12/98												
32	Walkways, Handrall, Ladder	17d	15/12/98	6/1/99												
33	Around LF/AA Modul & Acc. Module	5d	15/12/98	21/12/98												
34	Around Gas Turbine	10d	15/12/98	28/12/98												
35	Around Generator	7d	29/12/98	6/1/99												
36	On base Piplng	136d	10/6/98	16/12/98												
37	Cooling & Sealing Air Piping (ML 0909)	30d	10/6/98	21/7/98												
38	Atomizing Air Piping (ML 0965)	5d	22/6/98	26/6/98												
39	Fuel Gas Piping (ML 0962)	30d	29/6/98	7/8/98												
40	Purge Air Piping (ML 0918)	5d	10/8/98	14/8/98												

RATCHABURI COMBINED CYCLE POWER PLANT GT-101 MECHANICAL ERECTION SCHEDULE

ID	Task Name	Duration	Start	Finish	1998								Jan '99	Feb '99
					Jun '98	Jul '98	Aug '98	Sep '98	Oct '98	Nov '98	Dec '98			
41	Water Injection Piping (ML0968)	5d	17/8/98	21/8/98										
42	Air Extraction Piping (ML 0924)	7d	22/6/98	30/6/98										
43	False Start Drain Piping (ML 0920)	7d	30/10/98	9/11/98										
44	Cooling Water Piping (ML 0915)	8d	1/7/98	10/7/98										
45	Water Wash Piping (ML 0953)	5d	24/9/98	30/9/98										
46	Fire Protection Piping Exh. Compt. (ML 0995)	3d	14/12/98	16/12/98										
47	Lube Oil #1 Brearing Piping (ML 0905)	7d	22/6/98	30/6/98										
48	Lube Oil Piping (ML 0906)	5d	1/7/98	7/7/98										
49	Lube Oil #2 Brearing Piping (ML 0907)	7d	15/9/98	23/9/98										
50	Inlet Plenum Drain Piping (ML 0979)	2d	24/9/98	25/9/98										
51	Exhaust Plenum Drain Piping (ML 0976)	12d	28/9/98	13/10/98										
52	Cooling Air I/h Exh. Frame Piping	2d	14/10/98	15/10/98										
53	On Base Interconnecting Piping (ML 0969)	103d	29/6/98	18/11/98										
54	Lube Oil Intercon Piping (ML 0969)	5d	1/7/98	7/7/98										
55	Atomizing Air Intercon Piping	5d	29/6/98	3/7/98										
56	Control Oil Intercon Piping	3d	2/10/98	6/10/98										
57	Cooling Water intercon Piping	3d	1/10/98	5/10/98										
58	Water Injection Intercon Piping	3d	9/10/98	13/10/98										
59	Liquid Fuel Purge Intercon Piping	5d	14/10/98	20/10/98										
60	Liquid Fuel Intercon Piping	5d	21/10/98	27/10/98										

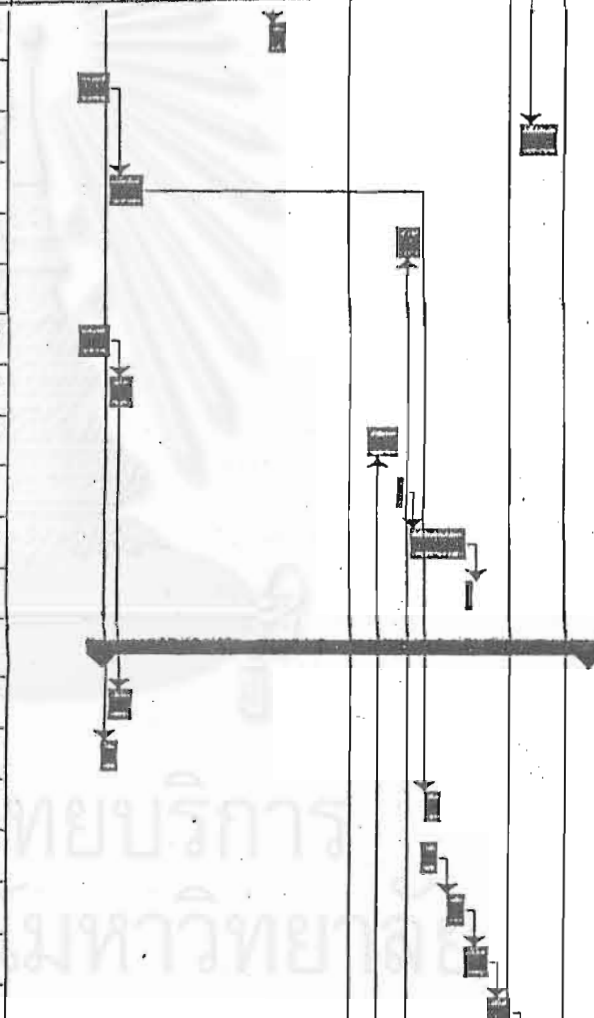

RATCHABURI COMBINED CYCLE POWER PLANT GT-101 MECHANICAL ERECTION SCHEDULE

ID	Task Name	Duration	Start	Finish	1998											
					Jun '98	Jul '98	Aug '98	Sep '98	Oct '98	Nov '98	Dec '98	Jan '99	Feb '99			
61	False Start Drain	5d	28/10/98	3/11/98												
62	Cooling & Sealing Air Tubing Intercon Piping	5d	4/11/98	10/11/98												
63	Fire Protection intercon Piping	3d	11/11/98	13/11/98												
64	Cooling Air u/h Frame Piping	3d	16/11/98	18/11/98												
65	Lube Oil Flush (For Gas Turbine)	38d	12/10/98	2/12/98												
66	Install Flush Piping (ML A125)	7d	12/10/98	20/10/98												
67	Modify Lube Oil Tank & Piping	5d	22/10/98	28/10/98												
68	Fill Oil	2d	29/10/98	30/10/98												
69	Flush Bearing & Seal Oil Lines	20d	2/11/98	27/11/98												
70	Flush Hydraulic Lines	3d	30/11/98	2/12/98												
71	Generator	92d	3/8/98	8/12/98												
72	Embed Part & Anchor Bolt	14d	3/8/98	20/8/98												
73	Chif Concret & Set Mortar	10d	21/8/98	3/9/98												
74	Leveling Plate	5d	4/9/98	10/9/98												
75	On Base	1d	11/9/98	11/9/98												
76	Cleaning of Stator Frame Surface	3d	14/9/98	16/9/98												
77	Contract Check of Bearing to End Shield	3d	17/9/98	21/9/98												
78	Temporary Alignment for ST, FM	2d	22/9/98	23/9/98												
79	Preparation of Install Rotor	5d	24/9/98	30/9/98												
80	Assembly of Bottom End Shield	2d	1/10/98	2/10/98												

RATCHABURI COMBINED CYCLE POWER PLANT GT-101 MECHANICAL ERECTION SCHEDULE

ID	Task Name	Duration	Start	Finish	1998							Jan '99	Feb '99
					Jun '98	Jul '98	Aug '98	Sep '98	Oct '98	Nov '98	Dec '98		
81	Assembly of Bottom Bearing	1d	5/10/98	5/10/98									
82	Install Nozzle Ring	1d	6/10/98	6/10/98									
83	Install Bottom Fan Guide	1d	7/10/98	7/10/98									
84	Install Fan Blade	2d	8/10/98	9/10/98									
85	Install Inside Bottom Oil Shields	2d	12/10/98	13/10/98									
86	Install Upper End Shields	2d	14/10/98	15/10/98									
87	Install of collector Base and Stub Shaft	2d	16/10/98	19/10/98									
88	Run Out Check of Rotor	1d	20/10/98	20/10/98									
89	Turbine Gen Alignment	3d	21/10/98	23/10/98									
90	Connection of Turbine-Gen Coupling	2d	26/10/98	27/10/98									
91	Assembly Around Collector Base	5d	28/10/98	3/11/98									
92	Hydro Test for H2 Cooler	5d	8/10/98	14/10/98									
93	Assembly of H2 Cooler	5d	15/10/98	21/10/98									
94	Assembly of Seal Case	2d	30/11/98	1/12/98									
95	Assembly Bearing	3d	2/12/98	4/12/98									
96	Generator Leak Test	2d	7/12/98	8/12/98									
97	Exciter	51d	17/8/98	26/10/98									
98	Anchor Bolt	2d	17/8/98	18/8/98									
99	Sole plate Setting	3d	5/10/98	7/10/98									
100	On base	1d	8/10/98	8/10/98									

RATCHABURI COMBINED CYCLE POWER PLANT GT-101 MECHANICAL ERECTION SCHEDULE

ID	Task Name	Duration	Start	Finish	1998											
					Jun '98	Jul '98	Aug '98	Sep '98	Oct '98	Nov '98	Dec '98	Jan '99	Feb '99			
101	Alignment	1d	26/10/98	26/10/98												
102	Turning Gear	51d	17/8/98	26/10/98												
103	Anchor Bolt	1d	17/8/98	17/8/98												
104	Sole plate Setting	3d	18/8/98	20/8/98												
105	On base	1d	28/9/98	28/9/98												
106	Alignment & Coupling to Generator	1d	26/10/98	26/10/98												
107	Generator Lube Oil System	67d	1/10/98	1/1/99												
108	Generator Lube Oil Piping (REOL Supply)	20d	1/10/98	28/10/98												
109	Chemical Cleaning & Hydro Test	5d	29/10/98	4/11/98												
110	Flushing	30d	23/11/98	1/1/99												
111	Install Air Detraining Section	2d	5/10/98	6/10/98												
112	Install Seal Drain Enlargement Section	2d	5/10/98	6/10/98												
113	Generator Seal Oil System	45d	28/9/98	27/11/98												
114	Seal Oil Skid (Hitachi Supply)	3d	28/9/98	30/9/98												
115	Generator Seal Oil Piping (REOL Supply)	30d	5/10/98	13/11/98												
116	Flushing	20d	2/11/98	27/11/98												
117	Compress Gas	22d	1/12/98	30/12/98												
118	Install co2 Piping	15d	1/12/98	21/12/98												
119	Install H2 Piping	15d	10/12/98	30/12/98												
120	CT. Exhaust Diffuser (ML-0706)	96d	17/8/98	28/12/98												

RATCHABURI COMBINED CYCLE POWER PLANT GT-101 MECHANICAL ERECTION SCHEDULE

ID	Task Name	Duration	Start	Finish	1998											
					Jun '98	Jul '98	Aug '98	Sep '98	Oct '98	Nov '98	Dec '98	Jan '99	Feb '99			
121	Anchor Bolt	2d	17/8/98	18/8/98												
122	Pre-Assembly	5d	1/9/98	7/9/98												
123	Install & Assembly	3d	10/9/98	14/9/98												
124	Insulation & Lagging	10d	15/12/98	28/12/98												
125	Air Inlet Plenum System	12d	10/9/98	25/9/98												
126	Support	3d	10/9/98	14/9/98												
127	Install Inlet Plenum Casing (ML-1612)	4d	15/9/98	18/9/98												
128	Install Inlet Plenum Casing (ML-1612)	3d	21/9/98	23/9/98												
129	Install Lower & Upper Cone	2d	24/9/98	25/9/98												
130	Expansion Joint	2d	24/9/98	25/9/98												
131	Inlet Plenum Drain ppg. (ML 0979)	2d	21/9/98	22/9/98												
132	Accessory Module (ML A160)	5d	15/10/98	21/10/98												
133	LF/AA Module (ML A 162)	5d	15/10/98	21/10/98												
134	Co2 Skid (Fire Protection)	4d	5/10/98	8/10/98												
135	Water Injection Skid	2d	2/9/98	3/9/98												
136	Water Wash Skid (ML E025)	2d	4/9/98	7/9/98												
137	Seal Oil Skid	3d	1/10/98	5/10/98												
138	Fuel Gas Heater	3d	15/12/98	17/12/98												
139	Fuel Gas Separator Drain Tank	3d	18/12/98	22/12/98												
140	GT. Aux Cooling Water Pump	3d	23/12/98	26/12/98												

Appendix B

Examples of Costing Reports

The examples of costing reports for the case project that relevant with the following three types of reports are summarised as below.

- ‘Activity cost report’ that summarises cost per activity as regarding to Table B-1 to B-3.
- ‘Cost per cost objects report’ that evaluates cost per cost object as shown in Table B-4. In addition, the project’s six main elements of costs in according to Table 3-6 are illustrated in Figure B-1. Moreover, the quantitative and qualitative results of the distortion of traditional as percentage difference from ABC system are shown in Figure B-2 and B-3 respectively.
- ‘Activity unit cost and benchmarking report’ that examines each of the activity unit cost of the case project in comparison with two other unit costs i.e. the ‘Average unit cost’ and the ‘Best practice unit cost’. This is as summarised in Table B-5. However, there is some limitation of this report. For example of the ‘Benchmarking Report’, the ‘Average Industrial Unit Cost’ and the ‘Best Practice Unit Cost’ are treated as confidential data of the private company so in comparison, the prices were used instead of costs. Moreover, these prices are lower than those cost of the case organisation from the reason that company’s business strategy is the ‘Cost leadership’ with the capability to effectively allocate resources among many projects that are located on the nearby area. Furthermore, the case organisation is the state enterprise with the strategy of the ‘Customer Focus’ that concentration on quality and reliability.

Ranking by	Activity		Activity Cost		Category
Macro Activity	NODE	Description	Baht	%of Total	
1	A4	Lifting-On-Base	฿3,222,105	25.27%	Operational
	A41	Lifting/Hauling	฿967,854	7.59%	
	A42	Setting&Levelling	฿1,017,495	7.98%	
	A43	Inserting/Assembling	฿924,784	7.25%	
	A44	Aligning&Coupling	฿288,176	2.26%	
	A45	Key Fixing	฿23,796	0.19%	
2	A2	Equipment Receiving	฿1,923,897	15.03%	Supporting
	A21	Equipment Receiving	฿95,195	0.75%	
	A22	Unloading/Warehousing	฿673,364	5.28%	
	A23	On-Site Transporting	฿961,948	7.54%	
	A24	Unpacking&preparing	฿192,390	1.51%	
3	A5	System Piping	฿1,794,839	14.03%	Operational
	A51	Support Installing	฿244,339	1.92%	
	A52	Fitting-Up/Centering	฿854,275	6.70%	
	A53	Welding/Bolting/Sealing	฿554,376	4.35%	
	A54	Non-Destructive Testing	฿58,149	0.46%	
	A55	Leak/Pressure Testing	฿83,701	0.66%	
4	A1	Advance Planning	฿1,204,137	9.44%	Managerial
	A11	WBS	฿186,621	1.42%	
	A12	Milestone Laying-Out	฿120,414	0.94%	
	A13	Organisation Chart	฿60,207	0.47%	
	A14	Control Network	฿186,621	1.42%	
	A15	Base-Line Input Data	฿36,124	0.28%	
	A16	Monitoring Proj. Status	฿240,827	1.89%	
	A17	Evaluating Performance	฿365,324	3.02%	
5	WS	Workshop	฿966,750	7.58%	Supporting
6	ADM	Administration	฿951,796	7.46%	Supporting
7	A6	System Cleaning	฿932,760	7.32%	Operational
	A61	Flush-Pipes Installing	฿63,258	0.50%	
	A62	Initial Filling	฿84,310	0.66%	
	A63	Flushing/Blowing-Down	฿674,926	5.29%	
	A64	Final Restoration	฿110,266	0.86%	
8	OVHC	Store Crane	฿759,241	5.95%	Supporting
9	A7	Painting& Insulating	฿547,582	4.29%	Operational
	A71	Surface Preparing	฿111,920	0.88%	
	A72	Preventive Coating	฿271,368	2.13%	
	A73	Insulating&Lagging	฿139,250	1.09%	
	A74	Labelling/Tagging	฿25,025	0.20%	
10	A3	Foundation Preparing	฿443,225	3.48%	Operational
	A31	Interface Verifying	฿67,349	0.53%	
	A32	Embedments Installing	฿164,564	1.29%	
	A33	Setting&Grouting	฿211,312	1.66%	
	Total Overhead Costs		฿12,750,630	100.00%	

Table B-2: Activity cost report by identifying activities, its activity cost drivers and overhead rates.

Source: Reprinted from Table 3-21.

Activity		Activity Cost	Activity Cost Drivers			Overhead Rates
NODE	Description		Description	Total Volume	Baht/Unit	
A1	Advance Planning	฿1,204,137				
A11	WBS	฿180,621	# Work Package	20 Pckg	฿9,031.03	
A12	Milestone Laying-Out	฿120,414	# Work Package	20 Pckg	฿6,020.69	
A13	Organisation Chart	฿60,207	# Work Package	20 Pckg	฿3,010.34	
A14	Control Network	฿180,621	# Work Package	20 Pckg	฿9,031.03	
A15	Base-Line Input Data	฿36,124	# Work Package	20 Pckg	฿1,806.21	
A16	Monitoring Proj. Status	฿240,827	# Progress Report	320 Rprt	฿752.59	
A17	Evaluating Performance	฿385,324	# Evaluation Report	320 Rprt	฿1,204.14	
A2	Equipment Receiving	฿1,923,897				
A21	Equipment Receiving	฿96,195	# Man-Days	316 Md	฿304.41	
A22	Unloading/Warehousing	฿673,364	# Man-Days	790 Md	฿852.36	
A23	On-Site Transporting	฿961,948	# Man-Days	2,054 Md	฿468.33	
A24	Unpacking&preparing	฿192,390	# Man-Days	632 Md	฿304.41	
A3	Foundation Preparing	฿443,225				
A31	Interface Verifying	฿67,349	# Verifying Areas	3,215 m2	฿20.95	
A32	Embedments Installing	฿164,564	# Installing Areas	636 m2	฿258.82	
A33	Setting&Grouting	฿211,312	# Grouting Areas	298 m2	฿708.53	
A4	Lifting On-Base	฿3,222,105				
A41	Lifting/Hauling	฿967,854	# Equip. Weights	1,175 T	฿823.78	
A42	Setting&Levelling	฿1,017,495	# Equip. Weights	1,175 T	฿866.03	
A43	Inserting/Assembling	฿924,784	# Equip. Weights	917 T	฿1,008.29	
A44	Aligning&Coupling	฿288,176	# Man-Days	145 Md	฿1,987.42	
A45	Key Fixing	฿23,796	# Man-Days	46 Md	฿517.30	
A5	System Piping	฿1,794,839				
A51	Support Installing	฿244,339	# Supporting	1,366 Sets	฿178.94	
A52	Fitting-Up/Centering	฿854,275	# Welding Joints	2,763 FW	฿309.18	
A53	Welding/Bolting/Sealing	฿554,376	# Welding Joints	2,763 FW	฿200.64	
A54	Non-Destructive Testing	฿58,149	# Welding Joints	1,293 FW	฿44.97	
A55	Leak/Pressure Testing	฿83,701	# Testing Duration	21 d	฿3,985.76	
A6	System Cleaning	฿932,760				
A61	Flush-Pipes Installing	฿63,258	# Installing Times	141 Md	฿448.64	
A62	Initial Filling	฿84,310	# Filling Times	111 Md	฿762.98	
A63	Flushing/Blowing-Down	฿674,926	# Flushing Times	903 Md	฿747.84	
A64	Final Restoration	฿110,266	# Restoring Times	189 Md	฿583.42	
A7	Painting& Insulating	฿547,562				
A71	Surface Preparing	฿111,920	# Preparing Areas	1,656 m2	฿67.58	
A72	Preventive Coating	฿271,366	# Coating Areas	1,656 m2	฿163.87	
A73	Insulating&Lagging	฿139,250	# Insulating Areas	266 m2	฿524.43	
A74	Labelling/Tagging	฿25,025	# Work Package	20 Pckg	฿1,251.25	
W/S	Workshop	฿966,750	# Man-Days	1,232 Md	฿784.45	
OVHC	Store Crane	฿759,241	# Man-Days	2,054 Md	฿369.64	
ADM	Administration	฿95,1796	# Work Package	20 Pckg	฿47,589.81	
Total Overhead Costs		฿12,750,630				

Table B-3: Activi-Based Costs Estimation Report for Cost Object No. 0411(Alignment Check).

Source: Reprinted from Table 3-23.

Activity		Activity Cost Drivers			Overhead Rates	Ovehead Costs	Calculation Details
NODE	Description	Description	Volume	Baht/Unit	Baht		
A1 Advance Planning							
A11	WBS	# Work Package	1 Pckg	฿9,031.03	฿9,031	=1.0* B9,031.03	
A12	Milestone Laying-Out	# Work Package	1 Pckg	฿6,020.69	฿6,021	=1.0* B6,020.69	
A13	Organisation Chart	# Work Package	1 Pckg	฿3,010.34	฿3,010	=1.0* B3,010.34	
A14	Control Network	# Work Package	1 Pckg	฿9,031.03	฿9,031	=1.0* B9,031.03	
A15	Base-Line Input Data	# Work Package	1 Pckg	฿1,806.21	฿1,806	=1.0* B1,806.2	
A16	Monitoring Proj. Status	# Progress Report	16 Rprt	฿752.59	฿12,041	=16.0* B9752.59	
A17	Evaluating Performance	# Evaluation Report	16 Rprt	฿1,204.14	฿19,266	=16.0* B1,204.14	
A2 Equipment Receiving							
A21	Equipment Receiving	# Man-Days	63 Md	฿304.41	฿19,239	=63.0* B304.41	
A22	Unloading/Warehousing	# Man-Days	158 Md	฿852.36	฿134,673	=158.0* B852.36	
A23	On-Site Transporting	# Man-Days	411 Md	฿468.33	฿192,390	=411* B468.33	
A24	Unpacking&preparing	# Man-Days	126 Md	฿304.41	฿38,478	=126.0* B304.41	
A3 Foundation Preparing							
A31	Interface Verifying	# Verifying Areas	655 m2	฿20.95	฿13,715	=655* B20.95	
A32	Embedments Installing	# Installing Areas	164 m2	฿258.82	฿42,362	=164* B258.82	
A33	Setting&Grouting	# Grouting Areas	44 m2	฿708.53	฿30,924	=44* B708.53	
A4 Lifting On-Base							
A41	Lifting/Hauling	# Equip. Weights	289 T	฿823.78	฿237,772	=289* B823.78	
A42	Setting&Levelling	# Equip. Weights	289 T	฿866.03	฿249,967	=289* B866.03	
A43	Inserting/Assembling	# Equip. Weights	289 T	฿1,008.29	฿291,029	=289* B1,008.29	
A44	Aligning&Coupling	# Man-Days	35 Md	฿1,987.42	฿69,560	=35* B1,987.42	
A45	Key Fixing	# Man-Days	9 Md	฿517.30	฿4,656	=9* B517.30	
A5 System Piping							
A51	Support Installing	# Supporting	0 Sets	฿178.94	฿0	n/a	
A52	Fitting-Up/Centering	# Welding Joints	0 FW	฿309.18	฿0	n/a	
A53	Welding/Boiting/Sealing	# Welding Joints	0 FW	฿200.64	฿0	n/a	
A54	Non-Destructive Testing	# Welding Joints	0 FW	฿44.97	฿0	n/a	
A55	Leak/Pressure Testing	# Testing Duration	0 d	฿3,985.76	฿0	n/a	
A6 System Cleaning							
A61	Flush-Pipes Installing	# Installing Times	0 Md	฿448.64	฿0	n/a	
A62	Initial Filling	# Filling Times	0 Md	฿762.98	฿0	n/a	
A63	Flushing/Blowing-Down	# Flushing Times	0 Md	฿747.84	฿0	n/a	
A64	Final Restoration	# Restoring Times	0 Md	฿583.42	฿0	n/a	
A7 Painting& Insulating							
A71	Surface Preparing	# Preparing Areas	352 m2	฿67.58	฿23,799	=352* B67.58	
A72	Preventive Coating	# Coating Areas	352 m2	฿163.87	฿57,703	=352* B163.87	
A73	Insulating&Lagging	# Insulating Areas	0 m2	฿524.43	฿0	n/a	
A74	Labelling/Tagging	# Work Package	1 Pckg	฿1,251.25	฿1,251	=1* B1,251.25	
WS	Workshop	# Man-Days	407 Md	฿784.45	฿319,028	=407* B784.45	
OVHC	Store Crane	# Man-Days	514 Md	฿369.64	฿189,810	=514* B369.64	
ADM	Administration	# Work Package	1 Pckg	฿47,589.81	฿47,590	=1* B47,589.81	
Total Overhead Costs						฿2,024,151	
Number of Packages						1	
Cost per Unit						฿2,024,151	=B2,024,251/1

According to Table 3-16, the following is the proportion of the entire cost elements of the case project.

Total Manpower Cost	Total Supplies Cost	Total Rental Cost	Heavy Equipment	Total Facility Cost	Total miscellaneous expenses	Grand Total Operational Cost
(Baht)	(Baht)	(Baht)	(Baht)	(Baht)	(Baht)	(Baht)
฿7,340,294	฿740,000	฿168,030	฿3,245,110	฿21,714	฿1,235,483	฿12,750,630
57.57%	5.80%	1.32%	25.45%	0.17%	9.69%	100.00%

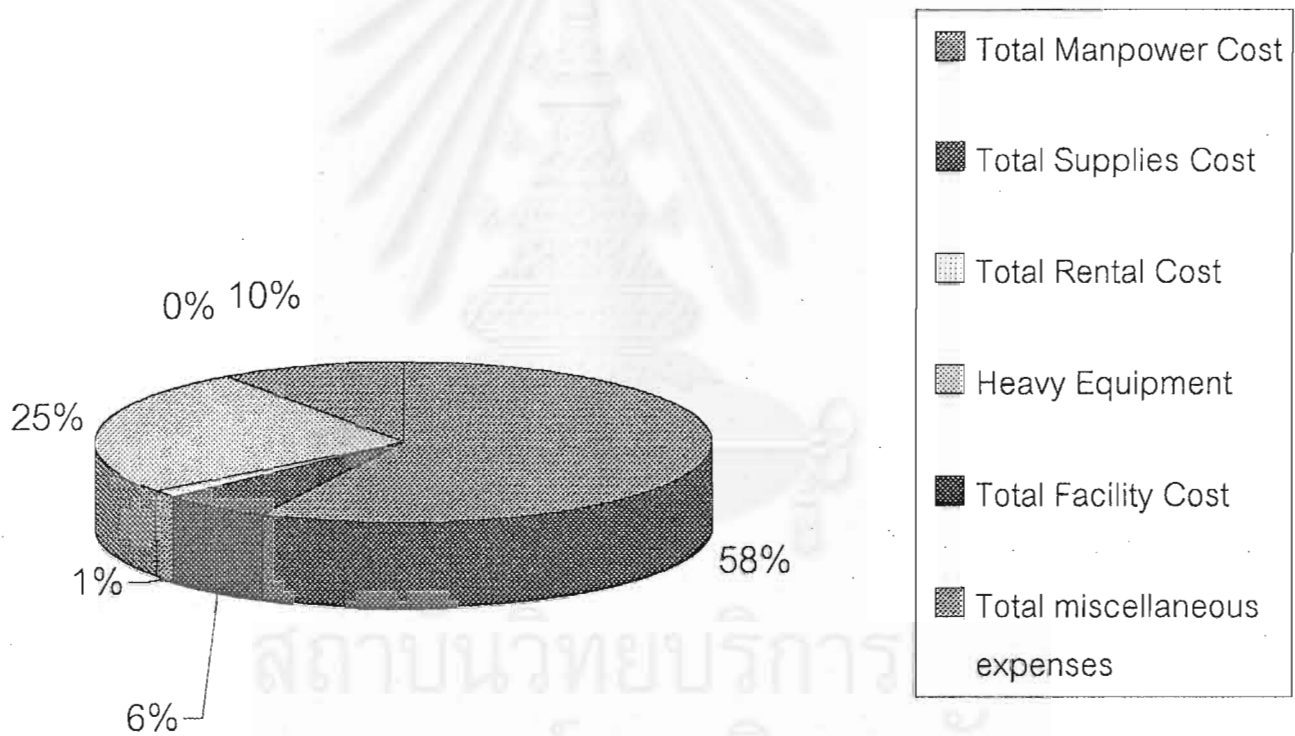

Figure B-1: Proportion of the entire cost elements of the case project.

Table B-4: Cost per Cost Object Report.

Source: Reprinted from Table 3-24.

Activity		Activity Cost Driver Values for each of Cost Object																						
ODE	Description	C/D Rates	Gas Turbine System											Generator Sys.			Common Facilities					Total		
		Baht/Unit	0411	0417	0422	0424	0425	0442	0481	0462	0469	0471	0477	0700	0440-1	0440-2	0440-3	0416	0420	0421	0426	0436	Volume	Unit
A1	Advance Planning																							
A11	WBS	89,031.03	1	1	1	1	1	1	1	1	1	1	1	1	1	1	1	1	1	1	1	1	20	Pckg
A12	Milestone Laying-Out	86,020.69	1	1	1	1	1	1	1	1	1	1	1	1	1	1	1	1	1	1	1	1	20	Pckg
A13	Organisation Chart	83,010.34	1	1	1	1	1	1	1	1	1	1	1	1	1	1	1	1	1	1	1	1	20	Pckg
A14	Control Network	89,031.03	1	1	1	1	1	1	1	1	1	1	1	1	1	1	1	1	1	1	1	1	20	Pckg
A15	Base-Line Input Data	81,806.21	1	1	1	1	1	1	1	1	1	1	1	1	1	1	1	1	1	1	1	1	20	Pckg
A16	Monitoring Proj. Status	8752.59	16	16	16	16	16	16	16	16	16	16	16	16	16	16	16	16	16	16	16	16	320	Rprt
A17	Evaluating Performance	81,204.14	16	16	16	16	16	16	16	16	16	16	16	16	16	16	16	16	16	16	16	16	320	Rprt
A2	Equipment Receiving																							
A21	Equipment Receiving	8304.41	83	9	16	16	6	6	6	6	32	3	3	57	6	6	38	6	3	6	19	316	Md	
A22	Unloading/Warehousing	8852.36	158	24	40	40	16	16	16	16	79	8	8	142	16	16	95	16	8	16	47	790	Md	
A23	On-Site Transporting	8468.33	411	62	103	103	41	41	41	41	205	21	21	370	41	41	246	41	21	41	123	2,054	Md	
A24	Unpacking&preparing	8304.41	126	19	32	32	13	13	13	13	63	6	6	114	13	13	76	13	6	13	38	632	Md	
A3	Foundation Preparing																							
A31	Interface Verifying	820.95	655		200	15	15		29	38	10	400	12	0	270	15	150	50	330	12	33	983	3,215	m2
A32	Embedments Installing	8258.82	164		60	2	2		4	5	1	60	12	0	68	10	38	12	83	6	8	123	636	m2
A33	Setting&Grouting	8708.53	44		13	15	15		29	38	10	27	3	0	17	8	5	35	22	2	18	0	298	m2
A4	Lifting On-Base																							
A41	Lifting/Hauling	8823.78	289		100	22	22		11	18	7	305		90	230	11	5	51	4	4	2	7	1,175	T
A42	Setting&Levelling	8666.03	289		100	22	22		11	18	7	305		90	230	11	5	51	4	4	2	7	1,175	T
A43	Inserting/Assembling	81,008.29	289									305		90	230				4				917	T
A44	Aligning&Coupling	81,987.42	35			4	16		2	4		1			49	4		6	12	10		2	145	d
A45	Key Fixing	8517.30	9			2	4		2	2	2	1			9	2		4	1	6		2	46	d
A5	System Piping																							
A51	Support Installing	8178.94		14	21	47	15	36	26	43	25	23	35			142	174	217	31		160	359	1,366	Sets
A52	Fitting-Up/Centering	8309.18		30	43	96	32	74	54	87	52	48	72			285	350	435	63		322	720	2,763	FW
A53	Welding/Bolting/Sealing	8200.64		30	43	96	32	74	54	87	52	48	72			285	350	435	63		322	720	2,763	FW
A54	NDT	844.97			43	96	32				52					285	350	435					1,293	FW
A55	Leak/Pressure Testing	83,985.76		3	2	1	1	1	1	1		1	1		3		2		1		1	2	21	d
A6	System Cleaning																							

Table B-4: Cost per Cost Object Report.

Source: Reprinted from Table 3-24.

A61	Flush-Pipes Installing	\$448.84		4	12	6	9	28	2	2	6	2	2			8	3	49	2		3	3	141	d	
A62	Initial Filling	\$762.98						6	14	14					15		49	13					111	d	
A63	Flushing/Blowing-Down	\$747.84		49	35	15	15	6	9	9	25	18	10			100	15	540	10		35	12	903	d	
A64	Final Restoration	\$583.42		4	12	6	9	28	2	2	6	2	2	0	0	35	3	70	2		3	3	189	d	
A7	Painting & Insulating																								
A71	Surface Preparing	\$67.58	352								175		490	6		220	62	8	250		3	46	45	1,656	m2
A72	Preventive Coating	\$163.87	352								175		490	6		220	62	8	250		3	46	45	1,656	m2
A73	Insulating & Lagging	\$524.43			75	5	5		9				122										49	266	m2
A74	Labelling/Tagging	\$1,251.25	1	1	1	1	1	1	1	1	1	1	1	1	1	1	1	1	1	1	1	1	1	20	Pckg
W/S	Workshop	\$784.45	407	12	12	25	25	12	12	12	12	25	12	12	345	25	25	185	12	37	12	12	1,232	Md	
VHC	Store Crane	\$369.64	514	82	21	41	41	21	4	21	21	103	21	41	489	164	82	246	21	82	21	21	2,054	Md	
ADM	Administration	\$47,589.81	1	1	1	1	1	1	1	1	1	1	1	1	1	1	1	1	1	1	1	1	1	20	Pckg
Total Overhead Costs			\$2,024,151	\$277,332	\$530,858	\$382,347	\$311,377	\$250,903	\$265,091	\$348,363	\$243,479	\$1,449,699	\$208,875	\$395,067	\$1,726,073	\$571,836	\$471,391	\$1,546,930	\$304,440	\$220,229	\$419,364	\$797,637	\$12,746,312		
Number of Packages			1	1	1	1	1	1	1	1	1	1	1	1	1	1	1	1	1	1	1	1	1	20	Pckg
Cost per Unit			\$2,024,151	\$277,332	\$530,858	\$382,347	\$311,377	\$250,903	\$265,091	\$348,363	\$243,479	\$1,449,699	\$208,875	\$395,067	\$1,726,073	\$571,836	\$471,391	\$1,546,930	\$304,440	\$220,229	\$419,364	\$797,637	\$12,746,312		

สถาบันวิทยบริการ
จุฬาลงกรณ์มหาวิทยาลัย

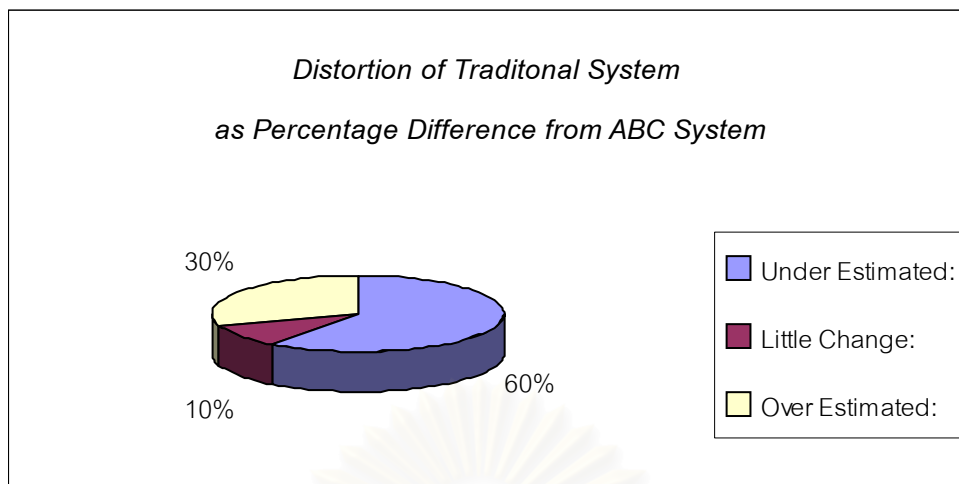

Figure B-2: Cost per Cost Object Comparative Report by its quantitative results of the distortion between traditional and ABC. (This indicates that for the product cost of MPD, in each of its total 20 packages there are only 2 packages or 10% of Total that are slightly change, whereas 18 out of its or 90% of Total have high significantly change i.e. 30% is overestimated and 60% underestimated).

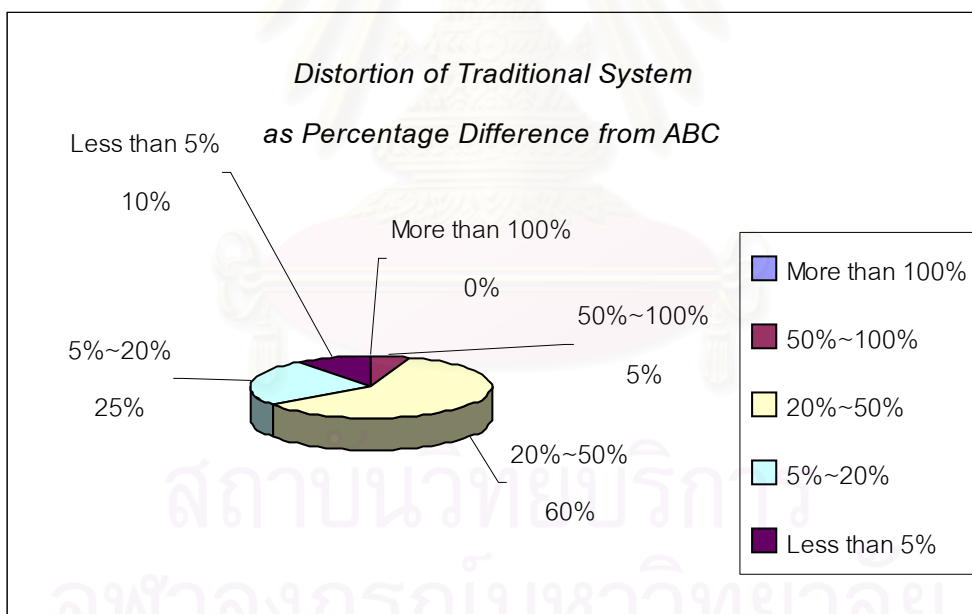

Figure B-3: Cost per Cost Object Comparative Report by its qualitative results of the distortion between traditional and ABC. (See more detail in section 4.4.2 ‘Qualitative Results’)

Table B-5: Comparison of results between the four sources of activity driver rate that used to calculate the Turbine installation activity cost (cost object no. 0411).

Activity				Activity Driver Rate of Package 0411												Remark
NODE	Description	Unit		ABC Approach		Traditional Approach			Best Practice Unit Price			Average Unit Cost				
			Volume	A/D Cost	A/D Rate	Volume	Activity Cost	A/D Rate	Volume	Activity Cost	A/D Rate	Volume	Activity Cost	A/D Rate		
A3	Foundation Preparing															
A31	Interface Verifying	m2	654.7	\$42,896	\$65.5	836.5	\$17,160	\$20.5	836.5	\$27,132	\$32.4	836.5	\$32,721	\$39.1		
A32	Embedments Installing	m2	163.7	\$52,282	\$319.5	209.1	\$164,120	\$784.8	209.1	\$29,675	\$141.4	209.1	\$35,667	\$170.5		
A33	Setting&Grouting	m2	43.6	\$78,373	\$1,795.7	55.8	\$431,280	\$7,733.3	55.8	\$101,760	\$1,824.5	55.8	\$122,709	\$2,200.3		
A4	Lifing On-Base															
A41	Lifting/Hauling	T	288.6	\$364,249	\$1,262.0	364.0	\$87,200	\$239.6	364.0	\$139,650	\$383.7	364.0	\$168,416	\$462.7		
A42	Setting&Leveling	T	288.6	\$380,802	\$1,319.3	364.0	\$539,847	\$1,483.1	364.0	\$359,898	\$988.7	364.0	\$434,031	\$1,192.4		
A43	Inserting/Assembling	T	288.6	\$256,080	\$887.2	364.0	\$821,142	\$2,255.9	364.0	\$547,428	\$1,503.9	364.0	\$660,189	\$1,813.7		
A44	Aligning&Coupling	d	35.0	\$45,195	\$1,291.3	49.0	\$231,021	\$4,714.7	7.0	\$154,014	\$22,002.0	7.0	\$185,738	\$26,534.1		
A45	Key Fixing	d	9.0	\$18,911	\$2,101.2	5.0	\$82,593	\$16,518.6	5.0	\$55,062	\$11,012.4	5.0	\$66,404	\$13,280.8		
A5	System Piping															
A51	Support Installing	Sets	0.0	\$0	\$0.0	0.0	\$0	\$0.0	0.0	\$0	\$0.0	0.0	\$0	\$0.0		
A52	Fitting-Up/Centering	FW	0.0	\$0	\$0.0	0.0	\$0	\$0.0	0.0	\$0	\$0.0	0.0	\$0	\$0.0		
A53	Welding/Bolting/Sealing	FW	0.0	\$0	\$0.0	0.0	\$0	\$0.0	0.0	\$0	\$0.0	0.0	\$0	\$0.0		
A54	NDT	FW	0.0	\$0	\$0.0	0.0	\$0	\$0.0	0.0	\$0	\$0.0	0.0	\$0	\$0.0		
A55	Leak/Pressure Testing	d	0.0	\$0	\$0.0	0.0	\$0	\$0.0	0.0	\$0	\$0.0	0.0	\$0	\$0.0		
A6	System Cleaning															
A61	Flush-Pipes Installing	d	0.0	\$0	\$0.0	0.0	\$0	\$0.0	0.0	\$0	\$0.0	0.0	\$0	\$0.0		
A62	Initial Filling	d	0.0	\$0	\$0.0	0.0	\$0	\$0.0	0.0	\$0	\$0.0	0.0	\$0	\$0.0		
A63	Flushing/Blowing-Down	d	0.0	\$0	\$0.0	0.0	\$0	\$0.0	0.0	\$0	\$0.0	0.0	\$0	\$0.0		
A64	Final Restoration	d	0.0	\$0	\$0.0	0.0	\$0	\$0.0	0.0	\$0	\$0.0	0.0	\$0	\$0.0		
A7	Painting& Insulating															
A71	Surface Preparing	m2	352.1	\$15,396	\$43.7	632.0	\$8,326	\$13.2	632.0	\$5,651	\$8.9	632.0	\$6,694	\$10.6		
A72	Preventive Coating	m2	352.1	\$92,761	\$263.4	632.0	\$24,977	\$39.5	632.0	\$16,652	\$26.3	632.0	\$20,081	\$31.8		
A73	Insulating&Lagging	m2	0.0	\$0	\$0.0	0.0	\$0	\$0.0	0.0	\$0	\$0.0	0.0	\$0	\$0.0		
A74	Labeling/Tagging	Pckg	1.0	\$0	\$0.0	1.0	\$0	\$0.0	0.0	\$0	\$0.0	0.0	\$0	\$0.0		

Biography

Mr. Tongchai Iemkanitchat was born on April 19, 1970 in Chiangmai, Thailand. He graduated from the Department of Mechanical Engineering, Faculty of Engineering, Chiangmai University in October 1992.

He has worked for the case organisation since 1992. After that, in 1998 he got a full scholarship from the case organisation to continue studying in Engineering Management at the Regional Centre for Manufacturing Systems Engineering at Chulaongkorn University. At present, he is working as a Mechanical Engineer for the Department of Thermal Power Plant Construction of the case organisation.



สถาบันวิทยบริการ
จุฬาลงกรณ์มหาวิทยาลัย