

**STOCHASTIC SUPPLY CHAIN OPTIMIZATION FOR AMMONIA AND  
UREA PROCESSES**

Seangplang Srisamut

A Thesis Submitted in Partial Fulfillment of the Requirements  
for the Degree of Master of Science  
The Petroleum and Petrochemical College, Chulalongkorn University  
in Academic Partnership with  
The University of Michigan, The University of Oklahoma,  
Case Western Reserve University, and Institut Français du Pétrole  
2020

บทคัดย่อและแฟ้มข้อมูลฉบับเต็มของวิทยานิพนธ์ตั้งแต่ปีการศึกษา 2554 ที่ให้บริการในคลังปัญญา (CUIR)  
เป็นแฟ้มข้อมูลของนิสิตเจ้าของวิทยานิพนธ์ที่ส่งผ่านทางบัณฑิตวิทยาลัย



2619937106

The abstract and full text of theses from the academic year 2011 in Chulalongkorn University Intellectual Repository (CUIR)  
are the thesis authors' files submitted through the Graduate School.

# Stochastic Supply Chain Optimization for Ammonia and Urea Processes

Mr. Seangplang Srisamut

A Thesis Submitted in Partial Fulfillment of the Requirements  
for the Degree of Master of Science in Petroleum and Energy Technology  
Common Course  
the Petroleum and Petrochemical College  
Chulalongkorn University  
Academic Year 2019  
Copyright of Chulalongkorn University

2619937106  
CD IThesis 6173002063 thesis / recv: 20072563 10:48:08 / seq: 18

การหาค่าที่เหมาะสมที่สุดแบบสโตแคสติกสำหรับห่วงโซ่อุปทานของกระบวนการผลิตแอมโมเนีย  
และยูเรีย

นายเสียงเพลง ศรีสมุทร

วิทยานิพนธ์นี้เป็นส่วนหนึ่งของการศึกษาตามหลักสูตรปริญญาวิทยาศาสตรมหาบัณฑิต  
สาขาวิชาเทคโนโลยีปิโตรเลียมและพลังงาน ไม่สังกัดภาควิชา/...  
วิทยาลัยปิโตรเลียมและปิโตรเคมี จุฬาลงกรณ์มหาวิทยาลัย  
ปีการศึกษา 2562  
ลิขสิทธิ์ของจุฬาลงกรณ์มหาวิทยาลัย

Thesis Title                      Stochastic Supply Chain Optimization for Ammonia and Urea Processes  
By                                      Mr. Seangplang Srisamut  
Field of Study                      Petroleum and Energy Technology  
Thesis Advisor                      Assistant Professor KITIPAT SIEMANOND, Ph.D.

---

Accepted by the the Petroleum and Petrochemical College, Chulalongkorn University in Partial Fulfillment of the Requirement for the Master of Science

..... Dean of the the Petroleum and Petrochemical College  
(Professor SUWABUN CHIRACHANCHAI, Ph.D.)

THESIS COMMITTEE

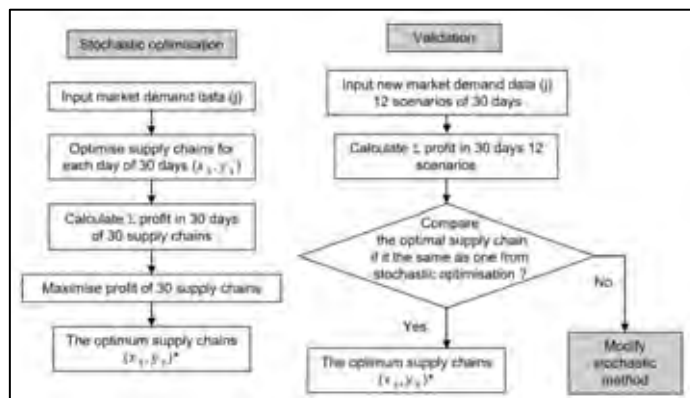
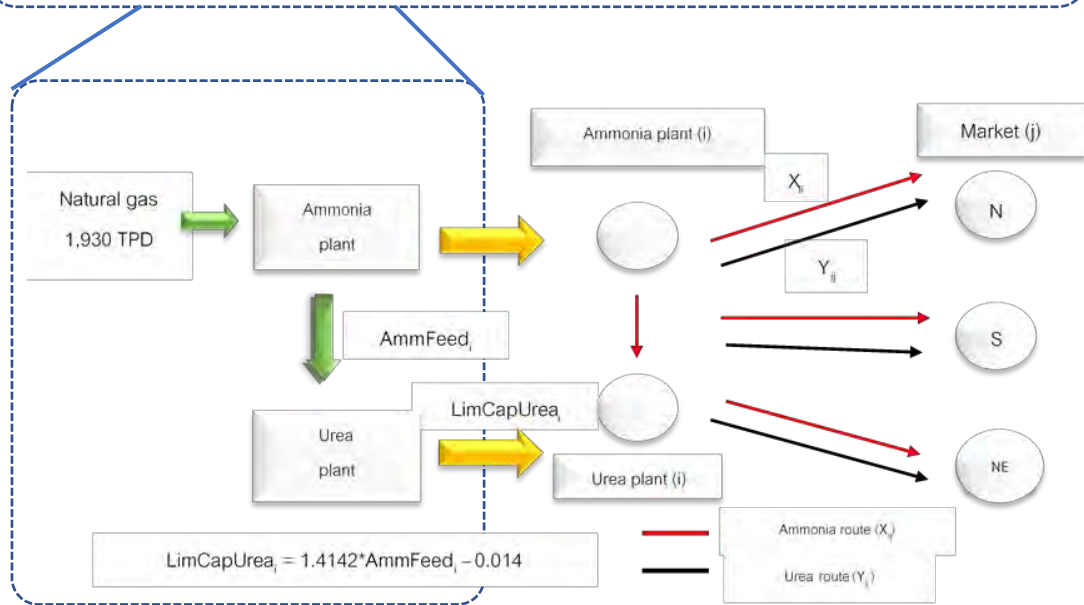
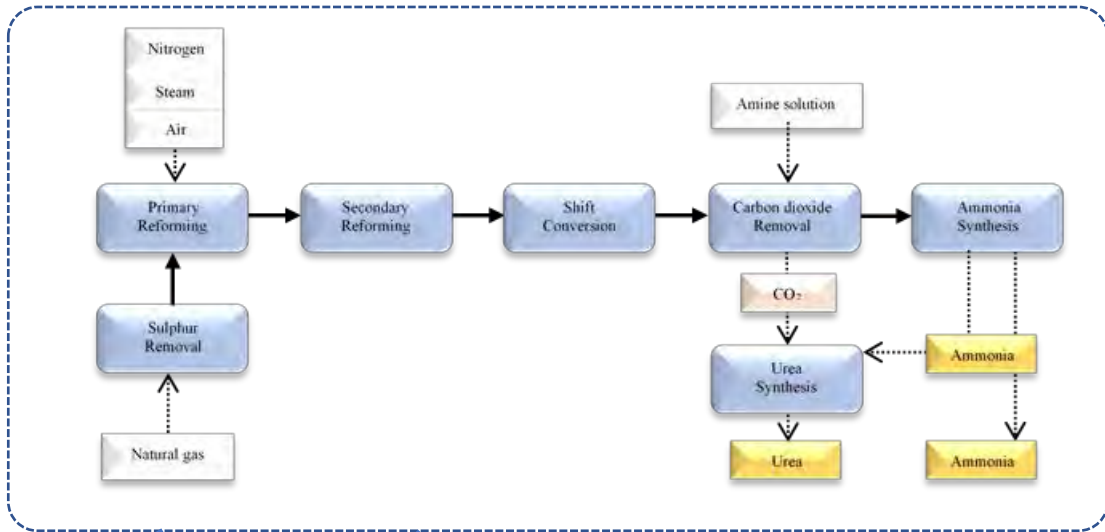
..... Chairman  
(Professor BOONYARACH KITIYANAN, Ph.D.)  
..... Thesis Advisor  
(Assistant Professor KITIPAT SIEMANOND, Ph.D.)  
..... External Examiner  
(Assistant Professor Chanin Panjapornpon, Ph.D.)



2619937106

CD IThesis 6173002063 thesis / recv: 20072563 10:48:08 / seq: 18

# GRAPHICAL ABSTRACT



เสียงเพลง ศรีสมุทร : การหาค่าที่เหมาะสมที่สุดแบบสโตแคสติกสำหรับห่วงโซ่อุปทานของกระบวนการผลิตแอมโมเนียและยูเรีย. ( Stochastic Supply Chain Optimization for Ammonia and Urea Processes) อ.ที่ปรึกษาหลัก : ผศ. ดร.กิติพัฒน์ สีมานนท์

มีเทนจากก๊าซธรรมชาติสามารถใช้เป็นวัตถุดิบในกระบวนการผลิตแอมโมเนียและยูเรียได้ เพื่อรองรับการเติบโตของอุปสงค์ในภาคเกษตรกรรมการผลิตจากจำนวนประชากรที่เพิ่มขึ้นอย่างต่อเนื่อง อย่างไรก็ตามโรงงานทั่วไปที่ใช้วัตถุดิบจากก๊าซธรรมชาติจะผลิตก๊าซคาร์บอนไดออกไซด์เป็นผลพลอยได้ของกระบวนการ โรงงานที่นำเสนอนี้มีสองกระบวนการผลิตคือแอมโมเนียและยูเรีย ซึ่งมีประสิทธิภาพในการผลิตมากขึ้น โดยผลผลิตพลอยได้ก๊าซคาร์บอนไดออกไซด์สามารถนำมาใช้เป็นสารตั้งต้นในการผลิตยูเรียมากขึ้นและลดการปล่อยก๊าซคาร์บอนไดออกไซด์ งานวิจัยนี้นำเสนอกระบวนการสังเคราะห์แอมโมเนียและยูเรียโดยใช้โปรแกรม PROII เพื่อจำลองกระบวนการทำงานและประเมินการใช้พลังงาน เพื่อให้สามารถทำการตลาดและทำกำไรให้กับอุตสาหกรรม จึงได้มีการนำการวิเคราะห์ทางเศรษฐศาสตร์และเทคนิคสโตแคสติกมาใช้ในการจัดการกับความต้องการที่ไม่แน่นอนจากตลาด งานวิจัยนี้ประกอบด้วยสามส่วนหลัก ส่วนแรกเป็นการจำลองกระบวนการพื้นฐานของโรงงานผลิตแอมโมเนียและยูเรีย โดยนำเข้าข้อมูลและค่าพารามิเตอร์ที่ได้มาจากอุตสาหกรรมปิโตรเคมีในประเทศไทย ในส่วนที่สองการวิเคราะห์ทางด้านเทคนิคและเศรษฐกิจ ซึ่งมีความสำคัญสำหรับการศึกษาความเป็นไปได้ในการประเมินค่าใช้จ่ายและความสามารถในการทำกำไรของโครงการ ในส่วนสุดท้าย คือการวิเคราะห์แบบสโตแคสติกเพื่อนำมาใช้เพิ่มประสิทธิภาพอัตราการผลิตและห่วงโซ่อุปทานของผลิตภัณฑ์จากความต้องการที่แปรปรวนของตลาด ห่วงโซ่อุปทานที่ได้รับการปรับปรุงและการตรวจสอบเกี่ยวกับ อัตราการผลิต ผลของค่าเสียโอกาสและค่าปรับ และความเป็นไปได้ในการทำกำไรผ่านกราฟผลกำไรสะสม การออกแบบแนวคิดของกระบวนการผลิตมีจุดมุ่งหมายในการผลิตแอมโมเนียและยูเรียจากก๊าซธรรมชาติ 1,930 ตัน/วัน ใช้เป็นวัตถุดิบ

สาขาวิชา           เทคโนโลยีปิโตรเลียมและพลังงาน  
ปีการศึกษา        2562

ลายมือชื่อนิสิต .....

ลายมือชื่อ อ.ที่ปรึกษาหลัก .....

## 6173002063 : MAJOR PETROLEUM AND ENERGY TECHNOLOGY

KEYWORD Stochastic/ Optimization/ Supply Chain/ Simulation/ Ammonia/  
D: Urea

Seangplang Srisamut : Stochastic Supply Chain Optimization for  
Ammonia and Urea Processes. Advisor: Asst. Prof. KITIPAT  
SIEMANOND, Ph.D.

To support the demand growth in the agriculture sector from increasing population, ammonia and urea productions have been continuously increasing. Methane from natural gas can be used as feedstock in the production process. Nevertheless, the conventional plant using natural gas feedstock produces carbon dioxide as a by-product of the process. This proposed plant contains two processes, producing ammonia and urea can be more efficient in the production, where the by-products of CO<sub>2</sub> can be used to produce more urea and reduce CO<sub>2</sub> emission. This research proposes ammonia and urea synthesis process using PROII software to simulate workflow and estimate the energy consumption. To be marketable and profitable for the agricultural industry, the techno-economic and stochastic analysis are applied to deal with uncertain demand from the market. This work is comprised of three main parts; the first part is the simulation of the base case process of the proposed ammonia/urea plant. The input data and parameters are obtained from the petrochemical industry in Thailand. In the second part, techno-economic analysis is significant for a feasibility study to estimate expenditure and the profitability of the project. Finally, the stochastic analysis is applied to optimize the production rate and supply chain of the products from various demands of the markets. The optimized supply chain network has been investigated on the production rate, the effect of penalty, and profit feasibility through profit accumulative curve. The conceptual design of manufacturing processes attempts to produce ammonia and urea, based on 1,930 t/d of natural gas feedstock.

Field of Study:	Petroleum and Energy Technology	Student's Signature .....
Academic Year:	2019	Advisor's Signature .....

## ACKNOWLEDGEMENTS

The author would like to deeply gratitude to Asst. Prof. Kitipat Siemanond, for his expertly guidance, valuable comments, and suggestions on my thesis.

Besides my advisor, I would also like to extend my appreciation to the thesis examination committee, Asst. Prof. Chanin Panjapornpon and Prof. Boonyarach Kitiyanan for the useful suggestion and information.

I extend my next appreciation to all lecturers and staff in the Petroleum and Petrochemical College, who have sincerely helped me during academic year and research process periods.

Furthermore, I am grateful for the full scholarship and full funding of the thesis work provided by the Petroleum and Petrochemical College and Center of Excellence on Petrochemical and Materials Technology.

Finally, my deeply gratitude also extends to my family and my friends, for their worthy support and encouraged me in this effort. This accomplishment would not have been possible without them.

Seangplang Srisamut



# TABLE OF CONTENTS

	<b>Page</b>
ABSTRACT (THAI) .....	iii
ABSTRACT (ENGLISH).....	iv
ACKNOWLEDGEMENTS .....	v
TABLE OF CONTENTS.....	vi
LIST OF TABLES .....	ix
LIST OF FIGURES .....	xi
CHAPTER 1 INTRODUCTION .....	1
CHAPTER 2 LITERATURE REVIEW .....	3
2.1 Ammonia, Urea Characteristic .....	3
2.2 Application of Ammonia, Urea .....	3
2.3 Feed Source of Ammonia, Urea .....	8
2.4 The Market of Ammonia and Urea.....	11
2.5 Ammonia and Urea Production .....	14
2.6 Ammonia Manufacturing Process .....	14
2.6.1 Ammonia Plant Design .....	19
2.6.2 Modern Production Processes .....	21
2.6.3 Plant Designs in the 21st Century .....	22
2.7 Urea Manufacturing Process.....	28
2.8 Techno-Economic Analysis (TEA) .....	33
2.8.1 Capital Expenditure (CAPEX) Estimation.....	34
2.8.2 Operating Expenditure (OPEX) Estimation .....	34
2.8.3 Profitability Analysis.....	34
2.8.4 Sensitivity Analysis .....	34

2.8.5 Equipment Design and Cost Estimation.....	35
2.8.5.1 Reactor.....	35
2.8.5.2 Flash Drum.....	35
2.8.5.3 Distillation Column.....	36
2.8.5.4 Centrifugal Pump.....	36
2.8.5.5 Compressor.....	36
2.8.5.6 Fired Heater.....	37
2.9 Stochastic Model.....	37
CHAPTER 3 EXPERIMENTAL.....	39
3.1 Materials and Equipment.....	39
3.1.1 Equipment.....	39
3.1.2 Softwares.....	39
3.2 Objectives and Scope of Research Work.....	39
3.2.1 Objectives.....	39
3.2.2 Scope of Research Work.....	40
3.3 Methodology.....	40
3.3.1 Simulation for Ammonia and Urea Manufacturing Processes.....	40
3.3.2 Investment Expenditures of Ammonia and Urea Plants Assessment.....	40
3.3.3 Case Studies.....	40
CHAPTER 4 RESULTS AND DISCUSSION.....	43
4.1 Properties and Specification for Simulation Processes – Ammonia Plant.....	43
4.2 Process Flow Diagram – Case 1 Ammonia Manufacturing Process.....	47
4.2.1 A Conceptual Design of Ammonia Production – Stage 1 Catalytic Reforming.....	47
4.2.2 A Conceptual Design of Ammonia Production – Stage 2 Shift Conversion and Gas Sweetening.....	47
4.2.3 A Conceptual Design of Ammonia Production – Stage 3 Compression..	48
4.2.4 A Conceptual Design of Ammonia Production – Stage 4 Conversion ....	48
4.3 Energy Consumption Analysis – Ammonia Manufacturing Process.....	53
4.4 Properties and Specification for Simulation Processes – Urea Plant.....	59

4.5 Process Flow Diagram – Case 2 Urea Manufacturing Process .....	61
4.6 Energy Consumption Analysis – Urea Manufacturing Process .....	63
4.7 Techno Economic Analysis of the Manufacturing Process .....	65
4.7.1 Fixed Capital Cost .....	65
4.7.1.1 Direct Manufacturing Expenditure .....	65
4.7.1.2 Indirect Manufacturing Expenditure .....	65
4.7.2 Working Capital Investment .....	65
4.7.3 Depreciable Investment .....	65
4.7.4 Expenditure Assessment for Ammonia and Urea Processes .....	66
4.8 Investigation on Optimization of Market Demand (with Fixed Production Capacity of Ammonia and Urea) .....	75
4.9 Investigation on Optimization of Market Demand (with Varied Production Capacity of Ammonia and Urea) .....	97
CHAPTER 5 CONCLUSION .....	117
APPENDICES .....	120
Appendix A .....	120
Appendix B .....	122
Appendix C .....	126
Appendix D .....	128
REFERENCES .....	130
VITA .....	133

## LIST OF TABLES

	<b>Page</b>
<b>Table 4.1</b> Compositions of natural gas feed.....	43
<b>Table 4.2</b> Properties of steam feed.....	44
<b>Table 4.3</b> Properties of air feed.....	44
<b>Table 4.4</b> Properties of water make up.....	44
<b>Table 4.5</b> Ammonia production specification.....	44
<b>Table 4.6</b> Input data of ammonia process.....	45
<b>Table 4.7</b> Overall energy consumption for ammonia manufacturing process.....	53
<b>Table 4.8</b> Energy consumption of ammonia production in stage 1.....	55
<b>Table 4.9</b> Energy consumption of ammonia production in stage 2.....	56
<b>Table 4.10</b> Energy consumption of ammonia production in stage 3.....	57
<b>Table 4.11</b> Energy consumption of ammonia production in stage 4.....	58
<b>Table 4.12</b> Ammonia feed for urea manufacturing process.....	59
<b>Table 4.13</b> Carbon dioxide feed for urea manufacturing process.....	59
<b>Table 4.14</b> Urea product specification.....	60
<b>Table 4.15</b> Input data of urea process.....	60
<b>Table 4.16</b> Energy consumption of urea production.....	63
<b>Table 4.17</b> Utility cost coefficient with 470 of CEPCI and 7.2 of $C_{s,f}$ .....	66
<b>Table 4.18</b> Expenditure assessment for ammonia manufacturing process.....	67
<b>Table 4.19</b> Expenditure assessment for urea manufacturing process from 3,870 TPD ammonia feed.....	69
<b>Table 4.20</b> Detail Purchased Equipment Cost.....	71
<b>Table 4.21</b> Detail total expenditure for ammonia and urea manufacturing.....	71
<b>Table 4.22</b> Key assumptions used to develop the techno-economic model.....	72
<b>Table 4.23</b> Correlation between ammonia feed to urea product.....	73
<b>Table 4.24</b> The data related to the network.....	77
<b>Table 4.25</b> The result of supply chains model network – fixed production capacity of ammonia and urea.....	79

<b>Table 4.26</b> The optimal value of ammonia and urea transportation for 30 days (historical) .....	88
<b>Table 4.27</b> The result of supply chains model network – varied production capacity of ammonia and urea .....	100
<b>Table 4.28</b> The optimal value of Ammonia and Urea for 30 days – varied ammonia and urea production rate (historical) .....	108
<b>Table 5.1</b> Concluded information and key parameters of manufacturing process...118	
<b>Table 5.2</b> Concluded information and key parameters of supply chain optimization .....	119



2619937106

CU IThesis 6173002063 thesis / recv: 20072563 10:48:08 / seq: 18

## LIST OF FIGURES

	<b>Page</b>
<b>Figure 2.1</b> Ammonia Market by End-user Industry, Global, 2019 and 2024 .....	4
<b>Figure 2.2</b> Feedstock sources of ammonia production in the world. ....	8
<b>Figure 2.3</b> Ammonia Market – Growth Rate by Region, 2019-2024. ....	11
<b>Figure 2.4</b> Worldwide ammonia production has continued increased from 1946 to 2014.....	12
<b>Figure 2.5</b> Overall production process for ammonia and urea plants. ....	14
<b>Figure 2.6</b> Schematic representation of the ammonia synthesis process. ....	17
<b>Figure 2.7</b> Haldor Topsoe Process Flow Sheet of Ammonia Production. ....	20
<b>Figure 2.8</b> A simplified flowsheet of the first commercial ammonia plant by BASF. ...	23
<b>Figure 2.9</b> KBR designed one of the first single-train, large-capacity ammonia plants. ...	24
<b>Figure 2.10</b> Modern ammonia plants designed by KBR employ its proprietary Purifier. ....	25
<b>Figure 2.11</b> Haldor Topsøe offers an ammonia plant design that has a proprietary side-fired reformer in which radiant burners supply heat for the reforming reaction. ....	26
<b>Figure 2.12</b> The Linde Ammonia Concept (LAC) features a pressure-swing adsorption unit for high-purity hydrogen production and an air separation unit for high-purity nitrogen production.....	27
<b>Figure 2.13</b> Schematic representation of urea synthesis. ....	29
<b>Figure 2.14</b> Scheme of the conventional process for urea production from natural gas. ....	31
<b>Figure 2.15</b> Proposed plant for urea production using chemical looping process (before heat and power integration). ....	32
<b>Figure 2.16</b> Overall methodology approach for techno-economic analysis. ....	33
<b>Figure 2.17</b> Structure of integrated forward/reverse logistics network. ....	38
<b>Figure 4.1</b> The simulation of ammonia production – stage 1 Catalytic reforming....	49
<b>Figure 4.2</b> The simulation of ammonia production – stage 2 shift conversion and gas sweetening.....	50
<b>Figure 4.3</b> The simulation of ammonia production – stage 3 compression. ....	51
<b>Figure 4.4</b> The simulation of ammonia production – stage 4 ammonia conversion. ...	52

<b>Figure 4.5</b> Overall energy consumption of ammonia manufacturing process. ....	54
<b>Figure 4.6</b> Energy consumption of ammonia process in stage 1. ....	55
<b>Figure 4.7</b> Energy consumption of ammonia process in stage 2. ....	56
<b>Figure 4.8</b> Energy consumption of ammonia process in stage 3. ....	57
<b>Figure 4.9</b> Energy consumption of ammonia process in stage 4. ....	58
<b>Figure 4.10</b> The simulation of urea production.....	62
<b>Figure 4.11</b> Energy consumption of urea process.....	64
<b>Figure 4.12</b> Expenditure of ammonia process divided by utility type.....	70
<b>Figure 4.13</b> Expenditure of urea process divided by utility type.....	70
<b>Figure 4.14</b> Correlation between ammonia to urea product.....	74
<b>Figure 4.15</b> Urea utilities expenditure correlation with urea product.....	74
<b>Figure 4.16</b> The simple supply chain network diagram.....	77
<b>Figure 4.17</b> Ammonia and urea demands of each market.....	78
<b>Figure 4.18</b> The results from validation part of 12 scenarios – fixed production rate. .....	93
<b>Figure 4.19</b> The new set of uncertainty market’s demands of ammonia and urea in 12 scenarios, 30 days per scenarios (360 days) for validation part. ....	94
<b>Figure 4.20</b> profit cumulative frequency curve for supply chain No.12, No13, and deterministic one.....	96
<b>Figure 4.21</b> The simple network diagram for varied production capacity of ammonia and urea.....	99
<b>Figure 4.22</b> The results from validation part of 12 scenarios – varied production rate. .....	113
<b>Figure 4.23</b> Profit cumulative frequency curve for stochastic supply chains No.9, No. 12, No.23, and deterministic one – varied production capacity.....	114

## CHAPTER 1

### INTRODUCTION

Ammonia is one of important chemicals in the world. The use of ammonia to produce fertilizer has been increasing every year, relating to growing global population and increasing agriculture demand. Ammonia can be a feedstock to produce urea, the important chemical of nitrogen-based fertilizer and a widely used intermediate in the chemical industry. Ammonia can be used in various application such as solid ammonia energy carrier, liquid ammonia in cooling system, agriculture, chemical intermediate, polymer substance (synthesis fiber), etc.

Ammonia is a colorless, pungent smell gas and weak alkali which is very soluble in water. Ammonia is a compound of nitrogen and hydrogen with the formula  $\text{NH}_3$ . Mass production of Ammonia mostly uses the Haber–Bosch process, reacting hydrogen ( $\text{H}_2$ ) and nitrogen ( $\text{N}_2$ ) at a moderately-elevated temperature and high pressure.(Chisholm, 1911) Urea is an organic compound with the formula  $\text{CO}(\text{NH}_2)_2$ .

Urea is produced from ammonia and carbon dioxide. The urea synthesis process consists of two main equilibrium reactions. The first is call carbamate formation, that is exothermic reaction of liquid ammonia with gaseous carbon dioxide ( $\text{CO}_2$ ) at high temperature and pressure. The second is called urea conversion, that is endothermic decomposition of ammonium carbamate into urea and water (Meessen and Petersen, 2000).

This research proposes the ammonia and urea synthesis process by using the PROII software to simulate workflow and estimate the energy consumption. This conceptual manufacturing process has production capacity about 3,000-4,000 ton per day for ammonia and 5,000 ton per day for urea, based on obtained data from Thailand's industrial section. The feedstock of the process is methane from natural gas.

In the production process, it has many expenditures on feedstock which are from utilities, chemicals, equipment, operating cost and treatment unit. To be marketable and profitable to industrials, the techno-economic evaluation is considered in this work. Techno-economic evaluation is a methodology framework to analyze the technical and economic efficiency of a process, product or service. It normally



combines process modeling, engineering design and economic assessment. The techno-economic evaluation is a key of feasibility study to estimate project expenditure and profitability. This technique represents the capital cost, the operating cost, net present value, and payback period.

For more benefit, this research also includes the stochastic analysis to design optimal supply chain with production rate of ammonia and urea from plant to markets. the stochastic analysis is a basic tool in probability theory and is used in many applied areas especially statistical mechanics. It has become particularly formula as a way of modelling financial markets and strategies. Stochastic programming model also be used in logistics network design under uncertainty. One of the most important and strategic issues in supply chain management is the configuration of the logistics network that has a significant effect on the total performance of the supply chain



2619937106

CU IThesis 6173002063 thesis / recv: 20072563 10:48:08 / seq: 18

## CHAPTER 2

### LITERATURE REVIEW

#### 2.1 Ammonia, Urea Characteristic

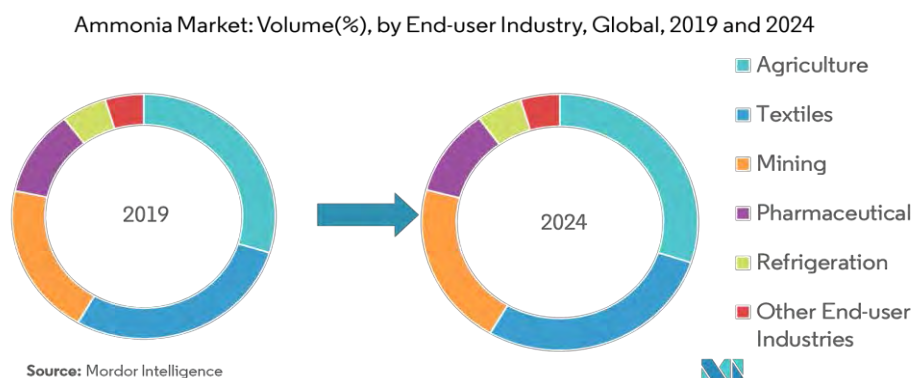
Ammonia is a compound of nitrogen and hydrogen with the chemical formula  $\text{NH}_3$ . It is a colorless gas with a characteristic acrid smell. Ammonia is lighter than air, its density is 0.589 times that of air. It is easily liquefied due to the strong hydrogen bonding between molecules; the liquid boils at  $-33.3\text{ }^\circ\text{C}$  ( $-27.94\text{ }^\circ\text{F}$ ), and freezes at  $-77.7\text{ }^\circ\text{C}$  ( $-107.86\text{ }^\circ\text{F}$ ) to white crystals (Chisholm, 1911). Ammonia is a chemical found in trace amounts in nature, it is produced naturally in human body and being produced from nitrogenous animal and plants matter. Ammonia and the ammonium ion are vital components of metabolic processes.

Urea is an organic compound of amide and carbonyl group with chemical formula  $\text{CO}(\text{NH}_2)_2$ . It is also known as carbamide. It is a solid odorless white crystal and noncombustible. It is very soluble in water but insoluble in ether, with a melting point at  $132\text{ }^\circ\text{C}$ . Urea is one of the most widely produced chemicals in the world and based on demand for crops and fertilizer has been increased. More than 90% of the production of urea in the world is used for a nitrogen-release fertilizer.(Meessen and Petersen, 2000).

#### 2.2 Application of Ammonia, Urea

Ammonia can be used in various applications such as fertilizer, explosive, dyes, household cleaners, energy carrier, chemical intermediate, Polymer substance (synthesis fiber), etc. The agriculture industry dominates the global ammonia market, with an estimated market share of more than 80% in 2018. Ammonia is majorly used in fertilizers, and its usage has been increasing through the years, thereby, driving its usage in the agriculture market. Urea is a dry nitrogen material produced by reacting ammonia with carbon dioxide. Urea has the highest percentage of nitrogen among the

commonly used dry fertilizers and is rapidly replacing ammonium nitrate in recent years.



**Figure 2.1** Ammonia Market by End-user Industry, Global, 2019 and 2024 (Mordor Intelligence, 2018).

From figure 2.1, it illustrates the major ammonia market is Agriculture section. The rest are textiles, mining, pharmaceutical, refrigeration, and other end-user industries. The forecast period of 2019-2024, the market's demand is increasing in the agriculture industry and the production of explosives (Intelligence, 2018).

M. Raihanul Islam Chowdhury et al., (2002) researched effect of different methods of urea application on growth and yield in potato. The research was conducted to find out appropriate methods of urea application for maximizing the production of potato. There was a significant effect of different methods of urea application on plant emergence. The delay in plant emergence might be due to the accumulation of free ammonia and nitrites in the soil after the incorporation of urea. Application of urea as 50 % basal + 50 % top dressing produced the best result among the methods, and it was found to be the most cost effective. It might be concluded that split application of urea is the effective way to avoid the detrimental effect of urea on plant emergence and to maximize the tuber yield in Bangladesh (Chowdhury, 2002).

Debasish Chakraborty et al., (2009) studied for solid ammonia. This studied aim at the potential of 'solid' ammonia as a carbon-free energy carrier for mobile and transport applications, system integration and future opportunities. The result of this

research illustrates that ammonia as a fuel cell for solid oxide fuel cell has some advantages over hydrocarbon fuels. The advantages include no desulfurization, and no pre-reforming requirement for ammonia. The combination of the direct ammonia fuel cell and the solid ammonia storage is very attractive for automotive applications, for several reasons. First, the operating temperature (400–600°C) of this type of fuel cell is ideal for ammonia decomposition. So, there is a very good synergy between the reforming and fuel cell operation. Furthermore, the thermal desorption of ammonia from the solid storage materials can be achieved using the ‘waste’ heat from the stack, because the waste heat from a direct ammonia fuel cell stack operating at ~500°C will be of very good ‘quality’ to utilize for degassing ammonia. This will improve the overall system efficiency. Finally, the startup time much lower than the solid oxide fuel cell. This relatively lower operating temperature will also offer more options for materials selection (Chakraborty, 2009).

Sirinapa Santipanusopon, and Sa-Ad Riyajan (2009) studied the effect of ammonia treatment in field natural rubber latex with different storage period time on the properties of concentrated natural rubber latex and stability of skim latex. Fresh natural rubber latex was treated with various ammonia contents, 0.35, 0.60 and 0.80% w/w. The effect of storage time was observed with 0, 15, 30 and 45 days for concentrated natural rubber latex with different ammonia contents. This research demonstrated that magnesium content in field natural rubber latex and latex concentrate decreased with storage period times. The increasing ammonia content lead to the increment of the alkalinity content in both concentrated natural rubber and skim latex (Santipanusopon and Riyajan, 2009).

Zhe Han et al., (2015). The ammonia has been used as substrate for fertilizer such as ammonium nitrate. In this studied, the researchers focus on the alternatives to make ammonium nitrate safer as a fertilizer by reducing its explosivity. The effect of inhibitors, confinement, and heating rate on ammonium nitrate thermal decomposition has been studied. The results show that different types of additives, including sodium bicarbonate, potassium carbonate, and ammonium sulfate are good inhibitors for ammonium nitrate. The effect of confinement is concluded that confinement is dangerous to ammonium nitrate, which should be avoid in ammonium nitrate storage

and transportation. The effect of heating rate shown that the lower heating rate lead to the lower the “onset” temperature detected (Han, 2015).

S. Seifi at al., (2016) studied Kaolin intercalated by urea for ceramic applications. They prepared Kaolinite-urea complexes by mixing and ball-milling at room temperature. Urea-intercalated kaolinite has potential applications in industry. This research found that the thermal transformations of intercalated kaolin with urea occur with several mechanisms depending on temperature. The expansion of kaolinite is involved to entering urea into inter-layers that confirms the occurrence of hydrogen bonding between urea and kaolinite. At expanded interlayers, bonds are formed between inner-surface hydroxyls of kaolinite and NH groups of urea that contribute to obtain physical properties of intercalated kaolinite similarly to delaminated kaolinite by intensive grinding that reduce the sintering temperature of more than 25°C, accelerating the densification rate. It was sufficient to induce a significant reduction of the specific energy consumption during large scale manufacturing of clay ceramics for building (Seifi, 2016).

Orbel Barkhordarian at al., (2017) researched a novel ammonia-water cogeneration system that combined power and refrigeration cycle to produce power and refrigeration outputs simultaneously. This cycle has two evaporators that can produce refrigeration output in two different temperature levels and capacities. Ammonia was used in field regarding refrigerating application. One of the key parameters that effect on the cycle performance is ammonia concentration. The effect of evaporator outlet temperature is obvious that refrigeration output decreasing with increasing of basic solution ammonia concentration. They also investigated the effect of key parameters and It is shown that the cycle’s thermal performance is acceptable with exergy efficiency of 38.9%, effective exergy efficiency of 42.75% and thermal efficiency of 19% for the base case study (Barkhordarian, 2017).

Jiana Chen at al., (2017) studied effect of urea on nitrogen metabolism and membrane lipid peroxidation in *Azolla pinnata*. They reported the application of urea to *Azolla pinata* resulted in 44% decrease in nitrogenase activity, no significant change in glutamine synthetase activity, 660% higher glutamic-pyruvic transaminase, 39% increase in free amino acid levels, 22% increase in malondialdehyde levels, 21% increase in Na<sup>+</sup>/K<sup>+</sup> levels, 16% in Ca<sup>2+</sup> /Mg<sup>2+</sup> ATPase levels, and 11% decrease in

superoxide dismutase activity. Urea treatment of *Azolla* induced an increase in glutamic-pyruvic transaminase (GPT) and catalase (CAT) activity and free amino and Malondialdehyde (MDA) concentrations and a decrease in nitrogenase and superoxide dismutase (SOD) activity. These findings demonstrate that urea application promotes amino acid metabolism and membrane lipid peroxidation in *Azolla pinnata*. These studies estimated the associated urea demand for energy crops (Chen, 2017).

Kiyoshi Sakuragi et al., (2018) researched the application of ammonia pretreatment to enable enzymatic hydrolysis of hardwood biomass. Ammonia pretreatment majorly improved enzymatic hydrolysis of polysaccharides in birch and willow, but was less effective for acacia, eucalyptus, and poplar. The effectiveness of ammonia pretreatment increased with xylan content but decreased with lignin content of the hardwood species. This research presents that a delignification process is unnecessary for at least some hardwood biomass, such as birch, prior to enzymatic hydrolysis. Ammonia pretreatment should be effective to improve production of biofuels and biochemicals from hardwoods with high xylan and low lignin contents, such as birch and willow (Sakuragi, 2018).

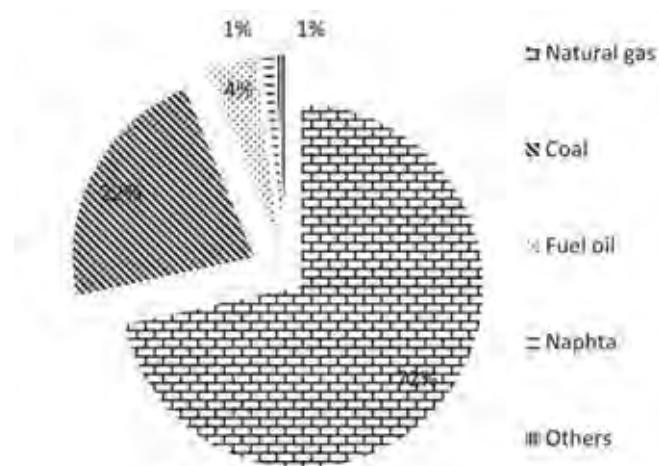
Valera-Medina et al., (2018) reviewed highlights previous influential studies and ongoing research to use ammonia as a viable energy vector for power applications. The review presented that the original applications of ammonia were in the chemical and agriculture industries and it still finds its greatest application as a fertilizer for intensive crop farming. However, in addition to its traditional applications, ammonia is an energetic chemical energy store with favorable physical properties, especially when compared to other chemical energy storage media (Valera-Medina, 2018).

Arda Yapicioglu, Ibrahim Dincer (2019) Modified from this review shown the uses of ammonia in various engine practical applications are Fuel cells, Spark ignition engines, Compression ignition engines, Gas turbines, Boilers, Generators, Refrigeration systems. Also, Ammonia is used as a fuel source in engines and fuel cells for this research purpose. The main finding of this review in the field regarding influence of ammonia in dual fuel combustion is increasing the amount of ammonia used, the exhaust temperatures and efficiency of the engine decrease. However, this

increase lead to a reduction in destructive emission which is the main motivation for the use of clean fuel sources for combustion (Yapicioglu and Dincer, 2019).

### 2.3 Feed Source of Ammonia, Urea

Ammonia can be produced from various feedstock such as naphtha, heavy fuel oil, coal, natural gas coke oven and refinery. Steam reforming of natural gas is the most used as feed source of ammonia production in the world, nearly 72% of ammonia production as represent in figure 2.2. The rest are coal, fuel oil, naphtha and others, respectively (Bicer, 2016).



**Figure 2.2** Feedstock sources of ammonia production in the world (Bicer,2016).

Cetinkaya et al., (2012) studied comprehensive life cycle assessment for five different methods of hydrogen generation including steam reforming of natural gas, coal gasification, water electrolysis via wind and solar, and thermochemical water splitting with a Cu-Cl cycle. They demonstrate that the most environmentally mind system is wind electrolysis-based hydrogen production, which is then followed by solar PV based electrolysis process. Both of the renewable energy methods can be utilized in suitable locations with low capacities (Cetinkaya, 2012).

Paul Gilbert et al., (2014) studied and assessed economically viable carbon reductions for the production of ammonia from biomass gasification. To reduce greenhouse gas emission from fertilizer, food supplies that support for growing population, biomass gasification are substituting natural gas reforming for ammonia production using techno-economic and life cycle assessment. The biomass 0.72 kg (35% moisture content) can produce 1 kg of syngas. It can be estimated that for 1 kg ammonia approximately 2.71 kg biomass (35% moisture content) is required (not considering biomass losses in the system). The assessment of economic illustrates that the biomass derived ammonia will be competing mainly with imported fossil fuel based ammonia. The cost of production of ammonia for both natural gas and biomass gasification systems is heavily influenced by the price of the feedstock, as well as by process scale. Producing ammonia from biomass gasification is economically viable at current biomass feedstock and ammonia prices, resulting in greenhouse gas reductions of 65% compared to conventional ammonia production from natural gas. Furthermore, the capital costs have high uncertainty to investor, lead to a very high risk investment (Gilbert, 2014).

Yusuf Bicer et al., (2016) present the result of comparative life cycle assessment of various ammonia production methods. They selected four different ammonia production methods for comparative assessment purposes. municipal waste-based ammonia production, nuclear high temperature-based ammonia production, biomass-based ammonia production, and hydropower-based ammonia production. They illustrate the energy efficiency for hydropower, nuclear high temperature, electrolysis, biomass-based electrolysis, and municipal waste-based electrolysis are calculated as 42.7%, 23.8%, 15.4%, and 11.7%, respectively. The exergy efficiencies of hydropower, nuclear, biomass and municipal waste-based ammonia production methods are yielded as 46.4%, 20.4%, 15.5% and 10.3%, respectively., respectively. They conclude that different resources-based ammonia production methods are thermodynamically analyzed and the energy and exergy efficiency values are comparatively assessed and renewable sources with their improved efficiency can reduce the overall environmental footprint. So, it can replace the current fossil fuel based centralized ammonia production facilities (Bicer, 2016).



2619937106

CU Theses 6173002063 thesis / recv: 20072563 10:48:08 / seq: 18



D. Frattini et al., (2016) researched a sustainable pathway for ammonia synthesis to reduce the use of fossil fuels of the Haber-Bosch process and, taking advantage of renewable sources. In field of use as a renewable energy system, hydrogen can be obtained from biomass gasification, biogas reforming or electrolysis of water with electricity generated by solar or wind energy. The Aspen Plus environment were used as the model development and operating parameters for simulations. The reactor block used to model units is “RGibbs” and the built-in NRTL property method is set as the thermodynamic model for the reforming and clean-up section. The authors reported that the model results are mainly in terms of gas and energy flows. Each of the three new concepts allows to produce ammonia in a novel way and simultaneously reducing the impact on the environment. This study demonstrates that ammonia can be produced in an efficient way from renewable using a thermochemical model developed in Aspen Plus (Frattini, 2016).

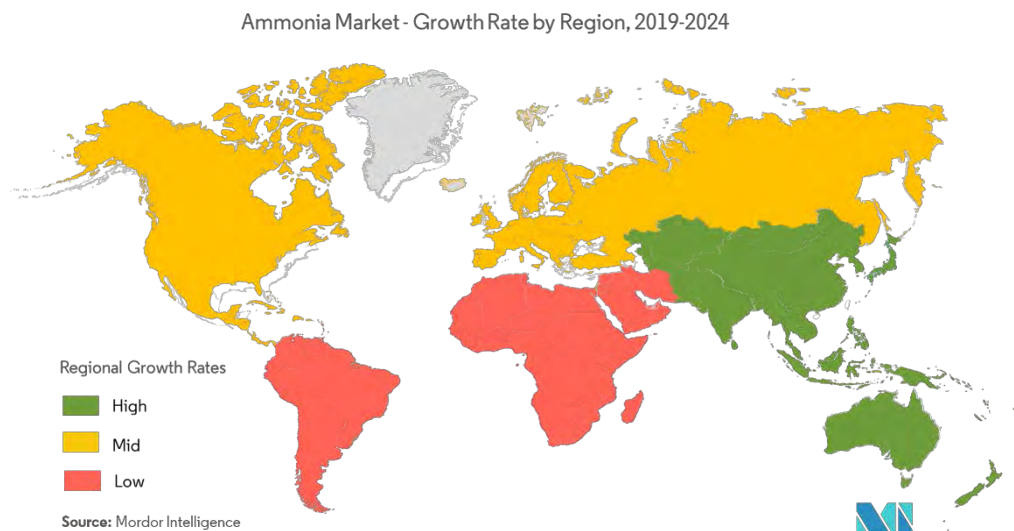
Maryam Akbari et al., (2018) studied the ammonia production from black liquor gasification and co-gasification with pulp and waste sludges. They investigated ammonia production through the gasification of three different feedstocks. The first case used black liquor, and in the other two cases pulp sludge and waste sludge are co-gasified with black liquor. The all of three cases process model in field of mass and energy balance were used to estimate the equipment size and estimate costs. The results indicated that ammonia production in all three cases cost decrease 10% competitive with current ammonia prices, there ranges from 743 to 748\$/ton. The result of techno-economic assessment show that the cost of production is most sensitive to the capital cost, discount rate, electricity price and plant lifetime (Akbari, 2018).

Dong Xiang, Yunpeng Zhou (2018) studied a new design and techno-economic performance of hydrogen and ammonia co-generation by coke-oven gas-pressure swing adsorption technology integrated with chemical looping hydrogen process. This concept design process has two extreme configurations to produce hydrogen or ammonia only. The optimization of coke-oven gas utilization and maximize hydrogen and subsequent ammonia production desire the analysis of key operational parameters of system. The maximal ammonia and hydrogen productions are 4,784 and 7,126 kmol/h of 5,532 kmol/h coke-oven gas consumption for the

extreme configurations, respectively. In this concept design process, switching between ammonia and hydrogen production have 68.5-73.6 % exergy efficiency and about 100% direct CO<sub>2</sub> efficiency. They also include the economic and sensitive analyses of this novel process in the studied (Xiang and Zhou, 2018).

## 2.4 The Market of Ammonia and Urea

In current, the demand in global market for fertilizer is rising modestly. In 2018, Asia-Pacific is the majority in ammonia market, accounting for more than half of the consumption globally. With the increasing population in countries such as China and India, increased agricultural activity has resulted in increased ammonia fertilizer usage, which will drive the market. China was the major consumer of ammonia in both the Asia-Pacific region and in the global market in 2018. Overall, the market for ammonia in Asia-Pacific region is anticipated to increasing significantly in the future (Intelligence, 2018).



**Figure 2.3** Ammonia Market – Growth Rate by Region, 2019-2024 (Mordor Intelligence, 2018).

From figure 2.3 that illustrate the growth rate of ammonia market by region. The forecast period is during 2019-2024 which have 3 regional growth rates.

### Global production rates

Ammonia production has become one of the most important industries in the world. From figure 2.4, ammonia production has increased steadily since 1946 and it is estimated that the annual production of ammonia is worth more than \$100 billion, with some plants producing more than 3,000 million ton per day of  $\text{NH}_3$ .



**Figure 2.4** Worldwide ammonia production has continued increased from 1946 to 2014. (AIChE The Global Home of Chemical Engineers, 2016).

Patricia M. Glibert et al., (2006) reported the escalating worldwide use of urea and global contributing to coastal eutrophication. The review has shown in field of demand that global rates of urea-base fertilizer usage have increased rapidly, so that more urea is now used than any other nitrogen fertilizer. Global urea usage extends beyond applications; urea is also used extensively in animal feeds and in manufacturing processes. The use of urea around the world is expected to continue with the potential to increase coastal waters pollution world-wide (Glibert, 2006).

Patricia Carneiro dos Santos, Alexandre S. Szklo (2016) researched about urea imports in Brazil and the increasing demand pressure from the biofuels industry and the role of domestic natural gas for the country's urea production growth. Brazil is a major producer of liquid biofuels. These high production level require to use of fertilizer, and to put the pressure on the nitrogen fertilizer domestic market. This contributes to increasing level of imports and trade shortage in the chemical industry. The findings show that Brazil will stay a major importer of urea. Urea associated with the production of biofuels has sufficient magnitude to justify an expansion of production capacity through a greenfield facility. this study estimated the associated urea demand for energy crops. The data shown average import prices for ammonia and urea in Brazil, 511.83 and 315.113 US\$ FOB/ton, respectively. However, the analysis of natural gas breakeven price to a greenfield urea project indicates that the project is not feasible (dos Santos and Szklo, 2016).

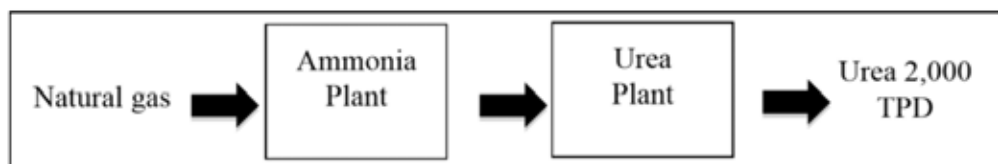
A Valera-Medina at al., (2018) reviewed highlights previous influential studies and ongoing research to use ammonia as a viable energy vector for power applications. The review shown that ammonia can be produced using renewable sources which not only contributes to reducing greenhouse emission, but also offers flexibility its utilization, allows fuel cells to be run effectively (using smaller, safer and economically viable configurations), enable combustion systems has the potential of operating at high power whilst producing tolerable levels of emissions, and enable advanced propulsion systems to be developed with smaller tanks. Thus, the ease of storages, transportation and use of ammonia make it an attractive candidate to act as the energy vector between sustainable energy harvesting and mobile and static energy demands (Valera-Medina, 2018).



2619937106

## 2.5 Ammonia and Urea Production

Several processes of ammonia and urea have been invented for optimum production rate and product specification including energy conservation. A HEN optimization is a network to minimize the energy requirement of a conceptual ammonia/urea plants. Therefore, this work is focused not only on the energy consumption analysis but also economic feasibility of processes. The capacity of conceptual ammonia and urea plant is 3,264 and 2,000 ton per day (TPD), respectively. The methane from natural gas is used as feedstock of the production. The overall production design is shown in figure 2.5.



**Figure 2.5** Overall production process for ammonia and urea plants.

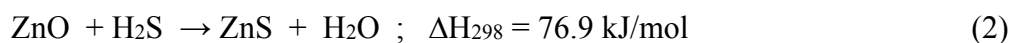
## 2.6 Ammonia Manufacturing Process

Ammonia is synthesized from hydrogen (from natural gas) and nitrogen (from the air). The operating condition is operated with high temperature about 450-500 °C and high pressure about 80-90 bar. The reaction mixture is cooled so that the ammonia liquefied and can be removed. The remaining nitrogen and hydrogen are recycled. Ammonia synthesis reaction is reversible. The overall reactions of ammonia production are shown as following equations.

**The main reaction:**

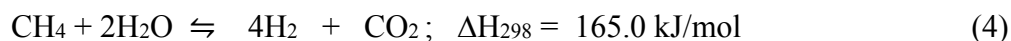
(Modak, 2002)

**Desulfurization unit:** to remove sulfur content. Natural gas contains some sulfurous compounds which damage the catalysts used in this process. These are removed by reacting them with zinc oxide, e.g.



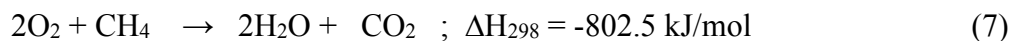
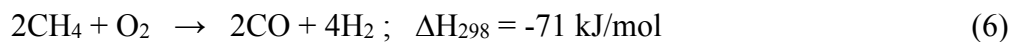
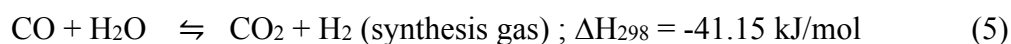
(Giuffrida, 2010)

**Primary reforming unit:** methane (sweet dry gas) is converted to hydrogen and carbon dioxide, the reactions are:



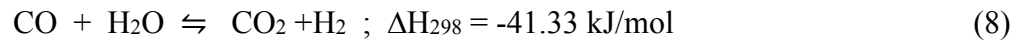
(Ochoa-Fernández, 2005)

**Secondary reforming unit:** hot air is added, the reactions are:



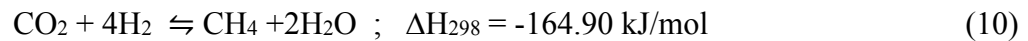
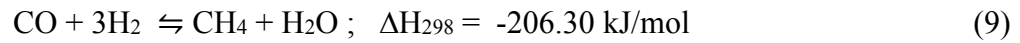
(Azzaro-Pantel, 2018)

**Shift conversion unit:** carbon monoxide is removed by water gas shift reaction. Carbon monoxide is converted to carbon dioxide.



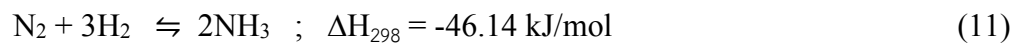
(Lin and Wu, 2020)

**Methanation unit:** all carbon oxides are converted to methane by following equations:



(Lin and Wu, 2020)

**Ammonia synthesis unit:** to produce final ammonia product



(Modak, 2002)

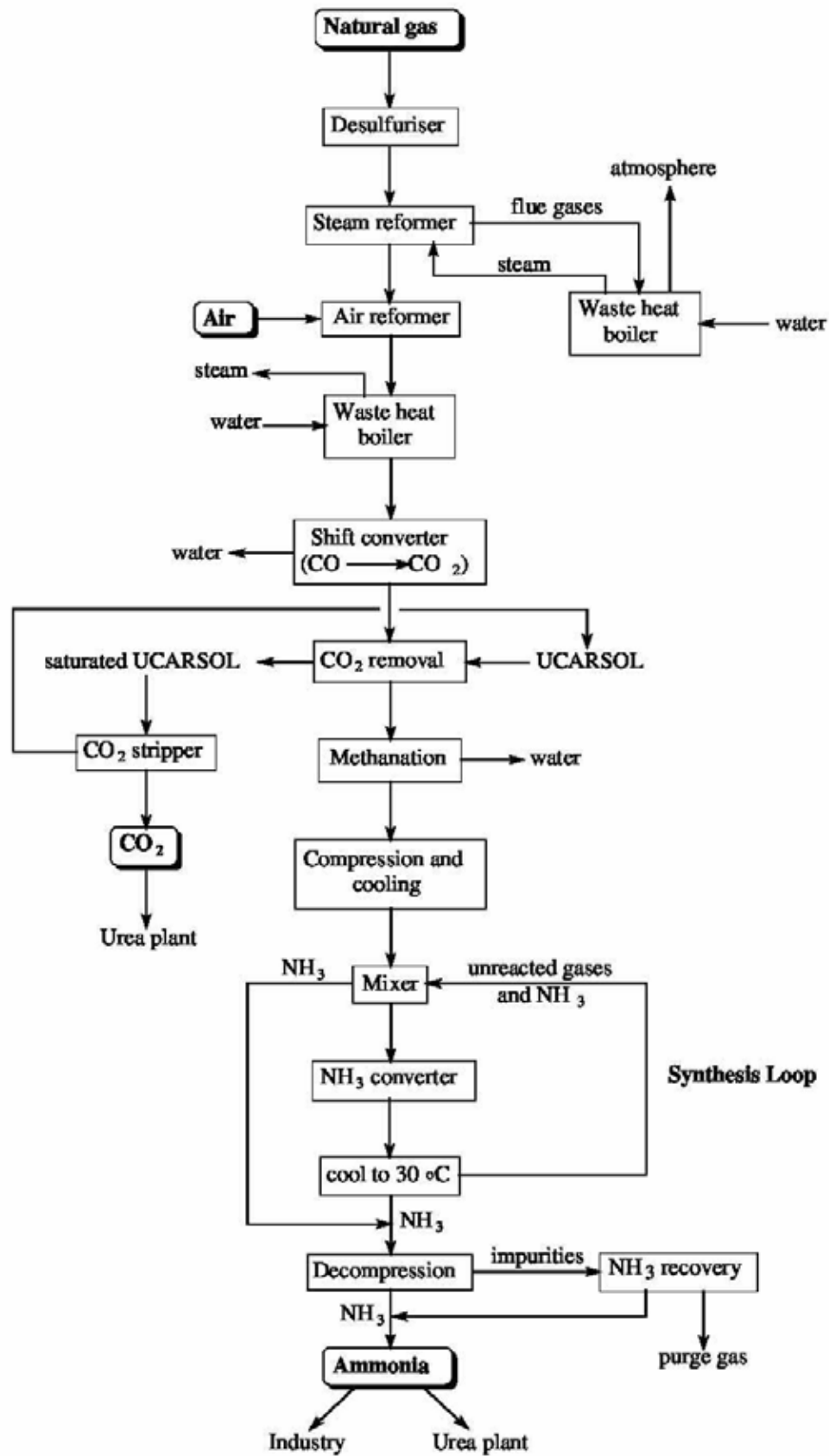


Figure 2.6 Schematic representation of the ammonia synthesis process (Coppelstone and Kirk, 2008).



The ammonia manufacturing process is shown schematically in figure 2.6.

### **Schematic description**

**Step 1 - Hydrogen production:** Hydrogen is produced by the reaction of methane with water. However, before this can be carried through, all sulfurous compounds must be removed from the natural gas to prevent catalyst damaging. These are removed by heating the gas to 400°C and reacting it with zinc oxide. The gas is sent to the primary reformer for steam reforming, where superheated steam is fed into the reformer with the methane. The gas mixture heated with natural gas and purge gas to 770°C in the presence of a nickel catalyst. The reaction converting the methane to hydrogen, carbon dioxide and small amount of carbon monoxide. This gaseous mixture is known as synthesis gas.

**Step 2 - Nitrogen addition:** The synthesis gas is cooled slightly to 735°C. It then flows to the secondary reformer where it is mixed with a calculated amount of air. The highly exothermic reaction between oxygen and methane produces more hydrogen. In addition, the necessary nitrogen is added in the secondary reformer.

**Step 3 - Removal of carbon monoxide:** Here the carbon monoxide is converted to carbon dioxide (which is used later in the synthesis of urea) in a reaction known as the water gas shift. This is achieved in two steps. Firstly, the gas stream is passed over a Cr/Fe<sub>3</sub>O<sub>4</sub> catalyst at 360°C and then over a Cu/ZnO/Cr catalyst at 210°C. The same reaction occurs in both steps but using the two steps maximizes conversion.

**Step 4 - Water removal:** The gas mixture is further cooled to 40°C, at which temperature the water condenses out and is removed.

**Step 5 - Removal of carbon dioxides:** The gases are then pumped up through a counter-current of UCARSOL™ solution. Carbon dioxide is highly soluble in this solution, and more than 99.9% of the CO<sub>2</sub> in the mixture dissolves in it. The remaining CO<sub>2</sub> is converted to methane (methanation) using a Ni/Al<sub>2</sub>O<sub>3</sub> catalyst at 325°C. The water which is produced in these reactions is removed by condensation at 40°C as above. The carbon dioxide is stripped from the UCARSOL and used in urea manufacture. The UCARSOL is cooled and reused for carbon dioxide removal.

**Step 6 - Synthesis of ammonia:** The gas mixture is now cooled, compressed and fed into the ammonia synthesis loop. A mixture of ammonia and unreacted gases which have already been around the loop are mixed with the incoming gas stream and cooled to 5°C. The ammonia present is removed, and the unreacted gases heated to 400°C at a pressure of 330 barg and passed over an iron catalyst. The outlet gas from the ammonia converter is cooled from 220°C to 30°C. This cooling process condenses more the half the ammonia, which is then separated out.

### 2.6.1 Ammonia Plant Design

Haldor-topsoe process is the process which depart form Haber's process. The residual gas of this process is wasted to atmosphere.

The advantages of this process are:

- It has a greater compactness, simplicity in case of converter design since under high-pressure gases have a smaller volume.
- This process is to eliminate expensive heat exchangers that are needed in processes that operate at low pressure.
- This process is removal of ammonia with water cooling alone.

The disadvantages of this process are:

- This process has a Shorter life of converters.
- High maintenance equipment in the high-pressure operation.
- There are about 20 % loss of gas production which is unconverted.

Haldor Topsoe process flow sheet of ammonia production is shown in figure 2.7

#### **Process important sections:**

1. Desulphurization Section
2. Reforming Section
3. CO Conversion Section
4. CO<sub>2</sub> Conversion Section
5. Methanation
6. Ammonia Synthesis Section
7. Refrigeration Section
8. Ammonia Absorption Section

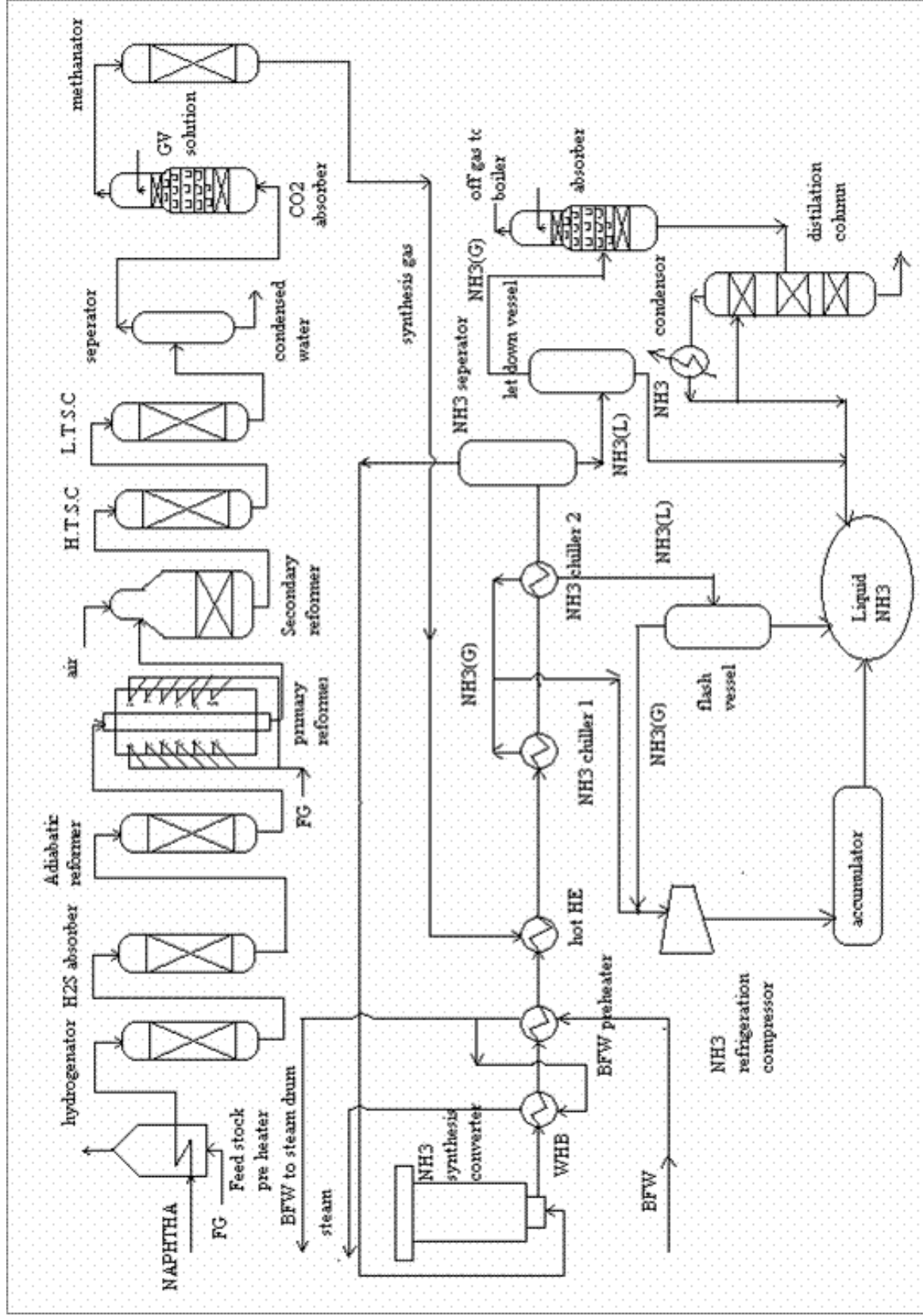


Figure 2.7 Haldor Topsoe Process Flow Sheet of Ammonia Production (Venkat Pattabathula, 2016).

Most of the global production of ammonia are produced from steam reforming of natural gas, significant quantities are produced by coal gasification; most of the gasification plants are in China.

The first commercial ammonia plant based on the Haber-Bosch process was built by BASF at Oppau, Germany with a production capacity of 30 million ton per day. The flow sheet of the first commercial ammonia plant by BASF is illustrated in figure 2.8.

### 2.6.2 Modern Production Processes

The demand for ammonia has increased considerably during the years 1950-1980, allowing plants to grow larger and save more energy.

In the mid-1960s, the American Oil Co. installed a single-converter ammonia plant engineered by M.W. Kellogg (MWK) at Texas City, TX, with a capacity of 544 million ton per day. The single-train design concept is illustrated in the figure 2.9.

Important differences between the MWK process and the processes used in previous ammonia plants included:

- using a centrifugal compressor as part of the synthesis gas compression
- maximizing the recovery of waste heat from the process
- generating steam from the waste heat for use in steam turbine drivers
- using the refrigeration compressor for rundown and atmospheric refrigeration.

Combined forms that use to balanced energy, energy production, equipment size and catalyst volume are combined throughout the plant.



2619937106

CU Theses 6173002063 thesis / rev: 20072563 10:48:08 / seq: 18

### 2.6.3 Plant Designs in the 21st Century

During the first few years of the 21st century, there were many improvements in ammonia technology that helped existing plants increase production rates and new plants to be built with larger and greater capabilities.

Most of the ammonia plants recently designed by KBR utilize its Purifier process (figure 2.10), which combines low-severity reforming in the primary reformer, a liquid N<sub>2</sub> wash purifier downstream of the methanator to remove impurities and adjust the H<sub>2</sub>:N<sub>2</sub> ratio, a proprietary waste-heat boiler design, a unitized chiller, and a horizontal ammonia synthesis converter. The energy consumption of this plant can be as low as 28 GJ per million ton. The primary reformer can be smaller than in conventional designs because the secondary reformer uses excess air.

The syngas generation section of a Haldor Topsøe-designed plant is quite traditional except for its proprietary side-fired reformer, which uses radiant burners to supply heat for the reforming reaction. More recent developments include the S-300 and S-350 converter designs. The S-300 converter is a three-bed radial-flow configuration with internal heat exchangers, while the S-350 design combines an S-300 converter with an S-50 single-bed design with waste-heat recovery between converters to maximize ammonia conversion. The Haldor Topsøe-designed plant is illustrated in figure 2.11.

The Linde Ammonia Concept (LAC) is an established technology process scheme with over 25 years of operating experience in plants with capacities from 200 million ton per day to over 1,750 million ton per day. The LAC process scheme, as shown in figure 2.12, replaces the expensive and complex front end of a conventional ammonia plant with two well-proven, dependable process units:

- production of ultra-high-purity hydrogen from a steam-methane reformer with PSA purification
- production of ultra-high-purity nitrogen by a cryogenic nitrogen generation unit, also known as an air separation unit (ASU).

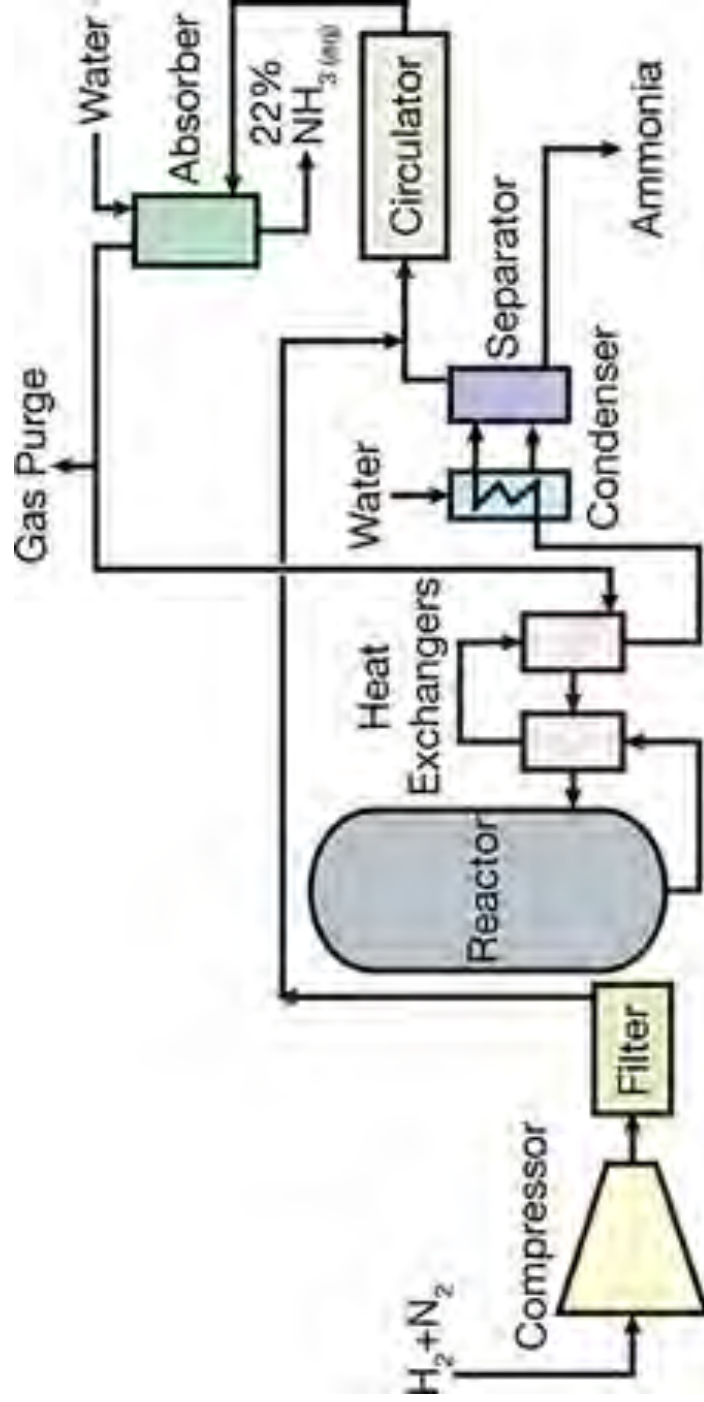


Figure 2.8 A simplified flowsheet of the first commercial ammonia plant by BASF (Venkat Pattabathula, 2016).

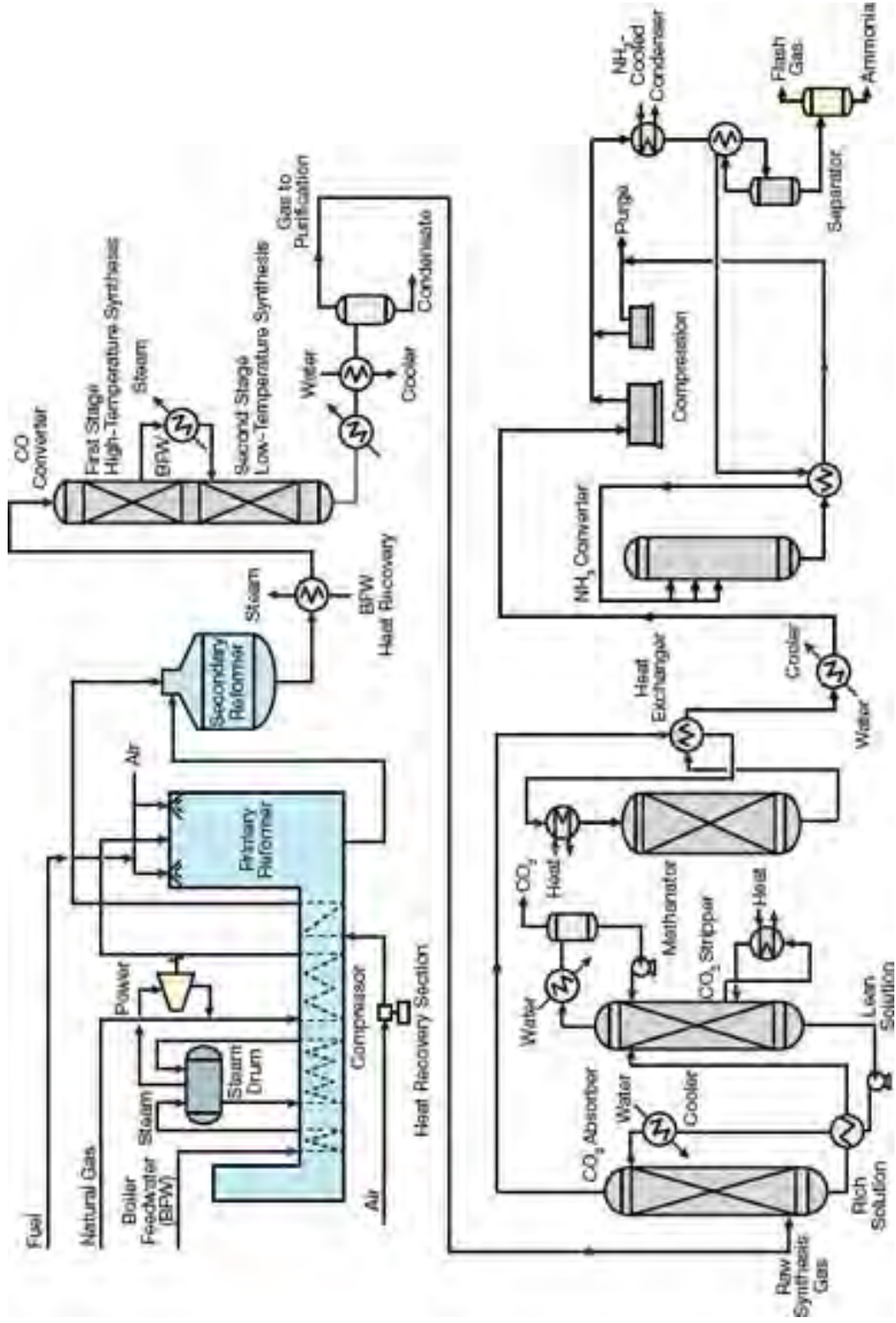
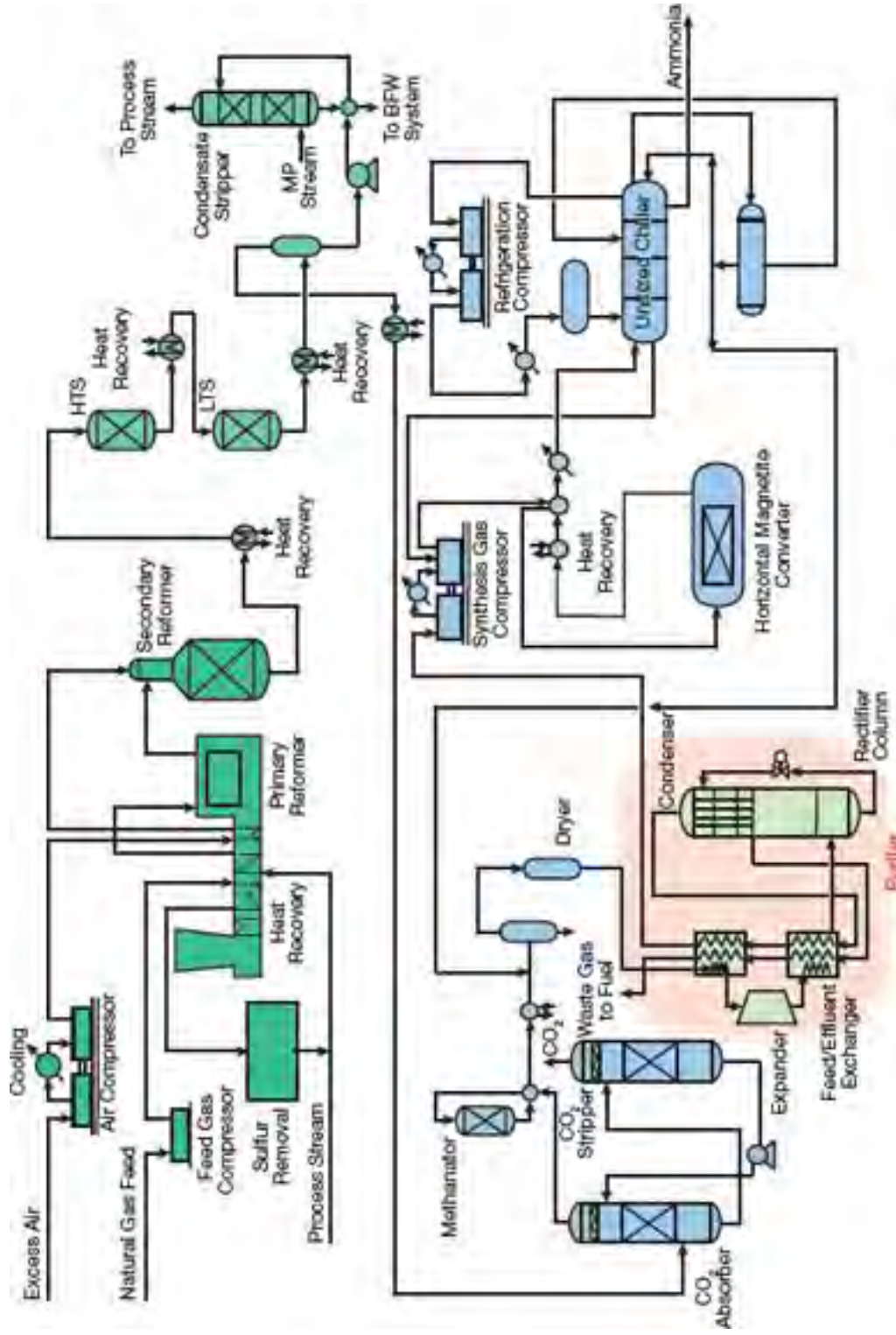
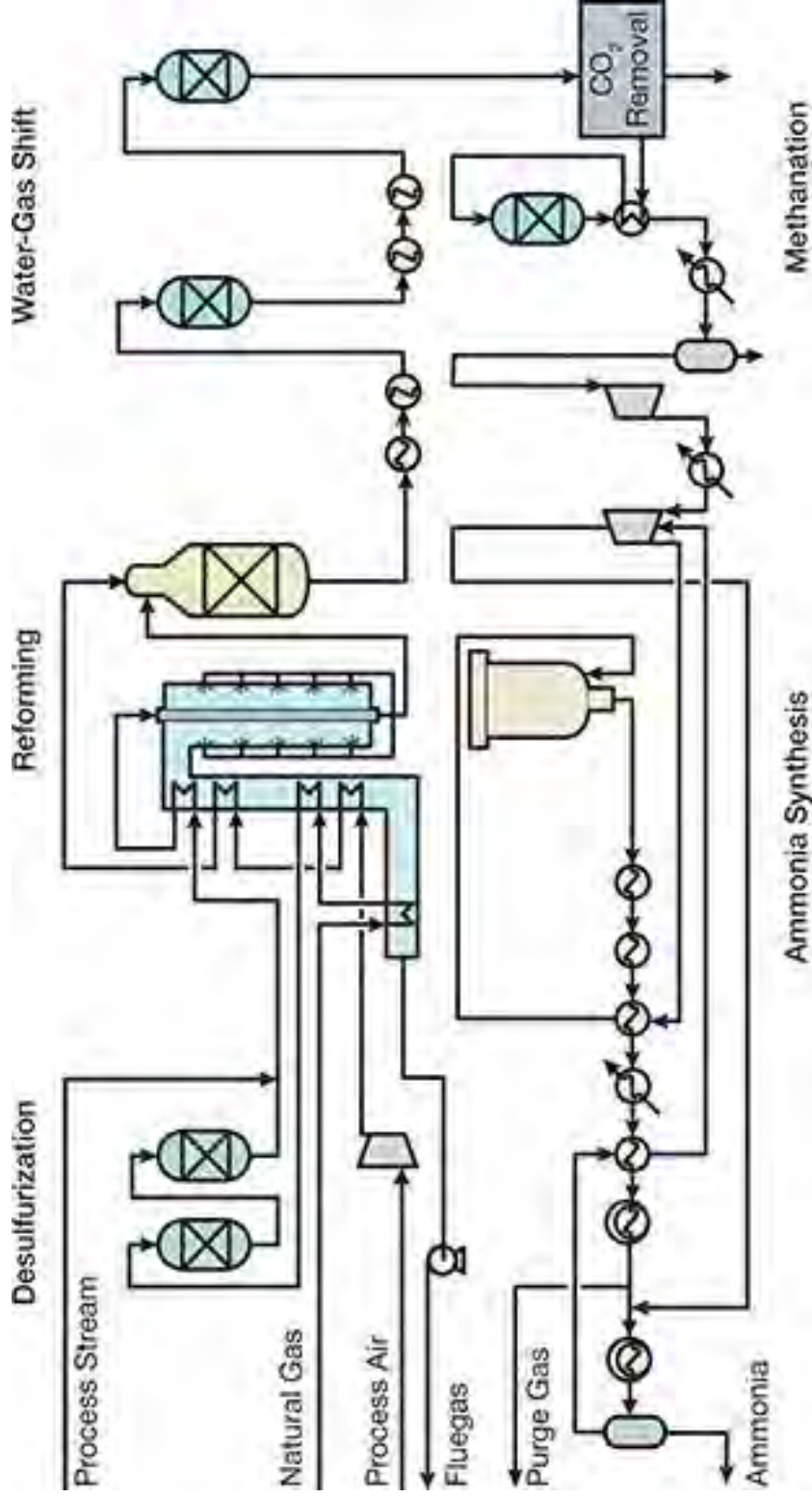


Figure 2.9 KBR designed one of the first single-train, large-capacity ammonia plants (Venkat Pattabathula, 2016).

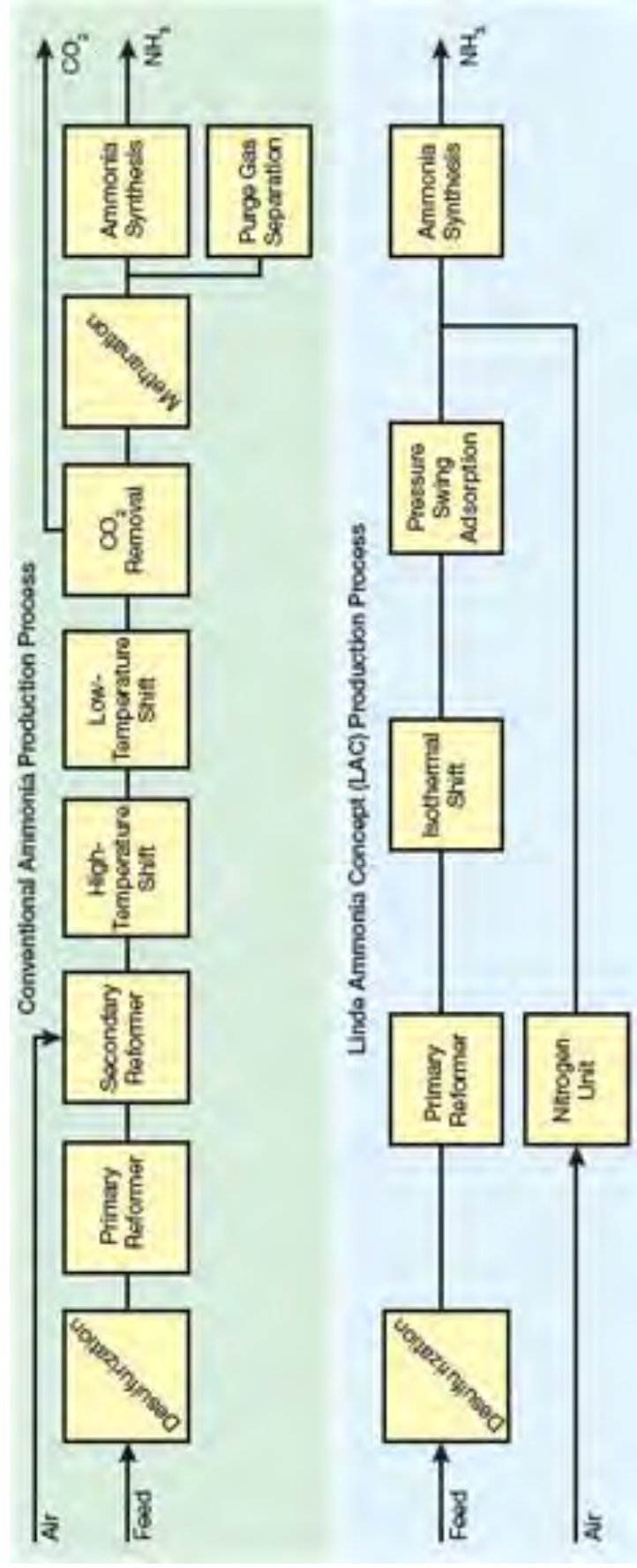


**Figure 2.10** Modern ammonia plants designed by KBR employ its proprietary Purifier design (Venkat Pattabathula, 2016).





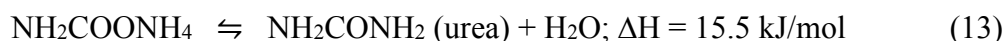
**Figure 2.11** Haldor Topsøe offers an ammonia plant design that has a proprietary side-fired reformer in which radiant burners supply heat for the reforming reaction (Venkat Pattabathula, 2016).



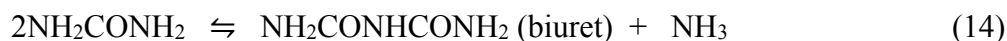
**Figure 2.12** The Linde Ammonia Concept (LAC) features a pressure-swing adsorption unit for high-purity hydrogen production and an air separation unit for high-purity nitrogen production (Venkat Pattabathula, 2016).

## 2.7 Urea Manufacturing Process

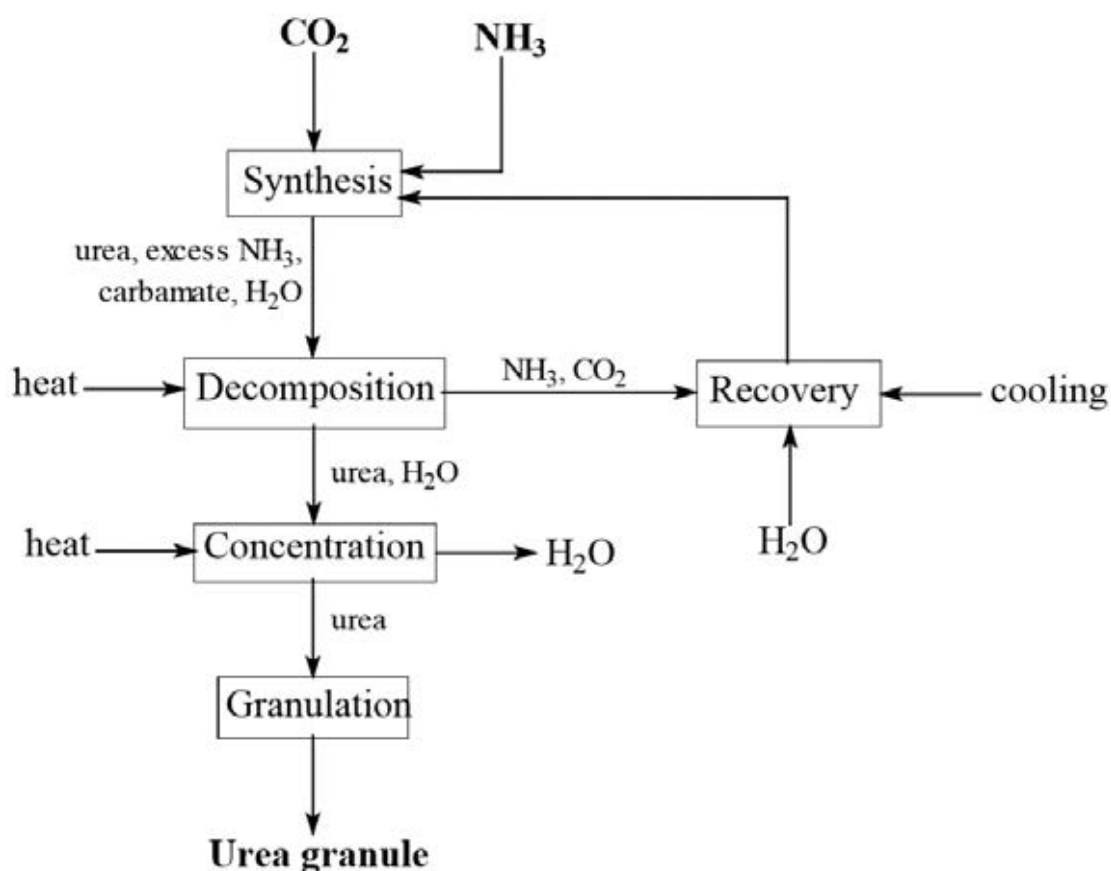
As mentioned above, most of the ammonia is used on site in the production of urea. The remainder is sold domestically for use in industrial refrigeration systems and other applications that require anhydrous ammonia. The urea is used as a nitrogen-rich fertilizer, and as such is of great importance in agriculture, one of world's major industries. There are two main equilibrium reactions in the urea synthesis. The first reaction is highly fast exothermic in which ammonia and carbon dioxide are converted to ammonia carbamide. The second reaction is slow endothermic. The operating condition is operated at high pressure 20-25 bar with temperature 150-220 °C. Urea is produced from ammonia and carbon dioxide in two equilibrium reactions:



The urea manufacturing process, shown schematically in Figure 2.13, is designed to maximize these reactions while inhibiting biuret formation:



This reaction is undesirable, not only because it lowers the yield of urea, but because biuret burns the leaves of plants. This means that urea which contains high levels of biuret is unsuitable for use as a fertilizer.



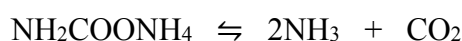
**Figure 2.13** Schematic representation of urea synthesis (Coppelstone and Kirk, 2008).

This reaction is undesirable, not only because it lowers the yield of urea, but because biuret burns the leaves of plants. This means that urea which contains high levels of biuret is unsuitable for use as a fertilizer.

### Schematic description

**Step 1 – Synthesis:** A mixture of compressed  $\text{CO}_2$  and ammonia at 240 barg is reacted to form ammonium carbamate. This is an exothermic reaction, and heat is recovered by a boiler which produces steam. The first reactor achieves 78% conversion of the carbon dioxide to urea and the liquid is then purified. The second reactor receives the gas from the first reactor and recycle solution. Conversion of carbon dioxide to urea is approximately 60% at a pressure of 50 barg.

**Step 2 – Purification:** The major impurities in the mixture at this stage are water from the urea production reaction and unconsumed reactants (ammonia, carbon dioxide and ammonium carbamate). The unconsumed reactants are removed in three stages. Firstly, the pressure is reduced from 240 to 17 barg and the solution is heated, which causes the ammonium carbamate to decompose to ammonia and carbon dioxide:



At the same time, some of the ammonia and carbon dioxide flash off. The pressure is then reduced to 2.0 barg and finally to -0.35 barg, with more ammonia and carbon dioxide being lost at each stage. By the time the mixture is at -0.35 barg a solution of urea dissolved in water and free of other impurities remains. At each stage the unconsumed reactants are absorbed into a water solution which is recycled to the secondary reactor. The excess ammonia is purified and used as feedstock to the primary reactor.

**Step 3 – Concentration:** 75% of the urea solution is heated under vacuum, which evaporates off some of the water, increasing the urea concentration. At this stage some urea crystals also form. The solution is then heated from 80 to 110°C to dissolve these crystals prior to evaporation. In the evaporation stage molten urea (99% w/w) is produced at 140°C. The remaining 25% of the 68% w/w urea solution is processed under vacuum at 135°C in a two series evaporator-separator arrangement.

**Step 4 – Granulation:** Urea is sold for fertilizer as 2 - 4 mm diameter granules. These granules are formed by spraying molten urea onto seed granules which are supported on a bed of air. This occurs in a granulator which receives the seed granules at one end and discharges enlarged granules at the other as molten urea is sprayed through nozzles. Dry, cool granules are classified using screens. Oversized granules are crushed and combined with undersized ones for use as seed. All dust and air from the granulator are removed by a fan into a dust scrubber, which removes the urea with a water solution then discharges the air to the atmosphere. The final product is cooled in air, weighed and conveyed to bulk storage ready for sale (Coppelstone and Kirk, 2008).

### Conventional Process – urea production from natural gas

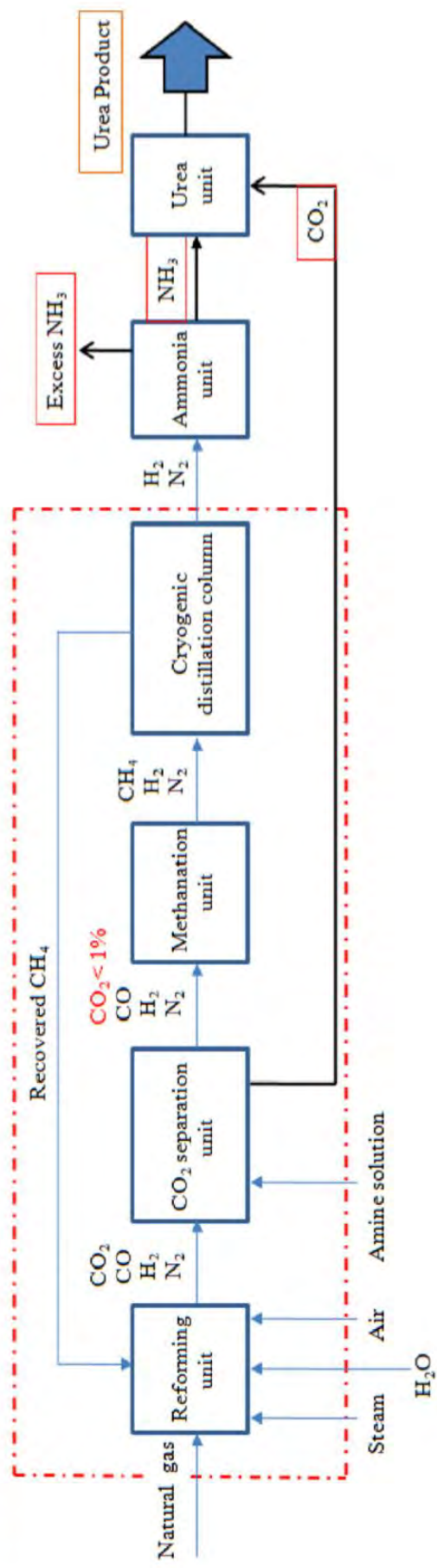


Figure 2.14 Scheme of the conventional process for urea production from natural gas (Edrisi, 2016).



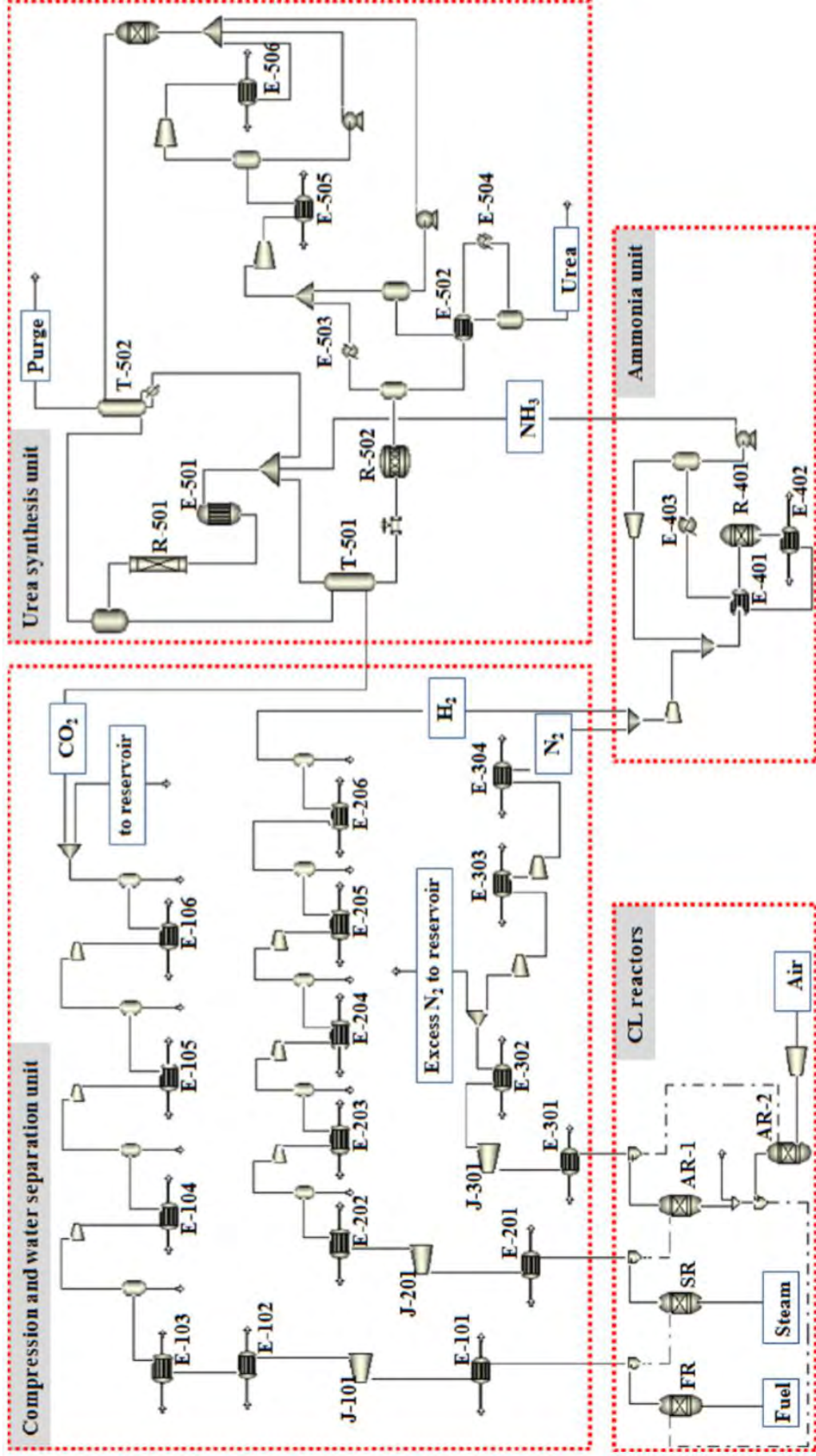
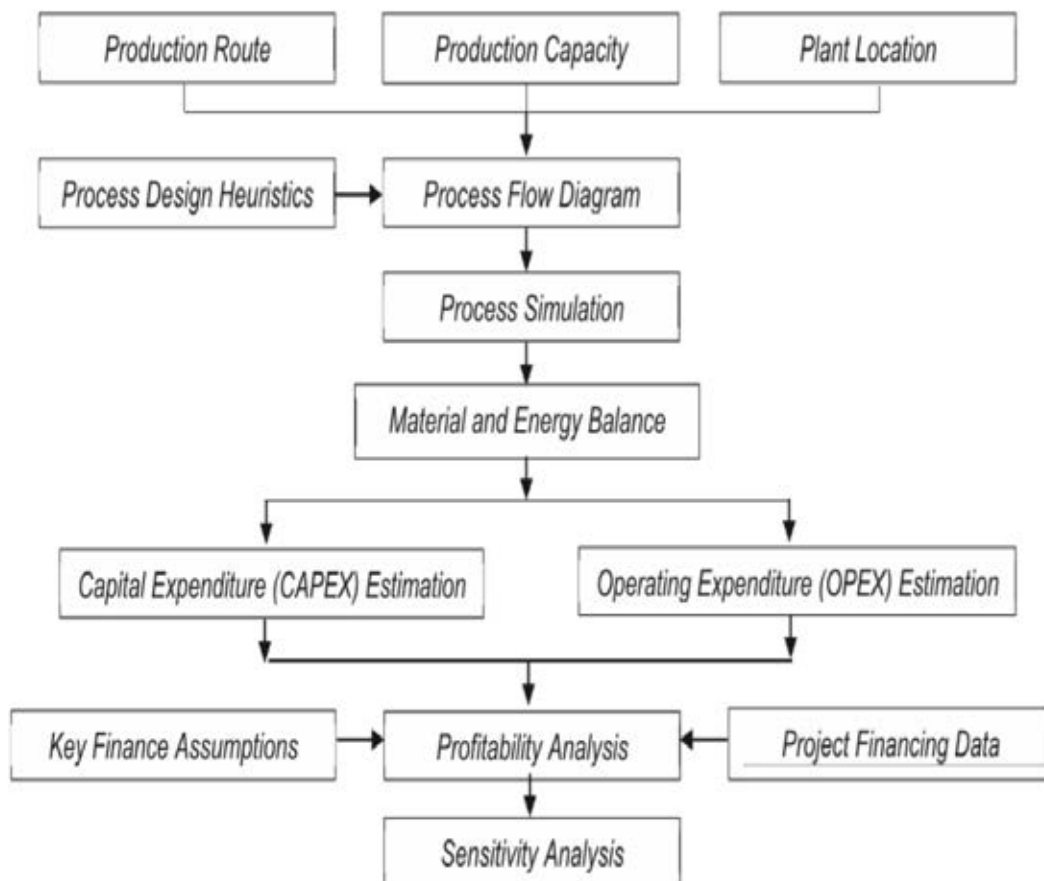


Figure 2.15 Proposed plant for urea production using chemical looping process (before heat and power integration) (Edrisi, 2016).

## 2.8 Techno-Economic Analysis (TEA)

Techno-Economic model is an integration of technological research and commercial development involves engineering process design with economic feasibility. Also, it is a key of financial evaluation to provide investment and marketing. In this work is focused on 2 main parts. First part is simulation since production route until material and process validation. Second part is economic analysis which mainly represents the capital expenditure, the operating expenditure, net present value, and payback period. The overall hierarchical approach that used as a base-case model to design and to develops the final production is shown in figure 2.16.



**Figure 2.16** Overall methodology approach for techno-economic analysis (Cheah, 2017).



### 2.8.1 Capital Expenditure (CAPEX) Estimation

Capital expenditure represents a property, plant, equipment, and services that will be used for more than one year. This cost includes mainly purchasing process equipment, hardware purchases, vehicles and associates with constructing the plant includes investing activities.

### 2.8.2 Operating Expenditure (OPEX) Estimation

Operating expenditure represents a necessary expense of a business which incurs through its normal operations to keep the business running on a daily basis. This cost includes rent, utilities, salaries, equipment, inventory costs, marketing, general, & administrative expenses, property taxes, payroll, insurance, research expenses, and development.

### 2.8.3 Profitability Analysis

Profitability analysis is used to determine the amount of profit earned due to the efficiency of any operation. This technique helps in a financial decision, marketing and product management for a company.

### 2.8.4 Sensitivity Analysis

In this work, a definition of sensitivity analysis is a technique used to identify a differently independent variables which impacts to the main dependent variables. For example; production rate, stream/methane ratio, feed temperature/pressure of each reactors, synthesis loop pressure, and conversion percentage. For ammonia and urea processes, these variables are used to consider on the plant feasibility.

For cost index is used the most common one which is from IHS CERA index. The equipment costs were estimated using a guide to chemical engineering process design and economics book as shown below

Present cost = (capital cost index in 2019/capital cost index in 2000) x previous cost

### 2.8.5 Equipment Design and Cost Estimation

Calculation of equipment cost is based on material and energy balance, operation condition, material handling. Estimating equipment costs are represented as the following equations.

#### 2.8.5.1 *Reactor*

In this simulation work, Reactor is based on residence time of 60 s. The purchased cost formulation is shown as the following equations (Seider, 2004)

$$V_R = 1.25T_R \times Q \quad (15)$$

$$C_{\text{reactor}} = 14000 + 15400V_R^{0.7} \quad (16)$$

Where  $V_R$  is the reactor volume in  $\text{m}^3$ ,  $Q$  is the volumetric flow rate in  $\text{m}^3/\text{s}$  and  $T_R$  is residence time in s.

#### 2.8.5.2 *Flash Drum*

The purchased cost of flash drum is formulated as the following equations (Seider, 2004)

$$V_F = QT_F \quad (17)$$

$$C_F = 12685V_F^{0.3641} \quad (18)$$

Where  $V_F$  is the flash drum volume in  $\text{m}^3$ ,  $Q$  is the volumetric flow rate in  $\text{m}^3/\text{s}$  and  $T_F$  is the fixed residence time in s.

### 2.8.5.3 Distillation Column

The purchased cost of distillation column is calculated as the following equations (Seider, 2004)

$$A_n = 0.5V_m(\rho_v)^{0.5} \quad (19)$$

$$D_c = (4A_n)^{0.5} (0.88\pi)^{-0.5} \quad (20)$$

$$H_c = 1.2(N-1)T_s \quad (21)$$

$$C_{DC} = 4555 H_c^{0.81} - D_c^{1.05} \quad (22)$$

Where  $H_c$  is height of the column in m,  $D_c$  is diameter of the column in m,  $N$  is the number of trays,  $T_s$  is the tray spacing in m (assume 1 m),  $A_n$  is the net activate area,  $\rho_v$  is the vapor mass density, and  $V_m$  is the vapor mass flow rate.

### 2.8.5.4 Centrifugal Pump

The purchased cost of Centrifugal Pump is calculated as the following equations (Seider, 2004)

$$S = Q(H)^{0.5} \quad (23)$$

$$C_p^0 = 5.4 \exp(9.7171 - 0.6019[\ln(S)] + 0.0519[\ln(S)]^2) \quad (24)$$

Where  $Q$  is the volumetric flow rate in the range of 0.2-500 L/s,  $H$  is the pump head in feet of fluid flowing.

### 2.8.5.5 Compressor

The purchased cost of carbon-steel centrifugal compressors are calculated by using following equation (Seider, 2004)

$$C_{com}^0 = 8400 + 3100 P^{0.6} \quad (25)$$

Where  $P$  in driver power ranges from 132 to 29,000 kW.

#### 2.8.5.6 Fired Heater

The purchased cost of stainless-steel fired heater with maximum heat pressure of 5000 KPa can be calculated by using following equation (Seider, 2004)

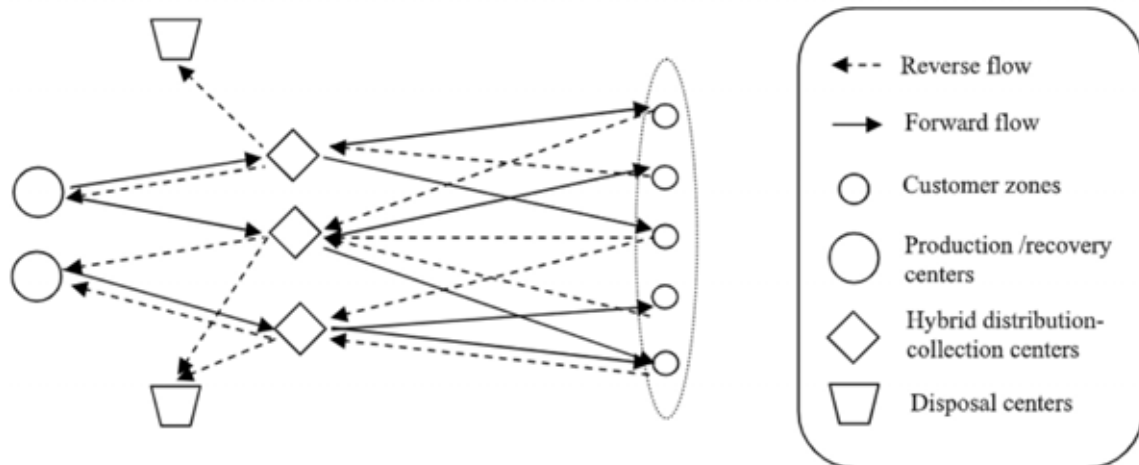
$$C_{FH}^0 = 184967 HD^{0.7636} \quad (26)$$

Where HD is the heat duty in MW

### 2.9 Stochastic Model

Stochastic analysis is a basic tool in much of modern probability theory and is used in many applied areas from biology to physics, especially statistical mechanics. It has become particularly well known via the Black-Scholes formula as a way of modelling financial markets and strategies. Stochastic programming model also be used in logistics network design under uncertainty. One of the most important and strategic issues in supply chain management is the configuration of the logistics network that has a significant effect on the total performance of the supply chain.

Mir Saman Pishvaei et al. (2009). They developed a stochastic and optimization model for integrated forward and reverse logistics network design under uncertainty. This study proposes a scenario-based stochastic optimization model. The model used hybrid distribution, collection facilities that offer cost savings and pollution reduction because of sharing material handling equipment and infrastructure. The uncertainty in the quality of returned products is modeled by considering the share of recoverable and scrapped products in the returns as a stochastic parameter. Computational results showed that the stochastic model could handle data uncertainty with a reasonable increase in total costs compared with the deterministic model.



**Figure 2.17** Structure of integrated forward/reverse logistics network (Pishvae, 2009).

Figure 2.17 demonstrates the structure of integrated logistics network. With this strategy, excessive transportation of returned products (especially scrapped products) is prevented and the returned products can be shipped directly to the appropriate facilities (Pishvae, 2009).

## CHAPTER 3 EXPERIMENTAL

### 3.1 Materials and Equipment

#### 3.1.1 Equipment

a. Computer Desktop model : ASUSTek Computer Inc. Intel® Core™ i7 6700K CPU @4.0GHz, 32 GB of RAM, Windows 10 ©2018 Microsoft Corporation. (64-bit Operating system)

b. Computer laptop model : ASUS TUF fx505GE Intel® Core™ i7-8750H CPU @2.2GHz, 8GB of RAM, Windows 10 ©2018 Microsoft Corporation. (64-bit Operating system)

#### 3.1.2 Softwares

- a. Simsci Pro II Version 10.0
- b. GAMS
- c. Microsoft office excel

### 3.2 Objectives and Scope of Research Work

#### 3.2.1 Objectives

a. To design conceptual process of ammonia and urea plant with maximum capacity from 1,930 TPD of natural gas feed.

b. To analyze energy consumption of the process and economic feasibility for industrial case.

c. To estimate capital expenditure (CAPEX) and operating expenditure (OPEX) of ammonia and urea plants.

d. To optimize supply chain of ammonia and urea from uncertainty data of markets' demand with stochastic model analysis.

### 3.2.2 Scope of Research Work

- a. This research is focused on assessment of the energy consumption and economic feasibility to achieve the optimum condition with the capacity of 3,000 TPD of ammonia plant and 5,000 TPD of urea plant.
- b. The feedstock of the ammonia plant is considered only methane from natural gas.
- c. The simulation software Pro II was determined the results in this experiment.
- d. The stochastic optimization for supply chain of ammonia and urea will be done.

## 3.3 Methodology

### 3.3.1 Simulation for Ammonia and Urea Manufacturing Processes

- a. Input flow rate, temperature, pressure, reactions of all streams into process by using Pro II software.
- b. Apply more utility units design by Pro II software.
- c. Analysis of total energy consumption and economic feasibility for industrial case.

### 3.3.2 Investment Expenditures of Ammonia and Urea Plants Assessment

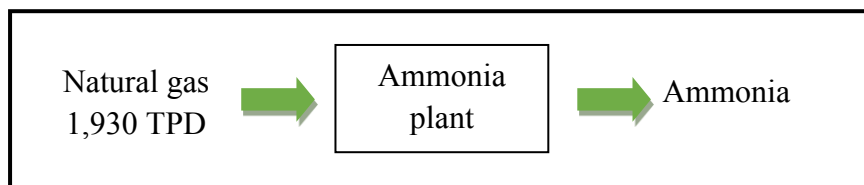
- a. Calculate capital expenditure (CAPEX) and operating expenditure (OPEX).
- b. Calculate net present value and payback period.
- c. Profitability analysis.
- d. Sensitivity analysis.

### 3.3.3 Case Studies

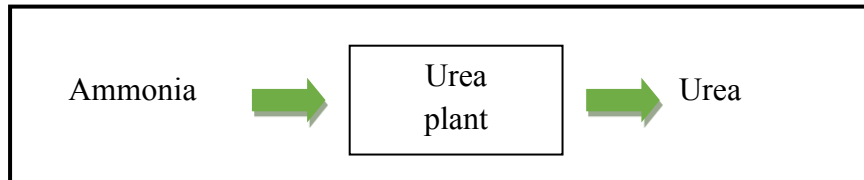
- a. Simulation and energy assessment part, there are two cases: 1. Ammonia plant and 2. Urea plant.
- b. Economic feasibility part, there are three cases: 1. ammonia plant, 2. urea plant, and 3. Combination case (ammonia and urea plants).

c. Optimization for transportation part, there are two cases: c1. The stochastic analysis for the supply chain with fixed production rate of ammonia and urea. c2. The stochastic analysis for the supply chain with varied production rate of Ammonia and Urea.

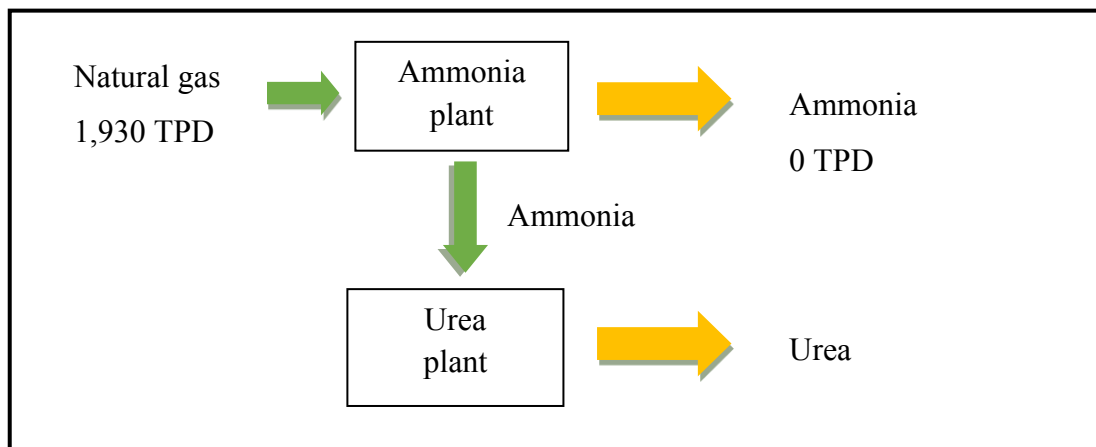
Case 1: Ammonia plant. (Maximum production capacity of ammonia from 1,930 TPD natural gas feed).



Case 2: Urea plant. (Maximum production capacity of urea from feed of ammonia product in case1)

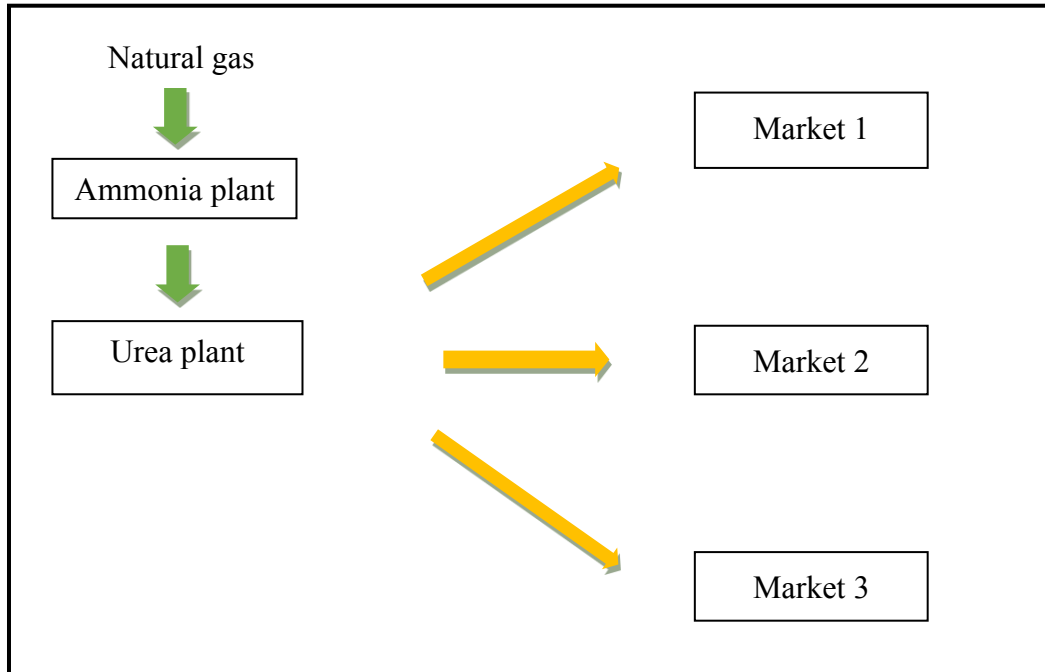


Case 3: Combination case (Maximum production capacity of urea from 1,930 TPD of natural gas feed).

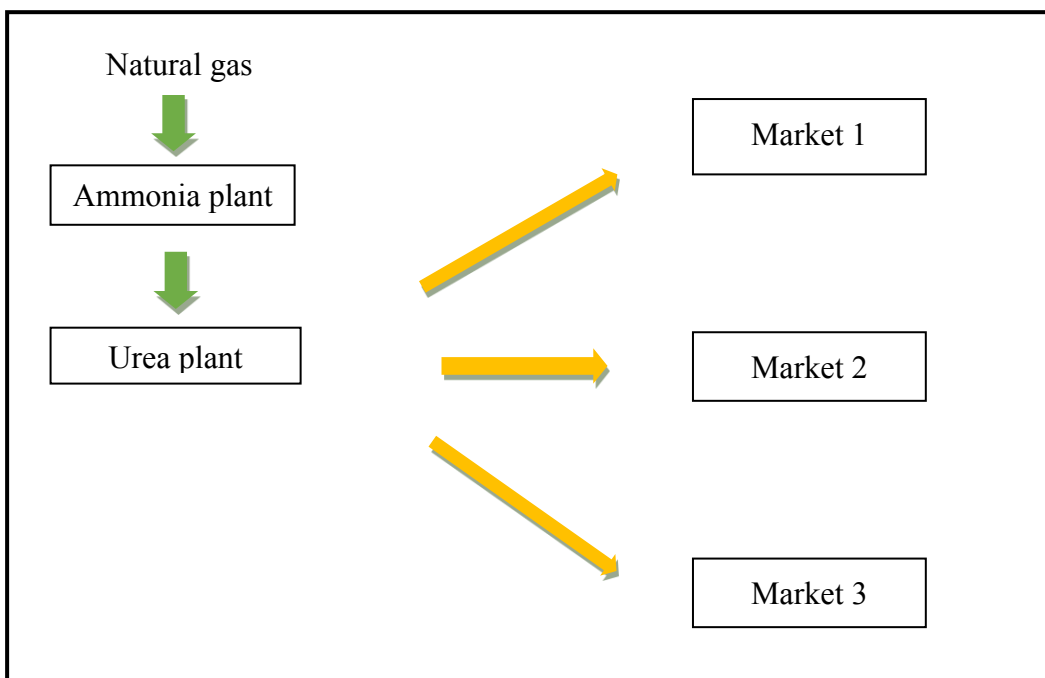




Case c1: Ammonia and Urea plant with improved deterministic and stochastic supply chain optimization under fixed production rate of ammonia and urea.



Case c2: Ammonia and Urea plant with improved deterministic and stochastic supply chain optimization varied production rate of ammonia and urea.



## CHAPTER 4 RESULTS AND DISCUSSION

### 4.1 Properties and Specification for Simulation Processes – Ammonia Plant

This research proposes the ammonia and urea synthesis process by the PROII software to simulate workflow and estimate the energy consumption. The main feedstock of the process is 1,930 ton per day of natural gas. The ammonia production of the conceptual process is 3,870 ton per day. The carbon dioxide eliminated from gas sweetening process is about 5,202 ton per day and consumed in the urea synthesis process about 4,986 ton per day. The properties and specification of natural gas feedstock, steam feed, air feed, and water make up are shown in the table 6.1, 6.2, 6.3, and 6.4, respectively. The ammonia product specifications are shown in the table 6.5. The input data of the conceptual ammonia manufacturing are shown in the table 6.6.

Table 4.1 Compositions of natural gas feed

Condition: Temperature 15.556°C, Pressure 340 psia and Flow rate of 1,930 TPD

Natural gas feed	
Component	% mole
Carbon dioxide	0.028496
Nitrogen	2.105208
Methane	97.471142
Ethane	0.394549
Propane	0.000605
Flow rate (ton/day)	1,930

Table 4.2 Properties of steam feed

Condition: Temperature 510°C, Pressure 334 psia and Flow rate of 3,224 TPD

Steam feed	
Component	% mole
H <sub>2</sub> O	100
Flow rate (ton/day)	3,224

Table 4.3 Properties of air feed

Condition: Temperature 25°C, Pressure 180 psia and Flow rate of 7,517 TPD

Air feed	
Component	% mole
Oxygen	21
Nitrogen	78.1
Argon	1
Flow rate (ton/day)	7,517

Table 4.4 Properties of water make up

Condition: Temperature 25°C, Pressure 15 psia and Flow rate of 2,852 TPD

Water make up	
Component	% mole
H <sub>2</sub> O	100
Flow rate (ton/day)	3,224

Table 4.5 Ammonia production specification

Ammonia product	
Ammonia purity (% mole)	99.3%
Flow rate (ton/day)	3,870
Temperature (°C)	-27.04
Pressure (psia)	4,450

Table 4.6 Input data of ammonia process

Reaction Name		Desulfurization
Reaction type		Isothermal
Reaction		$\text{ZnO} + \text{H}_2\text{S} \rightarrow \text{ZnS} + \text{H}_2\text{O}$ ; $\Delta\text{H} = - 206.30 \text{ kJ/mol}$
Basis		Flash drum DESULFER
Temperature = 393.33 °C		Reaction phases Vapor
Pressure = 334 psia		Pressure drop 2 psi
Reaction Name		Primary Reforming
Reaction type		Gibbs Reactor
Reaction		$\text{CH}_4 + 2\text{H}_2\text{O} \rightarrow 4\text{H}_2 + \text{CO}_2$ ; $\Delta\text{H} = - 165.0 \text{ kJ/mol}$
Basis Reactor No.RX1		Base component Methane
Temperature = 880 °C		Reaction phases Vapor phase
Pressure = 334 psia		
Reaction Name		Primary Reforming
Reaction type		Gibbs Reactor
Reaction		$\text{CH}_4 + \text{H}_2\text{O} \rightleftharpoons 3\text{H}_2 + \text{CO}$ ; $\Delta\text{H} = +206.30 \text{ kJ/mol}$
Basis Reactor NO.RX1		Base component Methane
Temperature = 880 °C		Reaction phases Vapor phase
Pressure = 334 psia		
Reaction Name		Secondary Reforming
Reaction type		Gibbs Reactor
Reaction		$\text{CO} + \text{H}_2\text{O} \rightleftharpoons \text{CO}_2 + \text{H}_2$ ; $\Delta\text{H} = -41.15 \text{ kJ/mol}$
Basis Reactor No.RX2		Base component Methane
Temperature = 1,340 °C		Reaction phases Vapor phase
Pressure = 180 psia		

Reaction Name		Secondary Reforming	
Reaction type		Gibbs Reactor	
Reaction		$O_2 + 2CH_4 \rightarrow 2CO + 4H_2$ ; $\Delta H = -35.98$ kJ/mol	
Basis Reactor No. RX2	Base component	Methane	
Temperature = 1,340 °C	Reaction phases	Vapor phase	
Pressure = 180 psia			
Reaction Name		High Temperature Shift Conversion	
Reaction type		Equilibrium Reactor	
Reaction		$CO + H_2O \rightleftharpoons CO_2 + H_2$ ; $\Delta H = -41.33$ kJ/mol	
Basis Reactor No. HTSR	Base component	Carbon monoxide	
Temperature = 140 °C	Reaction phases	Vapor phase	
Pressure = 176 psia			
Reaction Name		Low Temperature Shift Conversion	
Reaction type		Equilibrium Reactor	
Reaction		$CO + H_2O \rightleftharpoons CO_2 + H_2$ ; $\Delta H = -41.33$ kJ/mol	
Basis Reactor No. LTSR	Base component	Carbon monoxide	
Temperature = 80 °C	Reaction phases	Vapor phase	
Pressure = 176 psia			
Reaction Name		Ammonia Conversion	
Reaction type		Equilibrium Reactor	
Reaction		$N_2 + 3H_2 \rightleftharpoons 2NH_3$ ; $\Delta H = -92$ kJ/mol	
Basis Reactor No. RX3	Base component	Hydrogen	
Temperature = 336 °C	Reaction phases	Vapor phase	
Pressure = 4,470 psia	Equilibrium data	A = -32.975 B = 22930.4 (Pro II data base)	

## 4.2 Process Flow Diagram – Case 1 Ammonia Manufacturing Process

Natural gas, temperature 15°C pressure 340 psia and flow rate of 1,930 ton per day, was fed into the process simulation. The ammonia manufacturing process from the software has 3,870 ton per day productivity of Ammonia. The process is divided into 4 stage: 1. Catalytic reforming stage, 2. Shift conversion and sweetening stage, 3. Compression stage, and 4. Conversion stage. The product specifications are temperature -27 °C, pressure 4,470 psia and purity of 99.90 %. This simulation had been developed by Commercial software Pro II program version 10.0 which was used in ammonia manufacturing process. SRK thermodynamic model was used to achieve the ammonia specification product more accurately.

### 4.2.1 A Conceptual Design of Ammonia Production – Stage 1 Catalytic Reforming

Catalytic reforming is a chemical synthesis for product syngas (hydrogen and carbon monoxide) from natural gas and steam. The purpose of catalytic reforming is to produce hydrogen. The catalytic reforming in the simulation has consist of 2 main reaction; primary reforming and secondary reforming. The primary reformer, methane is combined with steam to be reformed to hydrogen and carbon monoxide including carbon dioxide is occurred. In the secondary stream reformer, hot air is added. The catalytic reforming stage is illustrated in Figure 4.1.

### 4.2.2 A Conceptual Design of Ammonia Production – Stage 2 Shift Conversion and Gas Sweetening

Shift conversion or water gas shift reaction is a reaction of carbon monoxide and water vapor to form hydrogen and carbon dioxide. Shift conversion has 2 section; High temperature shift reaction (HTSR) and Low temperature shift reaction (LTSR). Afterward, these gases are sent to sweetening section to remove carbon dioxide from the stream. In the sweetening section, AMINE01 thermodynamic model from the software was used to achieve the specification product more accurately. The specification of this section is to control operating condition to reach 0.2-0.5mol% CO and 0.005-0.2% CO<sub>2</sub>. The removal carbon dioxide then be sent to the Urea

manufacturing process. The shift conversion and gas sweetening stage is shown in Figure 4.2.

#### 4.2.3 A Conceptual Design of Ammonia Production – Stage 3 Compression

The purified synthesis gas is compressed in a three stages unit to achieve the proper pressure to produce ammonia in the next stage. Very high pressure, about 4,400 psia, is required to produce ammonia. The aftercooler is installed to control raising temperature from compression stage. The compression stage is represented in Figure 4.3.

#### 4.2.4 A Conceptual Design of Ammonia Production – Stage 4 Conversion

The conversion stage is a reaction of hydrogen and nitrogen with high pressure to form ammonia. From stoichiometry, 3 mole of hydrogen and 1 mole of nitrogen are mixed to form 2 mole of ammonia. The specifications of the product from simulation are 3,870 ton per day of flow rate with 99.90 % purity, -27 °C of temperature, and 4,450 psia of pressure. The ammonia conversion stage is represented in Figure 4.4.



2619937106

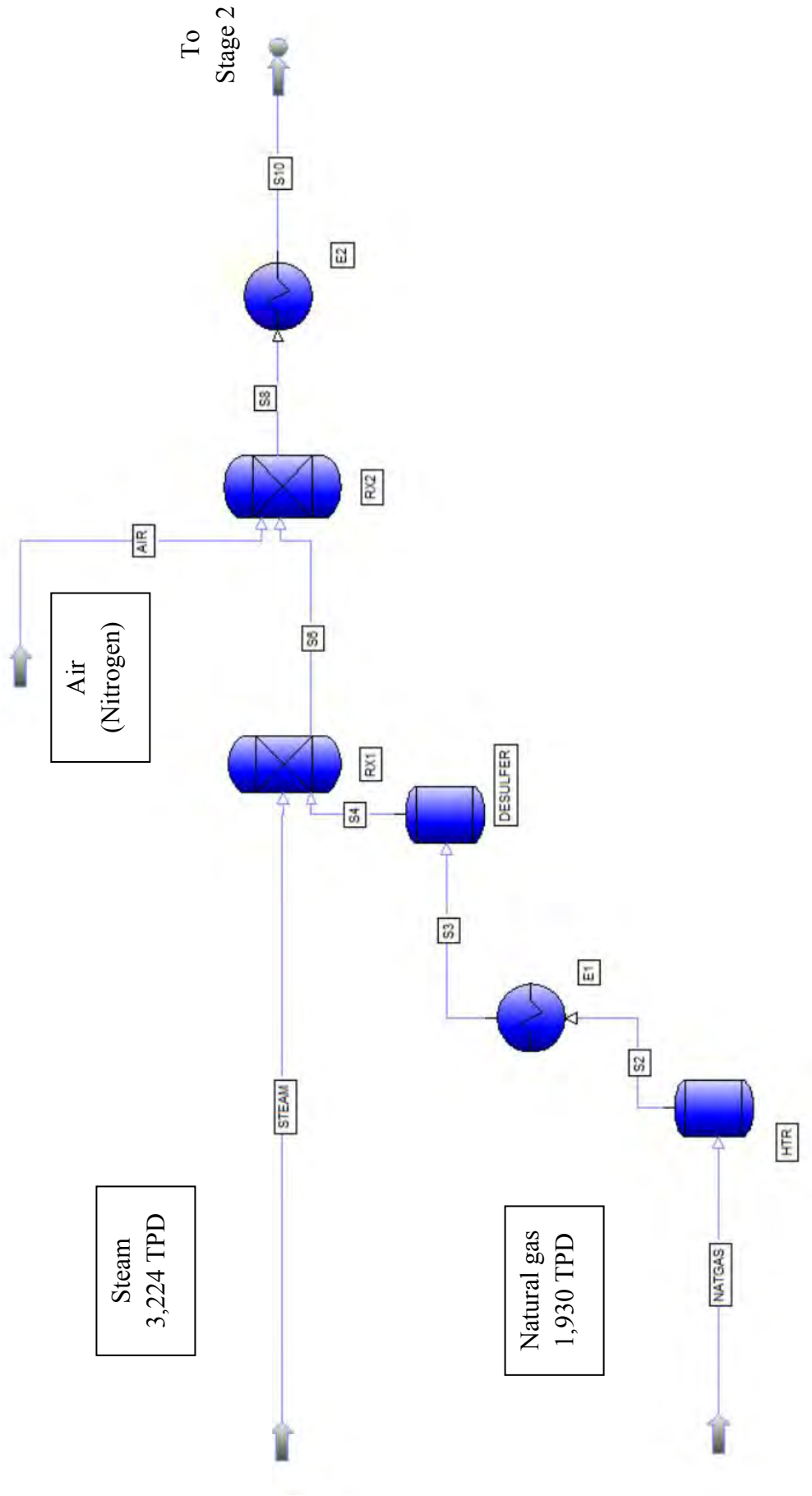


Figure 4.1 The simulation of ammonia production – stage 1 Catalytic reforming.



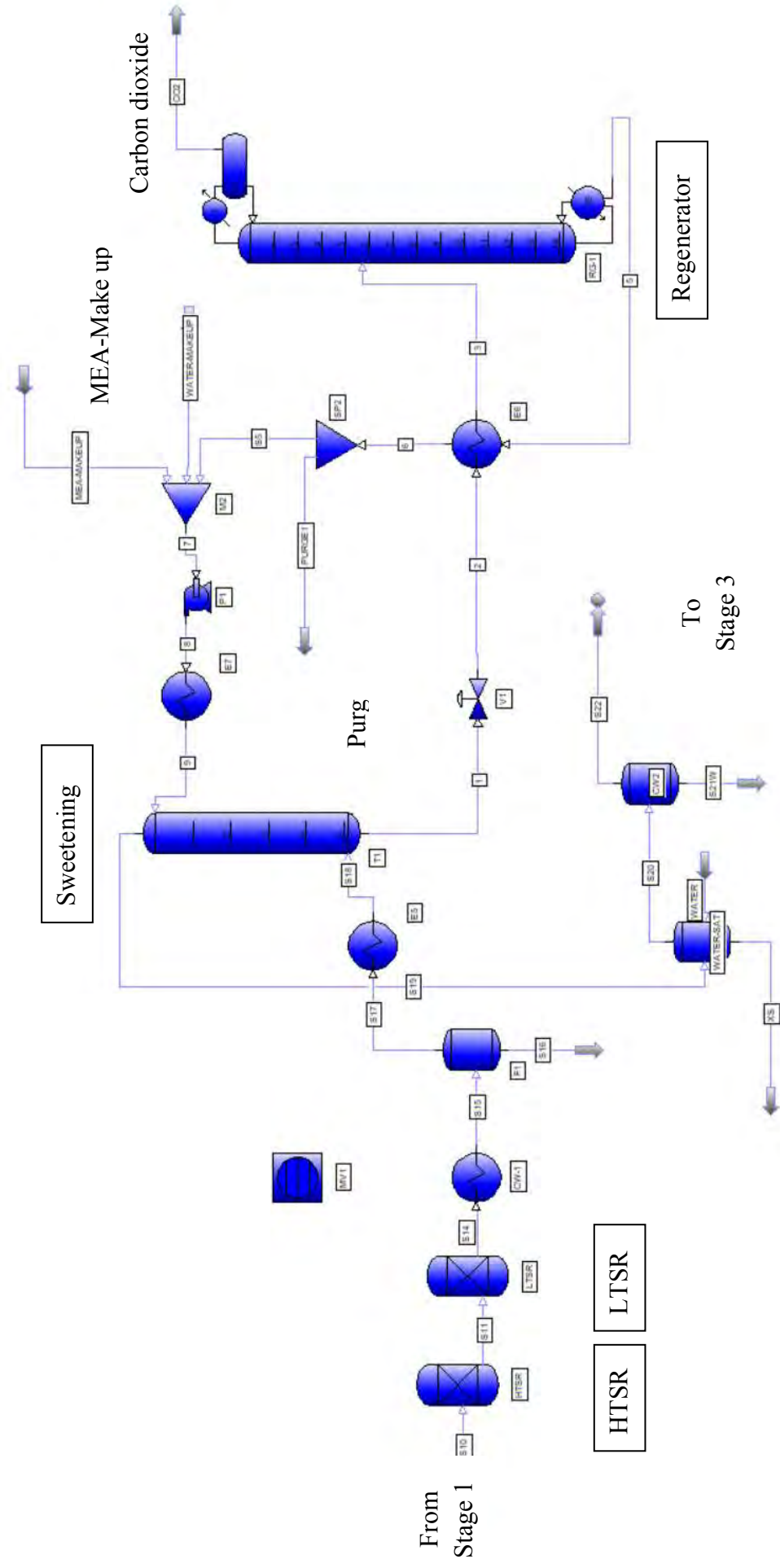


Figure 4.2 The simulation of ammonia production – stage 2 shift conversion and gas sweetening.

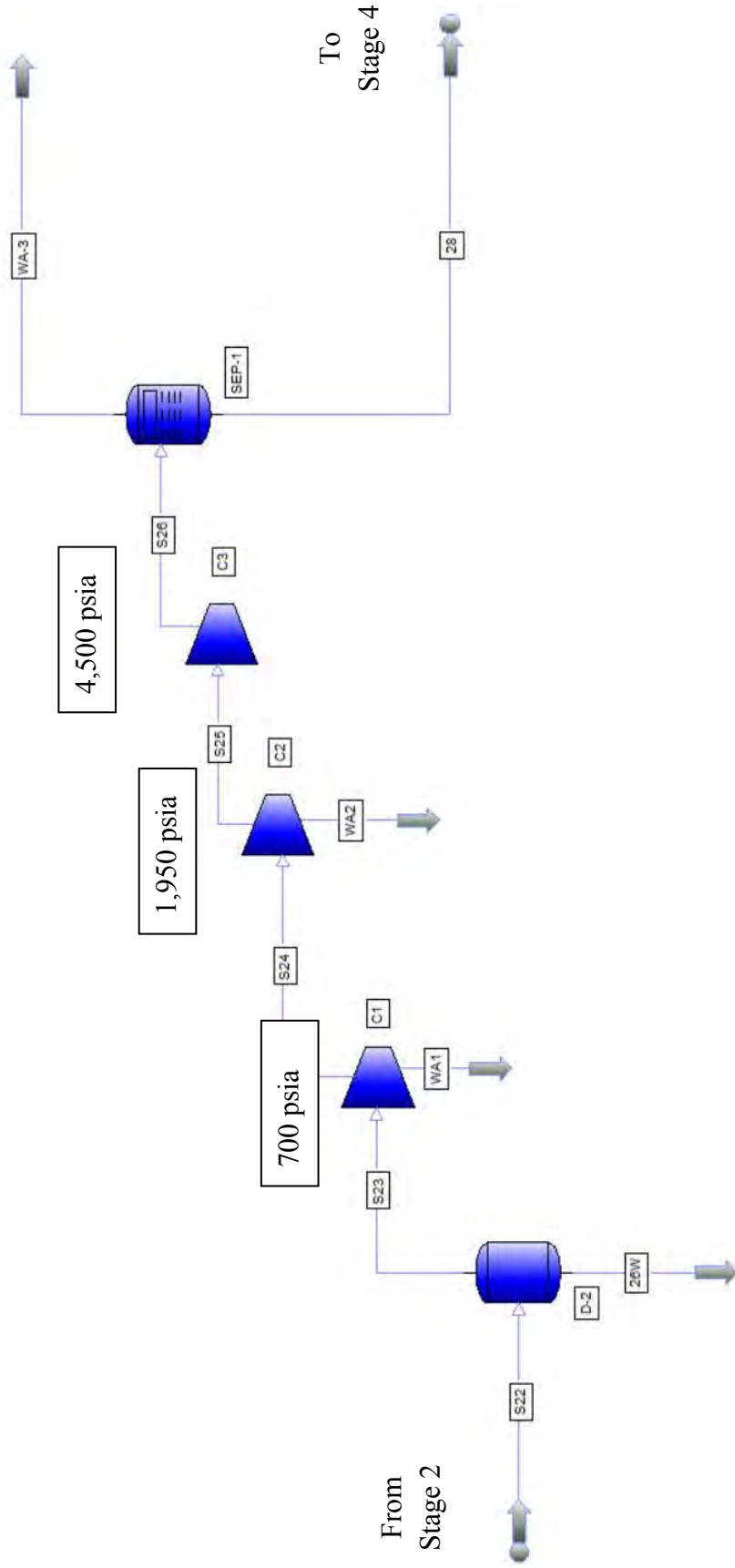


Figure 4.3 The simulation of ammonia production – stage 3 compression.

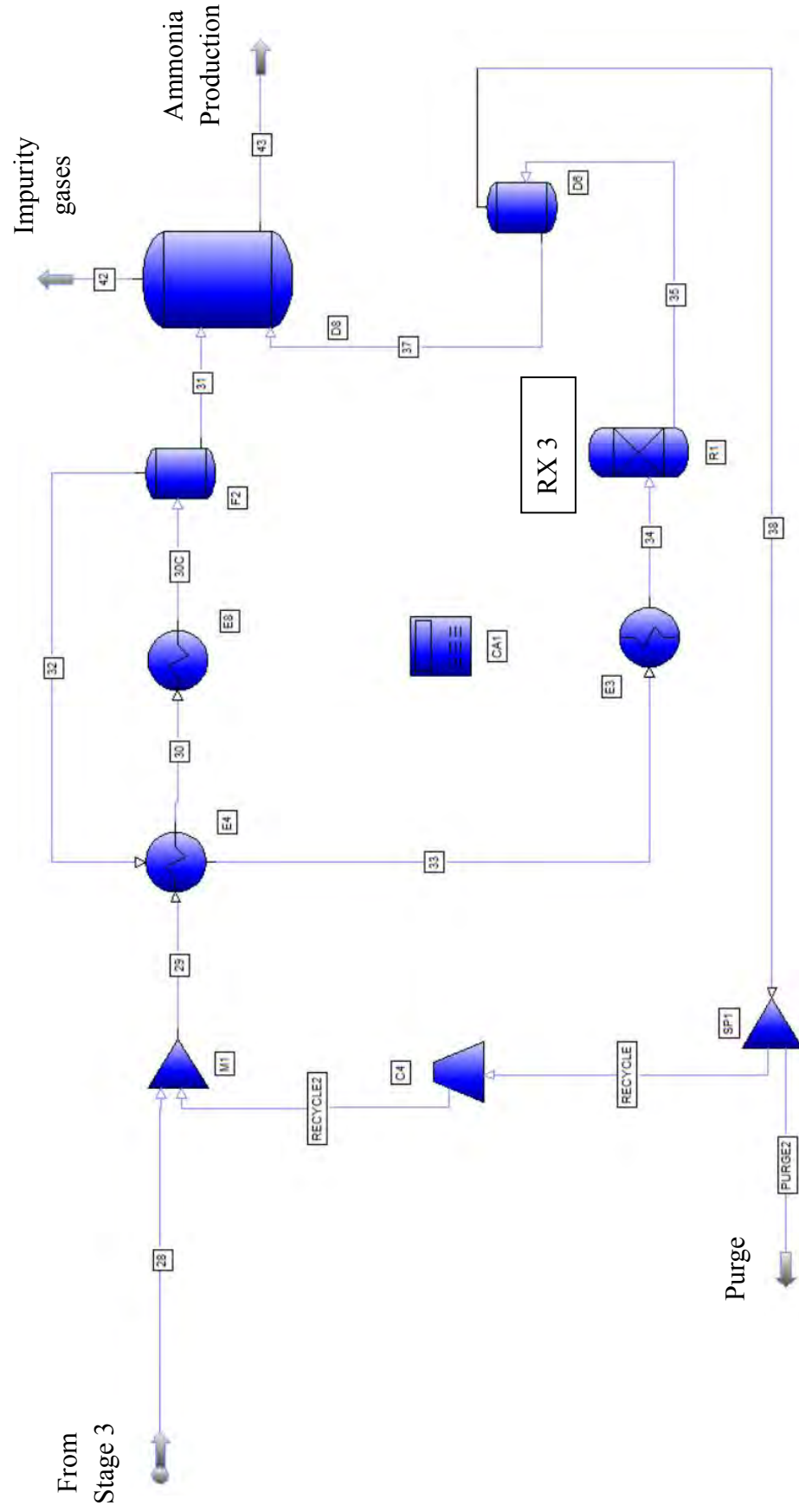


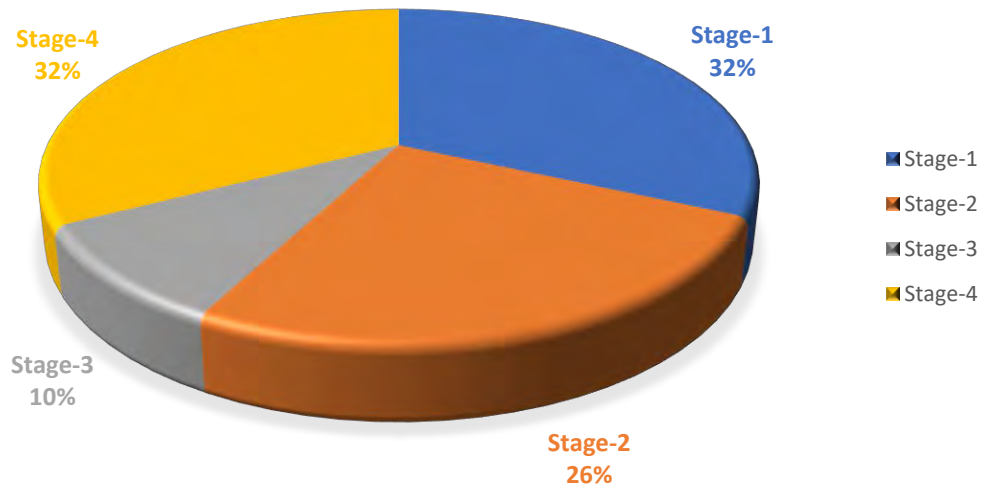
Figure 4.4 The simulation of ammonia production – stage 4 ammonia conversion.

### 4.3 Energy Consumption Analysis – Ammonia Manufacturing Process

The ammonia manufacturing process, stage 1 is Catalytic reforming. This stage consists of 5 units. The hot utility consumes energy about  $8.7184 \times 10^7$  kJ/hr. The cold utilities consume energy of  $1.0504 \times 10^9$  kJ/hr. Stage 2 is Catalytic shift and gas sweetening. This stage consists of 15 units. The hot utilities consume energy about  $1.9088 \times 10^9$  kJ/hr. The cold utilities consume energy about  $2.1646 \times 10^9$  kJ/hr. Stage 3 is Compression. This stage consists of 5 units and there is no energy consumption of hot utilities. The cold utilities consume energy about  $3.4445 \times 10^8$  kJ/hr. The shaft work from compressor is about  $9.49 \times 10^4$  kW. Stage 4 is Ammonia conversion. This stage consists of 10 units. The hot utilities consume energy about  $2.4292 \times 10^8$  kJ/hr. The refrigerant utilities consume energy about  $9.2539 \times 10^8$  kJ/hr. The Urea synthesis process consists of 21 units. The hot utilities consume energy of  $3.6204 \times 10^8$  kJ/hr. The cold utilities consume energy about  $4.6607 \times 10^8$  kJ/hr. The shaft work is about  $8.49 \times 10^4$  kW. For ammonia manufacturing process, total energy consumption in stage 1 catalytic reforming, stage 2 shift conversion and gas sweetening, stage 3 compression, and stage 4 ammonia conversion are shown in the figure 29, 30, 31, and 32 respectively.

**Table 4.7** Overall energy consumption for ammonia manufacturing process

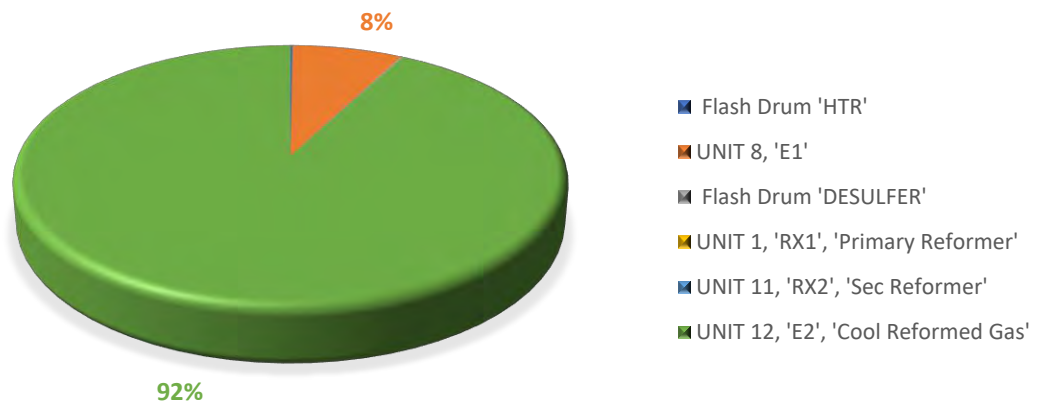
Stage	Energy Consumption (MMKJ/HR)
Stage-1 Catalytic Reforming	1137.647
Stage-2 Shift conversion and gas sweetening	934.57
Stage-3 Compression	344.45
Stage-4 Ammonia Conversion	1168.31
Summary	3584.977

**OVERALL ENERGY CONSUMPTION**

**Figure 4.5** Overall energy consumption of ammonia manufacturing process.

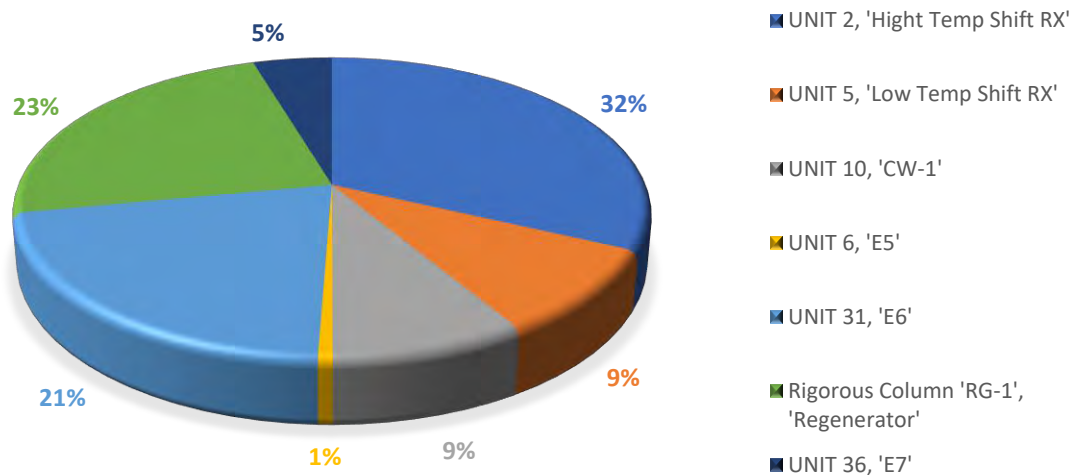
**Table 4.8** Energy consumption of ammonia production in stage 1

Unit	Hot (MMKJ/HR)	Cold (MMKJ/HR)
Flash Drum 'HTR'	1.6881	
UNIT 8, 'E1'	85.496	
Flash Drum 'DESULFER'		1.53926
UNIT 1, 'RX1', 'Primary Reformer'		
UNIT 11, 'RX2', 'Sec Reformer'	9.21E-09	
UNIT 12, 'E2', 'Cool Reformed Gas'		1048.924
Summery	87.1841	1050.463

**ENERGY CONSUMPTION OF AMMONIA PRODUCTION IN STAGE 1****Figure 4.6** Energy consumption of ammonia process in stage 1.

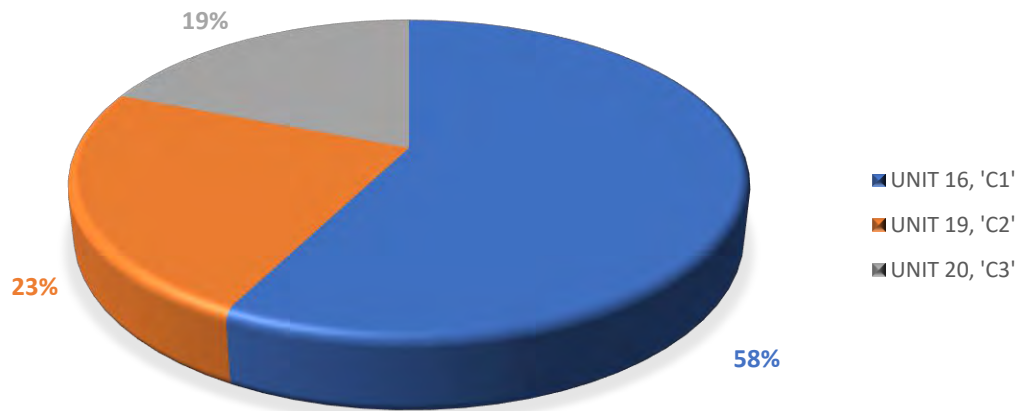
**Table 4.9** Energy consumption of ammonia production in stage 2

Unit	Hot (MMKJ/HR)	Cold (MMKJ/HR)
UNIT 2, 'Hight Temp Shift RX'		369.3353
UNIT 5, 'Low Temp Shift RX'		108.838
UNIT 10, 'CW-1'		100.286
UNIT 6, 'E5'	7.359	
UNIT 31, 'E6'	247.78	
Rigorous Column 'RG-1', 'Regenerator'	165.37	104.47
Pump 'P1'	Shaft work	Shaft work
UNIT 36, 'E7'		541.423
Summery	420.509	1224.352

**ENERGY CONSUMPTION OF AMMONIA PROCESS IN STAGE 2****Figure 4.7** Energy consumption of ammonia process in stage 2.

**Table 4.10** Energy consumption of ammonia production in stage 3

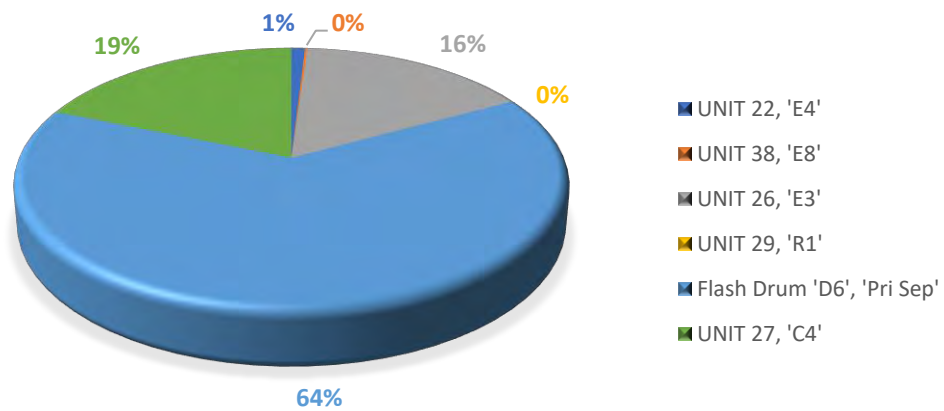
Unit	Cold (MMKJ/HR)	Shaft work (HP)
UNIT 16, 'C1'	198.29	73049.46
UNIT 19, 'C2'	80.57	29426.79
UNIT 20, 'C3'	65.59	24837.57
Summary	344.45	127313.8

**ENERGY CONSUMPTION OF AMMONIA PROCESS IN STAGE 3****Figure 4.8** Energy consumption of ammonia process in stage 3.



**Table 4.11** Energy consumption of ammonia production in stage 4

Unit	Hot (MMKJ/HR)	Cold Refrigerant (MMKJ/HR)
UNIT 22, 'E4'	13.31	
UNIT 38, 'E8'		2.416
UNIT 26, 'E3'	229.601	
UNIT 29, 'RX3'	4.35E-03	
Flash Drum 'D6', 'Pri Sep'		922.9744
UNIT 27, 'C4'	Shaft work	Shaft work
Summery	242.9154	925.3904

**ENERGY CONSUMPTION OF AMMONIA PROCESS IN STAGE 4****Figure 4.9** Energy consumption of ammonia process in stage 4.

#### 4.4 Properties and Specification for Simulation Processes – Urea Plant

For case 2 – Urea manufacturing process, the urea production of the conceptual process is 3,870 ton per day. The carbon dioxide that be eliminated from gas sweetening process is 5,202 ton per day and will be consumed in this process about 5,046 ton per day. The properties and specification of ammonia and carbon dioxide feedstock are shown in the table 1 and 2. The urea product specifications are shown in the table 5. The input data of the conceptual urea manufacturing are shown in the table 6.

**Table 4.12** Ammonia feed for urea manufacturing process

Ammonia feed stock specification	
Ammonia purity (% mole)	99.90%
Flow rate (ton/day)	3,870
Temperature (°C)	-33.33
Pressure (psia)	320

**Table 4.13** Carbon dioxide feed for urea manufacturing process

Carbon dioxide feed stock specification	
Carbon dioxide purity (% mole)	100%
Flow rate (ton/day)	5,046
Temperature (°C)	37.78
Pressure (psia)	300

Table 4.14 Urea product specification

Urea product specification	
Urea purity (% mole)	99.90%
Flow rate (ton/day)	5,472
Temperature (°C)	93.33
Pressure (psia)	-

Table 4.15 Input data of urea process

Reaction Name			Urea synthesis 1
Reaction type			Conversion
Reaction			$8\text{NH}_3 + 4\text{CO}_2 \rightleftharpoons 3\text{CH}_4\text{N}_2\text{O}_2 + 3\text{H}_2\text{O} + \text{NH}_2\text{COONH}_4$
Basis Reactor No. RX4	Base component	Carbon dioxide	
Temperature = 180 °C	Reaction phases	Vapor phase	
Pressure = 15 psia			
Reaction Name			High pressure decomposer
Reaction type			Conversion
Reaction			$\text{NH}_2\text{COONH}_4 \rightleftharpoons 2\text{NH}_3 + \text{CO}_2$
Basis Reactor No. RX5	Base component	Ammonium Carbamate	
Temperature = 180 °C	Reaction phases	Vapor phase	
Pressure = 600 psia			
Reaction Name			Low pressure decomposer
Reaction type			Conversion
Reaction			$\text{NH}_2\text{COONH}_4 \rightleftharpoons 2\text{NH}_3 + \text{CO}_2$
Basis Reactor No. RX6	Base component	Ammonium Carbamate	
Temperature = 120 °C	Reaction phases	Vapor phase	
Pressure = 300 psia			

#### 4.5 Process Flow Diagram – Case 2 Urea Manufacturing Process

Ammonia, temperature  $-33^{\circ}\text{C}$  pressure 320 psia and flow rate of 3,870 ton per day, was fed into the process simulation to mix with Carbon dioxide, temperature  $37^{\circ}\text{C}$  pressure 300 psia and flow rate of 5,046 ton per day. The urea manufacturing process from the software has 5,472 ton per day productivity of urea. The product specifications are temperature  $93^{\circ}\text{C}$ , Solid state and purity of 99.90%. This simulation had been developed by Commercial software Pro II program version 10.0 which was used in urea manufacturing process. NRTL01 thermodynamic model was used to achieve the urea specification product more accurately.

The urea plants are capable of processing 5,472 ton per day. There have 3 main reactors in the process simulation: Urea synthesis reactor, high-pressure decomposer, and low-pressure decomposer. This process is to convert carbon dioxide and synthetic ammonia with high pressure reacted to form into urea which is shown in Figure 4.10.

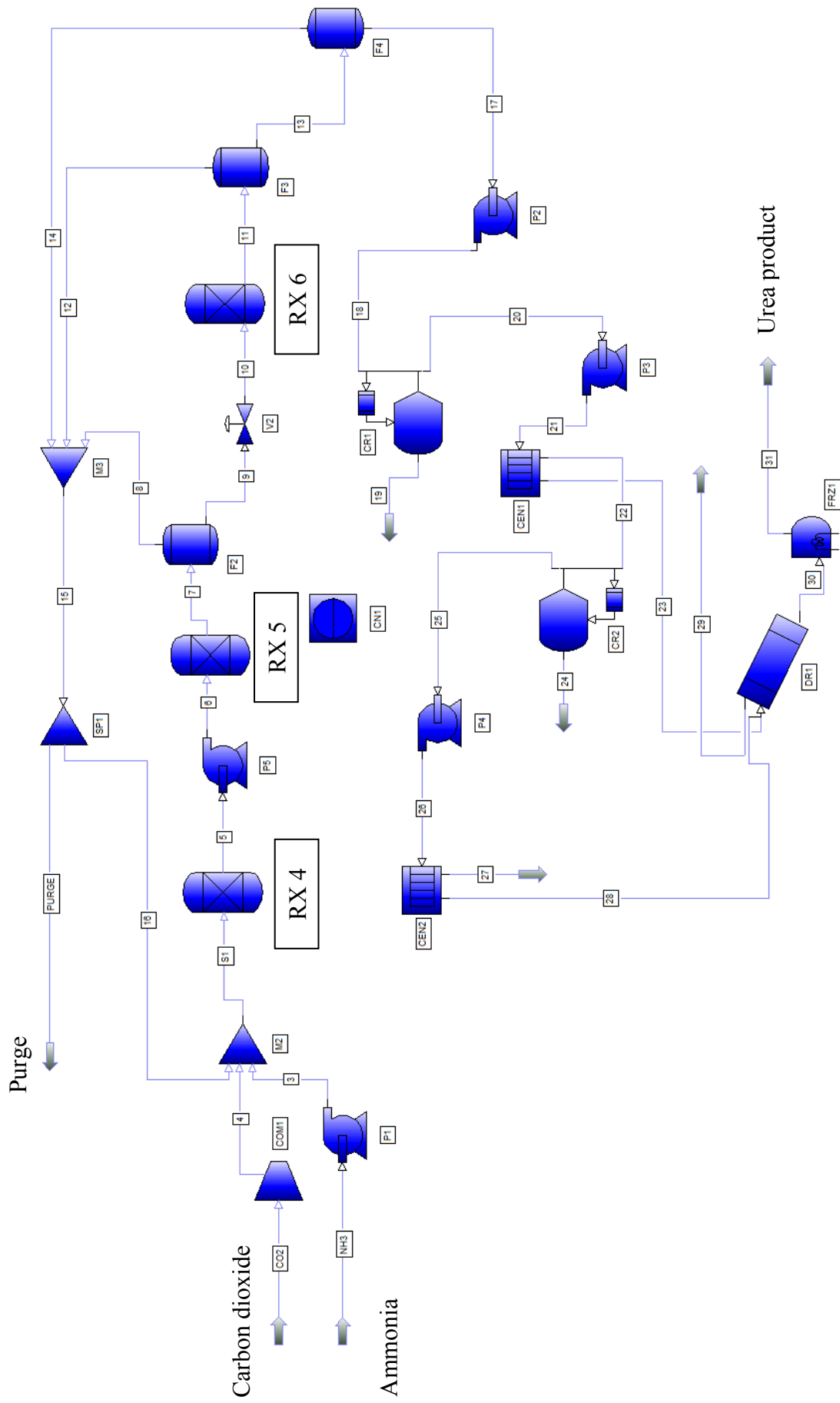


Figure 4.10 The simulation of urea production.

#### 4.6 Energy Consumption Analysis – Urea Manufacturing Process

The Urea synthesis process consists of 21 units. The hot utilities consume energy about  $4.28 \times 10^8$  kJ/hr. The cold utilities consume energy about  $4.93 \times 10^8$  kJ/hr. The shaft work is about  $8.49 \times 10^4$  kW.

**Table 4.16** Energy consumption of urea production

Unit	Hot (MMKJ/HR)	Cold (MMKJ/HR)	Shaft work (HP)
UNIT 1, 'COM1'		113.07	4,2120.6
Pump 'P1'			2,238.42
UNIT 3, 'RX4'		295.3946	
Pump 'P5'			8,3334.51
UNIT 6, 'RX4', 'HP_Decomposer'	288.4287		
UNIT 8, 'RX5', 'LP_Decomposer'		41.1598	
Pump 'P2', 'PUMP2'			4.11
Crystalizer 'CR1', 'CSTAGE1'	55.9019		
Pump 'P3', 'PUMP3'			3.2
Crystalizer 'CR2', 'CSTAGE2'	18.2524		
Pump 'P4', 'PUMP4'			1.29
Solids Dryer 'DR1', 'DRYER'	65.16		
UNIT 19, 'FRZ1', 'FREEZER'		43.3824	
Summery	427.743	493.0068	127702

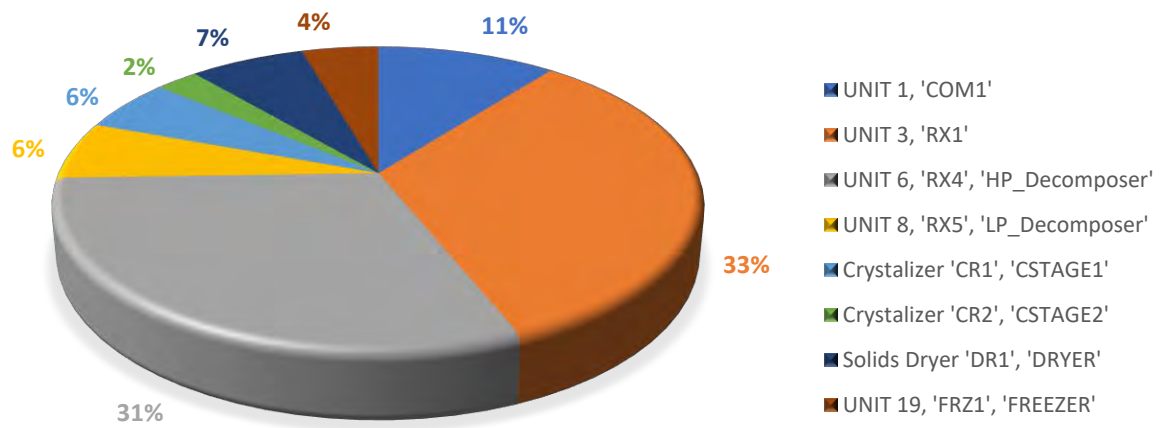
**ENERGY CONSUMPTION OF UREA MANUFACTURING PROCESS**

Figure 4.11 Energy consumption of urea process.

## 4.7 Techno Economic Analysis of the Manufacturing Process

Techno Economic Analysis is to estimate cost of investment and the profitability of project. This cost assessment technique represents the capital expenditure, the operating expenditure, net present value, pay-back period, and return of investment. There are 3 main parts to estimate total investment cost of the project which are

### 4.7.1 Fixed Capital Cost

This cost includes mainly purchasing process equipment. This cost associates with constructing the plant and includes the raw material costs.

#### 4.7.1.1 *Direct Manufacturing Expenditure*

Manufacturing fixed capital investment consisted of site preparation, piping, instrument, process equipment, raw material cost, auxiliary facilities, admin office, warehouses, lab, transportation, shipping, utilities, waste disposal facilities.

#### 4.7.1.2 *Indirect Manufacturing Expenditure*

Expenses which are not directly involved with material and labour e.g. engineering, supervision, legal expenses, maintenance and repair, local taxes, and insurance.

### 4.7.2 Working Capital Investment

This cost includes mainly raw materials and supplies, finished product in stock, operating expenses, and taxes. It can be calculated by 15% of fixed capital cost.

### 4.7.3 Depreciable Investment

Generally, this cost includes all property (Physical facilities, including design and engineering, shipping, and field erection except land) with a limited useful life of more than 1 year. It can be calculated by 10% of fixed capital cost.



Typical process utilities including process steam, electricity, refrigerants, compression air, cooling water, hot oil, process water. For preliminary cost estimation can be treated like utility expense. The two-factor utility cost equation are needed such as the following: and the utilities cost coefficients are represented in table 4.17

$$C_{s,u} = a (CEPCI) + b (C_{s,f}) \quad (6.1)$$

Where  $C_{s,u}$  is the price of the utility,  $a$  and  $b$  are utility cost coefficients  $C_{s,f}$  is the price of fuel in \$/GJ, and CEPCI is an inflation parameter for projects in the U.S.\*

\* Evaluated monthly by the staff of Chemical Engineering

**Table 4.17** Utility cost coefficient with 470 of CEPCI and 7.2 of  $C_{s,f}$

Utility type	Cost coefficient	
	a	b
Onsite power charged to grass-roots plant	$1.1 \times 10^{-4}$	0.010
Hot water for process steam (Qh is total heat capacity in kJ/s, T is absolute temperature)	$6.0 \times 10^{-7} Qh^{-0.9} (T)^{0.5}$	$6.0 \times 10^{-8} T^{0.5}$
Cooling Water (q is water capacity in m <sup>3</sup> /s)	$0.00007 + 2.5 \times 10^{-5} q^{-1}$	0.003
Refrigerant (Qc is total cooling capacity in kJ/s, T is absolute temperature)	$0.5 Qc^{-0.9} (T^{-3})$	$1.1 \times 10^6 T^{-5}$

#### 4.7.4 Expenditure Assessment for Ammonia and Urea Processes

The ammonia manufacturing process or detail on total expenditure are consist of 3 main of utilities cost: 1. Hot water for heat transfer media in the process, 2. Cooling water for cooling temperature of each equipment, and 3. Refrigerant for liquefy ammonia in the process. The details are represented in Table 4.18

**Table 4.18** Expenditure assessment for ammonia manufacturing process

Unit	Energy Consumption type				Cost (\$/year)
	Hot (MM kJ/hr)	Cool (MM kJ/hr)	Shaft work (HP)	Refrigerant (MM kJ/hr)	
Stage-1 Catalytic Reforming					
Flash Drum 'HTR'	1.6881	-	-	-	157,105
UNIT 8, 'E1'	85.496	-	-	-	7,956,763
Flash Drum 'DESULFER'	-	1.53926	-	-	7,043
UNIT 11, 'RX2', 'Sec Reformer'	9.21E-09	-	-	-	8.57E-04
UNIT 12, 'E2', 'Cool Reformed Gas'	-	1048.924	-	-	4,799,657
Stage-2 Shift Conversion					
UNIT 2, 'Hight Temp Shift RX'	-	369.3353	-	-	1,690,001
UNIT 5, 'Low Temp Shift RX'	-	108.838	-	-	498,020
UNIT 10, 'CW-1'	-	100.286	-	-	458,888
UNIT 6, 'E5'	7.359	-	-	-	684,872
UNIT 31, 'E6'	24.78	-	-	-	2,330,446
Rigorous Column 'RG-1',	165.37	104.47	-	-	16,031,241
Pump 'PI'			37.722	-	30,481
UNIT 36, 'E7'	-	54.142	-	-	247,744

**Table 4.18** Expenditure assessment for Ammonia manufacturing process (Continue)

Unit	Energy Consumption type				Cost (\$/year)
	Hot (MM kJ/hr)	Cool (MM kJ/hr)	Shaft work (HP)	Refrigerant (MM kJ/hr)	
<b>Stage-3 Compression</b>					
UNIT 16, 'C1'	-	198.29	73049.46	-	59,027,567
UNIT 19, 'C2'	-	80.57	29426.79	-	23,778,298
UNIT 20, 'C3'	-	65.59	24837.57	-	20,069,982
<b>Stage-4 Ammonia Conversion</b>					
UNIT 22, 'E4'	13.31	-	-	-	1,238,707
UNIT 38, 'E8'	-	-	-	2.416	186,064
UNIT 26, 'E3'	229.601	-	-	-	21,368,025
UNIT 29, 'R1'	4.35E-03	-	-	-	405
Flash Drum 'D6', 'Pri Sep'	-	-	-	922.9744	71,081,132
UNIT 27, 'C4'	-	-	269.4	-	217,688
Summarizes					231,860,129

**Table 4.19** Expenditure assessment for urea manufacturing process from 3,870 TPD ammonia feed

Unit	Energy Consumption type				Cost (\$/year)
	Hot (MM kJ/hr)	Cool (MM kJ/hr)	Shaft work (HP)	Refrigerant (MM kJ/hr)	
Urea conversion					
UNIT 1, 'COM1'	-	113.07	42120.6	-	34,552,907
Pump 'P1'	-	-	2283.42	-	1,845,116
UNIT 3, 'RX1'	-	295.3946	-	-	1,351,664
Pump 'P5'	-	-	83334.51	-	67,338,395
UNIT 6, 'RX4', 'HP_Decomposer'	288.4287	-	-	-	26,842,879
UNIT 8, 'RX3', 'LP_Decomposer'	-	41.1598	-	-	188,339
Pump 'P2', 'PUMP2'	-	-	4.11	-	3,321
Crystallizer 'CR1', 'CSTAGE1'	65.4908	-	-	-	6,094,961
Pump 'P3', 'PUMP3'	-	-	3.2	-	2,586
Crystallizer 'CR2', 'CSTAGE2'	18.2524	-	-	-	1,698,676
Pump 'P4', 'PUMP4'	-	-	1.29	-	1,042
Solids Dryer 'DRI', 'DRYER'	65.16	-	-	-	6,064,174
UNIT 19, 'FRZ1', 'FREEZER'	-	43.3824	-	-	198,509
Summarizes					146,182,569

## EXPENDITURE OF AMMONIA PROCESS UTILITIES (\$/YEAR)

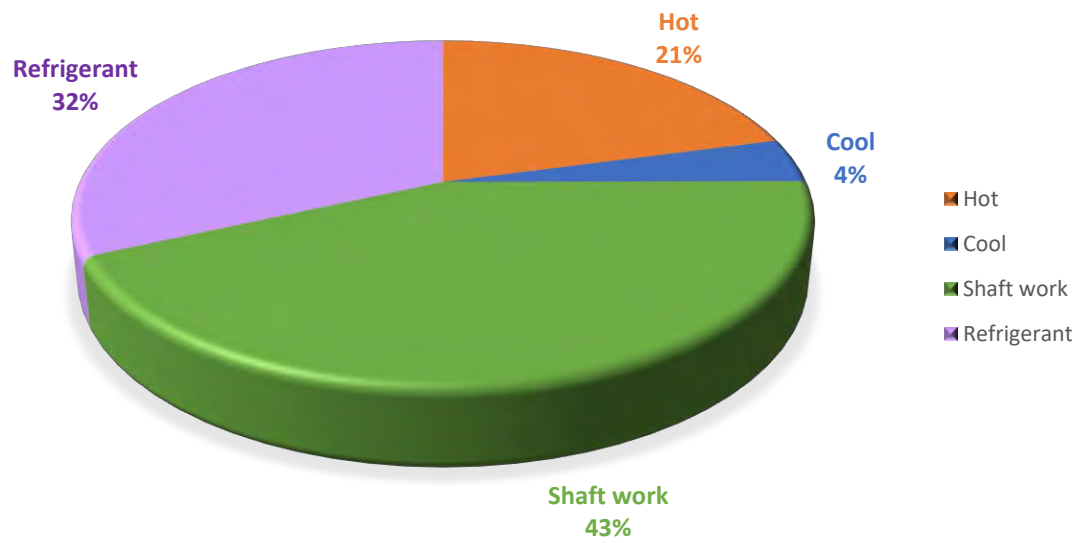


Figure 4.12 Expenditure of ammonia process divided by utility type.

## EXPENDITURE OF UREA PROCESS UTILITIES (\$/YEAR)

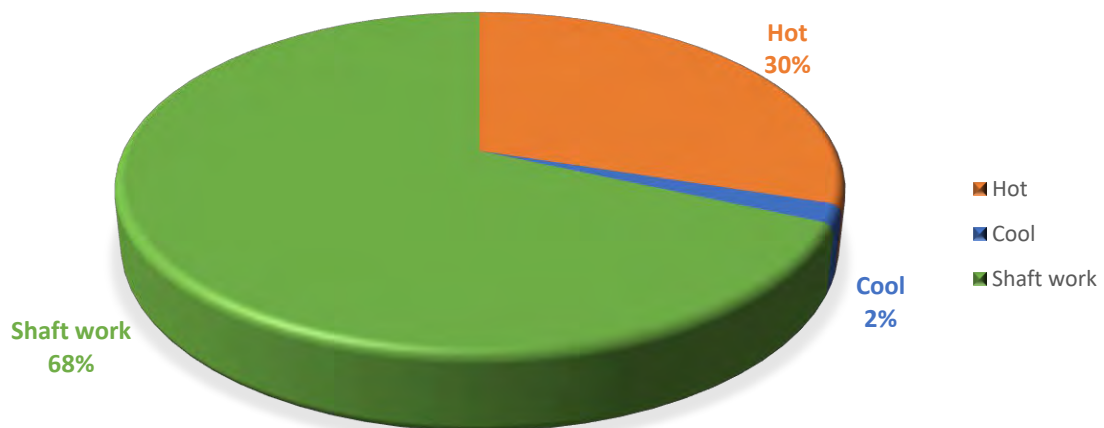


Figure 4.13 Expenditure of urea process divided by utility type.



2619937106

CD IThesis 6173002063 thesis / rev: 20072563 10:48:08 / seq: 18

**Table 4.20** Detail Purchased Equipment Cost

Unit	Purchased Cost (\$)
Reactors (10)	15,991,253
Flash drum (11)	1,432,874
Distillation column (2)	38,854
Centrifugal Pump (6)	79,536
Centrifugal Compressor (5)	6,180,612
Fired Heated	19,013,389.14
Summarizes	42,736,518.3

**Table 4.21** Detail total expenditure for ammonia and urea manufacturing

Components	%	Cost (\$)
Direct cost		
Purchased equipment installation	47	20,086,164
Instrumentation (installed)	12	5,128,382
Piping (installed)	66	28,206,102
Electrical (installed)	11	4,701,017
Building (including Service)	18	7,692,573
Yard improvement	10	4,273,652
Service facilities	70	29,915,563
Land	6	2,564,191
Total direct cost		145,304,162
Indirect cost		
Engineering and supervision	33	14,103,051
Construction Expenses	41	17,521,973
Total Indirect Cost		31,625,024
Total Direct & Indirect Cost		176,929,186
Contractor's fee	5	8,846,459
Contingency	10	17,692,919
Fixed Capital Investment		203,468,564
Working Capital investment	15	30,520,285
Total Capital Investment (CAPEX)		233,988,848

**Table 4.22** Key assumptions used to develop the techno-economic model

Base year	2019
Plant lifetime	10 years
Operating hour per year (h)	8760
Annual Ammonia Capacity (ton)	1,412,550
Ammonia price (\$/ton)	206
Annual Urea Capacity (ton)	1,997,280
Urea price (\$/ton)	288
CAPEX (\$)	233,988,848
Interest rate (%)	10
Payback period (y)	5.4
Net present value (\$)	197,175,232



2619937106

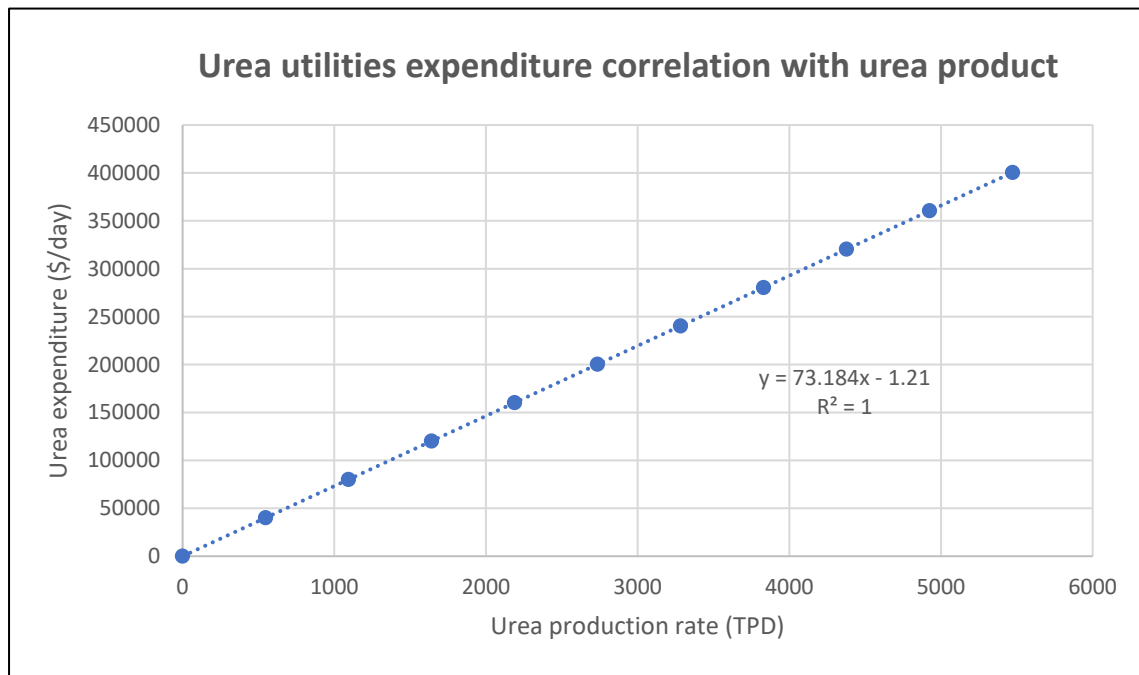
CU Theses 6173002063 thesis / recv: 20072563 10:48:08 / seq: 18

Ammonia product from the case-1 can be as the substrate for the urea process by mixing with carbon dioxide and react at high temperature. The expenditure of urea process be varied with the energy consumption that be changed with the amount of feedstock. For being economical, correlation between ammonia and urea manufacturing process will be considered. The maximum capacity of ammonia manufacturing is 3,870 TPD which feed for substrate in urea process. It can be distributed into 11 operating scenarios by 10 % reducing amount of ammonia feed to urea process as shown in table 4.23.

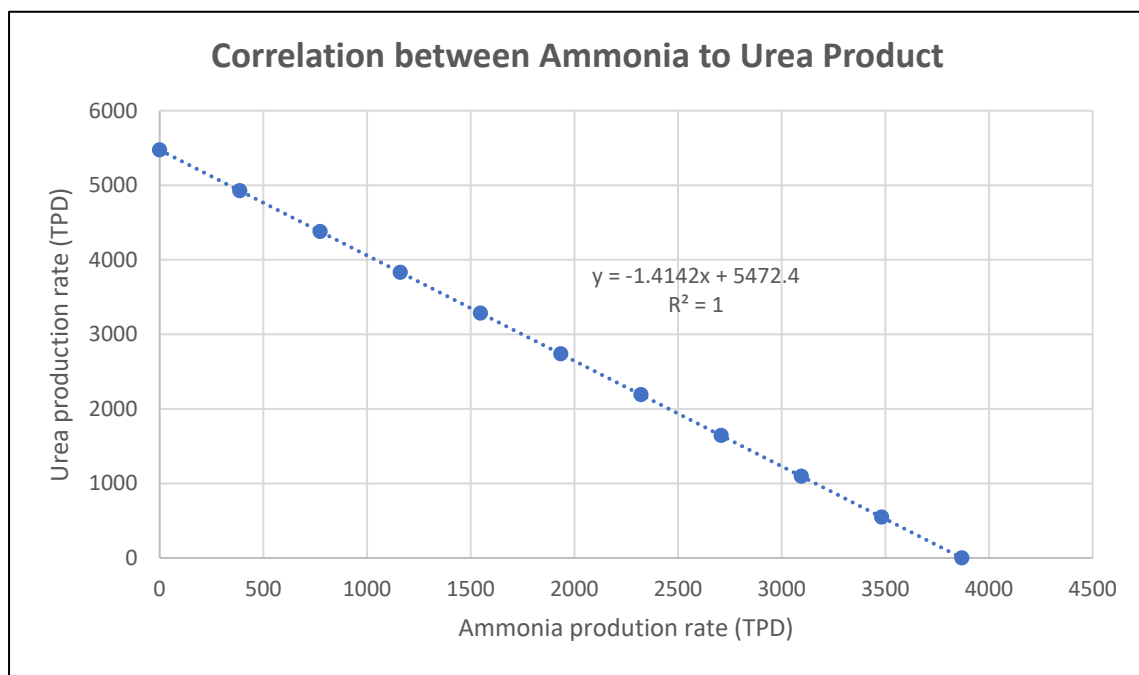
**Table 4.23** Correlation between ammonia feed to urea product

Scenario No.	Ammonia Feed to urea process (Ton/day)	Urea Production (Ton/day)	Ammonia Production (Ton/day)	Urea Expenditure (\$/day)
1	3,870	5,472	0	400,500
2	3,483	4,925	387	360,435
3	3,096	4,378	774	320,390
4	2,707	3,831	1,161	280,339
5	2,322	3,283	1,548	240,293
6	1,935	2,736	1,935	200,243
7	1,548	2,189	2,322	160,193
8	1,161	1,642	2,707	120,145
9	774	1,094	3,096	80,097
10	387	547	3,483	40,048
11	0	0	3,870	0





**Figure 4.15** Urea utilities expenditure correlation with urea product.



**Figure 4.14** Correlation between ammonia to urea product.

#### 4.8 Investigation on Optimization of Market Demand (with Fixed Production Capacity of Ammonia and Urea)

The supply chain can be defined as the flow of materials or information from basic commodities or raw materials to final products for end-customer through many processes that are linked together to chain. In this first case study, the network has with 2 echelons; Plant (i) with 2 products (ammonia and urea), and Market (j) with 2 products (ammonia and urea). The mathematical model for designing the network is expressed as show below.

$$\text{Max } Z = \text{Price}_{\text{Amm}} * \sum_i \sum_j X_{ij} + \text{Price}_{\text{Urea}} \sum_i \sum_j Y_{ij} - [\text{Cost1} + \text{Cost2} + \text{Cost3}] \quad (6.1)$$

Subject to constraints,

$$\sum_j X_{ij} = \text{LimCapAmm}_i \quad (6.2)$$

$$\sum_j Y_{ij} = \text{LimCapUrea}_i \quad (6.3)$$

$$\sum_i X_{ij} + \sum_i \text{PenaltyAmm}_{ij} - \text{PPAmm}_j = \text{LimAmm}_j \text{ (Demand)} \quad (6.4)$$

$$\sum_i Y_{ij} + \sum_i \text{PenaltyUrea}_{ij} - \text{PPUrea}_j = \text{LimUrea}_j \text{ (Demand)} \quad (6.5)$$

$$\text{Cost1} = 795470 \quad (6.6)$$

$$\text{Cost2} = (\sum_i \sum_j X_{ij} + \sum_i \sum_j Y_{ij}) * \text{transportcost} \quad (6.7)$$

$$\begin{aligned} \text{Cost3} = & \sum_i \sum_j \text{PenaltyAmm}_{ij} * \text{PAmmCost} + \sum_i \sum_j \text{PPAmm}_j * \text{PPAmmCost} + \\ & \sum_i \sum_j \text{PenaltyUrea}_{ij} * \text{PUreaCost} + \sum_i \sum_j \text{PPUrea}_j * \text{PPUreaCost} \end{aligned} \quad (6.8)$$

Where

$X_{ij}$  = Ammonia transportation amount (TPD)

$Y_{ij}$  = Urea transportation amount (TPD)

$\text{LimCapAmm}_i$  = Ammonia production capacity of plant i in cases (TPD)

$\text{LimCapUrea}_i$  = Urea production capacity of plant i in cases (TPD)

$\text{PenaltyAmm}_{ij}$  = Ammonia amount which less than demand of market (TPD)

$\text{PenaltyUrea}_{ij}$  = Urea amount which less than demand of market (TPD)

$\text{PPAmm}_j$  = Ammonia amount which greater than demand of market (TPD)

$\text{PPUrea}_j$  = Urea amount which greater than demand of market (TPD)

$\text{LimAmm}_j (\text{Demand}) = \text{Ammonia demand of market } j \text{ in cases (TPD)}$

$\text{LimUrea}_j (\text{Demand}) = \text{Urea demand of market } j \text{ in cases (TPD)}$

$\text{Opportunity loss cost} = \sum_i \sum_j \text{PenaltyAmm}_{ij} * \text{PAmmCost} (\$/\text{day})$

$\text{Surplus Production cost} = \sum_i \sum_j \text{PPAmm}_j * \text{PPAmmCost} (\$/\text{day})$

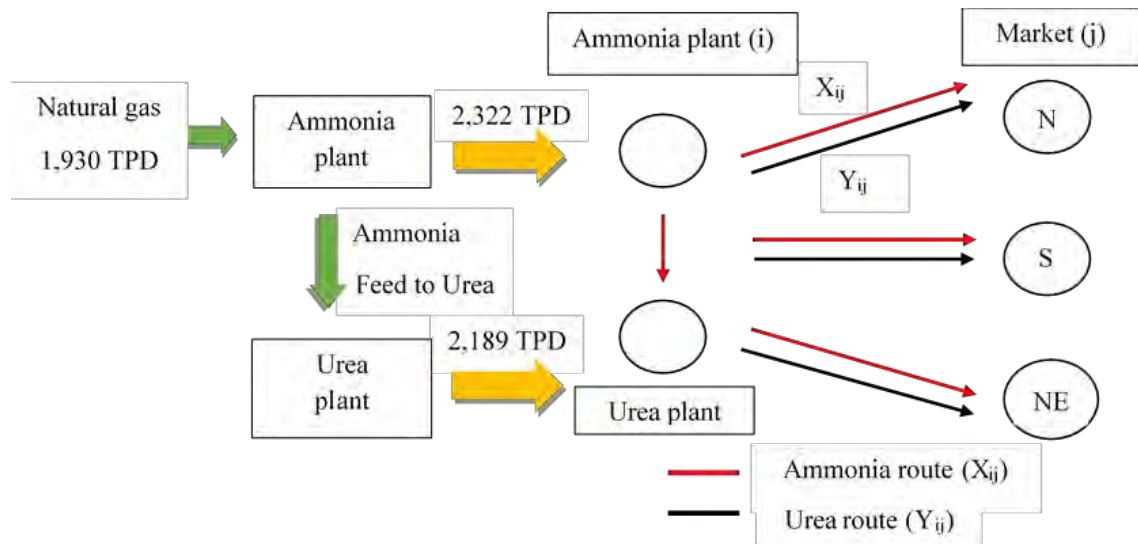
$\text{Cost1} = \text{Ammonia and urea production cost at urea production rate 2,322 TPD}$   
 $(\$/\text{day})$

$\text{Cost2} = \text{transportation cost} (\$/\text{day})$

$\text{Cost3} = \text{Penalty cost} (\$/\text{day})$

The main objective of this model is to maximize profit from sale products. The objective function is expressed into 3 parts; revenue, transportation cost, and penalty cost as shown in equation 6.1. The penalty cost is opportunity loss that the products are lower than demand of the market and cannot be sold. Equation 6.2 and 6.3 are deal with maximum capacity of plant in ammonia product and urea product, respectively. Equation 6.4 and 6.5 are deal with minimum demand of the market in ammonia product and urea product, respectively. The market's demand data was assumed as a historical for optimized programming by using normal distribution of mean and standard derivation as shown in figure 4.18.

The case study for deterministic and stochastic models use historical demand data of 30 days. The simple supply chain network with 2 echelons; Plant (i) and Market (j) with 2 products (ammonia and urea) is shown in figure 4.16.

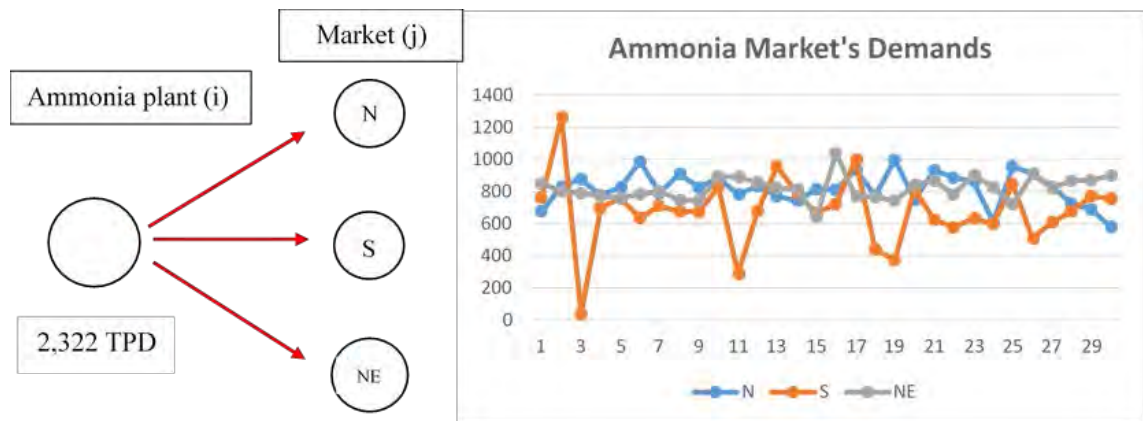


**Figure 4.16** The simple supply chain network diagram.

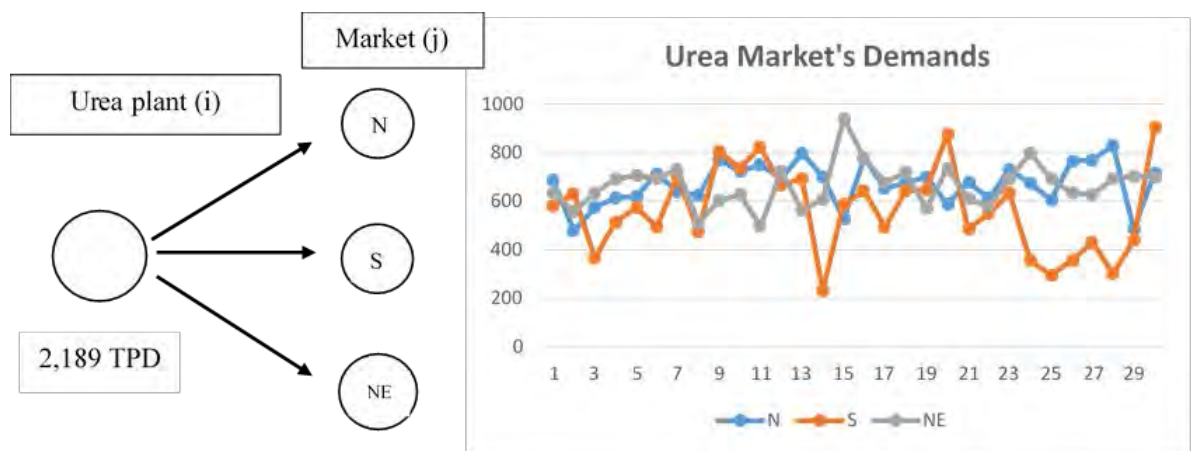
**Table 4.24** The data related to the network

Market	Distance (miles)
N	531
S	684
NE	208
Product sale price*	(\$/ton)
Ammonia	206 (Yuzhny)
Urea	288 (granular Indonesia/Malaysia)
Transportation cost (\$/ton/miles)	0.05
Opportunity loss (\$/unit)	50% of product selling price
Surplus Production Cost (\$/unit)	25% of product selling price

\*Source; AfricaFertilizer.org FOB International Fertilizer Prices – updated at December 2019 (price data from Jul-19)



	N	S	NE
Mean	800	700	800
SD	100	300	100



	N	S	NE
Mean	650	500	650
SD	100	200	100

Ammonia and urea capacity are from correlation function:  $y = -1.4142x + 5472.4$

**Figure 4. 17** Ammonia and urea demands of each market.

**Table 4.25** The result of supply chains model network – fixed production capacity of ammonia and urea

Supply chain No.X using product demand of	Market (j) (TPD)			Penalty cost (\$)	Transportation cost (\$)	Profit Z cost (\$)
	N (j1)	S (j2)	NE (j3)			
No.1 using demand of day 1				22,312	100,906	190,076
Ammonia Demand	677	762	851			
Ammonia shipping amount (x)	677	762	801	1,648	53,218	
Urea Demand	687	581	634			
Urea shipping amount (y)	687	581	921	20,664	47,688	
No.2 using demand of day 2				96,737	99,495	117,062
Ammonia Demand	834	1,262	801			
Ammonia shipping amount (x)	834	687	801	59,225	53,969	
Urea Demand	478	632	558			
Urea shipping amount (y)	478	632	1,079	37,512	45,527	
No.3 using demand of day 3				75,932	79,996	157,366
Ammonia Demand	878	38	790			
Ammonia shipping amount (x)	878	38	1,406	31,724	39,233	
Urea Demand	575	366	634			
Urea shipping amount (y)	575	366	1,248	44,208	40,763	
No.4 using demand of day 4				30,348	98,248	184,698
Ammonia Demand	777	700	773			
Ammonia shipping amount (x)	777	700	845	3,708	53,357	
Urea Demand	614	513	692			
Urea shipping amount (y)	614	513	1,062	26,640	44,891	
No.5 using demand of day 5				23,033	101,494	188,767
Ammonia Demand	828	758	759			
Ammonia shipping amount (x)	828	735	759	2,369	55,014	
Urea Demand	621	575	706			
Urea shipping amount (y)	621	575	993	20,664	46,480	

**Table 4.25** The result of supply chains model network – fixed production capacity of ammonia and urea (Continue)

Supply chain No.X using product demand of	Market (j) (TPD)			Penalty cost (\$)	Transportation cost (\$)	Profit Z (\$)
	N (j1)	S (j2)	NE (j3)			
No.6 using demand of day 6				29,594	99,224	184,476
Ammonia Demand	987	637	784			
Ammonia shipping amount (x)	987	551	784	8,858	53,203	
Urea Demand	712	494	695			
Urea shipping amount (y)	712	494	983	20,736	46,022	
No.7 using demand of day 7				9,382	103,638	200,274
Ammonia Demand	790	711	801			
Ammonia shipping amount (x)	790	711	821	1,030	53,829	
Urea Demand	640	702	731			
Urea shipping amount (y)	640	702	847	8,352	49,809	
No.8 using demand of day 8				42,996	98,773	171,525
Ammonia Demand	911	675	748			
Ammonia shipping amount (x)	911	663	748	1,236	54,641	
Urea Demand	623	475	511			
Urea shipping amount (y)	623	475	1,091	41,760	44,132	
No.9 using demand of day 9				4,768	107,890	200,636
Ammonia Demand	825	674	743			
Ammonia shipping amount (x)	825	674	823	4,120	53,514	
Urea Demand	771	805	604			
Urea shipping amount (y)	771	805	613	648	54,376	
No.10 using demand of day 10				37,142	103,301	172,851
Ammonia Demand	888	829	895			
Ammonia shipping amount (x)	888	539	895	29,870	51,318	
Urea Demand	723	737	628			
Urea shipping amount (y)	723	737	729	7,272	51,983	

**Table 4.25** The result of supply chains model network – fixed production capacity of ammonia and urea (Continue)

Supply chain No.X using product demand of	Market (j) (TPD)			Penalty cost (\$)	Transportation cost (\$)	Profit Z (\$)
	N (j1)	S (j2)	NE (j3)			
No.11 using demand of day 11				27,160	98,098	188,037
Ammonia Demand	782	288	891			
Ammonia shipping amount (x)	782	288	1,252	18,592	43,633	
Urea Demand	750	823	497			
Urea shipping amount (y)	750	823	616	8,568	54,466	
No.12 using demand of day 12				12,741	102,469	198,084
Ammonia Demand	836	680	857			
Ammonia shipping amount (x)	836	680	857	5,253	52,620	
Urea Demand	694	667	724			
Urea shipping amount (y)	694	667	828	7,488	49,848	
No.13 using demand of day 13				32,926	106,105	174,263
Ammonia Demand	770	956	822			
Ammonia shipping amount (x)	770	730	822	23,278	53,958	
Urea Demand	798	693	564			
Urea shipping amount (y)	798	693	698	9,648	52,147	
No.14 using demand of day 14				49,612	93,916	169,766
Ammonia Demand	743	791	816			
Ammonia shipping amount (x)	743	763	816	2,884	54,308	
Urea Demand	701	232	607			
Urea shipping amount (y)	701	232	1,256	46,728	39,608	
No.15 using demand of day 15				19,773	98,473	195,048
Ammonia Demand	815	667	642			
Ammonia shipping amount (x)	815	667	840	10,197	53,186	
Urea Demand	528	588	940			
Urea shipping amount (y)	528	588	1,073	9,576	45,287	



**Table 4.25** The result of supply chains model network – fixed production capacity of ammonia and urea (Continue)

Supply chain No.X using product demand of	Market (j) (TPD)			Penalty cost (\$)	Transportation cost (\$)	Profit Z (\$)
	N (j1)	S (j2)	NE (j3)			
No.16 using demand of day 16				27,396	98,860	187,038
Ammonia Demand	812	722	1,040			
Ammonia shipping amount (x)	812	470	1,040	25,956	48,449	
Urea Demand	779	643	777			
Urea shipping amount (y)	779	633	777	1,440	50,412	
No.17 using demand of day 17				65,729	98,955	148,610
Ammonia Demand	935	999	771			
Ammonia shipping amount (x)	935	616	771	39,449	53,910	
Urea Demand	653	493	678			
Urea shipping amount (y)	653	493	1,043	26,280	45,045	
No.18 using demand of day 18				28,362	96,140	188,793
Ammonia Demand	776	439	766			
Ammonia shipping amount (x)	776	439	1,107	17,562	47,129	
Urea Demand	676	644	719			
Urea shipping amount (y)	676	644	869	10,800	49,010	
No.19 using demand of day 19				30,101	98,685	184,509
Ammonia Demand	997	375	743			
Ammonia shipping amount (x)	997	375	950	10,661	49,175	
Urea Demand	701	648	570			
Urea shipping amount (y)	701	648	840	19,440	49,509	
No.20 using demand of day 20				10,442	106,476	196,376
Ammonia Demand	751	815	842			
Ammonia shipping amount (x)	751	729	842	8,858	53,628	
Urea Demand	588	876	736			
Urea shipping amount (y)	588	865	736	1,584	52,849	

**Table 4.25** The result of supply chains model network – fixed production capacity of ammonia and urea (Continue)

Supply chain No.X using product demand of	Market (j) (TPD)			Penalty cost (\$)	Transportation cost (\$)	Profit Z (\$)
	N (j1)	S (j2)	NE (j3)			
No.21 using demand of day 21				40,417	96,922	175,955
Ammonia Demand	932	625	868			
Ammonia shipping amount (x)	932	578	868	10,609	51,624	
Urea Demand	679	486	610			
Urea shipping amount (y)	679	486	1,024	29,808	45,298	
No.22 using demand of day 22				36,211	97,938	179,145
Ammonia Demand	887	578	783			
Ammonia shipping amount (x)	887	578	857	3,811	52,230	
Urea Demand	613	548	578			
Urea shipping amount (y)	613	548	1,028	32,400	45,708	
No.23 using demand of day 23				17,713	100,924	194,657
Ammonia Demand	864	633	904			
Ammonia shipping amount (x)	864	554	904	8,137	51,288	
Urea Demand	731	633	692			
Urea shipping amount (y)	731	633	825	9,576	49,637	
No.24 using demand of day 24				40,474	90,436	182,384
Ammonia Demand	612	599	827			
Ammonia shipping amount (x)	612	599	1,111	14,626	48,289	
Urea Demand	674	357	799			
Urea shipping amount (y)	674	357	1,158	25,848	42,147	
No.25 using demand of day 25				63,378	94,504	155,412
Ammonia Demand	955	844	721			
Ammonia shipping amount (x)	955	646	721	20,394	54,947	
Urea Demand	605	295	692			
Urea shipping amount (y)	605	295	1,289	42,984	39,557	

**Table 4.25** The result of supply chains model network – fixed production capacity of ammonia and urea (Continue)

Supply chain No.X using product demand of	Market (j)			Penalty cost (\$)	Transportation cost (\$)	Profit Z (\$)
	N (j1)	S (j2)	NE (j3)			
No.26 using demand of day 26				32,072	94,403	186,819
Ammonia Demand	913	509	908			
Ammonia shipping amount (x)	913	501	908	824	50,818	
Urea Demand	766	355	634			
Urea shipping amount (y)	766	355	1068	31,248	43,586	
No.27 using demand of day 27				39,609	94,236	179,450
Ammonia Demand	627	610	822			
Ammonia shipping amount (x)	627	610	1,085	13,545	48,793	
Urea Demand	769	431	627			
Urea shipping amount (y)	769	431	989	26,064	45,443	
No.28 using demand of day 28				38,136	95,368	179,791
Ammonia Demand	726	677	686			
Ammonia shipping amount (x)	726	677	919	12,000	51,986	
Urea Demand	830	303	693			
Urea shipping amount (y)	830	303	1,056	26,136	43,382	
No.29 using demand of day 29				41,669	94,427	177,198
Ammonia Demand	690	772	871			
Ammonia shipping amount (x)	690	761	871	1,133	53,404	
Urea Demand	485	438	703			
Urea shipping amount (y)	485	438	1,266	40,536	41,023	
No.30 using demand of day 30				23,386	104,211	185,697
Ammonia Demand	580	756	901			
Ammonia shipping amount (x)	580	756	986	4,378	51,509	
Urea Demand	716	904	701			
Urea shipping amount (y)	716	772	701	19,008	52,703	

**Table 4.25** The result of supply chains model network – fixed production capacity of ammonia and urea (Continue)

Supply chain No.X using product demand of	Market (j)			Penalty cost (\$)	Transportation cost (\$)	Profit Z (\$)
	N (j1)	S (j2)	NE (j3)			
Deterministic using average demand				21,488	100,521	191,286
Ammonia Demand	813	679	814			
Ammonia shipping amount (x)	813	679	830	824	53,439	
Urea Demand	673	565	664			
Urea shipping amount (y)	673	565	951	20,664	47,082	

\* The amounts of transportation are assumed to be sold all of product in day (not accumulate)

From Table 4.25, The optimal ammonia shipping amount ( $x$ ) and urea shipping amount ( $y$ ) are represented for 30 days. There are 30 supply chains both ammonia and urea. The products shipping amount both ammonia and urea ( $x$  and  $y$ ) that are transported greater than demand of the market ( $j$ ) or oversupply product will be sold with cheaper selling price about 25% of product selling price. The products which are transported lower than demand of the market ( $j$ ) or lacked product will have penalty cost about 50% of product selling price. The transportation cost is from the distance between plant and market and amount of product which transported to the market. The distance between plant and markets  $N(j1)$ ,  $S(j2)$ , and  $NE(j3)$  are assumed as 531, 684, 208 miles, respectively. The transportation cost is 0.05 \$/tons/miles as shown in the table 4.24. These conditions are made for programming optimization. In this part, 6.8 Investigation on Optimization of Market Demand (with Fixed Production Capacity of Ammonia and Urea), The capacity of ammonia and urea are fixed with 2,322 and 2,189 TPD, respectively. These productions capacities are from amount of natural gas feed stock of 1,930 TPD and the correlation between ammonia and urea production capacity.

For deterministic optimization method, the average demand of the market in 30 days are considered for optimal ammonia and urea transportation for maximizing profit. The average of ammonia demands in 3 markets  $N(j1)$ ,  $S(j2)$ , and  $NE(j3)$  are 813, 679, and 814 TPD, respectively. The average of urea demands in 3 markets  $N(j1)$ ,  $S(j2)$ , and  $NE(j3)$  are 673, 565, and 664 TPD, respectively. The optimization programming for deterministic method were carried out to determine the appropriate amount of ammonia and urea transported to each market that make the highest profit for 30 days. The average demands are representative for the data set to program assessment. The optimal value of ammonia and urea transportation are used for products transportation further all 30 days. The summation of profit in 30 days for the deterministic method is \$ 4,417,229 as shown in table 4.26. From deterministic method, profit and transported products amount were limited to deterministic values of all economic parameters represents only current average demand of the markets, its do not represent the range of profit. However, stochastic analysis method as a probabilistic approach can provide more accurate and dependable result considering effect of uncertainty demand of market according to randomness in input variable.

For stochastic optimization method, the demands of market in 30 days are considered for optimal the ammonia and urea transportation amount for maximizing profit as the previous part. To deal with uncertainties occurred due to randomness, stochastic optimization method was conducted. The demands of produces each day were considered for programming optimization. In stochastic method, there are 30 supply chains with 30 optimal values of ammonia and urea transporting amount for each day in 30 days. These values of each supply chains are used for products transportation all 30 days and assessment summation profit of each supply chains. The ammonia and urea transportation amount and summation profit of each supply chains are represented in table 4.26. The difference of profit in 30 days of each supply chains are from differential amount of products transportation and the transported products which not satisfy market's demand of each day. From supply chain No.12 and No.13 give the optimal value for all 30 days which higher profit compare with other supply chains.



261937106

CU IThesis 6173002063 thesis / recv: 20072563 10:48:08 / seq: 18

**Table 4.26** The optimal value of ammonia and urea transportation for 30 days (historical)

Supply chain No.	Ammonia (TPD)			Urea (TPD)			$\Sigma$ Profit in 30 days (\$)
	N(j1)	S(j2)	NE(j3)	N(j1)	S(j2)	NE(j3)	
1	677	762	883	687	581	921	4,261,121
2	834	687	801	478	632	1,079	3,612,559
3	878	38	1,406	575	366	1,248	1,272,161
4	777	700	845	614	513	1,062	4,024,657
5	828	735	759	621	575	993	4,163,854
6	987	551	784	712	494	983	3,967,235
7	790	711	821	640	702	847	4,482,196
8	911	663	748	623	475	1,091	3,803,846
9	825	674	823	771	805	613	4,396,103
10	888	539	895	723	737	729	4,491,968
11	782	288	1,252	750	823	616	3,194,335
12	836	629	857	694	667	828	4,619,053
13	770	730	822	798	693	698	4,622,681
14	743	763	816	701	232	1,256	2,920,295
15	815	667	840	528	588	1,073	3,811,853
16	812	470	1,040	779	633	777	4,194,749
17	935	616	771	653	493	1,043	3,961,130
18	776	439	1,107	676	644	869	3,905,657
19	997	375	950	701	648	840	3,924,620
20	751	729	842	588	865	736	4,168,108
21	932	522	868	679	486	1,024	3,939,965
22	887	578	857	613	548	1,028	4,032,835
23	864	554	904	731	633	825	4,497,610
24	612	599	1,111	674	357	1,158	2,901,301
25	955	646	721	605	295	1,289	2,750,758
26	913	501	908	766	355	1,068	3,470,858
27	627	610	1,085	769	431	989	3,476,222
28	726	677	919	830	303	1,056	3,349,787
29	690	761	871	485	438	1,266	2,884,286
30	580	756	986	716	772	701	4,064,320
Deterministic	813	679	830	673	565	951	4,417,229

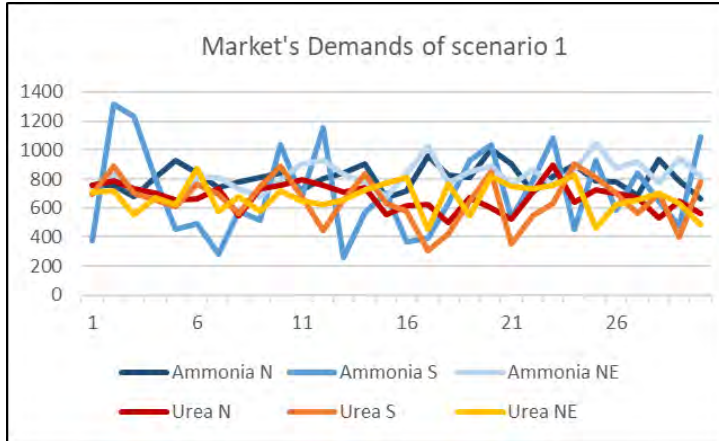
The uncertainty demands of ammonia and urea for 30 days evaluated in previous part are assumed as historical data for the optimal programming. After optimal value of ammonia and urea transported for each market are estimated, the validation part is essential for reach more precise of optimal programming.

The validation part is created from new set of uncertainty demands of ammonia and urea by using the same statistic values of mean and standard deviation as the historical data as shown in figure 4.19. The mean of ammonia demand of 3 markets N(j1), S(j2), and NE(j3) are 800, 700, and 800 TPD and the standard deviation are 100, 300, and 100, respectively. The mean of urea demand of 3 markets N(j1), S(j2), and NE(j3) are 650, 500, and 650 TPD and the standard deviation are 100, 200, and 100, respectively. In validation part, the new set of market's demands are divided into 12 scenarios, 30 days per scenarios (all 360 days of various data).

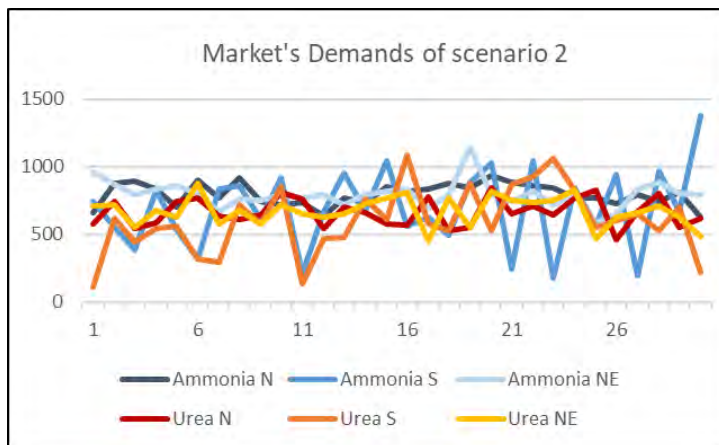


2619937106

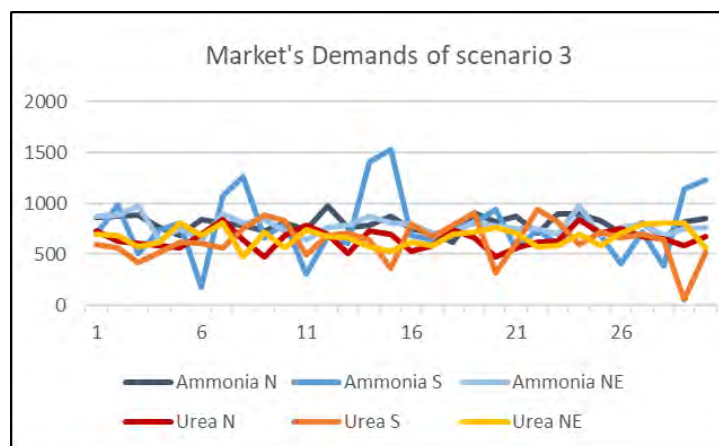




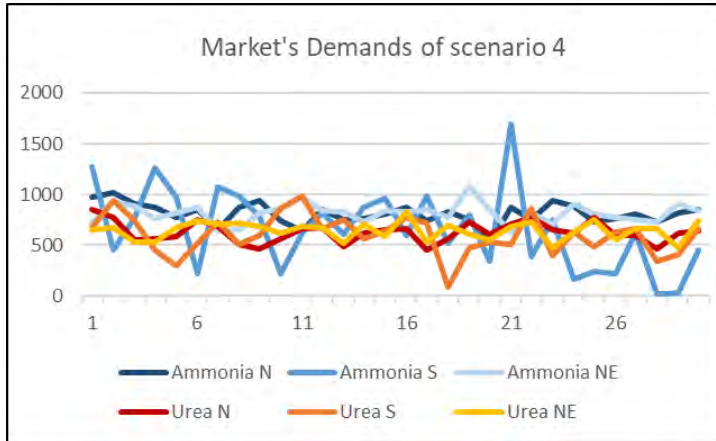
Supply chain	$\Sigma$ Profit in 30 days (\$)
No.12	4,434,405
No.13	4,374,110
Deterministic	4,029,897



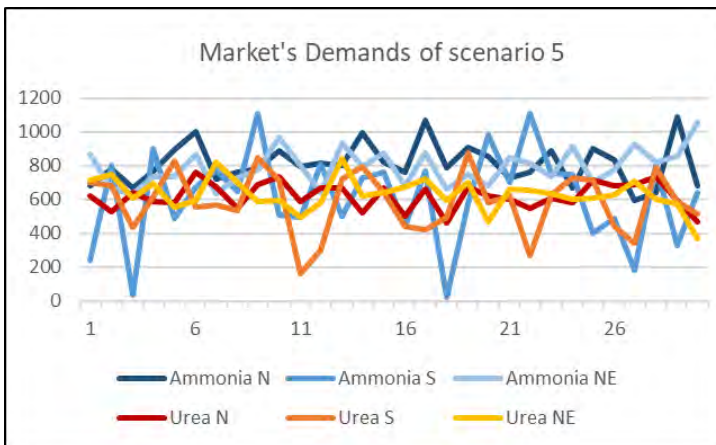
Supply chain	$\Sigma$ Profit in 30 days (\$)
No.12	4,159,928
No.13	4,258,861
Deterministic	3,953,018



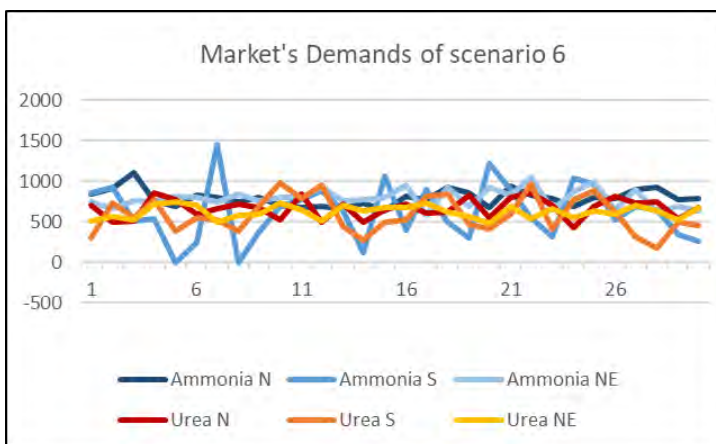
Supply chain	$\Sigma$ Profit in 30 days (\$)
No.12	4,349,241
No.13	4,358,452
Deterministic	4,065,812



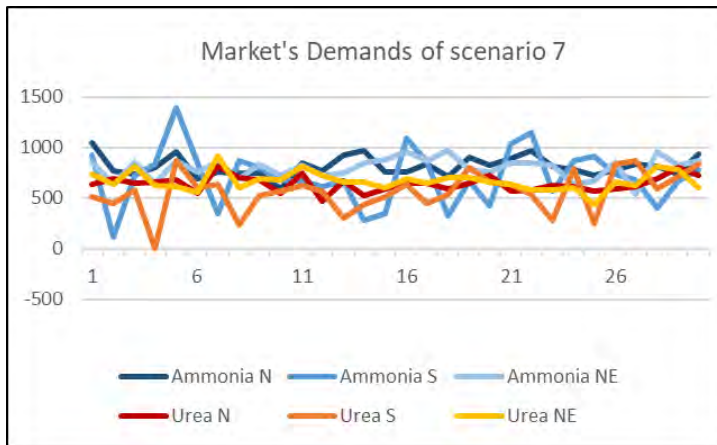
Supply chain	$\Sigma$ Profit in 30 days (\$)
No.12	4,156,064
No.13	4,116,949
Deterministic	3,861,718



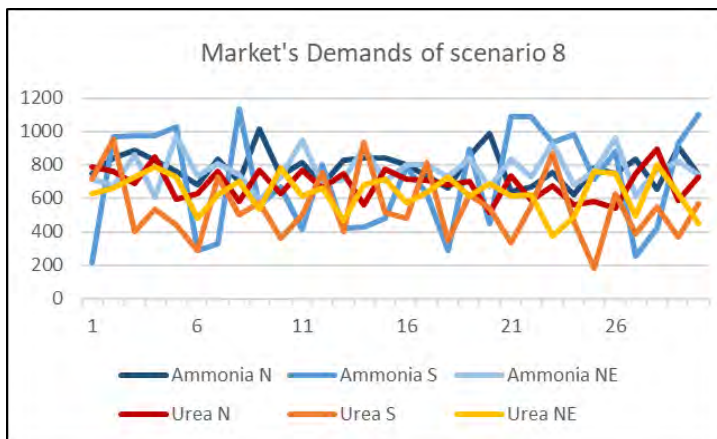
Supply chain	$\Sigma$ Profit in 30 days (\$)
No.12	4,412,096
No.13	4,344,521
Deterministic	4,176,433



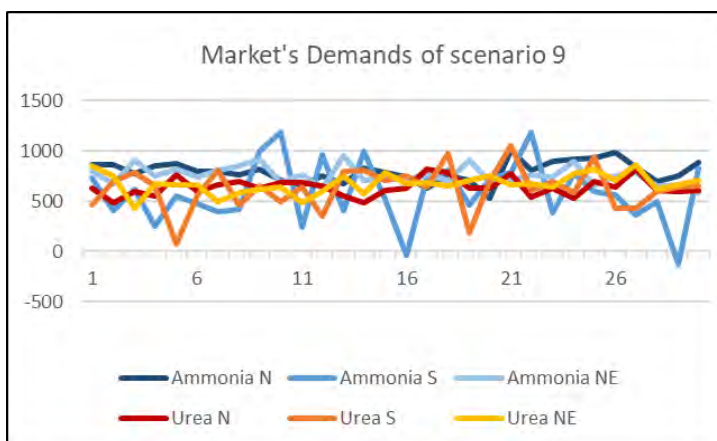
Supply chain	$\Sigma$ Profit in 30 days (\$)
No.12	3,956,282
No.13	4,078,928
Deterministic	3,723,418



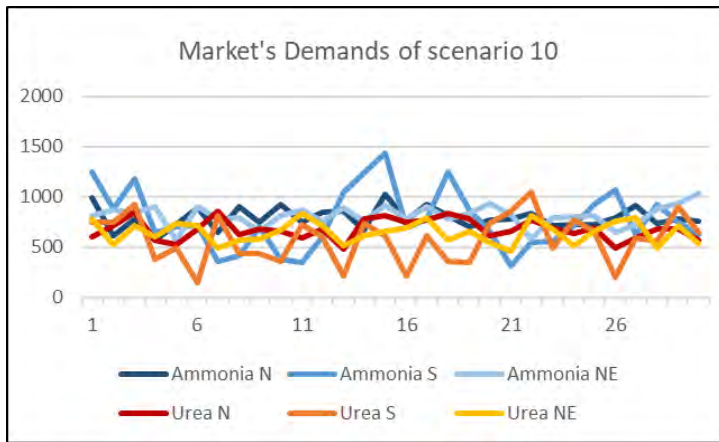
Supply chain	ΣProfit in 30 days (\$)
No.12	4,401,392
No.13	4,326,011
Deterministic	4,247,703



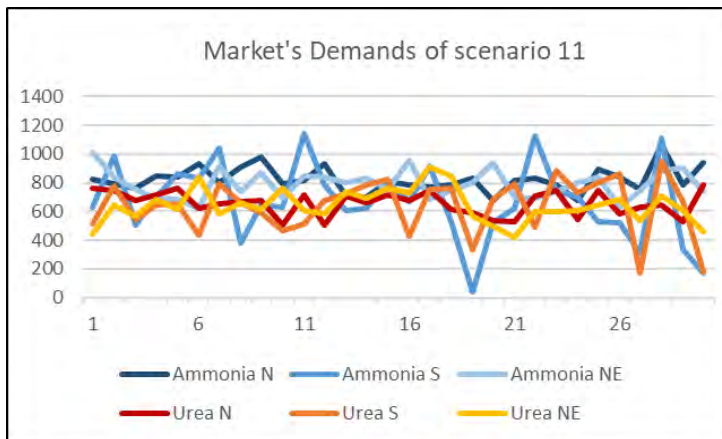
Supply chain	ΣProfit in 30 days (\$)
No.12	4,096,421
No.13	4,191,370
Deterministic	3,958,085



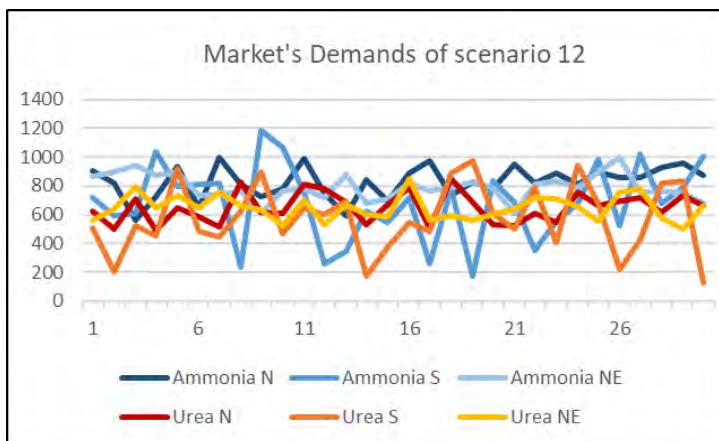
Supply chain	ΣProfit in 30 days (\$)
No.12	4,388,921
No.13	4,287,785
Deterministic	4,057,015



Supply chain	ΣProfit in 30 days (\$)
No.12	4,104,520
No.13	4,169,793
Deterministic	3,852,227



Supply chain	ΣProfit in 30 days (\$)
No.12	4,412,883
No.13	4,350,937
Deterministic	4,055,404



Supply chain	ΣProfit in 30 days (\$)
No.12	4,193,688
No.13	4,184,211
Deterministic	3,987,759

**Figure 4.18** The results from validation part of 12 scenarios – fixed production rate.

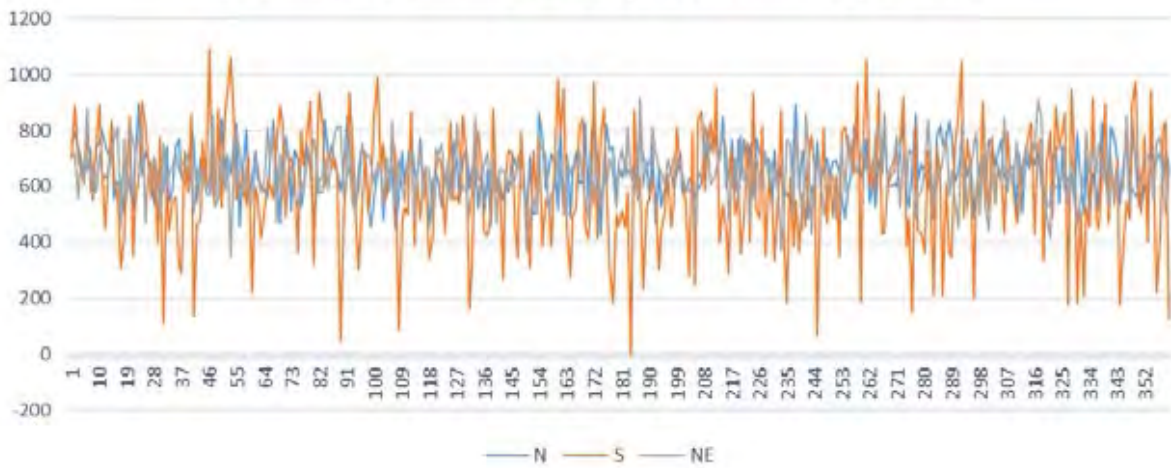


Ammonia Market's Demand of 30 day in 12 scenarios (360 days)



	N	S	NE
Mean	800	700	800
SD	100	300	100

Urea Market's Demand of 30 day in 12 scenarios (360 days)



	N	S	NE
Mean	650	500	650
SD	100	200	100

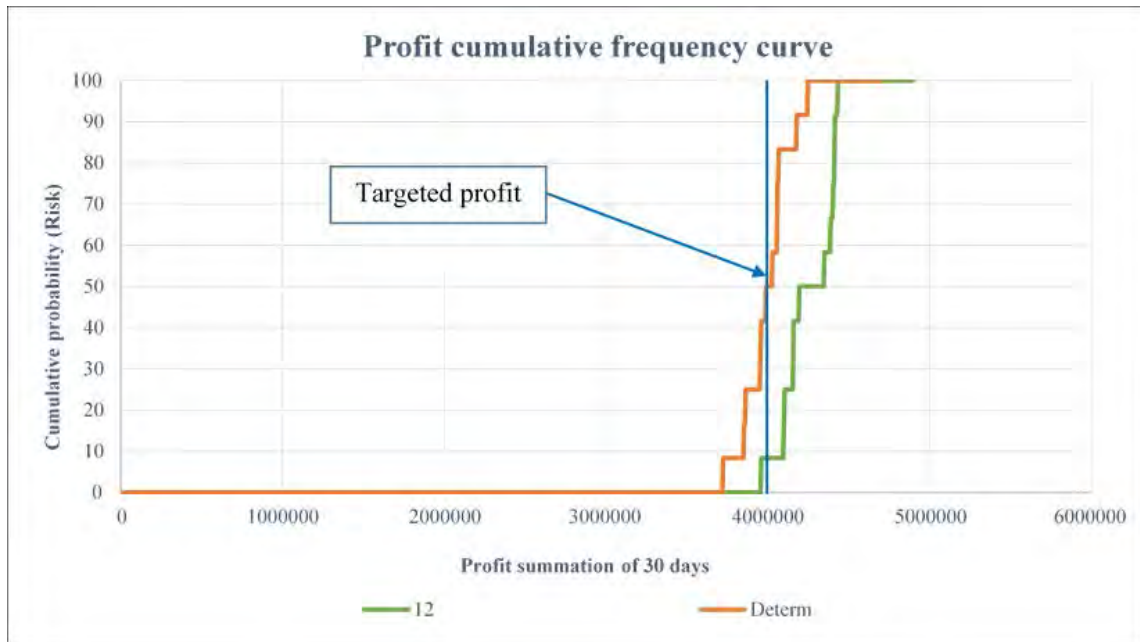
Figure 4.19 The new set of uncertainty market's demands of ammonia and urea in 12 scenarios, 30 days per scenarios (360 days) for validation part.

The optimized value of both ammonia and urea transportation of supply chain No.12 and No.13 in previous part are validated with new set of market's demands in 12 scenarios, 30 days per scenario. The summation of profit in 30 days of each scenarios were converted to profit cumulative frequency curve for evaluated the probability and upper limit profit of each supply chains as shown in figure 4.20

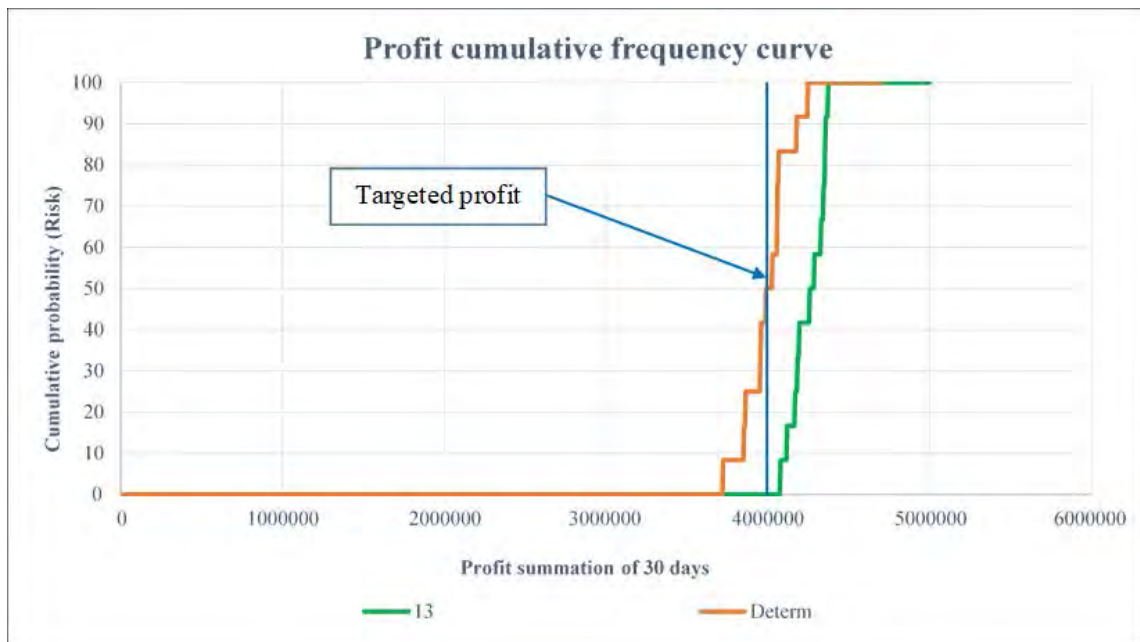
According to the profit cumulative frequency curve in figure 4.20a, at the targeted profit of \$ 4,000,000, the stochastic supply chain No.12 has 8.33 % risk giving profit less than targeted profit and its upper limit of profit is \$ 4,435,000. For figure 4.20b, the stochastic supply chain No.13 has 0 % risk giving profit less than targeted profit and its upper limit of profit is \$ 4,375,000 while the deterministic supply chain has higher risk of 50 % giving profit less than targeted profit and its upper limit of profit is \$ 4,250,000 lower than stochastic supply chains.



2619937106



**Figure 4.20a** profit cumulative frequency curve for supply chain No.12 and deterministic one.



**Figure 4.20b** profit cumulative frequency curve for supply chain No.13 and deterministic one.

#### 4.9 Investigation on Optimization of Market Demand (with Varied Production Capacity of Ammonia and Urea)

The optimization programming from part 4.8 is assumed to be fixed production capacity of ammonia and urea at 2,322 and 2,189 TPD, respectively. The penalty cost from opportunity loss and surplus production cost are presented from amount of products transportation that satisfy demanding of the markets. To improve the optimization programming, the ammonia/urea production capacity and urea production cost are adjusted to appropriate demand of markets. The mathematical model for designing the network is expressed as show below.

$$\text{Max } Z = \text{Price}_{\text{Amm}} * \sum_i \sum_j X_{ij} + \text{Price}_{\text{Urea}} \sum_i \sum_j Y_{ij} - [\text{Cost1} + \text{Cost2} + \text{Cost3}] \quad (6.1)$$

Subject to constraints,

$$\text{LimCapAmm}_i = \text{AmmIn}_i - \text{AmmFeed}_i \quad (6.8)$$

$$\text{LimCapUrea}_i = 1.4142 * \text{AmmFeed}_i - 0.014 \quad (6.9)$$

$$\sum_j X_{ij} = \text{LimCapAmm}_i \quad (6.10)$$

$$\sum_j Y_{ij} = \text{LimCapUrea}_i \quad (6.11)$$

$$\sum_i X_j + \sum_i \text{PenaltyAmm}_{ij} - \text{PPAmm}_j = \text{LimAmm}_j \text{ (Demand)} \quad (6.12)$$

$$\sum_i Y_{ij} + \sum_i \text{PenaltyUrea}_{ij} - \text{PPUrea}_j = \text{LimUrea}_j \text{ (Demand)} \quad (6.13)$$

$$\text{Cost1} = 635233 + \sum_i \text{LimCapUrea}_i * 73.184 - 1.21 \quad (6.14)$$

$$\text{Cost2} = (\sum_i \sum_j X_{ij} + \sum_i \sum_j Y_{ij}) * \text{transportcost} \quad (6.15)$$

$$\begin{aligned} \text{Cost3} = & \sum_i \sum_j \text{PenaltyAmm}_{ij} * \text{PAmmCost} + \sum_i \sum_j \text{PPAmm}_j * \text{PPAmmCost} + \\ & \sum_i \sum_j \text{PenaltyUrea}_{ij} * \text{PUreaCost} + \sum_i \sum_j \text{PPUrea}_j * \text{PPUreaCost} \end{aligned} \quad (6.16)$$



Where

$X_{ij}$  = Ammonia transportation amount (TPD)

$Y_{ij}$  = Urea transportation amount (TPD)

$LimCapAmm_i$  = Ammonia production capacity of plant i in cases (TPD)

$LimCapUrea_i$  = Urea production capacity of plant i in cases (TPD)

$AmmIn_i$  = Maximum ammonia production capacity of plant i in cases (TPD)

$AmmFeed_i$  = Ammonia amount which feed to produce urea (TPD)

$PenaltyAmm_{ij}$  = Ammonia amount which less than demand of market (TPD)

$PenaltyUrea_{ij}$  = Urea amount which less than demand of market (TPD)

$PPAmm_j$  = Ammonia amount which greater than demand of market (TPD)

$PPUrea_j$  = Urea amount which greater than demand of market (TPD)

$LimAmm_j$  (Demand) = Ammonia demand of market j in cases (TPD)

$LimUrea_j$  (Demand) = Urea demand of market j in cases (TPD)

Opportunity loss cost =  $\sum_i \sum_j$   $PenaltyAmm_{ij} * PAmmCost$  (\$/day)

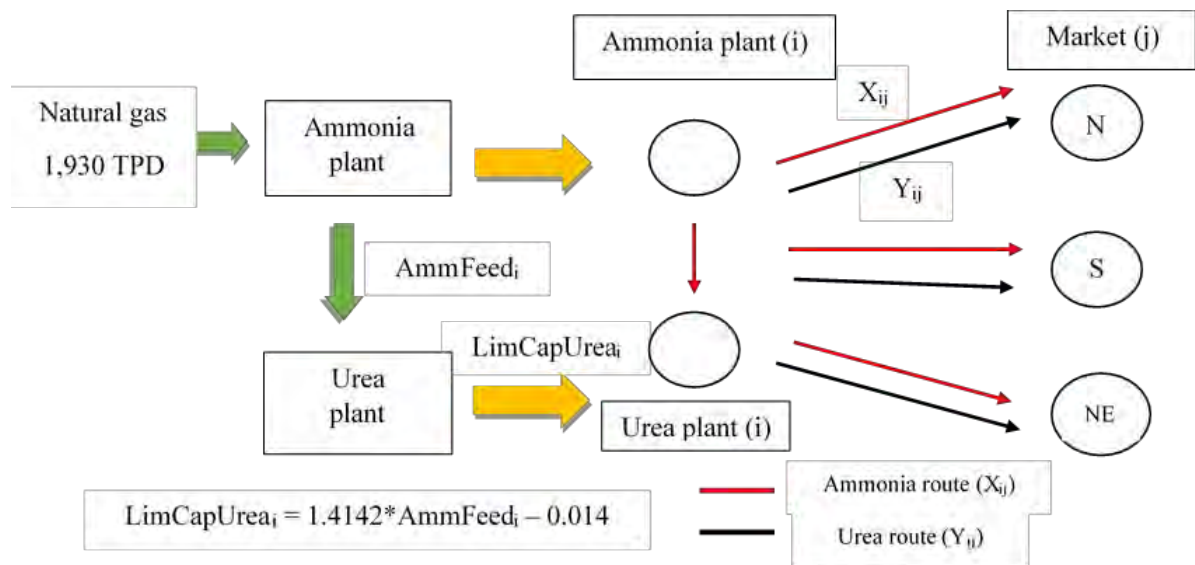
Surplus Production cost =  $\sum_i \sum_j$   $PPAmm_j * PPAmmCost$  (\$/day)

Cost1 = Ammonia and urea production cost (\$/day)

Cost2= Transportation cost (\$/day)

Cost3 = Penalty cost (\$/day)

The main objective of this model is to maximize profit from sale products. The objective function is expressed into 3 parts; revenue, transportation cost, and penalty cost as shown in equation 6.1. Equation 6.8 and 6.9 are deal with maximum capacity of plant in ammonia product and urea product, respectively. The urea capacity is from correlation between ammonia to urea product. Cost1, Production cost, is from ammonia which produced form natural gas feed 1,930 ton per day and urea production cost from urea utilities expenditure correlation with urea production function. The case study for deterministic and stochastic model for varied urea production can be divided into 30 days. The simple network with 2 echelons; Plant (i) and Market (j) with 2 products (ammonia and urea) is shown in figure 4.22 for varied production capacity.



**Figure 4.21** The simple network diagram for varied production capacity of ammonia and urea.

**Table 4.27** The result of supply chains model network – varied production capacity of ammonia and urea

Supply chain No.X using product demand of	Market (j) (TPD)			Penalty cost (\$)	Transportation cost (\$)	Profit Z (\$)
	N (j1)	S (j2)	NE (j3)			
No.1 using demand of day 1				27,600	101,575	198,259
Ammonia Demand	677	762	851			
Ammonia shipping amount (x)	677	762	851	0	52,885	
Urea Demand	687	581	634			
Urea shipping amount (y)	687	581	1,017	27,600	48,690	
No.2 using demand of day 2				17,559	107,912	159,275
Ammonia Demand	834	1,262	801			
Ammonia shipping amount (x)	834	1,092	801	17,559	67,803	
Urea Demand	478	632	558			
Urea shipping amount (y)	478	632	558	0	40,109	
No.3 using demand of day 3				110,608	83,180	190,757
Ammonia Demand	878	38	790			
Ammonia shipping amount (x)	878	38	790	0	32,827	
Urea Demand	575	366	634			
Urea shipping amount (y)	575	366	2,170	110,608	50,354	
No.4 using demand of day 4				37,649	99,090	194,607
Ammonia Demand	777	700	773			
Ammonia shipping amount (x)	777	700	773	0	52,609	
Urea Demand	614	513	692			
Urea shipping amount (y)	614	513	1,215	37,649	46,481	
No.5 using demand of day 5				22,000	46,673	197,583
Ammonia Demand	828	758	759			
Ammonia shipping amount (x)	828	758	759	0	55,801	
Urea Demand	621	575	706			
Urea shipping amount (y)	621	575	1,012	22,000	46,673	

**Table 4.27** The result of supply chains model network – varied production capacity of ammonia and urea (continue)

Supply chain No.X using product demand of	Market (j) (TPD)			Penalty cost (\$)	Transportation cost (\$)	Profit Z (\$)
	N (j1)	S (j2)	NE (j3)			
No.6 using demand of day 6				15,657	101,432	198,806
Ammonia Demand	987	637	784			
Ammonia shipping amount (x)	987	637	784	0	56,144	
Urea Demand	712	494	695			
Urea shipping amount (y)	712	494	912	15,657	45,288	
No.7 using demand of day 7				14,066	104,256	207,939
Ammonia Demand	790	711	801			
Ammonia shipping amount (x)	790	711	801	0	53,621	
Urea Demand	640	702	731			
Urea shipping amount (y)	640	702	926	14,066	50,635	
No.8 using demand of day 8				44,216	99,538	179,378
Ammonia Demand	911	675	748			
Ammonia shipping amount (x)	911	675	748	0	55,051	
Urea Demand	623	475	511			
Urea shipping amount (y)	623	475	1,125	44,216	44,487	
No.9 using demand of day 9				12,471	108,766	210,891
Ammonia Demand	825	674	743			
Ammonia shipping amount (x)	825	674	743	0	52,682	
Urea Demand	771	805	604			
Urea shipping amount (y)	771	805	777	12,471	56,084	
No.10 using demand of day 10				18,794	105,928	189,067
Ammonia Demand	888	829	895			
Ammonia shipping amount (x)	888	647	895	18,794	54,996	
Urea Demand	723	737	628			
Urea shipping amount (y)	723	737	628	0	50,932	

**Table 4.27** The result of the supply chains model network – varied production capacity of ammonia and urea (continue)

Supply chain No.X using product demand of	Market (j) (TPD)			Penalty cost (\$)	Transportation cost (\$)	Profit Z (\$)
	N (j1)	S (j2)	NE (j3)			
No.11 using demand of day 11				49,004	100,184	210,420
Ammonia Demand	782	288	891			
Ammonia shipping amount (x)	782	288	891	0	39,878	
Urea Demand	750	823	497			
Urea shipping amount (y)	750	823	1,178	49,004	60,306	
No.12 using demand of day 12				5,973	103,994	209,351
Ammonia Demand	836	680	857			
Ammonia shipping amount (x)	836	680	857	0	54,365	
Urea Demand	694	667	724			
Urea shipping amount (y)	694	667	807	5,973	49,629	
No.13 using demand of day 13				9,798	109,187	192,521
Ammonia Demand	770	956	822			
Ammonia shipping amount (x)	770	861	822	9,798	58,434	
Urea Demand	798	693	564			
Urea shipping amount (y)	798	693	564	0	50,753	
No.14 using demand of day 14				47,555	94,993	179,019
Ammonia Demand	743	791	816			
Ammonia shipping amount (x)	743	791	816	0	55,265	
Urea Demand	701	232	607			
Urea shipping amount (y)	701	232	1,267	47,555	39,728	
No.15 using demand of day 15				33,414	99,857	210,396
Ammonia Demand	815	667	642			
Ammonia shipping amount (x)	815	667	642	0	51,126	
Urea Demand	528	588	940			
Urea shipping amount (y)	528	588	1,404	33,414	48,731	

**Table 4.27** The result of the supply chains model network – varied production capacity of ammonia and urea (continue)

Supply chain No.X using product demand of	Market (j) (TPD)			Penalty cost (\$)	Transportation cost (\$)	Profit Z (\$)
	N (j1)	S (j2)	NE (j3)			
No.16 using demand of day 16				22,964	100,196	198,304
Ammonia Demand	812	722	1040			
Ammonia shipping amount (x)	812	499	1040	22,964	49,442	
Urea Demand	779	643	777			
Urea shipping amount (y)	779	643	777	0	50,754	
No.17 using demand of day 17				9,145	105,221	181,167
Ammonia Demand	935	999	771			
Ammonia shipping amount (x)	935	910	771	9,145	63,972	
Urea Demand	653	493	678			
Urea shipping amount (y)	653	493	678	0	41,249	
No.18 using demand of day 18				49,199	98,140	210,313
Ammonia Demand	776	439	766			
Ammonia shipping amount (x)	776	439	766	0	43,583	
Urea Demand	676	644	719			
Urea shipping amount (y)	676	644	1,402	49,199	54,557	
No.19 using demand of day 19				44,195	100,107	200,246
Ammonia Demand	997	375	743			
Ammonia shipping amount (x)	997	375	743	0	47,023	
Urea Demand	701	648	570			
Urea shipping amount (y)	701	648	1,184	44,195	53,085	
No.20 using demand of day 20				5,939	107,822	207,773
Ammonia Demand	751	815	842			
Ammonia shipping amount (x)	751	757	842	5,939	54,597	
Urea Demand	588	876	736			
Urea shipping amount (y)	588	876	736	0	53,225	

**Table 4.27** The result of the supply chains model network – varied production capacity of ammonia and urea (continue)

Supply chain No.X using product demand of	Market (j) (TPD)			Penalty cost (\$)	Transportation cost (\$)	Profit Z (\$)
	N (j1)	S (j2)	NE (j3)			
No.21 using demand of day 21				22,998	99,461	191,773
Ammonia Demand	932	625	868			
Ammonia shipping amount (x)	932	625	868	0	55,147	
Urea Demand	679	486	610			
Urea shipping amount (y)	679	486	929	22,998	44,315	
No.22 using demand of day 22				43,613	98,788	189,141
Ammonia Demand	887	578	783			
Ammonia shipping amount (x)	887	578	783	0	51,461	
Urea Demand	613	548	578			
Urea shipping amount (y)	613	548	1,184	43,613	47,328	
No.23 using demand of day 23				5,210	102,995	208,374
Ammonia Demand	864	633	904			
Ammonia shipping amount (x)	864	633	904	0	53,989	
Urea Demand	731	633	692			
Urea shipping amount (y)	731	633	764	5,210	49,006	
No.24 using demand of day 24				58,443	92,191	201,444
Ammonia Demand	612	599	827			
Ammonia shipping amount (x)	612	599	827	0	45,335	
Urea Demand	674	357	799			
Urea shipping amount (y)	674	357	1,611	58,443	46,856	
No.25 using demand of day 25				26,501	98,895	179,546
Ammonia Demand	955	844	721			
Ammonia shipping amount (x)	955	844	721	0	61,718	
Urea Demand	605	295	692			
Urea shipping amount (y)	605	295	1,060	26,501	37,176	

**Table 4.27** The result of the supply chains model network – varied production capacity of ammonia and urea (continue)

Supply chain No.X using product demand of	Market (j) (TPD)			Penalty cost (\$)	Transportation cost (\$)	Profit Z (\$)
	N (j1)	S (j2)	NE (j3)			
No.26 using demand of day 26				34,111	95,090	194,321
Ammonia Demand	913	509	908			
Ammonia shipping amount (x)	913	509	908	0	51,091	
Urea Demand	766	355	634			
Urea shipping amount (y)	766	355	1,108	34,111	43,999	
No.27 using demand of day 27				56,521	95,900	197,604
Ammonia Demand	627	610	822			
Ammonia shipping amount (x)	627	610	822	0	46,058	
Urea Demand	769	431	627			
Urea shipping amount (y)	769	431	1,412	56,521	49,842	
No.28 using demand of day 28				53,538	96,903	196,650
Ammonia Demand	726	677	686			
Ammonia shipping amount (x)	726	677	686	0	49,563	
Urea Demand	830	303	693			
Urea shipping amount (y)	830	303	1,437	53,538	47,340	
No.29 using demand of day 29				43,094	95,172	184,963
Ammonia Demand	690	772	871			
Ammonia shipping amount (x)	690	772	871	0	53,780	
Urea Demand	485	438	703			
Urea shipping amount (y)	485	438	1,302	43,094	41,392	
No.30 using demand of day 30				2,829	108,250	221,539
Ammonia Demand	580	756	901			
Ammonia shipping amount (x)	580	756	901	0	50,625	
Urea Demand	716	904	701			
Urea shipping amount (y)	716	904	740	2,829	57,626	



**Table 4.27** The result of the supply chains model network – varied production capacity of ammonia and urea (continue)

Supply chain No.X using product demand of	Market (j) (TPD)			Penalty cost (\$)	Transportation cost (\$)	Profit Z (\$)
	N (j1)	S (j2)	NE (j3)			
Deterministic using average demand				25,971	101,121	188,795
Ammonia Demand	813	679	814			
Ammonia shipping amount (x)	813	679	814	0	53,273	
Urea Demand	673	565	664			
Urea shipping amount (y)	673	565	1,025	25,971	47,848	



2619937106

From Table 4.27, The optimal ammonia shipping amount (x) and urea shipping amount (y) are represented for 30 days. There are 30 supply chains both ammonia and urea. The products shipping amount both ammonia and urea (x and y) which are transported greater than demand of the market (j) or oversupply will be sold with cheaper selling price about 25% of product selling price. The products which are transported lower than demand of the market (j) or lacked product will have penalty cost about 50% of product selling price. The transportation cost is from the distance between plant and market and amount of product which transported to the market. The distance between plant and markets N(j1), S(j2), and NE(j3) are assumed as 531, 684, 208 miles, respectively. The transportation cost is 0.05\$/tons/miles as shown in table 4.24. These conditions are made for programming optimization. In this part, 6.9 Investigation on Optimization of Market Demand (with Varied Production Capacity of Ammonia and Urea), The capacity of ammonia has maximum with 3,870 TPD from natural gas feedstock of 1,930 TPD. The correlation between ammonia feed to urea production capacity is  $LimCapUrea_i = 1.4142 * AmmFeed_i - 0.014$  as shown in equation (6.9). The adjustable of product capacity both ammonia and urea can increase optimal values in terms of products transportation meet the specification of market's demand and can increasing profit of plant.

For deterministic optimization method, the average demand of market in 30 days are considered for optimal ammonia and urea transportation for maximizing profit. The average of ammonia demands in 3 markets N(j1), S(j2), NE(j3) are 813, 679, and 814 TPD, respectively. The average of urea demands in 3 markets N(j1), S(j2) and NE(j3) are 673, 565, and 664 TPD, respectively. The demands and average of each market are represented in Table 4.27. The summation of profit in 30 days for deterministic optimization method is \$ 4,610,028 as shown in table 4.28.

**Table 4.28** The optimal value of Ammonia and Urea for 30 days – varied ammonia and urea production rate (historical)

Supply chain No.	Ammonia			Urea			ΣProfit in 30 days
	N(j1)	S(j2)	NE(j3)	N(j1)	S(j2)	NE(j3)	
1	677	762	851	687	581	1,017	4,474,415
2	834	1,092	801	478	632	558	2,582,525
3	878	38	790	575	366	2,170	2,075,029
4	777	700	773	614	513	1,215	4,155,399
5	828	758	759	621	575	1,012	4,398,067
6	987	637	784	712	494	912	4,303,131
7	790	711	801	640	702	926	4,683,721
8	911	675	748	623	475	1125	4,017,636
9	825	674	743	771	805	777	4,850,215
10	888	647	895	723	737	628	4,581,932
11	782	288	891	750	823	1,178	4,246,215
12	836	680	857	694	667	807	4,863,511
13	770	861	822	798	693	564	4,141,595
14	743	791	816	701	232	1,267	3,099,781
15	815	667	642	528	588	1,404	3,564,999
16	812	499	1040	779	643	777	4,473,759
17	935	910	771	653	493	678	3,843,946
18	776	439	766	676	644	1,402	4,293,763
19	997	375	743	701	648	1,184	4,074,405
20	751	757	842	588	876	736	4,360,092
21	932	625	868	679	486	929	4,319,067
22	887	578	783	613	548	1,184	4,179,456
23	864	633	904	731	633	764	4,806,255
24	612	599	827	674	357	1,611	3,360,171
25	955	844	721	605	295	1,060	2,880,120
26	913	509	908	766	355	1,108	3,690,985
27	627	610	822	769	431	1,412	3,898,627
28	726	677	686	830	303	1,437	3,273,245
29	690	772	871	485	438	1,302	3,080,003
30	580	756	901	716	904	740	4,388,508
Deterministic	813	679	814	673	565	1,025	4,610,028

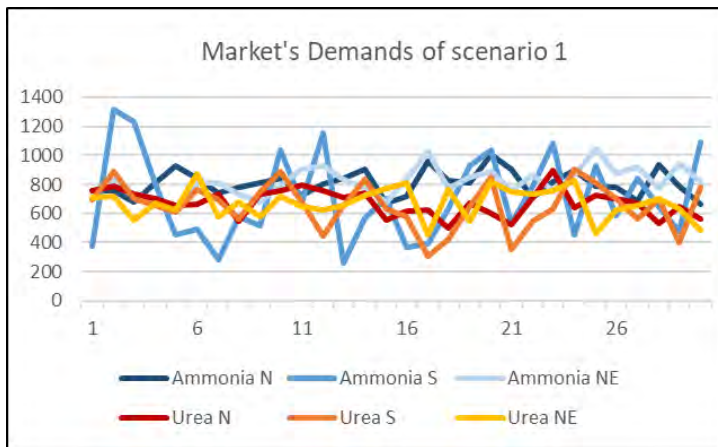
For stochastic optimization method, the demands of the market in 30 days are considered for optimal ammonia and urea transportation amount for maximizing profit as the previous part. To deal with uncertainties occurred due to randomness, stochastic optimization method was conducted. The demands of produces each day were considered for programming optimization. In stochastic method, there are 30 supply chains with 30 optimal values of ammonia and urea transporting amount for each day in 30 days. These values of each supply chains are used for products transportation all 30 days and assessment summation profit of each supply chains. The ammonia and urea transportation amount and profit summation of each supply chains are represented in table 4.28. The difference of profit in 30 days of each supply chains are from differential amount of products transportation and the transported products which not satisfy market's demand of each day. From supply chain No.9, No 12, and No.23 give the optimal values for all 30 days which higher profit compare with other supply chains.

The validation part is created from new set of uncertainty demands of ammonia and urea by using the same statistic value of mean and standard deviation as the historical data as shown in the figure 4.19. The mean of ammonia demand of 3 markets N(j1), S(j2), and NE (j3) are 800, 700, and 800 TPD and the standard deviation are 100, 300, and 100, respectively. The mean of urea demand of 3 markets N(j1), S(j2), and NE(j3) are 650, 500, and 650 TPD and the standard deviation are 100, 200, and 100, respectively. In validation part, the new set of market's demands are divided into 12 scenarios, 30 days per scenarios (all 360 days of various data) as same as part 6.8.

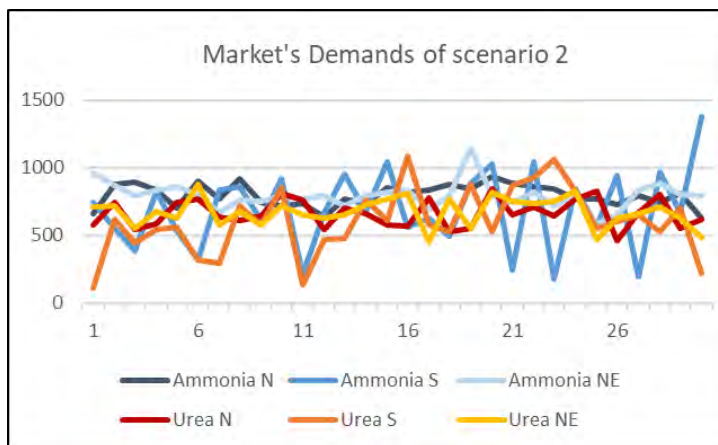


2619937106

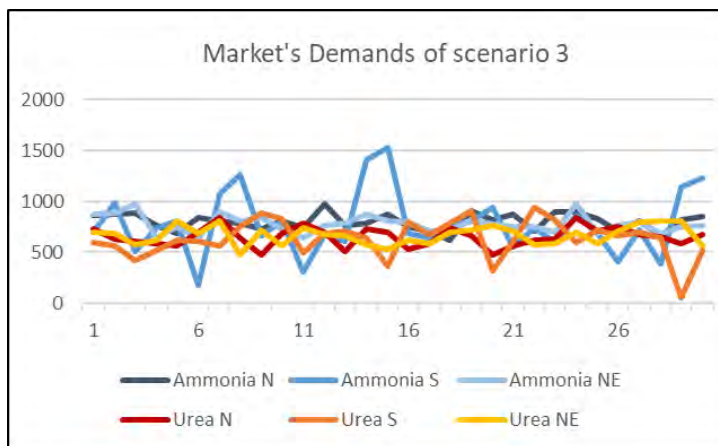
CU IThesis 6173002063 thesis / recv: 20072563 10:48:08 / seq: 18



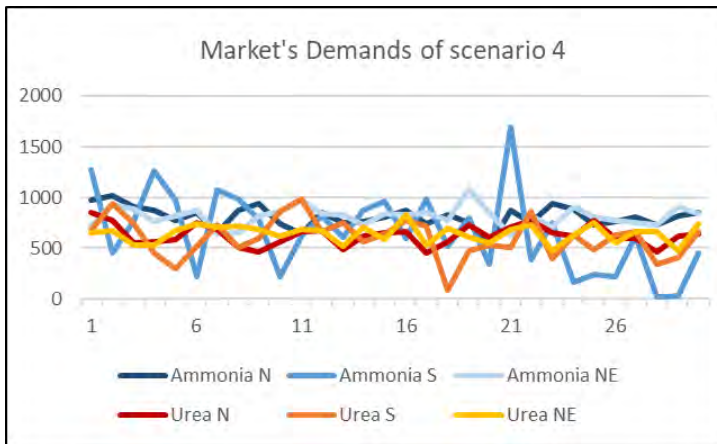
Supply chain	ΣProfit in 30 days (\$)
No.9	4,752,336
No.12	4,636,669
No.23	4,544,178
Deterministic	4,217,781



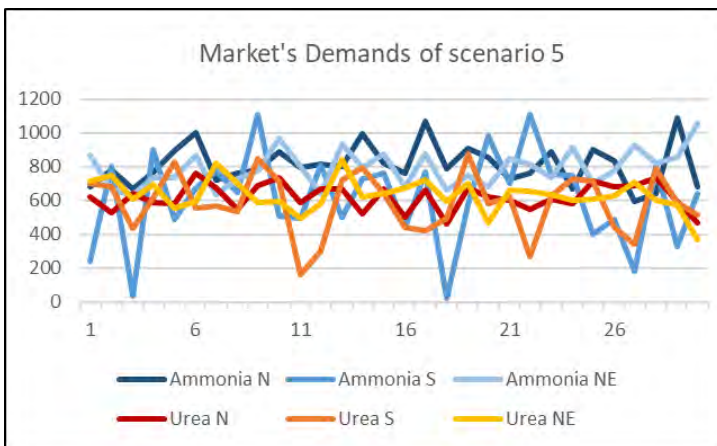
Supply chain	ΣProfit in 30 days (\$)
No.9	4,542,493
No.12	4,385,549
No.23	4,309,481
Deterministic	4,155,869



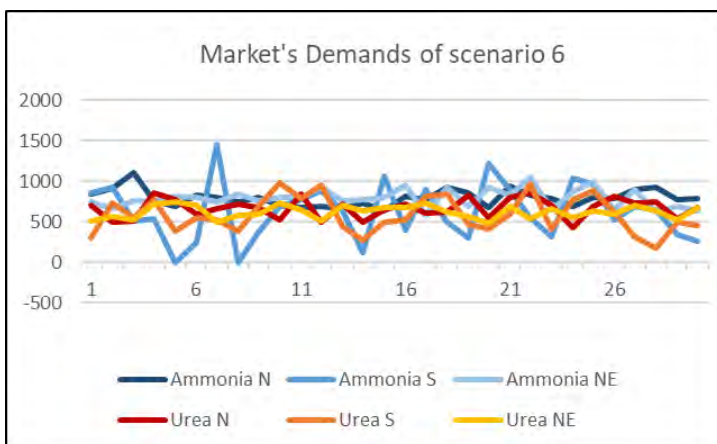
Supply chain	ΣProfit in 30 days (\$)
No.9	4,739,650
No.12	4,610,258
No.23	4,432,352
Deterministic	4,271,919



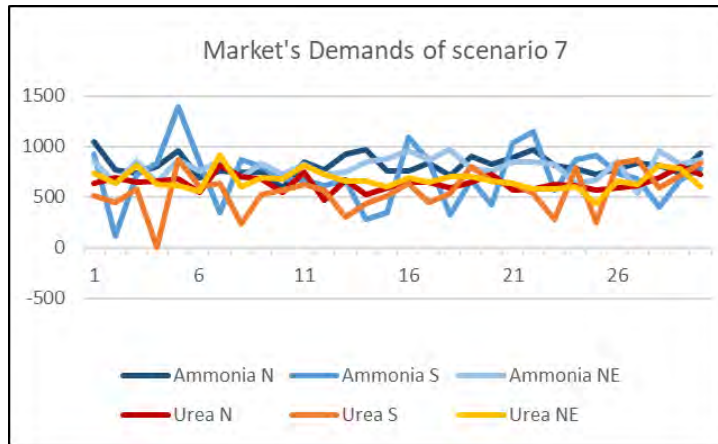
Supply chain	$\Sigma$ Profit in 30 days (\$)
No.9	4,349,496
No.12	4,362,289
No.23	4,289,086
Deterministic	4,046,277



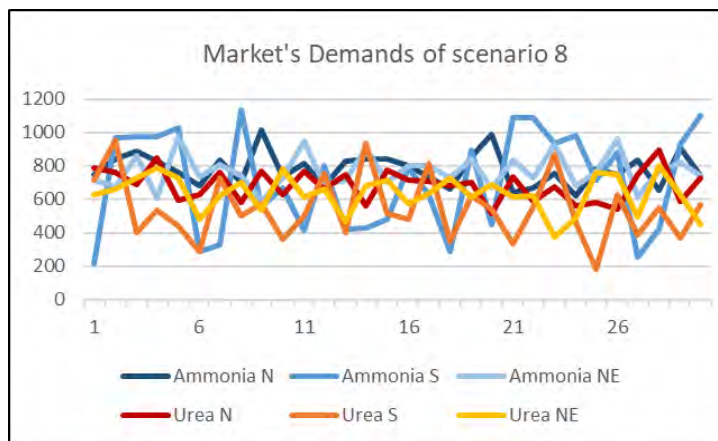
Supply chain	$\Sigma$ Profit in 30 days (\$)
No.9	4,622,828
No.12	4,628,223
No.23	4,519,803
Deterministic	4,371,670



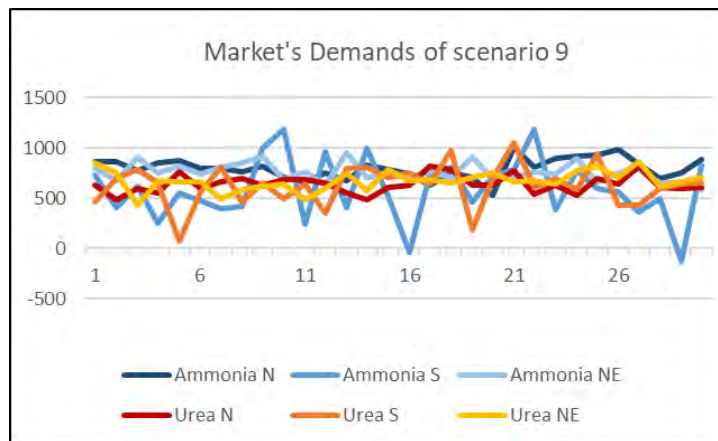
Supply chain	$\Sigma$ Profit in 30 days (\$)
No.9	4,373,627
No.12	4,162,503
No.23	4,148,803
Deterministic	3,923,030



Supply chain	ΣProfit in 30 days (\$)
No.9	4,572,972
No.12	4,652,777
No.23	4,503,266
Deterministic	4,429,242

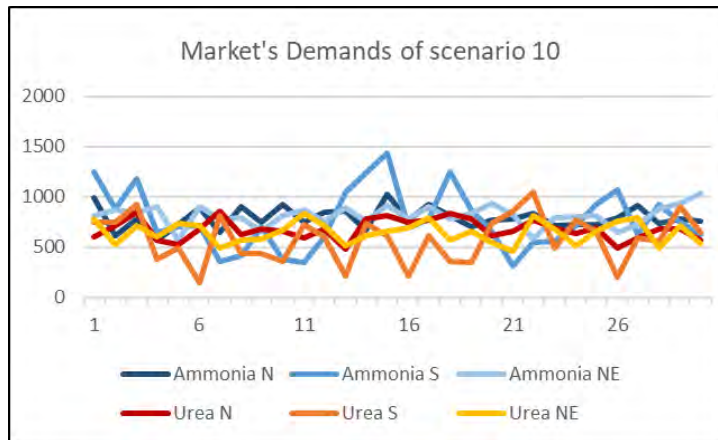


Supply chain	ΣProfit in 30 days (\$)
No.9	4,487,103
No.12	4,328,850
No.23	4,292,671
Deterministic	4,160,601

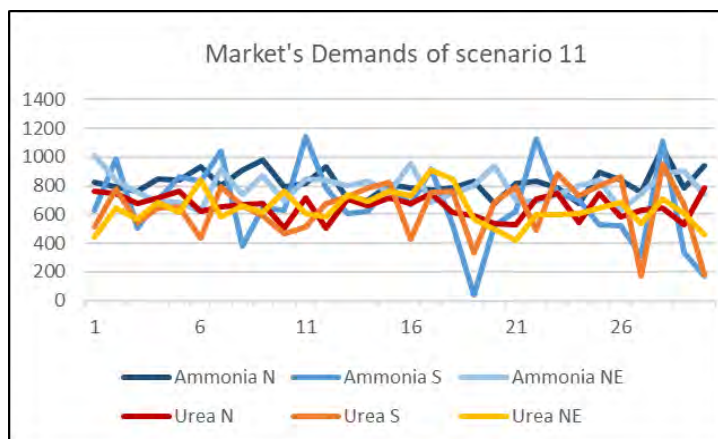


Supply chain	ΣProfit in 30 days (\$)
No.9	4,738,893
No.12	4,571,620
No.23	4,451,390
Deterministic	4,265,565

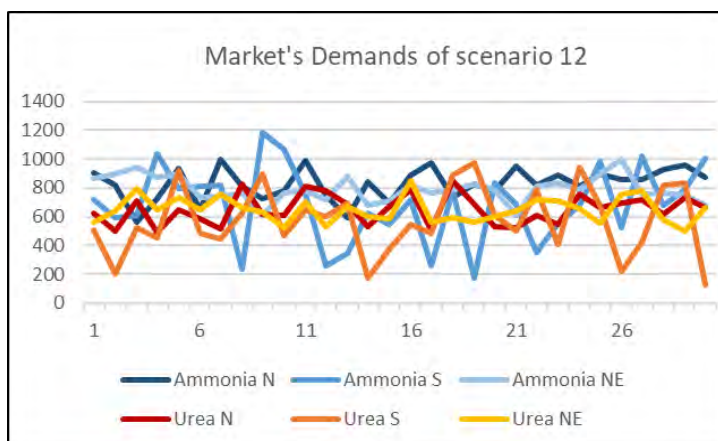




Supply chain	ΣProfit in 30 days (\$)
No.9	4,417,995
No.12	4,347,503
No.23	4,246,138
Deterministic	4,041,861



Supply chain	ΣProfit in 30 days (\$)
No.9	4,816,588
No.12	4,612,233
No.23	4,494,434
Deterministic	4,249,583



Supply chain	ΣProfit in 30 days (\$)
No.9	4,545,867
No.12	4,430,984
No.23	4,358,699
Deterministic	4,186,478

Figure 4.22 The results from validation part of 12 scenarios – varied production rate.

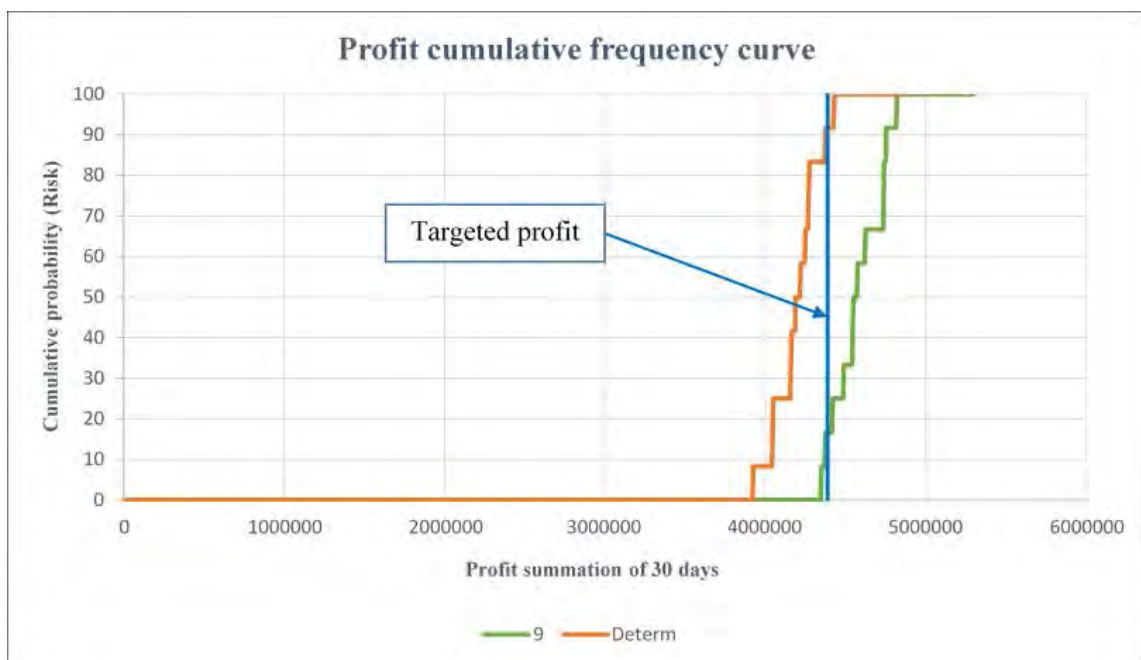
2619937106

CD IThesis 6173002063 thesis / rev: 20072563 10:48:08 / seq: 18



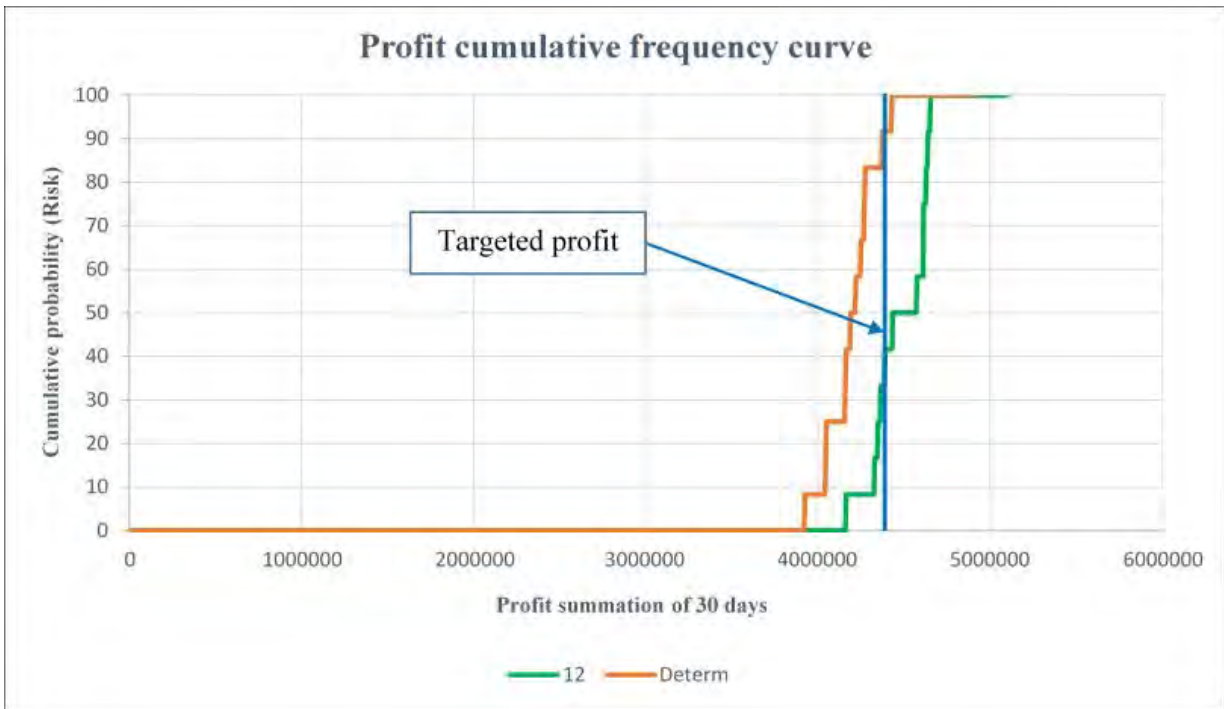
The optimized value of both ammonia and urea transportation of supply chain No.9, No.12, and No.23 in part 6.9 are validated with new set of market's demands in 12 scenarios, 30 days per scenarios. The summation of profit in 30 days of each scenarios were converted to profit cumulative frequency curve for evaluated the probability and upper limit profit of each supply chains as shown in figure 4.23.

According to the profit cumulative frequency curve in figure 4.23a, at targeted profit of \$ 4,400,000, the stochastic supply chain No.9 has 16.67 % risk giving profit less than targeted profit and its upper limit profit is \$ 4,820,000 . According to the profit cumulative frequency curve in figure 4.23b, the stochastic supply chain No.12 has 41.67 % risk giving profit less than targeted profit and its upper limit profit is \$ 4,655,000 . According to the profit cumulative frequency curve in figure 4.23c, the stochastic supply chain No.23 has 50 % risk giving profit less than targeted profit and its upper limit profit is \$ 4,545,000 while the deterministic supply chain has higher risk of 91.67 % giving profit less than targeted profit and its upper limit of profit is \$ 4,430,000 lower than stochastic supply chains.

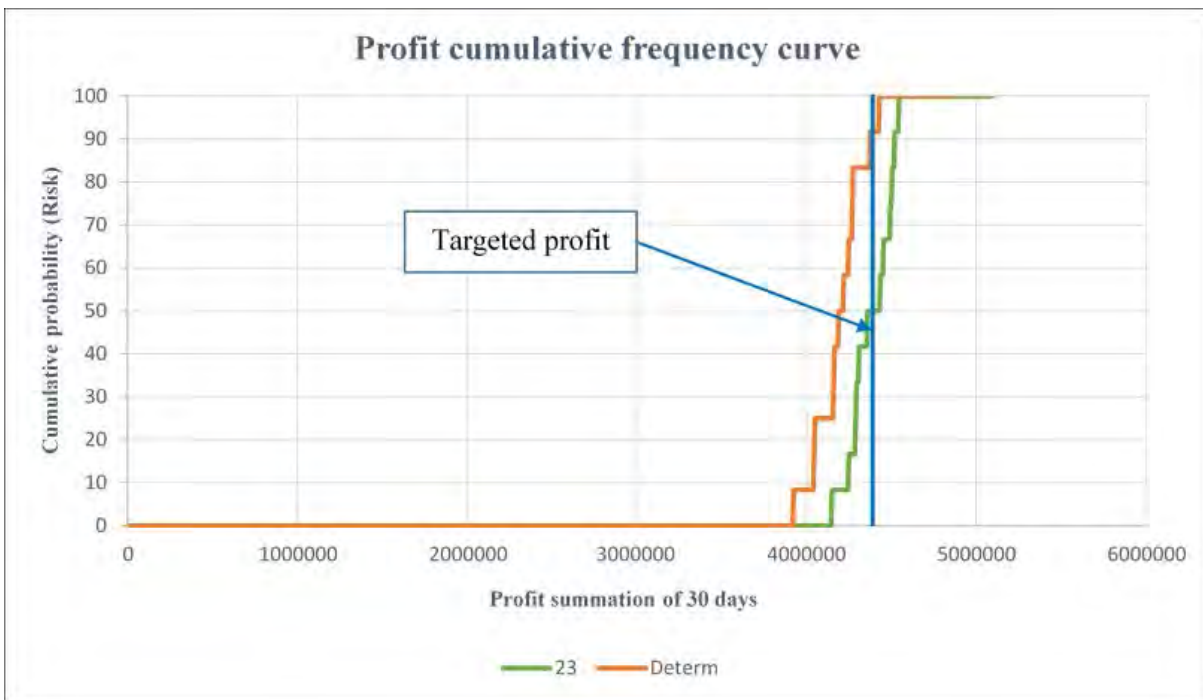


**Figure 4.23** Profit cumulative frequency curve for stochastic supply chains No.9 and deterministic one – varied production capacity.

2619937106  
 CD IThesis 6173002063 thesis / rev: 20072563 10:48:08 / seq: 18



**Figure 4.23b** Profit cumulative frequency curve for stochastic supply chains No.12 and deterministic one – varied production capacity.



**Figure 4.23c** Profit cumulative frequency curve for stochastic supply chains No.23 and deterministic one – varied production capacity.

According to the result, the adjusting of ammonia and urea production rate can give higher profit in both of deterministic and stochastic method compared with fixed products production rate as a result of products satisfy market's demands and can decreasing excess costs from product transportation, lacked product penalty cost, and oversupply product sold with cheaper selling price. From the deterministic method, the optimization of ammonia and urea transportation are using single fixed value of average from markets demands in 30 days. To provide the upper and lower limit of profit, scenario analysis is performed with various demand from each market. Stochastic analysis method is dealing with uncertain market's demands, in this research assume to be the historical data. For all studied cases, it was also found that the optimization with stochastic analysis method give the optimal value or higher profit compared with deterministic analysis using the same data.



2619937106

CU iThesis 6173002063 thesis / recv: 20072563 10:48:08 / seq: 18

## CHAPTER 5

### CONCLUSION

According to the results of this research, ammonia and urea manufacturing process are done by Pro II simulation programming. Ammonia production is a significant material used in a production of urea by reacting with CO<sub>2</sub>. This conceptual plant applied ammonia and urea processes can be more efficient in the production of urea, where by-products of each process can be used to produce more urea and reduce CO<sub>2</sub> emission. From 1,930 t/d of natural gas feed, the production capacity of the ammonia process is 3,870 TPD and the production capacity of the urea process is 5,472 TPD. From energy consumption and economic assessment, the capital expenditure (CAPEX) of overall process is 233,988,848 \$. The most operating expenditure of overall process is 45 % from electricity. Improving this section can highly effect on economic of the process. The operating expenditure of urea process can be varied with energy consumption changed due to amount of ammonia feed and urea production rate. Therefore, the correlation between urea production and ammonia feed is essentially considered. For case of varied ammonia and urea production rate, the maximum 30-days profit of \$ 4,863,511 from stochastic supply chain No.12 and 30-days profit of \$ 4,610,028 from deterministic supply chain are higher than the ones from case of fixed ammonia and urea production rate, where the maximum 30-days profit of \$ 4,622,681 from stochastic supply chain No.13 and 30-days profit of \$ 4,417,229 from deterministic supply chain. According to the results of supply chains optimization, the adjusting of ammonia and urea production rate give higher profit in both of stochastic and deterministic method compared with fixed production rate as a result of products satisfy market's demands. For stochastic analysis, the validation part approves that optimization with stochastic method provided optimal value compared with deterministic method using identical data. The profit cumulative curve show that stochastic method provides supply chain with a lower risk to achieve profit less the targeted one than deterministic method at same targeted profit. However, consideration of both deterministic and stochastic analyses can provide more effective results.

**Table 5.1** Concluded information and key parameters of manufacturing process

No.	Description	results
Ammonia manufacturing process		
1	Ammonia capacity	3,870 TPD
2	Raw materials	Hydrogen from Natural gas, Nitrogen from Air
3	Process Units	22 units
4	Overall Energy Consumption	3,585 MMKJ/hr. $9.49 \times 10^4$ kW
5	Annual Operating Expenditure (OPEX)	231,860,129 \$
6	Product specifications	Ammonia purity 99.90 % Temperature -33.3 °C Pressure 320 psia
Urea manufacturing process		
7	Urea capacity	5,472 TPD
8	Raw materials	Ammonia, Carbon dioxide
9	Process Units	21 units
10	Overall Energy Consumption	Hot utilities 427 MMKJ/hr. Cold utilities 493 MMKJ/hr. Shaft work $9.52 \times 10^4$ kW
11	Annual Operating Expenditure (OPEX)	146,182,569 \$
12	Product specifications	Granulated urea purity 99.90 % Temperature 93.33 °C
Techno economic assessment		
13	Plant lifetime	10 years
14	Overall Capital Expenditure (CAPEX)	233,988,848 \$
15	Products price	Ammonia 206 \$/ton Urea 288 \$/ton
16	Payback period	5.4 year (at 10 % interest)
17	Net present value	197,175,232 \$

**Table 5.2** Concluded information and key parameters of supply chain optimization

	Ammonia (t/d)			Urea (t/d)			Ammonia production rate (t/d)	Urea production rate (t/d)	Σ Profit in 30 days (\$)
	(j1)	(j2)	(j3)	(j1)	(j2)	(j3)			
Average	813	679	814	673	565	664			
Mean	800	700	800	650	500	650			
SD	100	300	100	100	200	100			
Fixed production rate									
Deterministic	813	679	830	673	565	951	2,322	2,189	4,417,229
Stochastic No.12	836	629	857	694	667	828	2,322	2,189	4,619,053
Stochastic No.13	770	730	822	798	693	698	2,322	2,189	4,622,681
Varied production rate									
Deterministic	813	679	814	673	565	1,025	2,306	2,263	4,610,028
Stochastic No.9	825	674	743	771	805	777	2,242	2,353	4,850,215
Stochastic No.12	836	680	857	694	667	807	2,373	2,168	4,863,511
Stochastic No.23	864	633	904	731	633	764	2,401	2,128	4,806,255

## APPENDICES

### Appendix A

GAMS programing of ammonia and urea plant with improved deterministic supply chain under fixed production rate

```
Sets
  i  plants / i1 /
  j  markets / j1, j2, j3 / ;

Parameters

  limcapam(i)  capacity of plant i in cases
  /   i1 =   2322 /
  limcapur(i)  capacity of plant i in cases
  /   i1 =   2189 /

  limam(j)     demand at market j in cases
  /   j1=813, j2=679, j3=814 /
  limur(j)     demand at market j in cases
  /   j1=673, j2=565, j3=664 / ;

Table d(i,j)  distance in miles
           j1      j2      j3
  i1      531      684      208  ;

Scalar f  freight in dollars per case per thousand miles /0.05/ ;
Scalar costl  production cost /795470/;
Scalar Ammprice  Ammonia sale price /206/;
Scalar PAmmcost  production cost /103/;
Scalar PPAmmcost  production cost /51.5/;
Scalar Urprice  Urea sale price /288/;
Scalar PUrcost  production cost /144/;
Scalar PPUrcost  production cost /72/;

Parameter c(i,j)  transport cost in dollars per case ;

  c(i,j) = f * d(i,j)  ;
```



2619937106

CU IThesis 6173002063 thesis / rev: 20072563 10:48:08 / seq: 18

```

variables x(i,j)  Ammonia sale product
            y(i,j)  Urea sale product
            cost2   logistic cost
            cost3   Penalty cost
            PAmm(i,j) lack Ammonia
            PPAmn(j) Waste Ammonia
            PUr(i,j)  lack Urea
            PPUr(j)   Waste Urea
            z         Profit ;

positive variable x,y, PAmm, PPAmn, PUr, PPUr;

equation con1(i);
con1(i).. sum(j, x(i,j)) =e= limcapam(i);

equation con2(i);
con2(i).. sum(j, y(i,j)) =e= limcapur(i) ;

equation con3(j);
con3(j).. sum(i,x(i,j))+ sum(i,PAmm(i,j))-PPAmn(j) =e= limam(j);

equation con4(j);
con4(j).. sum(i,y(i,j))+ sum(i,PUr(i,j))-PPUr(j) =e= limur(j);

equation con5 logistic cost;
con5 .. cost2 =e= sum((i,j),c(i,j)*(x(i,j)))+ sum((i,j),c(i,j)*(y(i,j)));

equation con7 Penalty cost;
con7 .. cost3 =e= sum((i,j),PAmmcost*PAmm(i,j))+sum((i,j),PPAmncost*PPAmn(j))+
sum((i,j),PUrcost*PUr(i,j))+sum((i,j),PPUrcost*PPUr(j));

equation objective;
objective .. z =e= sum((i,j),Ammprice*x(i,j)) + sum((i,j),Urprice*y(i,j)) -
(cost1+cost2+cost3) ;

Model amm /all/;
Solve amm using lp maximizing z;
Display x.l, y.l, z.l, cost2.l, cost3.l, PAmm.l, PPAmn.l, PUr.l,PPUr.l ;

```



```

----      77 VARIABLE x.L  Ammonia sale product
           j1          j2          j3
i1      813.000      679.000      830.000

----      77 VARIABLE y.L  Urea sale product
           j1          j2          j3
i1      673.000      565.000      951.000

----      77 VARIABLE z.L                      = 191285.500 Profit
           VARIABLE cost2.L                   = 100520.500 logistic cost
           VARIABLE cost3.L                   = 21488.000 Penalty cost

----      77 VARIABLE PAmm.L  lack Ammonia
           ( ALL          0.000 )

----      77 VARIABLE PPAmm.L  Waste Ammonia
j3 16.000

----      77 VARIABLE PUr.L  lack Urea
           ( ALL          0.000 )

----      77 VARIABLE PPUr.L  Waste Urea
j3 287.000

```

Figure A GAMS programing of ammonia and urea plant with improved deterministic supply chain under fixed production rate.

## Appendix B

GAMS programing of ammonia and urea plant with improved deterministic supply chain under varied production rate

```

Sets
  i  plants / i1 /
  j  markets / j1, j2, j3 / ;

Parameters

  limam(j)  demand at market j in cases
            /  j1=813, j2=679, j3=814 /

  limur(j)  demand at market j in cases
            /  j1=673, j2=565, j3=664 / ;

Table d(i,j)  distance in miles
           j1      j2      j3
  i1      531      684      208  ;

Scalar f  freight in dollars per case per thousand miles /0.05/ ;
Scalar AmmOrigin  capacity of plant i in cases /3906/;
Scalar cost1      Ammonia production cost /635233/;
Scalar Ammprice   Ammonia sale price /206/;
Scalar PAmmcost   production cost /103/;
Scalar PPAmmcost  production cost /51.5/;
Scalar Urprice    Urea sale price /288/;
Scalar PUPrcost   production cost /144/;
Scalar PPUrcost   production cost /72/;

Parameter c(i,j)  transport cost in dollars per case ;

           c(i,j) = f * d(i,j)  ;

variables

  limcapam(i)  capacity of plant i in cases
  limcapur(i)  capacity of plant i in cases
  A2U(i)       Ammonia Feed to produce urea
  x(i,j)       Ammonia transported product (sale)
  y(i,j)       Urea transported product (sale)
  cost2        logistic cost
  cost3        Penalty cost
  cost4        Urea production cost
  PAmm(i,j)    lack Ammonia
  PPAmm(j)     Waste Ammonia
  PUr(i,j)     lack Urea
  PPUr(j)      Waste Urea
  z            Profit ;

```

```

positive variables limcapam, limcapur, A2U, x, y, PAmm, PPAm, PUr, PPUr;

equation con1(i) Ammonia Correlation;
con1(i).. limcapam(i)=e= AmmOrigin-A2U(i);

equation con2(i) Urea Correlation;
con2(i).. limcapur(i) =e= 1.4142*A2U(i)-0.014 ;

equation con3(i);
con3(i).. sum(j, x(i,j)) =e= limcapam(i);

equation con4(i);
con4(i).. sum(j, y(i,j)) =e= limcapur(i) ;

equation con5(j);
con5(j).. sum(i,x(i,j))+ sum(i,PAmm(i,j))-PPAm(j) =e= limam(j);

equation con6(j);
con6(j).. sum(i,y(i,j))+ sum(i,PUr(i,j))-PPUr(j) =e= limur(j);

equation con7 logistic cost;
con7 .. cost2 =e= sum((i,j),c(i,j)*(x(i,j)))+ sum((i,j),c(i,j)*(y(i,j)));

equation con8 Penalty cost;
con8 .. cost3 =e= sum((i,j),PAmmcost*PAmm(i,j))+sum((i,j),PPAmcost*PPAm(j))+
sum((i,j),PUrcost*PUr(i,j))+sum((i,j),PPUrcost*PPUr(j));

equation con9 Urea production cost;
con9 .. cost4 =e= sum((i),73.184*limcapur(i)-1.21);

equation objective;
objective .. z =e= sum((i,j),Ammprice*x(i,j)) + sum((i,j),Urprice*y(i,j)) -
(cost1+cost2+cost3+cost4) ;

Model amm /all/;
Solve amm using lp maximizing z;
Display limcapam.l, limcapur.l, x.l, y.l, z.l, cost2.l, cost3.l, cost4.l,
PAmm.l, PPAm.l, PUr.l, PPUr.l, A2U.l ;

```

```

----  S3 VARIABLE liscapam.L capacity of plant i in cases
i1 2306.000

----  S3 VARIABLE liscapur.L capacity of plant i in cases
i1 2262.706

----  S3 VARIABLE x.L Ammonia transported product (sale)
      j1      j2      j3
i1  813.000    879.000    814.000

----  S3 VARIABLE y.L Urea transported product (sale)
      j1      j2      j3
i1  673.000    565.000    1024.706

----  S3 VARIABLE z.L          = 198778.188 Profit
      VARIABLE cost2.L       = 101120.642 logistic cost
      VARIABLE cost3.L       = 35970.832 Penalty cost
      VARIABLE cost4.L       = 166892.664 Urea production cost

----  S3 VARIABLE FAm.L lack Ammonia
      ( ALL      0.000 )

----  S3 VARIABLE FPAmm.L Waste Ammonia
      ( ALL      0.000 )

----  S3 VARIABLE FUr.L lack Urea
      ( ALL      0.000 )

----  S3 VARIABLE FPUr.L Waste Urea
j3 360.706

----  S3 VARIABLE A2U.L Ammonia Feed to produce urea
i1 1600.000

```

**Figure B** GAMS programing ammonia and urea plant with improved deterministic supply chain under varied production rate.

# Appendix C

## Excel programing results of ammonia and urea plant with improved stochastic supply chain under fixed production rate (XY 1-6 of 30)

XY1	Ammonia						Urea						Penalty cost						Transportation Cost			Sale	Profit	
	Day	N	S	NE	N	S	NE	N	S	NE	N	S	NE	N	S	NE	Amm	Urea	Sum	Amm	Urea			Sum
1	677	762	851	687	581	634	0	0	1648	0	0	20664	1648	20664	22312	53218	47688	100906	1108764	190076	91966			
2	834	1262	801	478	632	558	16171	51500	4223	15048	7344	26136	71894	48528	120422	53218	47688	100906	1108764	91966	142786			
3	878	38	790	575	366	634	20703	37286	4790	8064	15480	20664	62779	44208	106987	53218	47688	100906	1108764	105401	165950			
4	777	700	773	614	513	692	10300	3193	5665	5256	4896	16488	19158	26640	45798	53218	47688	100906	1108764	166590	169579			
5	828	758	759	621	575	706	15553	206	6386	4752	432	15480	22145	20664	42809	53218	47688	100906	1108764	169579	142786			
6	987	637	784	712	494	695	31930	6438	5099	3600	6264	16272	43466	26136	69602	53218	47688	100906	1108764	142786	159411			
7	790	711	801	640	702	731	11639	2627	4223	3384	17424	13680	18489	34488	52977	53218	47688	100906	1108764	159411	135093			
8	911	675	748	623	475	511	24102	4481	6953	4608	7632	29520	35535	41760	77295	53218	47688	100906	1108764	135093	118226			
9	825	674	743	771	805	604	15244	4532	7210	12096	32256	22824	26986	67176	94162	53218	47688	100906	1108764	118226	133774			
10	888	829	895	723	737	628	21733	6901	1236	5184	22464	21096	29870	48744	78614	53218	47688	100906	1108764	133774	101890			
11	782	288	891	750	823	497	10815	24411	824	9072	34848	30528	36050	74448	110498	53218	47688	100906	1108764	101890	162873			
12	836	680	857	694	667	724	16377	4223	1339	1008	12384	14184	21939	27576	49515	53218	47688	100906	1108764	162873	121869			
13	770	956	822	798	693	564	14214	4893	12412	11448	1008	2736	31518	15192	46710	53218	47688	100906	1108764	121869	194000			
14	743	791	816	701	232	607	6798	2987	3451	2016	25128	22608	13236	49752	62988	53218	47688	100906	1108764	194000	165678			
15	815	667	642	528	588	940	14214	4893	12412	11448	1008	2736	31518	15192	46710	53218	47688	100906	1108764	165678	147708			
16	812	722	1040	779	643	777	13905	2060	16171	13248	8928	10368	32136	32544	64680	53218	47688	100906	1108764	147708	129355			
17	935	999	771	653	493	678	26574	24411	5768	2448	6336	17496	56753	26280	83033	53218	47688	100906	1108764	129355	155213			
18	776	439	766	676	644	719	10197	16635	6026	792	9072	14544	32857	24408	57265	53218	47688	100906	1108764	155213	115351			
19	997	375	743	701	648	570	32960	19931	7210	2016	9648	25272	60101	36936	97037	53218	47688	100906	1108764	115351	134267			
20	751	815	842	588	876	736	7622	5459	2112	7128	42480	13320	15193	62928	78121	53218	47688	100906	1108764	134267	148487			
21	932	625	868	679	486	610	26265	7056	773	576	6840	22392	34093	29808	63901	53218	47688	100906	1108764	148487	147322			
22	887	578	783	613	548	578	21630	9476	5150	5328	2376	24696	36256	32400	68656	53218	47688	100906	1108764	147322	154008			
23	864	633	904	731	633	692	19261	6644	2163	6336	7488	16488	28068	30312	58380	53218	47688	100906	1108764	154008	171914			
24	612	599	827	674	357	799	3348	8395	2884	936	16128	8784	14626	25848	40474	53218	47688	100906	1108764	171914	123981			
25	955	844	721	605	295	692	28634	8446	8343	5904	20592	16488	45423	42984	88407	53218	47688	100906	1108764	123981	125163			
26	913	509	908	766	355	634	24308	13030	2575	11376	16272	20664	39913	48312	88225	53218	47688	100906	1108764	125163	150675			
27	627	610	822	769	431	627	2575	7828	3142	11808	10800	21168	13545	43776	57321	53218	47688	100906	1108764	150675	135794			
28	726	677	686	830	303	693	5047	4378	10146	20592	20016	16416	19570	57024	76594	53218	47688	100906	1108764	135794	168865			
29	690	772	871	485	438	703	1339	1030	618	14544	10296	15696	2987	40536	43523	53218	47688	100906	1108764	168865	138701			
30	580	756	901	716	904	701	4996	309	1854	4176	46512	15840	7159	66528	73687	53218	47688	100906	1108764	138701	4261121			
Sum																								4261121

XY2	Ammonia						Urea						Penalty cost						Transportation Cost			Sale	Profit
	Day	N	S	NE	N	S	NE	N	S	NE	N	S	NE	N	S	NE	Amm	Urea	Sum	Amm	Urea		
1	677	762	851	687	581	634	8086	7725	5150	30096	3672	32040	20961	65808	86769	53969	45527	99495	1108764	127300	91966		
2	834	1262	801	478	632	558	0	59225	0	0	0	0	37512	59225	37512	96737	53969	45527	99495	1108764	117062	110117	
3	878	38	790	575	366	634	4532	33424	567	13968	19152	32040	38522	65160	103682	53969	45527	99495	1108764	110117	152066		
4	777	700	773	614	513	692	2936	1339	1442	19584	8568	27864	5717	56016	61733	53969	45527	99495	1108764	152066	152462		
5	828	758	759	621	575	706	309	7313	2163	20592	4104	26856	9785	11552	61337	53969	45527	99495	1108764	152462	123300		
6	987	637	784	712	494	695	15759	2575	876	33696	9936	27648	19210	71280	90490	53969	45527	99495	1108764	123300	150597		
7	790	711	801	640	702	731	2266	2472	0	23328	10080	25056	4738	58464	63202	53969	45527	99495	1108764	150597	129440		
8	911	675	748	623	475	511	7931	618	2730	20880	11304	40896	11279	73080	84359	53969	45527	99495	1108764	129440	108375		
9	825	674	743	771	805	604	464	670	2987	42192	24912	34200	4120	101304	105424	53969	45527	99495	1108764	108375	101057		
10	888	829	895	723	737	628	5562	14626	9682	35280	15120	32472	29870	82872	112742	53969	45527	99495	1108764	101057	72726		
11	782	288	891	750	823	497	2678	20549	9270	39168	27504	41904	32497	108576	141073	53969	45527	99495	1108764	72726	145760		
12	836	680	857	694	667	724	206	361	5768	31104	5040	25560	6335	61704	68039	53969	45527	99495	1108764	145760	88689		
13	770	956	822	798	693	564	3296	27707	2163	46080	8784	37080	33166	91944	125110	53969	45527	99495	1108764	88689	101959		
14	743	791	816	701	232	607	4687	10712	1545	32112	28800	33984	16944	94896	111840	53969	45527	99495	1108764	101959	183226		
15	815	667	642	528	588	940	979	1030	8189	2010	3168	10008	10197	20376	30573	53969	45527	99495	1108764	183226	117772		
16	812	722	1040	779	643	777	1133	3605	24617	43344	1584	21744	29355	66672	96027	53969	45527	99495	1108764	117772	105635		
17	935	999	771	653	493	678	10403	32136	1545	25200	10008	28872	44084	108164	53969	45527	99495	1108764	105635	140077			
18	776	439	766	676	644	719	2987	12772	1803	28512	1728	25920	17562	56160	73722	53969	45527	99495	1108764	140077	106891		
19	997	375	743	701	648	570	16789	16068	2987	32112	2304	36648	35844	71064	106908	53969	45527	99495	1108764	106891	116445		
20	751	815	842	588	876	736	4275	13184	4223	15840	35136	24696	21682	75672	97354	53969	45527	99495	1108764	116445	120387		
21	932	625	868	679	486	610	10094	3193	6901	28944	10512	33768	20188	73224	94314	53969	45527	99495	1108764	120387	140239		
22	887	578	783	613	548	578	5459	5614	927	19440	6048	36072	12000	61560	73560	53969	45527	99495	1108764	140239	132879		
23	864	633	904	731	633	692	3090	2781	10609	36432	144	27864	16480	64440	80920	53969	45527	99495	1108764	132879	126972		
24	612	599	827	674	357	799	11433	4532	2678	28224	19800	20160	18643	68184	86827	53969	45527	99495	1108764	126972	110629		
25	955	844	721	605	295	692	12463	16171	4120	18288	24264	27864	32754	70416	103170	53969	45527	99495	1108764	110629	92018		
26	913	509	908	766	355	634	8137	9167	11021	41472	19944	32											

XY4	Ammonia			Urea			Penalty cost						Transportation Cost			Sale	Profit				
	N	S	NE	N	S	NE	N	S	NE	N	S	NE	Amm	Urea	Sum			Amm	Urea	Sum	
1	677	762	851	687	581	634	5150	6386	618	10512	9792	30816	12154	51120	63274	53357	44891	98248	1108764	151772	
2	834	1262	801	478	632	558	5871	57886	2266	9792	17136	36288	66023	63216	129239	53357	44891	98248	1108764	85807	
3	878	38	790	575	366	634	10403	34093	2833	2808	10584	30816	47329	44208	91537	53357	44891	98248	1108764	123509	
4	777	700	773	614	513	692	0	0	3708	0	0	26640	3708	26640	30348	53357	44891	98248	1108764	184698	
5	828	758	759	621	575	706	5253	5974	4429	1008	8928	25632	15656	35568	51224	53357	44891	98248	1108764	163822	
6	987	637	784	712	494	695	21630	3245	3142	14112	1368	26424	28016	41904	69920	53357	44891	98248	1108764	145126	
7	790	711	801	640	702	731	1339	1133	2266	3744	27216	23832	4738	54792	59530	53357	44891	98248	1108764	155516	
8	911	675	748	623	475	511	13802	1288	4996	1296	2736	39672	20085	43704	63789	53357	44891	98248	1108764	151257	
9	825	674	743	771	805	604	4944	1339	5253	22608	42048	32976	11536	97632	109168	53357	44891	98248	1108764	105878	
10	888	829	895	723	737	628	11433	13287	5150	15696	32256	31248	29870	79200	109070	53357	44891	98248	1108764	105976	
11	782	288	891	750	823	497	515	21218	4738	19584	44640	40680	26471	104904	131375	53357	44891	98248	1108764	83671	
12	836	680	857	694	667	724	6077	1030	1236	11520	22176	24336	8343	58032	66375	53357	44891	98248	1108764	148671	
13	770	956	822	798	693	564	361	26368	1185	26496	25920	35856	27913	88272	116185	53357	44891	98248	1108764	98861	
14	743	791	816	701	232	607	1751	9373	1494	12528	20232	32760	12618	65520	78138	53357	44891	98248	1108764	136908	
15	815	667	642	528	588	940	3914	1700	10455	6192	10800	8784	16068	25776	41844	53357	44891	98248	1108764	173202	
16	812	722	1040	779	643	777	3605	2266	20085	23760	18720	20520	25956	63000	88956	53357	44891	98248	1108764	126090	
17	935	999	771	653	493	678	16274	30797	3811	5616	1440	27648	50882	34704	85586	53357	44891	98248	1108764	129460	
18	776	439	766	676	644	719	52	13442	4069	8928	18864	24696	17562	52488	70050	53357	44891	98248	1108764	144996	
19	997	375	743	701	648	570	22660	16738	5253	12528	19440	35424	44651	67392	112043	53357	44891	98248	1108764	103003	
20	751	815	842	588	876	736	1339	11845	155	1872	23472	13339	77616	90955	53357	44891	98248	1108764	124091		
21	932	625	868	679	486	610	15965	3863	2369	9360	1944	32544	22197	43848	66045	53357	44891	98248	1108764	149001	
22	887	578	783	613	548	578	11330	6283	3193	72	5040	34848	20806	39960	60766	53357	44891	98248	1108764	154280	
23	864	633	904	731	633	692	8961	3451	6077	18648	17280	26640	18489	60768	79257	53357	44891	98248	1108764	135789	
24	612	599	827	674	357	799	8498	5202	927	8640	11232	18936	14626	38808	53434	53357	44891	98248	1108764	161612	
25	955	844	721	605	295	692	18334	14832	6386	648	15696	26640	39552	42984	82536	53357	44891	98248	1108764	132510	
26	913	509	908	766	355	634	14008	9837	6489	21888	11376	30816	30334	64080	94414	53357	44891	98248	1108764	120632	
27	627	610	822	769	431	627	7725	4635	1185	23200	5904	31320	13545	59544	73089	53357	44891	98248	1108764	141957	
28	726	677	686	830	303	693	2627	1185	8189	31104	15120	26568	12000	72792	84792	53357	44891	98248	1108764	130254	
29	690	772	871	485	438	703	4481	7416	2678	9288	5400	25848	14575	40536	55111	53357	44891	98248	1108764	159935	
30	580	756	901	716	904	701	10146	5768	5768	14688	56304	25992	21682	96984	118666	53357	44891	98248	1108764	96380	
Sum																					4024657

XY5	Ammonia			Urea			Penalty cost						Transportation Cost			Sale	Profit			
	N	S	NE	N	S	NE	N	S	NE	N	S	NE	Amm	Urea	Sum			Amm	Urea	Sum
1	677	762	851	687	581	634	7777	2781	9476	9504	864	25848	20034	36216	56250	55014	46480	101494	1108764	155551
2	834	1262	801	478	632	558	618	54281	4326	10296	8208	31320	59225	49824	109049	55014	46480	101494	1108764	102751
3	878	38	790	575	366	634	5150	35896	3193	3312	15048	25848	44239	44208	88447	55014	46480	101494	1108764	123354
4	777	700	773	614	513	692	2627	1803	1442	504	4464	21672	5871	26640	32511	55014	46480	101494	1108764	179289
5	828	758	759	621	575	706	0	2369	0	0	0	20664	2369	20664	23033	55014	46480	101494	1108764	188767
6	987	637	784	712	494	695	16377	5047	2575	13104	5832	23999	40392	64391	55014	46480	101494	1108764	147409	
7	790	711	801	640	702	731	1957	1236	4326	2756	18288	18864	7519	39888	47407	55014	46480	101494	1108764	164393
8	911	675	748	623	475	511	8549	3090	567	288	7200	34704	12206	42192	54398	55014	46480	101494	1108764	157403
9	825	674	743	771	805	604	155	3142	824	21600	33120	28008	4120	82728	86848	55014	46480	101494	1108764	124952
10	888	829	895	723	737	628	6180	9682	14008	14688	23328	29870	64296	94166	55014	46480	101494	1108764	117634	
11	782	288	891	750	823	497	2369	23021	13596	18756	35712	35712	38986	90000	128986	55014	46480	101494	1108764	82815
12	836	680	857	694	667	724	824	2833	10094	10512	13248	19368	13751	43128	56879	55014	46480	101494	1108764	154922
13	770	956	822	798	693	564	2987	22763	6489	25488	16992	30888	32239	73368	105607	55014	46480	101494	1108764	106193
14	743	791	816	701	232	607	4378	5768	5871	11520	24696	27792	16017	64008	80025	55014	46480	101494	1108764	131776
15	815	667	642	528	588	940	670	3502	6026	6696	1872	3816	10197	12384	22581	55014	46480	101494	1108764	189219
16	812	722	1040	779	643	777	824	670	28943	22752	9792	15552	30437	48096	78533	55014	46480	101494	1108764	133268
17	935	999	771	653	493	678	11021	27192	1236	4608	5904	22680	39449	33192	72641	55014	46480	101494	1108764	139159
18	776	439	766	676	644	719	2678	15244	721	7920	9936	19728	18643	37584	56227	55014	46480	101494	1108764	155373
19	997	375	743	701	648	570	17407	18540	824	11120	10512	30456	36771	52488	89259	55014	46480	101494	1108764	122541
20	751	815	842	588	876	736	3966	8240	8549	2376	43344	18504	20755	64224	84979	55014	46480	101494	1108764	126822
21	932	625	868	679	486	610	10712	5665	11227	8352	6408	27576	27604	42336	69940	55014	46480	101494	1108764	141860
22	887	578	783	613	548	578	6077	8086	2472	576	1944	29880	16635	32400	49035	55014	46480	101494	1108764	162766
23	864	633	904	731	633	692	11124	7004	7004	7632	15696	13968	25132	37296	62428	55014	46480	101494	1108764	149372
24	612	599	827	674	357	799	11124	7004	7004	7632	15696	13968	25132	37296	62428	55014	46480	101494	1108764	149372
25	955	844	721	605	295	692	13081	11227	1957	1152	20160	21672	26265	42984	69249	55014	46480	101494	1108764	142551
26	913	509	908	766	355	634	8755	11639	15347	20880	15840	25848	35741	62568	98309	55014	46480	101494	1108764	131491
27	627	610	822	769	431	627	10352	6438	6489	21312	10368	26352	23278	58032	81310	55014	46480	101494	1108764	130490
28	726	677	686	830	303	693	5253	2987	3760	30096	19584	21600	12000	71280	83280	55014	46480	101494	1108764	128521
29	690	772	871	485	438	703	7107	3811	11536	9792	9864	20880	22454	40536	62990	55014	46480	101494	1108764	148810
30	580	756	901	716	904	701	12772	2163	14626	13680	47376	21024	29561	82080	111641	55014	4			



# Appendix D

## Excel programing results of ammonia and urea plant with improved stochastic supply chain under varied production rate (XY 1-6 of 30)

Day	Ammonia			Urea			Penalty cost						Transportation Cost			Urea cost	Sale	Profit			
	N	S	NE	N	S	NE	N	S	NE	Urea	Amm	Urea	Sum	Urea	Amm				Urea		
1	677	762	851	687	581	634	0	0	0	0	27600	0	27600	27600	52885	48690	101575	167249	1129916	198259	
2	834	1262	801	478	632	558	16171	51500	2575	15048	7344	33072	70246	55464	125710	52885	48690	101575	167249	1129916	100149
3	878	38	790	575	366	634	20703	37286	3142	8064	15480	27600	61131	51144	112274	52885	48690	101575	167249	1129916	113584
4	777	700	773	614	513	692	10300	3193	4017	5256	4896	23424	17510	33576	51086	52885	48690	101575	167249	1129916	174773
5	828	758	759	621	575	706	15553	206	4738	4752	432	22416	20497	27600	48097	52885	48690	101575	167249	1129916	177762
6	987	637	784	712	494	695	31930	6438	3451	3600	6264	23208	41818	33072	74890	52885	48690	101575	167249	1129916	150969
7	790	711	801	640	702	731	11639	2627	2575	3384	17424	20616	16841	41424	58264	52885	48690	101575	167249	1129916	167594
8	911	675	748	623	475	511	24102	4481	5305	4608	7632	36456	38887	48696	82583	52885	48690	101575	167249	1129916	143276
9	825	674	743	771	805	604	15244	4532	5562	12096	32256	29760	25338	74112	99450	52885	48690	101575	167249	1129916	126409
10	888	829	895	723	737	628	21733	6901	4532	5184	24644	28032	33166	55680	88846	52885	48690	101575	167249	1129916	137013
11	782	288	891	750	823	497	10815	24411	4120	9072	34848	37464	39346	81384	120730	52885	48690	101575	167249	1129916	105129
12	836	680	857	694	667	724	16377	4223	618	1008	12384	21120	21218	34512	55730	52885	48690	101575	167249	1129916	170129
13	770	956	822	798	693	564	9579	19982	1494	15984	16128	32640	31055	64752	95806	52885	48690	101575	167249	1129916	130052
14	743	791	816	701	232	607	6798	2987	1803	2016	25128	29544	11588	56688	68275	52885	48690	101575	167249	1129916	157583
15	815	667	642	528	588	940	14214	4893	10764	11448	1008	5568	29870	18024	47894	52885	48690	101575	167249	1129916	177965
16	812	722	1040	779	643	777	13905	2060	19467	13248	8928	17304	35432	39480	74912	52885	48690	101575	167249	1129916	150947
17	935	999	771	653	493	678	26574	24411	4120	2448	6336	24432	55105	33216	88321	52885	48690	101575	167249	1129916	137538
18	776	439	766	676	644	719	10197	16635	4378	742	9072	21480	31209	31344	62553	52885	48690	101575	167249	1129916	163606
19	997	375	743	701	648	570	32960	19931	5562	2016	9648	32208	58453	43872	102324	52885	48690	101575	167249	1129916	123534
20	751	815	842	588	876	736	7622	5459	464	7128	42480	20256	13545	69864	83408	52885	48690	101575	167249	1129916	142450
21	932	625	868	679	486	610	26265	7056	1751	576	6840	29328	35072	36744	71815	52885	48690	101575	167249	1129916	154043
22	887	578	783	613	548	578	21630	9476	3502	5328	2376	31632	34608	39336	73944	52885	48690	101575	167249	1129916	151915
23	864	633	904	731	633	692	19261	6644	5459	6336	7488	23424	31364	37248	68611	52885	48690	101575	167249	1129916	157247
24	612	599	827	674	357	799	3348	8395	1236	936	16128	15720	12978	32784	45762	52885	48690	101575	167249	1129916	180097
25	955	844	721	605	295	692	28634	8446	6695	5904	20592	23424	43775	49920	93695	52885	48690	101575	167249	1129916	132164
26	913	509	908	766	355	634	24308	13040	5871	11308	16720	27600	43209	55248	98456	52885	48690	101575	167249	1129916	127402
27	627	610	822	769	431	627	2575	7828	1494	11808	10800	28104	11897	50712	62608	52885	48690	101575	167249	1129916	163250
28	726	677	686	830	303	693	5047	4378	8498	20592	20016	23352	17922	63960	81882	52885	48690	101575	167249	1129916	143977
29	690	772	871	485	438	703	1339	1030	2060	14544	10296	22632	4429	47472	51901	52885	48690	101575	167249	1129916	173958
30	580	756	901	716	904	701	4996	309	5150	4176	46512	22776	10455	73464	83918	52885	48690	101575	167249	1129916	141940
Sum																					4474415

Day	Ammonia			Urea			Penalty cost						Transportation Cost			Urea cost	Sale	Profit			
	N	S	NE	N	S	NE	N	S	NE	Amm	Urea	Sum	Urea	Amm	Urea						
1	677	762	851	687	581	634	8086	16971	5150	30096	3672	10944	30206	44712	74918	67803	40109	107912	122070	1042048	101916
2	834	1262	801	478	632	558	0	17559	0	0	0	17559	0	17559	67803	40109	107912	122070	1042048	101916	159275
3	878	38	790	575	366	634	4532	54257	567	13968	19152	10944	59355	44064	103419	67803	40109	107912	122070	1042048	73415
4	777	700	773	614	513	692	2936	20164	1442	19584	8568	19296	24541	47448	71989	67803	40109	107912	122070	1042048	104845
5	828	758	759	621	575	706	309	17177	2163	20592	4104	21312	19649	46008	65657	67803	40109	107912	122070	1042048	111177
6	987	637	784	712	494	695	15759	23408	876	33696	9936	19728	40043	63360	103403	67803	40109	107912	122070	1042048	73431
7	790	711	801	640	702	731	2266	19597	0	23238	10080	24912	21863	58320	80183	67803	40109	107912	122070	1042048	96651
8	911	675	748	623	475	511	7931	21451	2730	20880	11304	3384	32112	35568	67680	67803	40109	107912	122070	1042048	109154
9	825	674	743	771	805	604	464	21503	2987	42192	24912	6624	24953	73728	98681	67803	40109	107912	122070	1042048	78153
10	888	829	895	723	737	628	5562	13520	9682	35280	15120	10080	28764	60480	89244	67803	40109	107912	122070	1042048	87590
11	782	288	891	750	823	497	2678	41382	9270	39168	27504	4392	53300	71064	124394	67803	40109	107912	122070	1042048	52440
12	836	680	857	694	667	724	206	21194	5768	31104	5040	23904	27168	60048	87216	67803	40109	107912	122070	1042048	89618
13	770	956	822	798	693	564	3296	6980	2163	46080	8784	864	12439	55728	68167	67803	40109	107912	122070	1042048	108667
14	743	791	816	701	232	607	4687	15477	1545	32112	28800	7056	21709	67968	89677	67803	40109	107912	122070	1042048	87157
15	815	667	642	528	588	940	979	21863	8189	7200	3168	55008	31030	65376	96406	67803	40109	107912	122070	1042048	80428
16	812	722	1040	779	643	777	1133	19031	24617	43344	1584	31536	44781	74644	121245	67803	40109	107912	122070	1042048	55589
17	935	999	771	653	493	678	10403	4765	1545	25200	10008	17280	16713	52488	69201	67803	40109	107912	122070	1042048	107633
18	776	439	766	676	644	719	2987	33605	1803	28512	1728	23184	38395	53424	91819	67803	40109	107912	122070	1042048	85015
19	997	375	743	701	648	570	16789	36901	2987	32112	2304	1728	56677	36144	92821	67803	40109	107912	122070	1042048	84013
20	751	815	842	588	876	736	4275	14241	4223	15840	35136	25632	22739	76608	99347	67803	40109	107912	122070	1042048	77487
21	932	625	868	679	486	610	10094	24026	6901	28944	10512	7488	41021	46944	87965	67803	40109	107912	122070	1042048	88869
22	887	578	783	613	548	578	5459	26447	927	19440	6048	2880	32833	28368	61201	67803	40109	107912	122070	1042048	115633
23	864	633	904	731	633	692	3090	23654	10699	36432	144	19296	37213	55872	93195	67803	40109	107912	122070	1042048	83649
24	612	599	827	674	357	799	11433	25365	2678	28224	19800	34704	39476	82726	122024	67803	40109	107912	122070	1042048	54630
25	955	844	721	605	295	692	12463	12748	4120	18288	24264	19296	29331	61848	91179	67803	40109	107912	122070	1042048	85655
26	913	509	908	766																	

Day	Ammonia			Urea			Penalty cost						Transportation Cost			Urea		Sale	Profit			
	N	S	NE	N	S	NE	N	S	NE	N	S	NE	Amm	Urea	Sum	Amm	Urea			Sum	cost	Sale
1	677	762	851	687	581	634	5150	6386	8034	10512	9792	41825	19570	62129	81699	52609	46481	99090	171388	1137967	150557	
2	834	1262	801	478	632	558	5871	57886	2884	9792	17136	47297	66641	74225	140866	52609	46481	99090	171388	1137967	91390	
3	878	38	790	575	366	634	10403	34093	1751	2808	10584	41825	46247	55217	101464	52609	46481	99090	171388	1137967	130792	
4	777	700	773	614	513	692	0	0	0	0	0	37649	0	37649	37649	52609	46481	99090	171388	1137967	194607	
5	828	758	759	621	575	706	5253	5974	721	1008	8928	36641	11948	46577	58525	52609	46481	99090	171388	1137967	173731	
6	987	637	784	712	494	695	21630	3245	1133	14112	1368	37433	26008	52913	78920	52609	46481	99090	171388	1137967	153336	
7	790	711	801	640	702	731	1339	1133	2884	3744	27216	34841	5356	65801	71157	52609	46481	99090	171388	1137967	161099	
8	911	675	748	623	475	511	13802	1288	1288	1296	2736	50681	16377	54713	71090	52609	46481	99090	171388	1137967	161166	
9	825	674	743	771	805	604	4944	1339	1545	22608	42048	43985	7828	108641	116469	52609	46481	99090	171388	1137967	115787	
10	888	829	895	723	737	628	11433	13287	12566	15696	32256	52257	37286	90209	127495	52609	46481	99090	171388	1137967	104761	
11	782	288	891	750	823	497	515	21218	12154	19584	46460	51689	33887	115913	149800	52609	46481	99090	171388	1137967	82456	
12	836	680	857	694	667	724	6077	1030	8652	11520	22176	35345	15759	69041	84800	52609	46481	99090	171388	1137967	147456	
13	770	956	822	798	693	564	361	26368	5047	26496	25920	46865	31776	99281	131056	52609	46481	99090	171388	1137967	101200	
14	743	791	816	701	232	607	1751	9373	4429	12528	20232	43769	15553	76529	92082	52609	46481	99090	171388	1137967	140174	
15	815	667	642	528	588	940	3914	1700	6747	6192	10800	19793	12360	36785	49145	52609	46481	99090	171388	1137967	183111	
16	812	722	1040	779	643	777	3605	2266	27501	23760	18720	33372	74009	107381	52609	46481	99090	171388	1137967	124875		
17	935	999	771	653	493	678	16274	30797	103	5616	1440	36557	47174	45713	92887	52609	46481	99090	171388	1137967	193869	
18	776	439	766	676	644	719	52	13442	361	8928	18864	35705	13654	63497	77350	52609	46481	99090	171388	1137967	154906	
19	997	375	743	701	648	570	22660	16738	1545	12528	19440	46433	40943	78401	119343	52609	46481	99090	171388	1137967	112913	
20	751	815	842	588	876	736	1339	11845	7107	1872	52772	34481	20291	88625	108916	52609	46481	99090	171388	1137967	123340	
21	932	625	868	679	486	610	15965	3863	9785	9360	1944	43553	29613	54857	84469	52609	46481	99090	171388	1137967	147787	
22	887	578	783	613	548	578	11330	6283	1030	72	5040	45857	18643	50969	69612	52609	46481	99090	171388	1137967	162644	
23	864	633	904	731	633	692	8961	3451	13493	16848	17280	37649	25905	71777	97681	52609	46481	99090	171388	1137967	134575	
24	612	599	827	674	357	799	8498	5202	5562	8640	11232	29945	19261	49817	69078	52609	46481	99090	171388	1137967	163178	
25	955	844	721	605	295	692	18334	14832	2678	648	15696	37649	35844	53993	89837	52609	46481	99090	171388	1137967	142419	
26	913	509	908	766	355	634	14008	9837	13905	21888	11376	41825	37750	75089	112838	52609	46481	99090	171388	1137967	119418	
27	627	610	822	769	431	627	7725	4635	5047	22320	5904	42329	17407	70553	87960	52609	46481	99090	171388	1137967	144296	
28	726	677	686	830	303	693	2627	1185	4481	31104	15120	37577	8292	83801	92092	52609	46481	99090	171388	1137967	140164	
29	690	772	871	485	438	703	4481	7416	10094	9288	5400	36857	21991	51545	73535	52609	46481	99090	171388	1137967	158721	
30	580	756	901	716	904	701	10146	5768	13184	14688	56304	37001	29098	107993	137090	52609	46481	99090	171388	1137967	95166	
Sum																						4155399

Day	Ammonia			Urea			Penalty cost						Transportation Cost			Urea		Sale	Profit		
	N	S	NE	N	S	NE	N	S	NE	N	S	NE	Amm	Urea	Sum	Amm	Urea			Sum	cost
1	677	762	851	687	581	634	7777	412	9476	9504	864	27184	17665	37552	55216	55801	46673	102473	161556	118845	164366
2	834	1262	801	478	632	558	618	51912	4326	10296	8208	32656	56856	51160	108016	55801	46673	102473	161556	118845	111567
3	878	38	790	575	366	634	5150	37080	3193	3312	15048	27184	45423	45544	90967	55801	46673	102473	161556	118845	128616
4	777	700	773	614	513	692	2627	2987	1442	504	4464	23008	7056	27976	35031	55801	46673	102473	161556	118845	184551
5	828	758	759	621	575	706	0	0	0	0	0	22000	0	22000	22000	55801	46673	102473	161556	118845	197583
6	987	637	784	712	494	695	16377	6232	2575	13104	5832	22792	25184	41728	66911	55801	46673	102473	161556	118845	152671
7	790	711	801	640	702	731	1957	2421	4326	2736	18288	20200	8704	41224	49927	55801	46673	102473	161556	118845	169655
8	911	675	748	623	475	511	8549	4275	567	288	7200	36040	13390	43528	56918	55801	46673	102473	161556	118845	162665
9	825	674	743	771	805	604	155	4316	824	21600	33120	29344	5305	84064	89368	55801	46673	102473	161556	118845	130214
10	888	829	895	723	737	628	6180	7313	14008	14698	23328	27616	27501	65532	93133	55801	46673	102473	161556	118845	126450
11	782	288	891	750	823	497	2369	24205	13596	18576	35712	37048	40170	91336	131506	55801	46673	102473	161556	118845	80077
12	836	680	857	694	667	724	824	4047	10094	10512	13248	20704	14935	44664	59399	55801	46673	102473	161556	118845	160184
13	770	956	822	798	693	564	2987	20394	6489	25488	16992	32224	29870	74704	104574	55801	46673	102473	161556	118845	115009
14	743	791	816	701	232	607	4378	3399	5871	11520	24696	29128	13648	65344	78991	55801	46673	102473	161556	118845	140591
15	815	667	642	528	588	940	670	4687	6026	6696	1872	5152	11382	13720	25101	55801	46673	102473	161556	118845	194481
16	812	722	1040	779	643	777	824	1854	28943	22752	9792	16888	31621	49432	81053	55801	46673	102473	161556	118845	138530
17	935	999	771	653	493	678	11021	24823	1236	4608	5904	24016	37080	34528	71608	55801	46673	102473	161556	118845	147975
18	776	439	766	676	644	719	2678	16429	721	7920	9936	21064	19828	38920	58747	55801	46673	102473	161556	118845	160835
19	997	375	743	701	648	570	17407	19725	824	11520	10512	31792	37956	53824	91779	55801	46673	102473	161556	118845	127803
20	751	815	842	588	876	736	3966	5871	8549	2376	43344	19840	18386	65560	83945	55801	46673	102473	161556	118845	135637
21	932	625	868	679	486	610	10712	6850	11227	8352	6408	28912	28789	43672	72460	55801	46673	102473	161556	118845	147122
22	887	578	783	613	548	578	6077	9270	2472	576	1944	31216	17819	33736	51555	55801	46673	102473	161556	118845	168028
23	864	633	904	731	633	692	3708	6438	14935	15840	8352	23008	25081	47200	72280	55801	46673	102473	161556	118845	147302
24	612	599	827	674	357	799	11124	8189	7004	7632	15696	15304	26317	38632	64948	55801	46673	102473	161556	118845	154634
25	955	844	721	605	295	692	13081	8858	1957	1152	20160	23008	23896	44320	68216	55801	46673	102473	161556	118845	151367
26	913	509	908	766	355	634	8755	12824	15347	10880	15840	27184	36926	63904	100829	55801	46673				



## REFERENCES

- Akbari, M., Oyedun, A.O., and Kumar, A. (2018). Ammonia production from black liquor gasification and co-gasification with pulp and waste sludges: A techno-economic assessment. Energy, 151, 133-143.
- Azzaro-Pantel, C. (2018). Hydrogen Supply Chain: Design, Deployment and Operation: Academic Press.
- Barkhordarian, O., Behbahaninia, A., and Bahrampoury, R. (2017). A novel ammonia-water combined power and refrigeration cycle with two different cooling temperature levels. Energy, 120, 816-826.
- Bicer, Y., Dincer, I., Zamfirescu, C., Vezina, G., and Raso, F. (2016). Comparative life cycle assessment of various ammonia production methods. Journal of Cleaner Production, 135, 1379-1395.
- Cetinkaya, E., Dincer, I., and Naterer, G.F. (2012). Life cycle assessment of various hydrogen production methods. International Journal of Hydrogen Energy, 37(3), 2071-2080.
- Chakraborty, D., Petersen, H.N., Elkjær, C., Cagulada, A., and Johannessen, T.J.F.C.B. (2009). Solid ammonia as energy carrier: Current status and future prospects. 2009(10), 12-15.
- Cheah, K.W., Yusup, S., Gurdeep Singh, H.K., Uemura, Y., and Lam, H.L. (2017). Process simulation and techno economic analysis of renewable diesel production via catalytic decarboxylation of rubber seed oil - A case study in Malaysia. J Environ Manage, 203(Pt 3), 950-961.
- Chen, J., Huang, M., Cao, F., Pardha-Saradhi, P., and Zou, Y. (2017). Urea application promotes amino acid metabolism and membrane lipid peroxidation in *Azolla*. PLoS One, 12(9), 85-90.
- Chisholm, H.J.C., UK: Cambridge University Press. (1911). Ammonia. Encyclopedia Britannica (Vol. 1).
- Chowdhury, M.R.I., Sarwar, A., and Farooque, A.J.A.J.P.S. (2002). Effect of different methods of urea application on growth and yield in potato. 1, 672-674.
- Copplestone, J., and Kirk, C.J.R.D. (2008). Ammonia and urea production. 12, 2011.
- dos Santos, P.C., and Szklo, A.S. (2016). Urea imports in Brazil: The increasing

- demand pressure from the biofuels industry and the role of domestic natural gas for the country's urea production growth. Journal of Natural Gas Science and Engineering, 29, 188-200.
- Edrisi, A., Mansoori, Z., and Dabir, B. (2016). Urea synthesis using chemical looping process – Techno-economic evaluation of a novel plant configuration for a green production. International Journal of Greenhouse Gas Control, 44, 42-51.
- Frattini, D., Cinti, G., Bidini, G., Desideri, U., Cioffi, R., and Jannelli, E. (2016). A system approach in energy evaluation of different renewable energies sources integration in ammonia production plants. Renewable Energy, 99, 472-482.
- Gilbert, P., Alexander, S., Thornley, P., and Brammer, J. (2014). Assessing economically viable carbon reductions for the production of ammonia from biomass gasification. Journal of Cleaner Production, 64, 581-589.
- Giuffrida, A., Romano, M.C., and Lozza, G.G. (2010). Thermodynamic assessment of IGCC power plants with hot fuel gas desulfurization. Applied Energy, 87(11), 3374-3383.
- Glibert, P.M., Harrison, J., Heil, C., and Seitzinger, S. (2006). Escalating Worldwide use of Urea – A Global Change Contributing to Coastal Eutrophication. Biogeochemistry, 77(3), 441-463.
- Han, Z., Sachdeva, S., Papadaki, M., and Mannan, M.S. (2015). Calorimetry studies of ammonium nitrate – Effect of inhibitors, confinement, and heating rate. Journal of Loss Prevention in the Process Industries, 38, 234-242.
- Lin, K.-W., and Wu, H.-W. (2020). Hydrogen-rich syngas production and carbon dioxide formation using aqueous urea solution in biogas steam reforming by thermodynamic analysis. International Journal of Hydrogen Energy, 45(20), 11593-11604.
- Meessen, J.H., and Petersen, H. (2000). Urea. Ullmann's Encyclopedia of Industrial Chemistry.
- Modak, J.M.J.R. (2002). Haber process for ammonia synthesis. 7(9), 69-77.
- Ochoa-Fernández, E., Rusten, H.K., Jakobsen, H.A., Rønning, M., Holmen, A., and Chen, D. (2005). Sorption enhanced hydrogen production by steam methane reforming using Li<sub>2</sub>ZrO<sub>3</sub> as sorbent: Sorption kinetics and reactor simulation.

Catalysis Today, 106(1), 41-46.

- Pishvae, M.S., Jolai, F., and Razmi, J. (2009). A stochastic optimization model for integrated forward/reverse logistics network design. Journal of Manufacturing Systems, 28(4), 107-114.
- Sakuragi, K., Igarashi, K., and Samejima, M. (2018). Application of ammonia pretreatment to enable enzymatic hydrolysis of hardwood biomass. Polymer Degradation and Stability, 148, 19-25.
- Santipanusopon, S., and Riyajan, S.-A.J.P.P. (2009). Effect of field natural rubber latex with different ammonia contents and storage period on physical properties of latex concentrate, stability of skim latex and dipped film. 2(1), 127-134.
- Seider, W., Seader, J., Lewin, D., Widagdo, S.J.P., Process Design Principles: Synthesis, A., and Design. (2004). Cost accounting and capital cost estimation. 472-562.
- Seifi, S., Diatta-Dieme, M.T., Blanchart, P., Lecomte-Nana, G.L., Kobor, D., and Petit, S. (2016). Kaolin intercalated by urea. Ceramic applications. Construction and Building Materials, 113, 579-585.
- Valera-Medina, A., Xiao, H., Owen-Jones, M., David, W.I.F., and Bowen, P.J. (2018). Ammonia for power. Progress in Energy and Combustion Science, 69, 63-102.
- Xiang, D., and Zhou, Y. (2018). Concept design and techno-economic performance of hydrogen and ammonia co-generation by coke-oven gas-pressure swing adsorption integrated with chemical looping hydrogen process. Applied Energy, 229, 1024-1034.
- Yapicioglu, A., and Dincer, I. (2019). A review on clean ammonia as a potential fuel for power generators. Renewable and Sustainable Energy Reviews, 103, 96-108.
- Intelligence, M.. Ammonia market. 17 May 2018. 18 Sep 2019. <<https://www.mordorintelligence.com/industry-reports/ammonia-market>>
- Venkat Pattabathula, J.R.. "Introduction to Ammonia Production." 16 June 2017. 18 Sep 2019 <<https://www.aiche.org/resources/publications/cep/2016/september/introduction-ammonia-production>>

**VITA**

<b>NAME</b>	Seangplang Srisamut
<b>DATE OF BIRTH</b>	18 July 1994
<b>PLACE OF BIRTH</b>	Songkhla, Thailand
<b>HOME ADDRESS</b>	62/49, Khao Rup Chang, Mueang Songkhla District, Songkhla, Thailand



2619937106

CU IThesis 6173002063 thesis / recv: 20072563 10:48:08 / seq: 18