

Chapter 3

Materials and Methods

3.1 Experimental setup

A. Fluidized Bed Airlift Filter (Fig3.1)

The airlift column is made of transparent acrylic plastic. The wall thickness of the outer column is 5 mm whereas the inner column is 3 mm. A series of sampling ports are attached to the wall of the outer column. The space between each port is fixed at 0.4 m. A porous sparger for air dispersion in the airlift reactor is located at bottom of the inner column (riser). The employed packing is a commercial plastic bioball which is crushed by a crushing machine. The total volume of liquid in the bioreactor is 5 litres. Fig 3.2 showed the packing in airlift fluidized bed reactor.

Specifications

Volume = 5 L

$A_d/A_r = 1.56, 2.78$

Superficial gas velocity = 1, 1.7 and 2.3 cm/s

Specific surface area of packing is 1.44 and 0.72 cm^2/cm^3 for AFBR with A_d/A_r 1.56 and 2.78, respectively (Fig. 3.9 showed crushed bioball packing and bioball packing)

Bioreactor height = 1.20 m

Downcomer diameter = 0.1 m

Riser diameter = 0.08 m, 0.06m

B. Packed Bed Airlift Filter (Fig 3.3)

The packed bed column has the same dimension as the fluidized bed airlift filter described above. The employed packing is a commercial bioball which is spherical in shape (uncrushed) with a radius of 2.54 cm. The packing is supported by an aluminum, perforated plate installed at the bottom of the aerated section of the reactor. The total

volume of media installed in the airlift column is 0.00113 m^3 (only in riser: height 40 cm, diameter 6 cm). Fig 3.4 showed the packing in airlift packed bed reactor.

Specifications

Volume = 5 L

$A_d/A_r = 1.56, 2.78$

Superficial gas velocity = 1, 1.7 and 2.3 cm/s

Specific surface area of packing is 1.31 and $0.65 \text{ cm}^2/\text{cm}^3$ for AFBR with A_d/A_r 1.56 and 2.78, respectively

Bioreactor height = 1.20 m

Downcomer diameter = 0.1 m

Riser diameter = 0.08 m, 0.06m

C. Trickle Filter (Fig. 3.5)

The trickle filter is also constructed of a transparent acrylic plastic with 5 mm wall thickness. The water is pumped to the top of the trickle filter and distributed over the top of the media by a spray disc. This commercial bioball packing is supported by a ventilating channel aluminum plate which is installed at the bottom of the column.

Specifications

Volume = 5 L

Inner diameter = 0.2 m

Liquid circulating velocity = 0.103 m/s

Specific surface area of plastic bioball packing is $3.028 \text{ cm}^2/\text{cm}^3$

Bioreactor height = 0.2 m

Bioreactor diameter = 0.2 m

D. Submerged Filter (Fig. 3.6)

The submerged filter, also made of clear acrylic plastic, is coupled with a series of sampling ports along the column height with a distance of 0.4 m between each port. The bioball packing is used here as a supporting media for the microorganism. This packing is supported by an aluminum, perforated plate installed at the bottom section of the column. A porous sparger for air dispersion in the submerged reactor, is located at the very bottom of column. Fig. 3.7 showed the packing in submerged filter.

Specifications

Volume = 5 L

Superficial gas velocity = 1, 1.7 and 2.3 cm/s

Specific surface area of plastic bioball packing is 1.31 and 0.65 cm²/cm³

Bioreactor height = 1.20 m

Bioreactor diameter = 0.1 m

The schematic diagrams of these experimental setups are given in Figures 3.1, 3.2, 3.3, 3.4 and 3.8. In all experiments, nitrification in synthetic seawater was performed in the systems with immobilized nitrifying bacteria. These reactors were operated at atmospheric pressure and room temperature whereas the initial NH₄-N concentration are 10 mg NH₄-N/L. The initial oxygen concentration was set at zero by purging pure nitrogen into the column. A DO meter (Hanna HI 964400) was located inside each column to monitor DO level. It was important that DO level during the operation be greater than 3 ppm to ensure efficient biodegradable process of nitrifying bacteria.

3.2 Experimental procedures

3.2.1 Preparation of immobilized nitrifying bacteria

Nitrifying bacteria are immobilized on plastic bioballs by immersing plastic bioballs in a synthetic shrimp cultured solution for 2 weeks. This solution is prepared by adding 1 g/L of shrimp feeding into a synthetic seawater at the salinity of 30 ppt. An oyster shell with nitrifying bacteria is also added into this solution as an initial inoculation. Aeration was also supplied in this inoculation tank into this solution.

3.2.2 Nitrification experiment

- 1) Prepare synthetic wastewater with seawater a salinity of about 30 ppt.
- 2) Fill synthetic wastewater in all four systems.
- 3) Add ammonium chloride (NH₄Cl) at 2 mg NH₄Cl/L for initial bacterial growth.
- 4) Allow the system to run for about 15 minutes to reach a well-mixed condition.

- 5) Take a 50 mL sample from a sampling port to measure initial concentrations of ammonium-nitrogen ($\text{NH}_4 - \text{N}$), nitrite-nitrogen ($\text{NO}_2 - \text{N}$) and nitrate-nitrogen ($\text{NO}_3 - \text{N}$) by the Strickland and Parson method (1972).
- 6) Take a sample to measure $\text{NH}_4 - \text{N}$, $\text{NO}_2 - \text{N}$ and $\text{NO}_3 - \text{N}$ daily, until the concentration of ammonium-nitrogen ($\text{NH}_4 - \text{N}$) is close to zero.
- 7) Add ammonium chloride (NH_4Cl) to synthesis wastewater to make a 10 mg $\text{NH}_4 - \text{N/L}$ solution.
- 8) Allow synthetic wastewater to mix in all reactors for 15 minutes, collect samples for the determination of initial concentration of ammonium-nitrogen ($\text{NH}_4 - \text{N}$), nitrite-nitrogen ($\text{NO}_2 - \text{N}$) and nitrate-nitrogen ($\text{NO}_3 - \text{N}$).
- 9) Take sample to measure $\text{NH}_4 - \text{N}$, $\text{NO}_2 - \text{N}$ and $\text{NO}_3 - \text{N}$ daily.
- 10) Measure dissolved oxygen in the dispersion by dissolved oxygen (DO) meter (Hanna HI 964400).
- 11) Repeat experiment in AFBR and APBR with various A_d/A_r and superficial gas velocity as specified in Section 3.1 (A).

During the experiment, make-up synthesis wastewater was added to replace the volume lost in sampling procedure. Evaporation loss was replaced by distilled water.

The nitrification rate is calculated from [Kamstra,1998]

$$R_f = \frac{([\text{NH}_4 - \text{N}]_{\text{in}} - [\text{NH}_4 - \text{N}]_{\text{out}}) \cdot Q}{V \cdot s} \quad (3-1)$$

where

| | | |
|-----------------------------------------|---|-----------------------------------------------------------------------------|
| R_f | = | overall biofilter ammonium removal rate ($\text{g m}^{-2} \text{d}^{-1}$) |
| $[\text{NH}_4 - \text{N}]_{\text{in}}$ | = | ammonium concentration in influent (g m^{-3}) |
| $[\text{NH}_4 - \text{N}]_{\text{out}}$ | = | ammonium concentration in effluent (g m^{-3}) |
| Q | = | total flow over filter ($\text{m}^3 \text{d}^{-1}$) |
| V | = | volume of filter bed (m^3) |
| s | = | specific surface of medium used ($\text{m}^2 \text{m}^{-3}$) |

3.2.3 Nitrification Condition

- 1) The alkalinity as measured in NaH_2CO_3 was adjusted at approximately 0.5 M NaH_2CO_3 30 ml.
- 2) The optimum pH range 7.0-8.0.
- 3) Dissolved oxygen level more than 3 mg/L (saturated dissolved oxygen).
- 4) Ammonium chloride (NH_4Cl) to synthesis wastewater to make a 10 mg $\text{NH}_4 - \text{N/L}$ solution.
- 5) Salinity of synthesis wastewater about 30 ppt.

3.3 Experimental measurement

3.3.1 Measurements for Hydrodynamic and mass transfer parameter

A. Measurement of overall gas holdup

- 1) Read the value of liquid dispersion height and unaerated liquid height.
- 2) Determine the overall gas holdup by the volume expansion method. The expanded dispersion volume represents the volume of gas in the system according to the following equation:

$$V_G = V_D - V_L \quad (3-2)$$

where

V_G = expanded gas volume or overall gas volume (cm^3)

V_D = dispersed liquid volume (including solid volume) (cm^3)

V_L = unaerated liquid volume (including solid volume) (cm^3)

The fluid volume in the system can be calculated from the product between cross sectional area (A) and fluid height (H):

$$V = AH \quad (3-3)$$

hence,

$$V_D = AH_D \quad (3-4)$$

and

$$V_L = AH_L \quad (3-5)$$

where

A = cross sectional area of the column (cm^2)

H_D = dispersion height (cm)

H_L = unaerated liquid height (cm)

If ε_0 is the gas fraction in the expanded fluid volume in the contactor, one can calculate the overall gas holdup by:

$$V_G = \varepsilon_0 AH_D \quad (3-6)$$

Combining Equations 3-1, 3-4, 3-5 and 3-6 yields:

$$\varepsilon_0 AH_D = AH_D - AH_L \quad (3-7)$$

$$\varepsilon_0 = \frac{(H_D - H_L)}{H_D} \quad (3-8)$$

The unaerated liquid height and dispersion height can be measured and hence, the overall gas holdup can be calculated accordingly.

ศูนย์วิทยทรัพยากร
จุฬาลงกรณ์มหาวิทยาลัย

B. Measurement of downcomer gas holdup

- 1) Fill tap seawater into airlift reactor (only fluidized bed airlift filter and packed bed airlift filter) then disperse compressed air from an air pump continuously into the reactor through a sparger.
- 2) Adjust superficial gas velocity (u_{sg}) to the desired value by using a calibrated rotameter.

- 3) Measure pressure difference between two positions (ΔP) in annular section by water manometer to evaluate gas holdup in the annular section. However gas holdup in a draft tube section cannot be measured directly so this value is subsequently calculated using information on overall and annulus gas holdups.

For gas holdup in the downcomer (gas holdup in the annular section):

$$\Delta P_{column} = \Delta P_{manometer} \quad (3-9)$$

$$\rho g(H_D - H_I) = \rho_L g \Delta z \quad (3-10)$$

where ρ on the left hand side represents the density of the dispersion:

$$(\rho_{Ls} \varepsilon_L + \rho_g \varepsilon_g) g(H_D - H_I) = \rho_L g \Delta z \quad (3-11)$$

Neglecting the acceleration and wall-friction contribution in the momentum balance and with $\rho_{Ls} \gg \rho_g$, it is reasonable to neglect the second term in the first bracket on the left hand side of Equation 3-11 and this leads to:

$$\rho_{Ls} \varepsilon_L g(H_D - H_I) = \rho_L g \Delta z \quad (3-12)$$

$$\frac{\rho_{Ls}}{\rho_L} \varepsilon_L (H_D - H_I) = \Delta z \quad (3-13)$$

since

$$\varepsilon_L = 1 - \varepsilon_{gd} \quad (3-14)$$

Equation (3-13) becomes

$$\frac{\rho_{Ls}}{\rho_L} (1 - \varepsilon_{gd}) (H_D - H_I) = \Delta z \quad (3-15)$$

$$\varepsilon_{gd} = 1 - \frac{\Delta z}{(H_D - H_l)} \left(\frac{\rho_{Ls}}{\rho_L} \right) \quad (3-16)$$

where

ε_{gd} = gas fraction in downcomer

ε_L = liquid fraction in downcomer

ρ_{Ls} = seawater density (1.02 g/cm³)

ρ_L = fresh water density (1 g/cm³)

Δz = difference of liquid height in manometer, measuring at point

H_l

H_l = height of measuring port in gas separator at 40 cm. from the bottom of the column (cm)

g = gravitational acceleration (cm/s²)

It is assumed that the gas holdup in the top section is approximately equal to that in the riser. This allows the estimation of the riser gas holdup (gas holdup in the tube) from the overall and downcomer gas holdups. The relationship between the gas holdups in different parts of an airlift reactor can be written as:

$$\varepsilon_0 V_T = \varepsilon_{gr} V_{gr} + \varepsilon_d V_d + \varepsilon_t V_t \quad (3-17)$$

where

ε_0 = over all gas holdup(%)

ε_{gr} = gas fraction in riser

ε_t = gas holdup in top section

$$\varepsilon_0 H_D (A_d + A_r) = \varepsilon_{gr} A_r H_{DT} + \varepsilon_d A_d H_{DT} + \varepsilon_t A_t H_t \quad (3-18)$$

Rearrange this equation to give:

$$\varepsilon_0 = \frac{H_{DT}A_{gr}\varepsilon_{gr} + H_{DT}A_d\varepsilon_d + (H_D - H_{dt})(A_d + A_r)\varepsilon_t}{H_D(A_d + A_r)} \quad (3-19)$$

Substituting $\varepsilon_{gr} = \varepsilon_t$ into Eq. (19) yields:

$$\varepsilon_0 = \frac{H_{DT}A_d\varepsilon_d + (H_D A_d + H_D A_r - H_{dt} A_d)\varepsilon_t}{H_D(A_d + A_r)} \quad (3-20)$$

or

$$\varepsilon_r = \frac{H_D\varepsilon_0(A_d + A_r) - H_{DT}A_d\varepsilon_d}{H_D A_d + H_D A_r - H_{dt} A_d} \quad (3-21)$$

C. Liquid velocity measurement

- 1) Fill tap seawater into the concentric tube internal loop airlift reactor until liquid level (H_L) reaches the desired level .
- 2) Disperse compressed air from an air compressor continuously into the reactor through a sparger.
- 3) Adjust superficial gas velocity (u_{sg}) to the desired value by using a calibrated rotameter.
- 4) Inject dye tracer into the annular section of the airlift reactor to measure liquid velocities in both annular and draft tube sections. The motion of dye tracer is observed virtually and a stopwatch is used to measure the time tracer uses to move between 2 positions.
Notes: - After the liquid velocity measurement by dye tracer, the liquid may not be clear enough to observe on-going phenomena. For this reason, before next experiment is carried out the colored liquid should be drained and new clear water should be re-filled.
- 5) Repeat Steps (1) to (4) using new geometrical and/or operating parameters.

Calculation

With the experimental data on the traveling time of tracer between the two points in the contactor, liquid velocities both in riser and downcomer can be evaluated by Eq. (3-22) and (3-23), respectively.

$$v_{Lr} = \frac{L_r}{t_r} \quad (3-22)$$

$$v_{Ld} = \frac{L_d}{t_d} \quad (3-23)$$

D. Mass transfer measurement

The overall volumetric mass transfer coefficient ($k_L a$) was determined by the dynamic gassing in method. A dissolved oxygen meter (Hanna HI 964400) was used to record the changes in concentration of O_2 in a batch of seawater that had previously been freed of O_2 by bubbling through with N_2 . Experimental methods follow:

- 1) Fill tap seawater into the concentric tube internal loop airlift reactor until liquid level (H_L) reaches the desired level.
- 2) Immerse the dissolved oxygen probe into the water in the reactor.
- 3) Disperse nitrogen gas at the base of the reactor to remove dissolved oxygen from the water.
- 4) Measure dissolved oxygen concentration in the seawater by dissolved oxygen meter to ensure that all of the oxygen has been removed.
- 5) Stop the nitrogen gas flow.
- 6) Distribute compressed air from an air pump continuously into the reactor through a sparger.

Notes: - The value at the rotameter is set to give a desired level of superficial gas velocity.

- 7) Record the dissolved oxygen concentration with respect to time as soon as air is distributed into the reactor until the seawater is saturated with oxygen.
- 8) Repeat Steps 1) to 7) using new geometrical and/or operating parameters.

Calculation

The $k_L a$ is determined by using the dynamic method which is described briefly as follows.

From the mass balance of oxygen in this system:

$$\frac{dC}{dt} = k_L a (C^* - C) = K_L a (C^* - C) \quad (3-24)$$

Integrate Eq. (3-24) with the limits of $C = C_0$ at $t = 0$ and $C = C$ at $t = t$ results in:

$$\int_{C_0}^C \frac{dC}{(C^* - C)} = k_L a \int_0^t dt \quad (3-25)$$

The result of integration is

$$\ln \left[\frac{C^* - C_0}{C^* - C} \right] = k_L a t \quad (3-26)$$

The value of $k_L a$ is obtained from the slope of the linear regression with $\ln \left[\frac{C^* - C_0}{C^* - C} \right]$ with respect to time (t).

3.3.2 Analytical methods for measuring nitrogen compounds [Strickland and Parson, 1972]

A. Ammonium-nitrogen concentration measurement

Reagent solutions

- 1) De-ionized water
- 2) Phenol solution
 - Dissolve 20 g of crystalline phenol in 200 mL of 95% v/v ethyl alcohol.
- 3) Sodium nitroprusside solution

- Dissolve 1.0 g of sodium nitroprusside ($\text{Na}_2\text{Fe}(\text{CN})_5\text{NO}\cdot 2\text{H}_2\text{O}$) in 200 mL of deionized water. Store in an amber bottle. The solution is stable for at least 1 month.
- 4) Alkaline reagent
 - Dissolve 100 g of sodium citrate and 5 g of sodium hydroxide (analytical reagent grade) in 500 mL of de-ionized water. This solution is stable indefinitely.
- 5) Sodium hypochlorite solution (1.5N)
- 6) Oxidizing solution
 - Mix 100 mL of reagent 4 and 25 mL of reagent 5. Keep this solution stoppered while it is not in use. Prepare fresh everyday.

Procedure

- 1) Add 5 mL of sample to a tube from a 5 mL pipette.
- 2) Add 0.2 mL of phenol solution, from a pipette, swirl the solution
- 3) Add 0.2 mL of sodium nitroprusside solution and 0.5 mL of oxidizing solution.
- 4) Mixing after each addition.
- 5) Allow the tube to stand at temperature between 20-27 °C for 1 h. The top of the tube should be covered with aluminum foil at this storage to lessen the contamination by atmospheric ammonia.
- 6) Read the absorbance at 640 nm in a spectrophotometer against distilled water using 10-cm cells.
- 7) Correct the measured absorbance by that of a reagent blank and read the ammonia-nitrogen concentration from the standard calibration curve.

Blank

- Carry out the method exactly as described in (1) to (6) above using freshly deionized water. Blank absorbance using a 10-cm cell should not exceed 0.075.

Calibration

Standard ammonia solution

- Dissolve 0.1 g. of ammonia sulfate in 1000 mL of de-ionized water.
- Add 1 mL of chloroform
- Store this solution in refrigerant (This solution is stable).
- The amount of ammonia in 1 mL of the prepare solution is equal to 0.021mg $\text{NH}_3\text{-N}$.

B. Nitrite-Nitrogen concentration measurement

Reagents

1) Sulphanilamide solution

- Dissolve 5 g of sulphanilamide in a mixture of 50 mL of concentrated hydrochloric acid and 300 mL of distilled water.
- Dilute to 500 mL with water (the solution is stable for many months).

2) N-(1-Naphthyl)-ethylenediamine dihydrochloride solution (NNED solution)

- Dissolve 0.5 g of dihydrochloride in 500 mL of distilled water.
- Store the solution in a dark bottle. (The solution should be renewed once a month).

Procedure

- 1) Add 5 mL of sample to the tube with a 5 mL pipette.
- 2) Add 0.1 mL of sulphanilamide solution, from automatic pipette to each sample, mix, and allow the reagent to react for between 2 and 8 min.
- 3) Add 0.1 mL of naphthylenediamine solution and mix immediately. Between 10 min and 1 h afterwards measure the absorbance at 543 nm in a spectrophotometer.
- 4) Correct the measured absorbance by subtracting reagent blank and read the nitrite-nitrogen concentration from a standard calibration curve.

Calibration

Standard nitrite solution

- Dry anhydrous sodium nitrite (NaNO_2) at 110°C for 1 h.
- Dissolve 0.345 g of anhydrous sodium nitrite in 1000 mL of distilled water
- Add 1 mL of chloroform as a preservative.
- Store the solution in dark bottle (the solution is stable for at least 1-2 months).
- The amount of nitrite in 1 mL of the prepare solution is equal to 0.005 mg $\text{NO}_2\text{-N}$.

Blank

Synthetic seawater solution

- Dissolve 310 g of sodium chloride (NaCl), 100g of magnesium sulphate ($\text{MgSO}_4 \cdot 7\text{H}_2\text{O}$) and 0.5 g of sodium bicarbonate ($\text{NaHCO}_3 \cdot \text{H}_2\text{O}$) in 10 L of distilled water.

C. Nitrate-nitrogen concentration measurement

Reagents

Use redistilled or distilled, deionized water of highest purity to prepare all solutions and dilutions.

Procedure

- 1) Measure absorbance at wavelength of 220 nm to obtain NO_3^- reading by subtracting reagent blank.
- 2) Use a wavelength of 275 nm to determine interference due to dissolved organic matter by subtracting reagent blank.

Calibration

Standard nitrate solution

- Dissolve 1.02 g of analytical reagent quality potassium nitrate (KNO_3) in 1000 mL of distilled water (the solution is stable indefinitely in the absence of evaporation).
- The amount of nitrate in 1 mL of the prepare solution is equal to 0.01 mg $\text{NO}_3\text{-N}$.

Blank

Read absorbance of transmittance against reditilled water set zero absorbance or 100% transmittance.

ศูนย์วิทยทรัพยากร
จุฬาลงกรณ์มหาวิทยาลัย

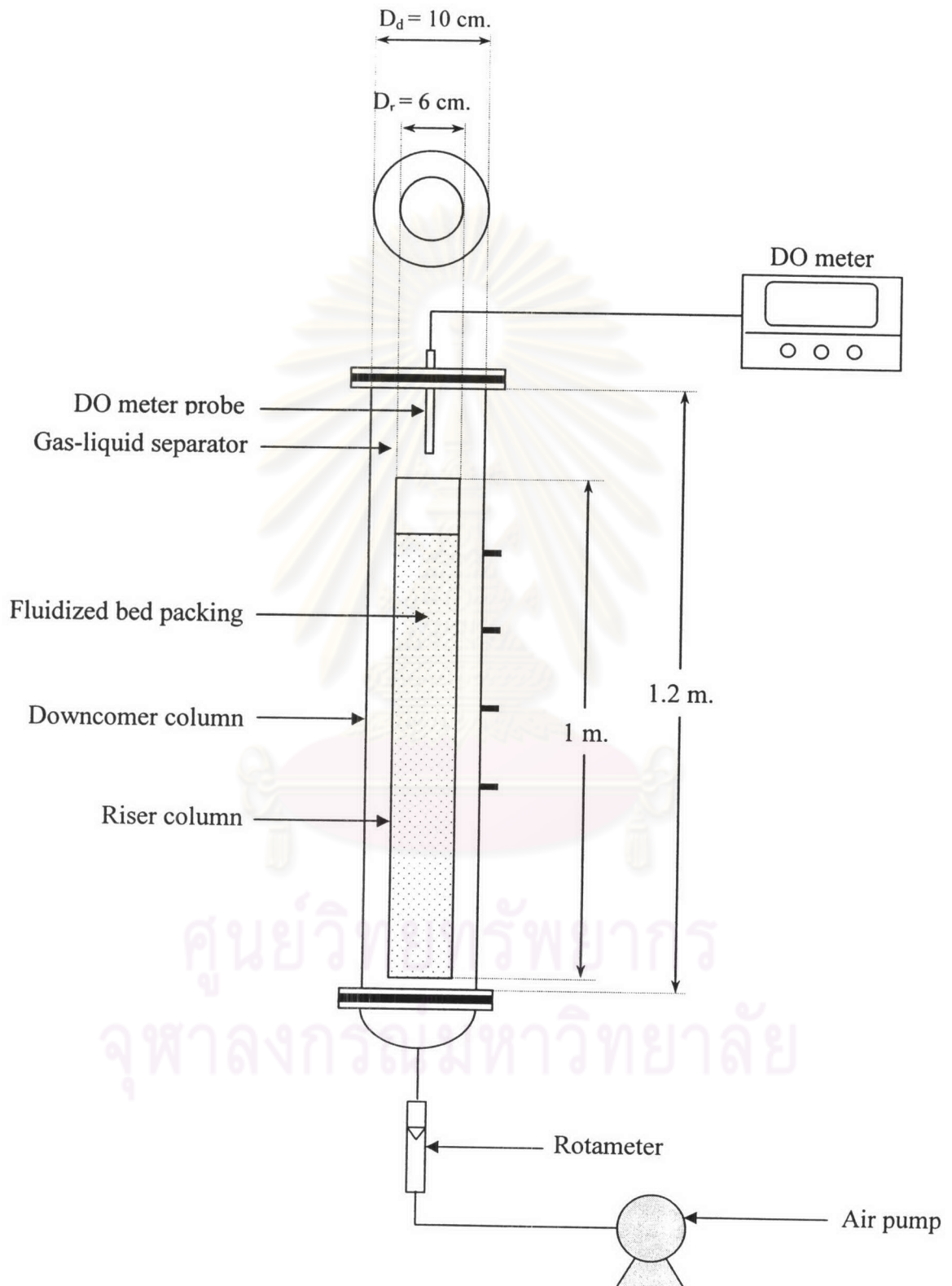

Figure 3.1 Fluidized bed airlift filter

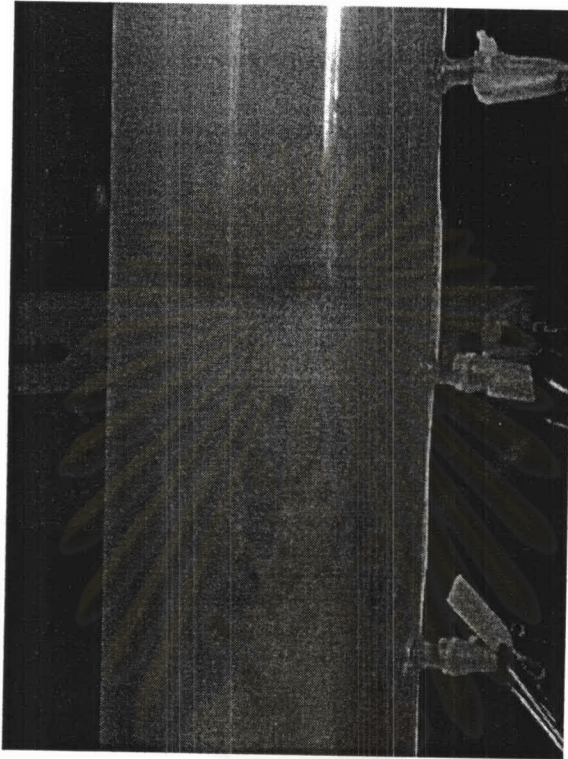

Fig. 3.2 Packing in fluidized bed airlift filter

ศูนย์วิทยทรัพยากร
จุฬาลงกรณ์มหาวิทยาลัย

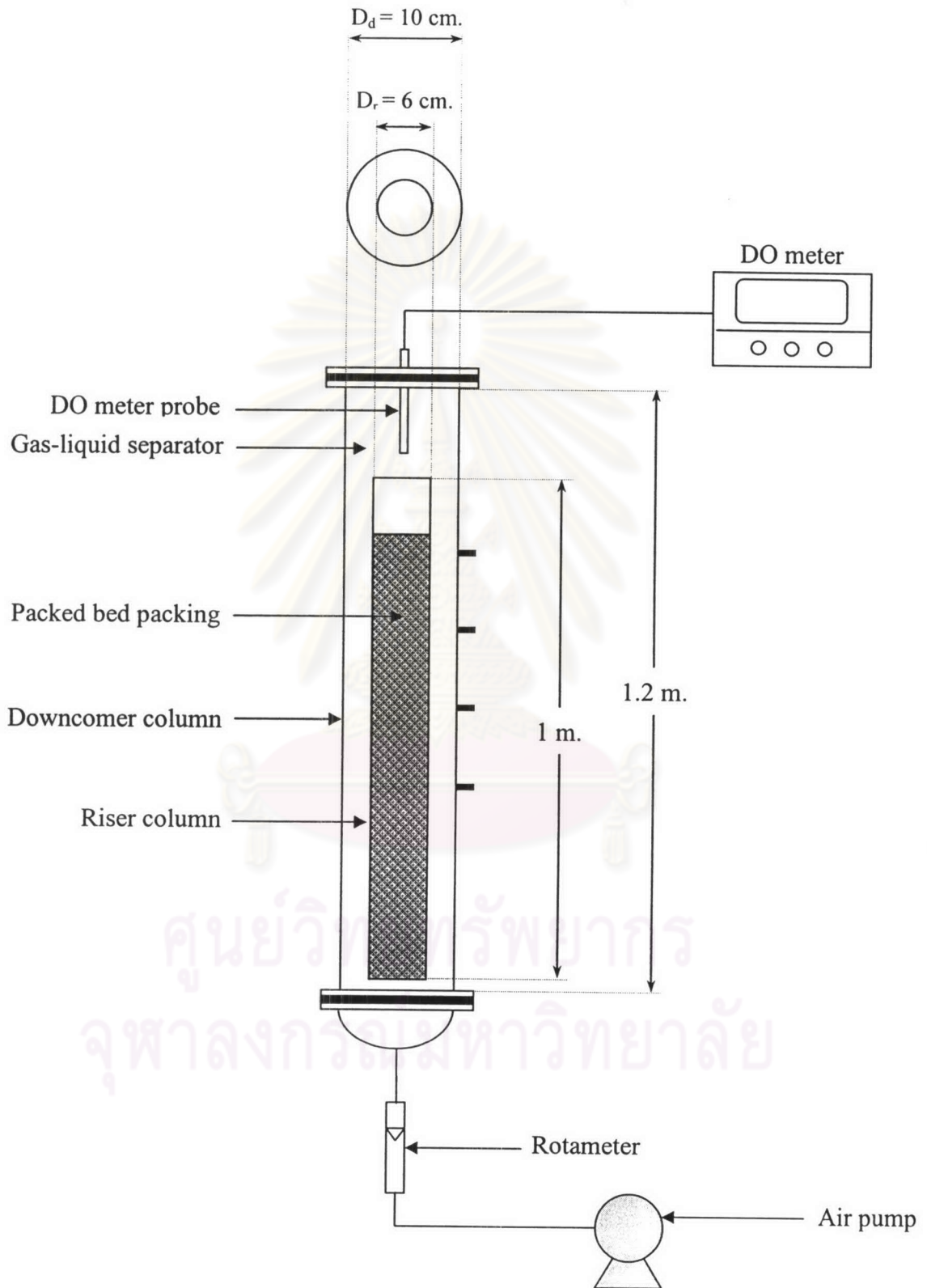

Figure 3.3 Packed bed airlift filter

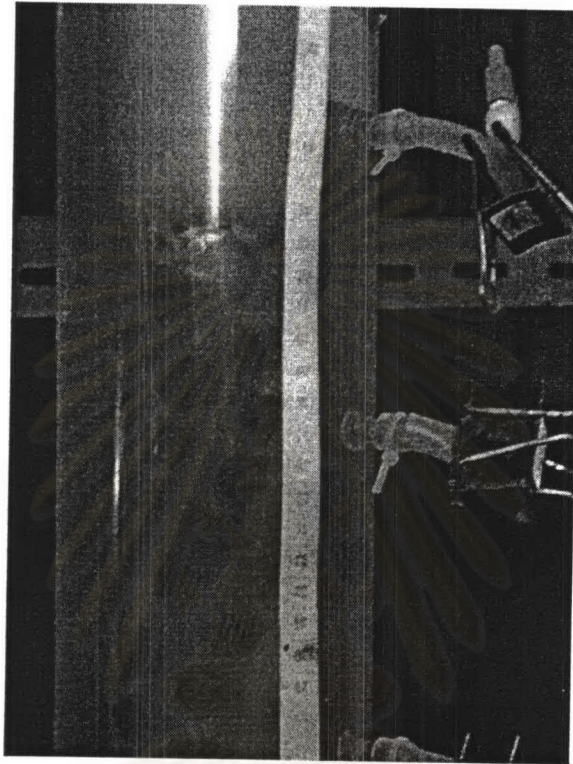

Fig. 3.4 Packing in packed bed airlift filter

ศูนย์วิจัยทรัพยากร
จุฬาลงกรณ์มหาวิทยาลัย

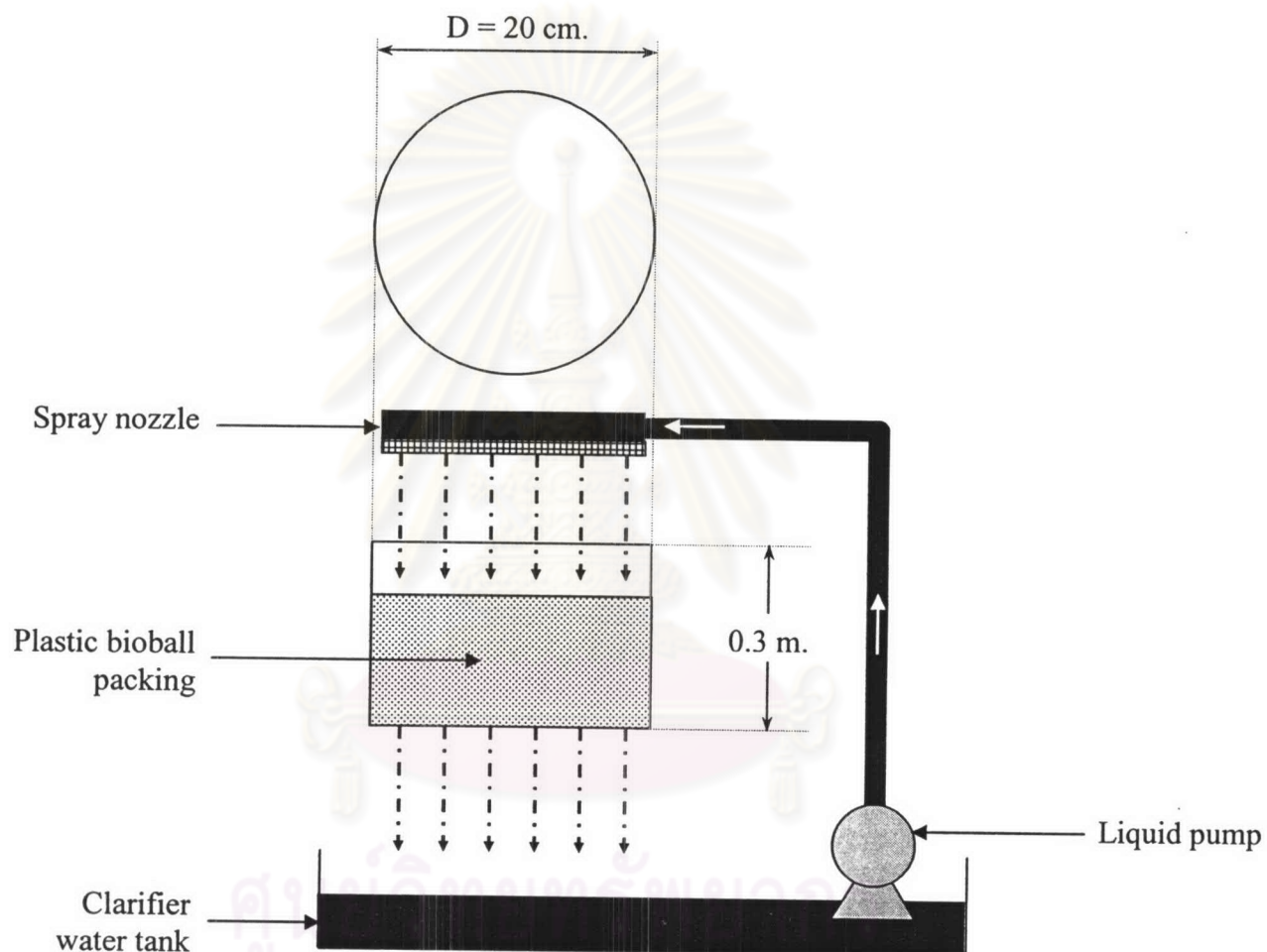

Figure 3.5 Trickling Filter

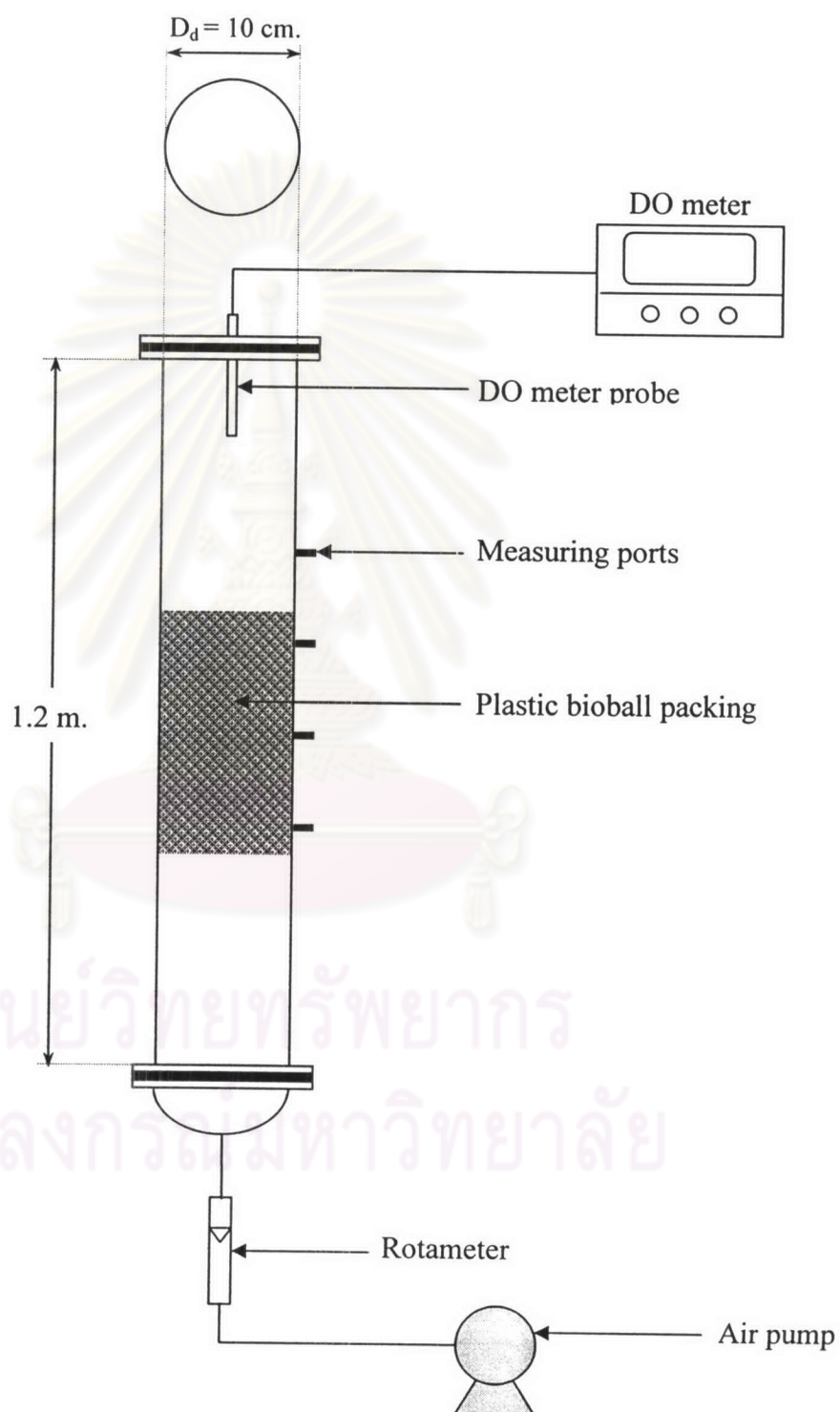

Figure 3.6 Submerged filter



Fig 3.7 Packing in submerged filter

ศูนย์วิทยทรัพยากร
จุฬาลงกรณ์มหาวิทยาลัย

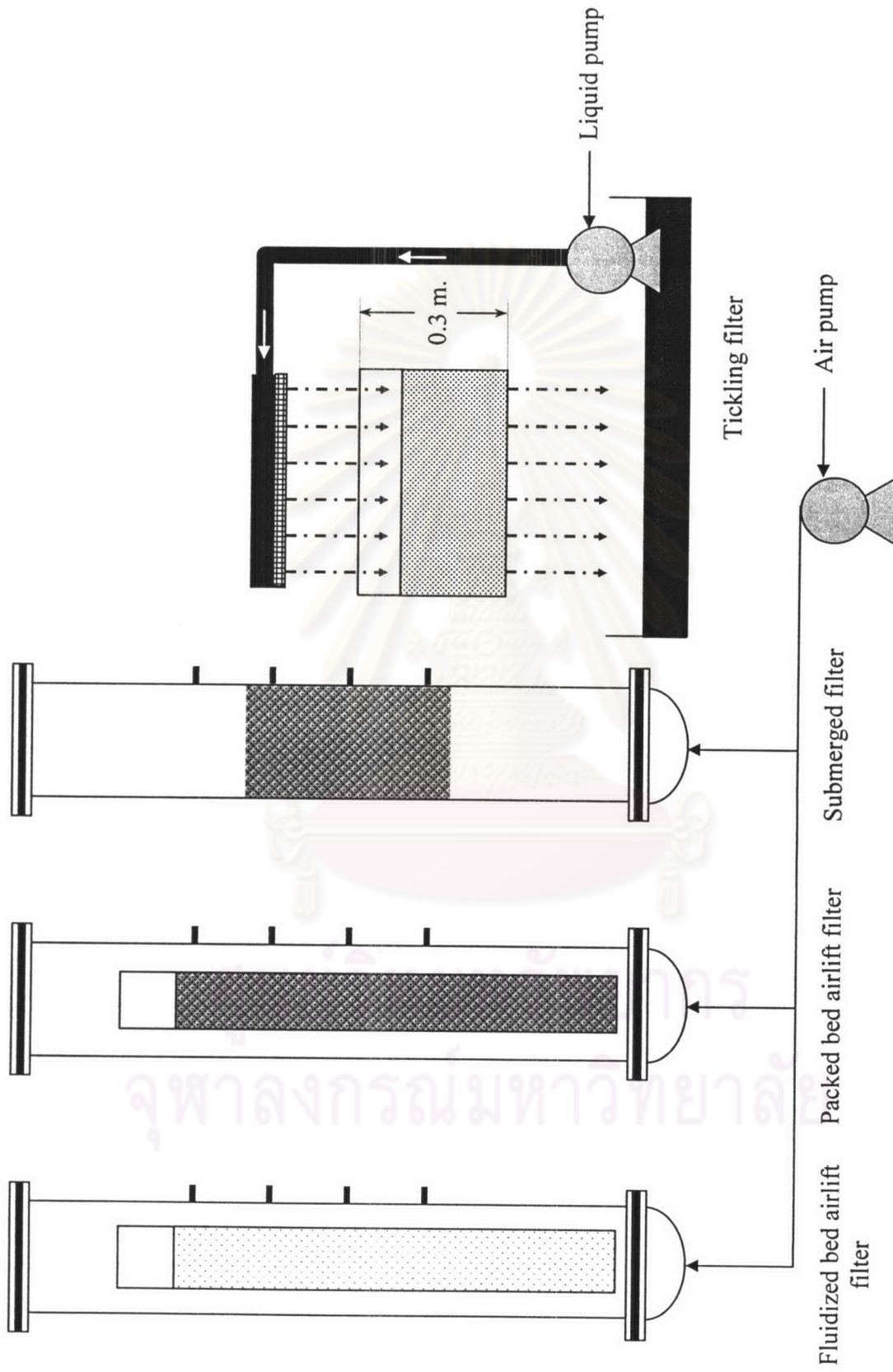

Figure 3.8 Schematic diagram of nitrification filter employed in this work



Figure 3.9 Crushed bioball and bioball packing used in the experiments

ศูนย์วิทยทรัพยากร
จุฬาลงกรณ์มหาวิทยาลัย