

CHAPTER II

THEORY AND LITERATURE REVIEW

2.1 Nuclear spectroscopy system

2.1.1 Signal pulse processing. A principal block diagram of a nuclear spectroscopy system is shown in Fig. 2.1. The system comprises of radiation detector, HV supply, preamplifier, spectroscopy amplifier, and pulse height analyzer. The system is essential for nuclear spectrum analysis in various kinds of radiation i.e. alpha; beta, gamma, neutron and x-ray, spectrometer which depends on the radiation detector response.

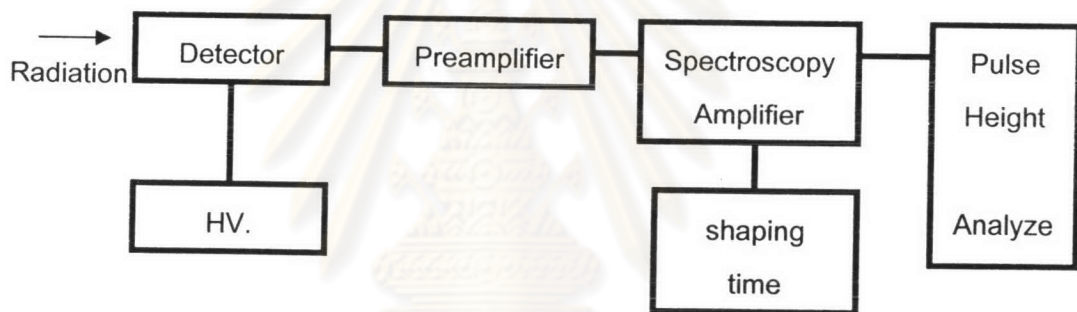

Fig. 2.1 A principal block diagram of nuclear spectroscopy system.

The incident radiation at the sensitive volume of detector is detected by converting the energy to a discrete amount of charges in proportion to the absorbed energy. A voltage pulse amplitude (height) representing the burst of charge at specific energy is generated via preamplifier. At the same time, noise can be established at any part of the front-end and added to signal chain of preamplifier. Therefore, the spectroscopy amplifier will be designed not only for gaining the signal pulse but also for the signal to noise ratio improvement through using the noise filter or signal wave shaper, shown as a functional diagram in Fig. 2.2

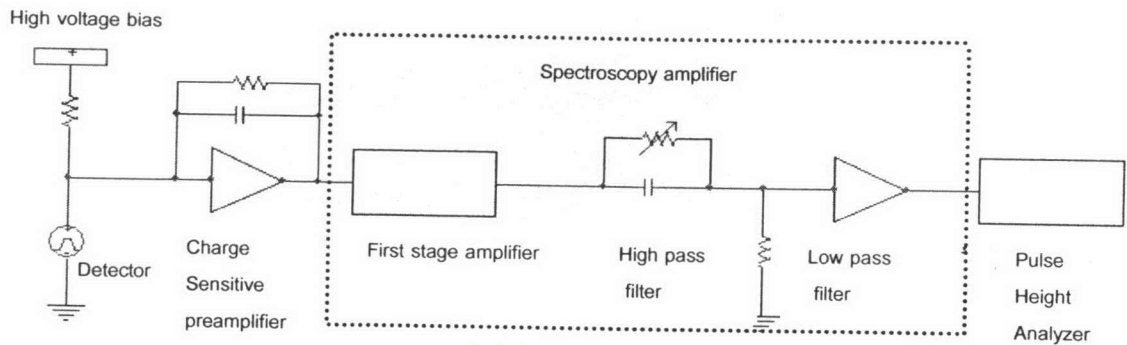

Fig. 2.2 A Functional diagram of signal chain.

A low-noise charge sensitive preamplifier is used at the front end because of its low noise configuration and insensitivity of the gain due to the detector capacitance variation. The generated charge is integrated onto a suitable feedback capacitance, which gives rise to a tiny step voltage signal at the output of the charge sensitive preamplifier with an amplitude corresponding to the ratio between the generated charges and feedback capacitance. A staircase voltage is formed when a train of radiation interacts within media of radiation detector, as shown in Fig. 2.3b. Each step voltage with amplitude in proportion to the amount of charge generated by radiation contributes to the voltage pile-up. After it reaches the saturation level the system will be reset to ground level and remains steady until the new event comes.

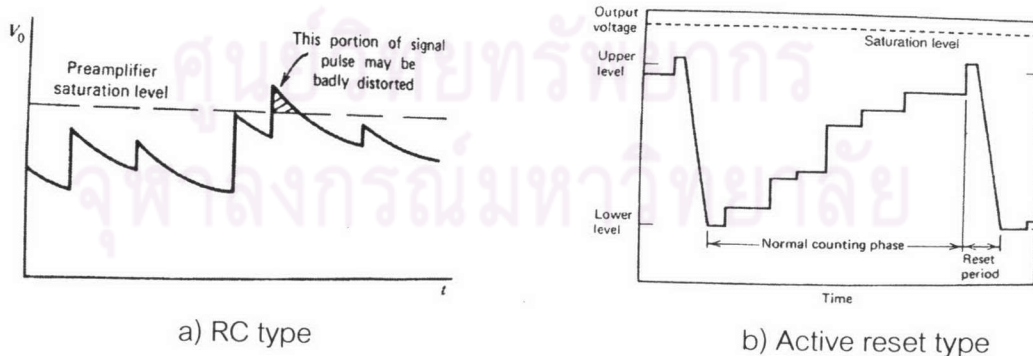

Fig. 2.3 Illustration of an output signal of RC and active reset preamplifier

Next stage, each step signal is fed to main amplifier where signal is filtered or shaped. This primarily optimizes the signal-to-noise ratio of the system.

Figure 2.4 shows the signal output at different filter shaping times. The output pulses are also different in shape. A small shaping time gives a narrow output pulse while a large shaping time gives a wider output. At this stage, noise is considerably removed from the output signal. The error associated with signal is made small, but the optimum one is still to be identified. In all cases, one of the resulting output signals may be performed as a suitable pulse for further processing or analyzing depending on its applications. In above mentioned system, the signal processing chain in nuclear spectrometer acts as pulse shaping unit yielding output signals with pulse heights proportional to the amount of charges released from the detector.

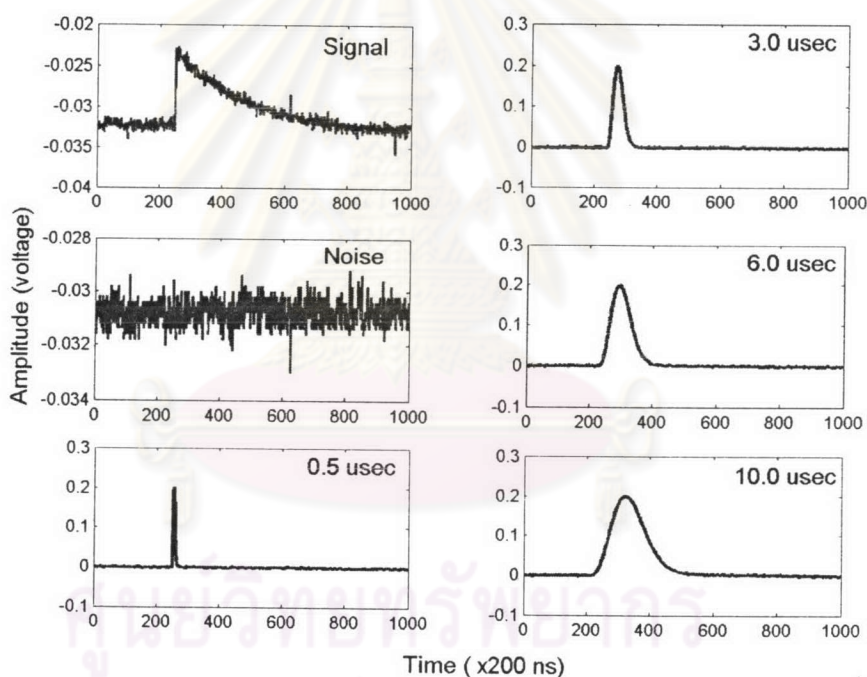

Fig. 2.4 The signal outputs at different filter shaping time.

The final stage in signal pulse processing is the pulse height analyzer, single channel analyzer (SCA) or multi-channel analyzer (MCA) which is used to analyze the pulse height and form pulse height distribution. Pulse height analyzer is substantial in measuring the different pulse heights and recording each individual quantum of radiation that interacts in the detector. The signal pulse height analyzer works on the basis of pulse height discrimination. A system might count the signals, which have the

same amplitude and store in the counter or scaler and produce the histogram of signal amplitude from a detector as shown in Fig. 2.5a. Owing to the presence of noise, there occurs pulse height fluctuation resulting in pulse height broadening as shown in Fig. 2.5b

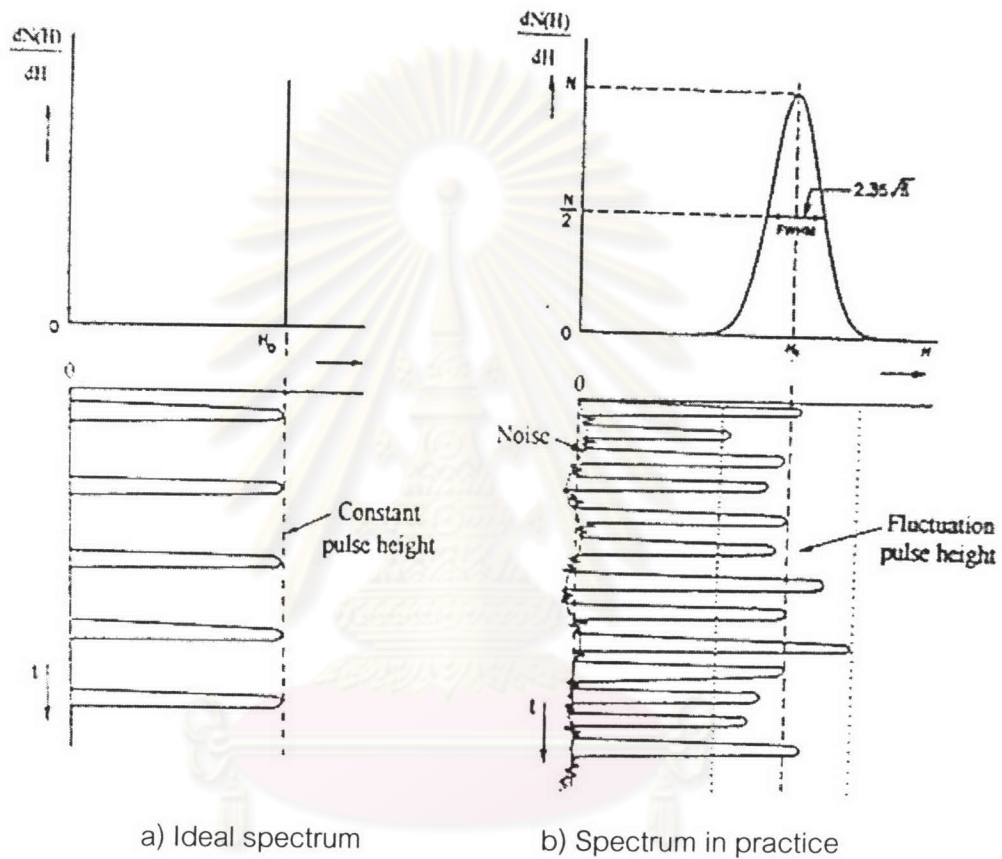

Fig. 2.5 Illustration of pulse height distribution.

In practice, radiation of different energies are emitted and detected in the nuclear spectroscopy system. Therefore, the pulse height distribution profile is formed also known as the energy spectrum. Basically, the sharp shape of a pulse height distribution, called "energy resolution", at each energy peak depends predominantly on the type of detectors. The comparative pulse height spectra recorded using a NaI(Tl) scintillation counter and Ge(Li) detector is illustrated in Fig. 2.6. Moreover, an energy resolution of each spectrum can be degraded by a combination of many factors to be mentioned in the next section.

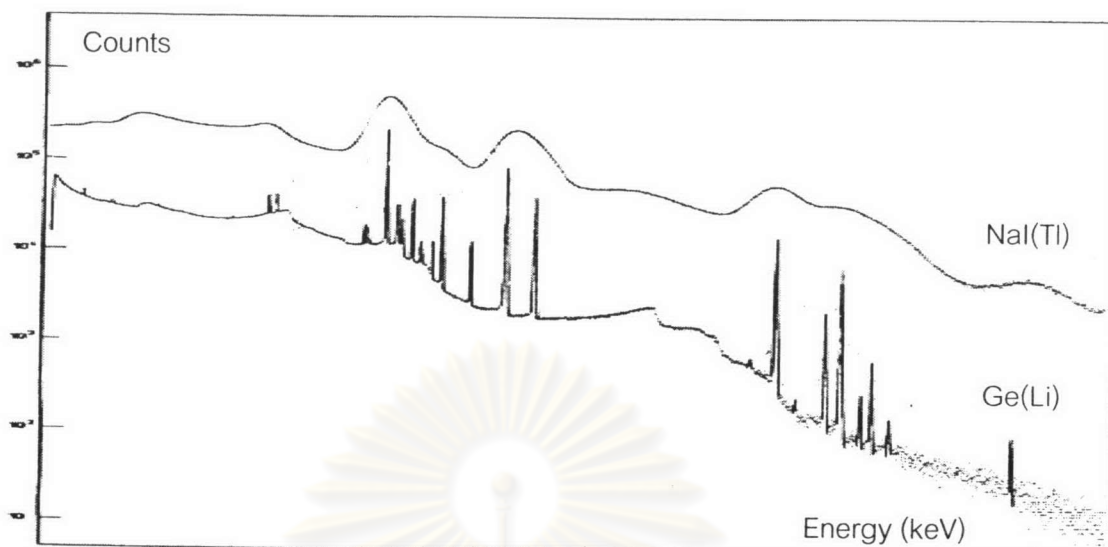

Fig. 2.6 Energy spectrum of NaI and semi conductor detector Ge(Li) from pulse height analyzer.

2.1.2 Energy resolution degradation. The imperfection of detection system and the pulse processing give rise to the finite width of the peak in the spectrum. The Full Width at Half Maximum (FWHM) of peak due to the monoenergetic nuclear particle is the definition of the resolution of nuclear spectroscopy system. The FWHM is widely used as index of resolution of a spectroscopy system and is alternative to the standard deviation, σ , of the pulse height of signal arriving at the analyzer. The peak in the pulse height spectrum can be approximated by Gaussian distribution, which has the mean energy, H_0 , and the standard deviation of pulse heights, as shown in Fig. 2.7

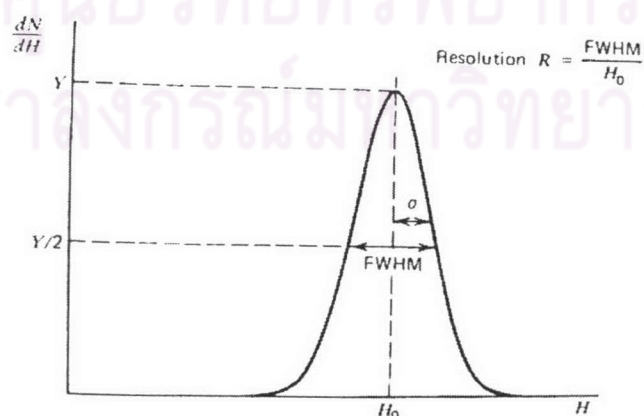

Fig. 2.7 Definition of system resolution.

The Gaussian function most conveniently is given as:

$$G(H) = \frac{A}{\sigma\sqrt{2\pi}} e^{-(H-H_0)^2/2\sigma^2} \quad (2.1)$$

The width parameter σ determines the FWHM of Gaussian through the relation of 0.5 probabilities at average pulse height, and can be derived as

$$\begin{aligned} 1/2 &= e^{-\Delta H^2/2\sigma^2} \\ \Delta H &= \sqrt{2 \ln 2} \cdot \sigma \\ FWHM &= 2\Delta H = 2.35\sigma \end{aligned} \quad (2.2)$$

The energy resolution (R) is calculated from the ratio of FWHM and average pulse height (H_0) or in other term of energy as FWHM at average energy (E).

$$R = \frac{FWHM}{H_0} = \frac{FWHM}{E} \quad (2.3)$$

The source of fluctuation in a signal processing chain will combine statically fluctuations from the detector to give the overall energy resolution of spectroscopy system. Fluctuation sources degrading the energy resolution in term of standard deviation, σ , comprise of four components. The first one is σ_1 , the nature of detection process in a detector, is represented by the fluctuation in the amount of charges created by the monoenergetic nuclear particle. The second one is the pulses pile-up due to the random nature of nuclear event and the finite duration of pulse and is represented by σ_2 . Third, σ_3 , the ballistic deficit arises when the pulse duration time is much shorter than the charge collection time in the detector. The last one is σ_4 which is the electronic noise, the major effect when the interesting signals are small. Therefore, the degree of degradation in energy resolution arising from the overall standard deviation can be written as follows:

$$\sigma^2 = \sigma_1^2 + \sigma_2^2 + \sigma_3^2 + \sigma_4^2 \quad (2.4)$$

or represented in term of FWHM values for each individual sources of fluctuation:

$$(\text{FWHM})_{\text{overall}}^2 = (\text{FWHM})_{\text{detector}}^2 + (\text{FWHM})_{\text{noise}}^2 + (\text{FWHM})_{\text{pile up}}^2 + (\text{FWHM})_{\text{ballistic deficit}}^2$$

Fig. 2.8, illustrates the energy degradation due to pulse height fluctuation. However, the optimum signal processing system would reduce the standard deviation to a minimum except the effect due to nature of detection process which depends on a detector-front-end system. The following section will describe the detail of the three factors that degrades the energy resolution in nuclear spectroscopy.

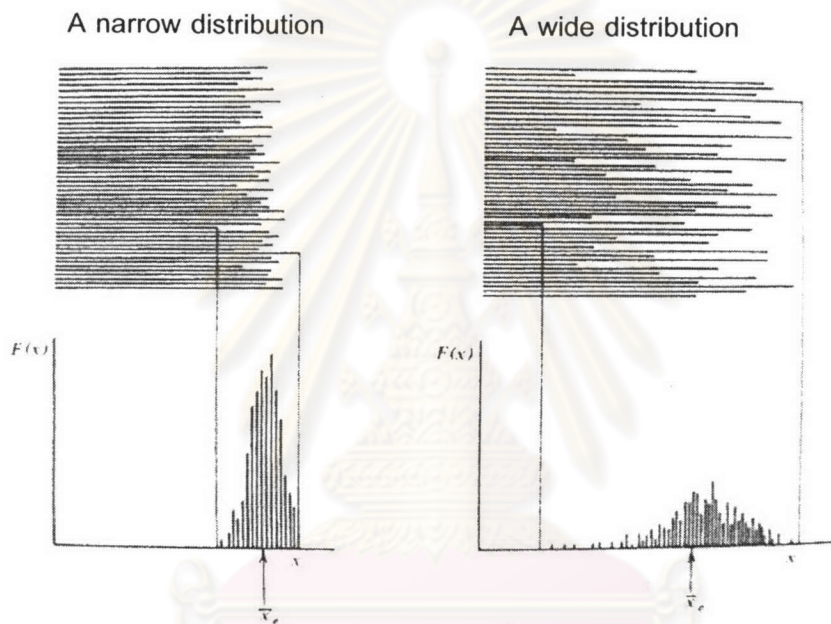

Fig. 2.8 Illustration of energy resolution degradation.

2.1.3 Noises in Nuclear spectrometer. Noise is a major contribution to energy resolution degradation in nuclear radiation spectroscopy as stated in published papers and well-known nuclear electronics textbooks. The detector amplifier system can be modeled in Fig. 2.9 relevant to effect on energy resolution.

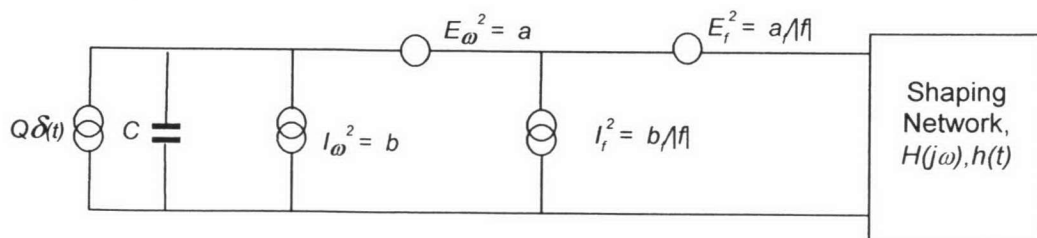

Fig. 2.9 Detector amplifiers modeled with noise sources.

Noise is assumed to arise from four uncorrelated sources at the input; E_{ω}^2 and I_{ω}^2 generate white voltage and current noise of spectral densities a and b respectively. E_f^2 and I_f^2 generate $1/f$ voltage and current noise of spectral density a/f and b/f respectively [12,13,14]. A global equivalent input current noise spectral densities is $N(\omega)$, and can be given as:

$$N(\omega) = C^2 a^2 + b + C^2 a_{\omega} |\omega| + b_{\omega} / |\omega| \quad (2.5)$$

where $2\pi a_f = a_{\omega}$ and $2\pi b_f = b_{\omega}$

Noise sources arise from detector leakage, detector bias resistor, preamplifier feedback resistor, resistor connected in series between detector and preamplifier, FET gate current, channel resistance of input FET, surface leakage and dielectric loss. Especially for high-energy nuclear spectroscopy, Lorentzian packet due to radiation damaged devices usually found. All of them can be found or derived from the knowledge of equivalent circuit and already known physical characteristic of devices and circuits in the mathematical form as previously stated. In addition, mathematical of input noise spectral density can be written in the form, which give information of physical characteristic and can be derived by established numerical technique for spectral identification [15,16].

$$N(\omega) = \sum_k H_k \frac{1}{1+G_k^2 \omega^2} + \frac{h_N}{|\omega|^N} + \dots + \frac{h_1}{|\omega|} + \frac{1}{1+F\omega + \omega^2 + k_1 |\omega|^3} + \dots + k_M |\omega|^{M+2} + \sum_K K_K \frac{L_k^2 \omega^2}{1+L_k^2 \omega^2} \quad (2.6)$$

All constants (H , h , G , L , K , k) are frequency independent, ω is an angular frequency. The relation between non-white noise and white noise is derived from corner angular frequency where white voltage noise spectrum crosses the non-white voltage spectrum and white current noise spectrum cross the non white current spectrum. The actual range is variable between a few Hz and 1 MHz according to the device and the operating conditions [11]. The corner frequency at which white voltage noise spectrum cross non-voltage noise spectrum is the noise corner time constant so that a reasonable duration for the pulse response can be made.

2.1.4 Pulse pile-up and Ballistic deficit

a) **Pulse pile-up.** Pulses pile up phenomenon is caused by the random nature of radiation emission. The time interval between two consecutive signals characterised by an exponential random distribution. The finite width of filtered signal will produce the distorted signal amplitude when the time interval between the consecutive pulses is too short. The high radiation emission rate introduces the more distorted signal amplitude resulting energy resolution degradation. as shown in Fig. 2.10

b) **Ballistic deficit.** The ballistic deficit arises from the longer time to collect charges induced by an ionizing radiation in radiation detector than the peaking time of filtered signal governed by filter inside the spectroscopy amplifier, as shown in Fig.2.11. The loss in pulse height at the output of spectroscopy amplifier is inconsistent if the fluctuation of charge collection time is great. Ballistic deficit variation can be a dominant contributor to the energy resolution of spectroscopy system under high counting rate conditions.

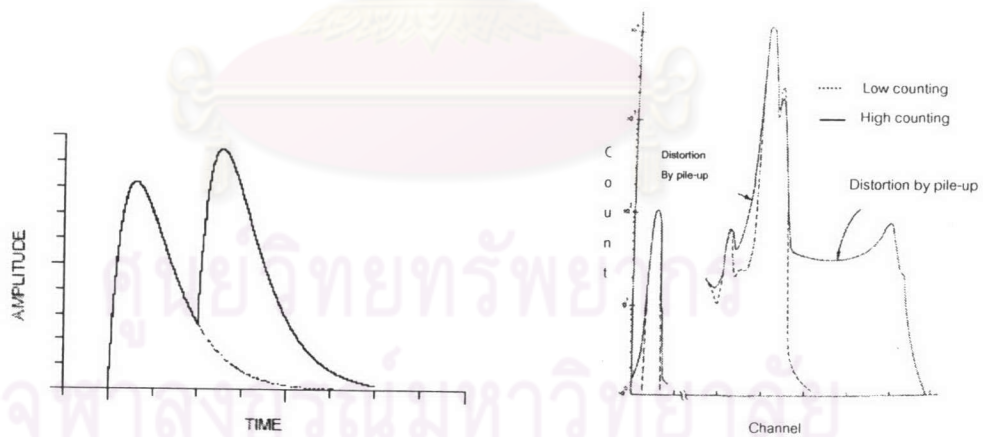

a) Pulse pile up

b) Spectrum distortion

Fig. 2.10 Illustration of energy spectrum distorted by pulse pile up.

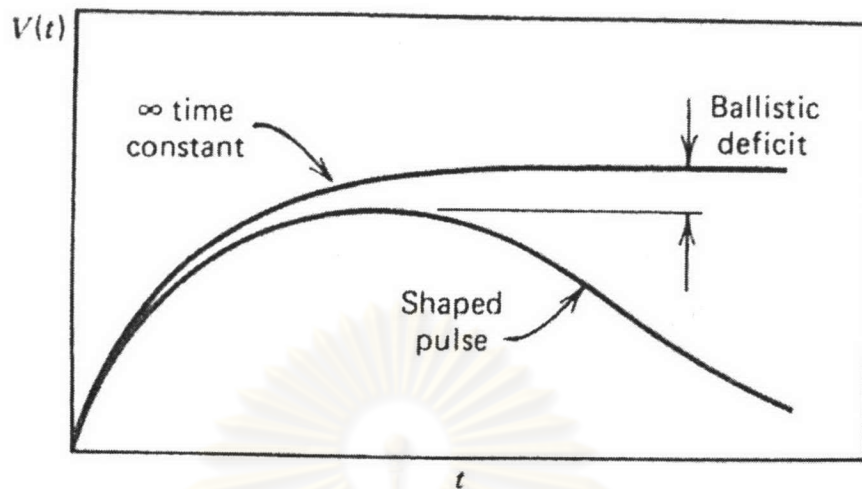

Fig. 2.11 Definition of the ballistic deficit

2.1.5 Pole zero compensation and Baseline restorer effect

a) **Pole zero compensation.** The pole-zero compensation circuit is provided to compensate the signal undershoot due to CR high pass at the first stage of signal processing chain. The basic pole-zero cancellation to eliminate the under shoot is shown in Fig. 2.12. In nuclear pulse analysis system, the pulse height is measured relative to a true zero base line. The presence of any over or undershoot will degrade energy resolution due to a variation of pulse height at same energy.

b) **Base line restorer.** The baseline restorer circuit has its function to restore the signal output from amplifier to zero baselines. Effect of baseline shift comes from the small DC component at the input to a high gain amplifier and gives rise to very large effect at the output. To eliminate the baselines shift in most high resolution spectroscopy system, the active baselines restorer is employed.

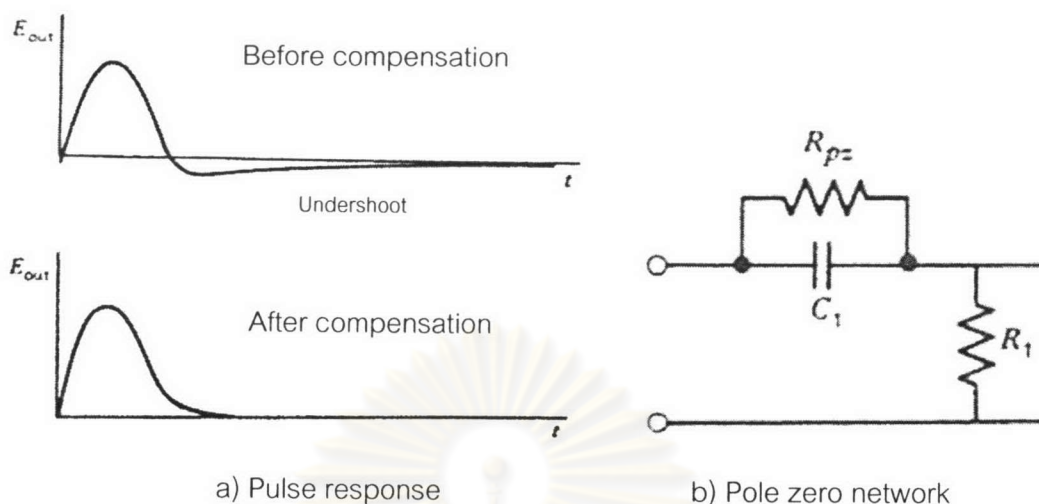

Fig. 2.12 Pole zero cancellation to eliminate the undershoot.

2.2 Optimization of signal to noise ratio

2.2.1 Signal to noise ratio. It is assumed that the overall FWHM is due solely to the noise contribution, the effects of pulse pile-up and ballistic deficit variations being neglected. The output signal in the absence of noise will be the pulse having a constant height V . If the noise at the output has a voltage V_n at any time the signal pulse will superimposed by this noise voltage to give a resultant pulse height $(v)=V+V_n$ as in Fig. 2.13

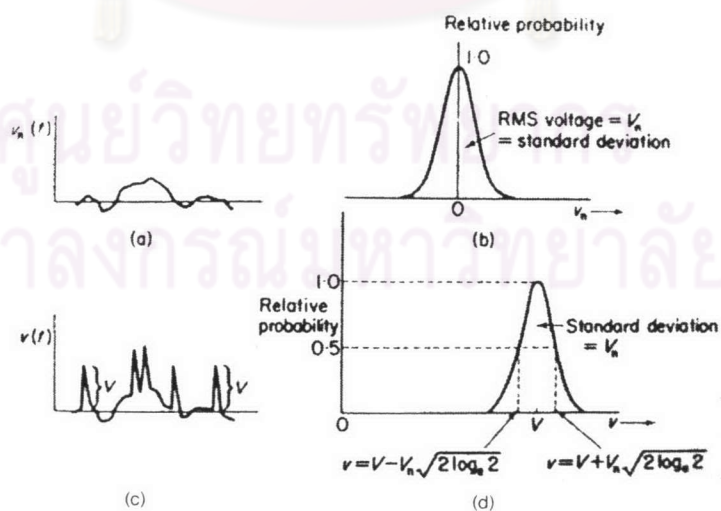

Fig. 2.13 Illustration of signal and noise in spectroscopy (a) Noise voltage only (b) Probability distribution of noise voltage (V_n) (c) Noise voltage plus pulses of constant height (V) (d) The probability distribution of pulse height ($V+V_n$)

The signal to noise ratio, η , is defined as the ratio of the mean signal pulse height V to the root mean square (RMS) noise voltage V_n . This leads to the following relation.

$$\frac{V_{FWHM}}{V} = \frac{E_{FWHM}}{E} = 2.35 \frac{V_n}{V} = \frac{2.35}{\eta} \quad (2.7)$$

The signal to noise ratio in a given system depends on both the magnitude of noise and also on the signal pulse magnitude and hence on the energy of nuclear particles being detected. For a figure of merit of energy resolution in a system which is independent of the energy of the nuclear particles, it is possible to use E_{FWHM}

2.2.2 Power spectral density of noise. All of the noise sequences can be assumed to be the realization of ergodic, stationary, discrete-time random processes. The sample-to-sample correlation of such a process can be characterized by the time-averaged autocorrelation over any one of the realizations of the process. Therefore, the power spectral density (PSD) is the discrete-time Fourier transform of the autocorrelation, $R_x[k]$ and can be given as [17]:

$$R_x[k] = \lim_{M \rightarrow \infty} \frac{1}{2M+1} \sum_{n=-M}^M x[n]x^*[n-k] \quad (2.8)$$

Where $x[n]$ is samples, M is a number of $x[n]$. and the Power Spectral Density $S_x(f)$ is

$$S_x(f) = \sum_{k=-\infty}^{\infty} R_x[k] \exp(-j2\pi fkT) \quad (2.9)$$

Generally, equivalent noise charge (ENC) [18] is the parameter that represents the contribution of noise to the total system. The value of ENC is usually expressed in unit of electrons so it can be readily compared to a signal charge generated in the detector. In time domain, the ENC value of any noise component can be calculated from output noise waveforms by dividing the root-mean-square of noise voltage to the amplitude of signal pulse generated by a single electron at the shaper output. In frequency domain, ENC of particular noise sources can be calculated if noise power spectral density function and shaping network transfer function are already known. The power spectral density of noise is shown in Fig. 2.14.

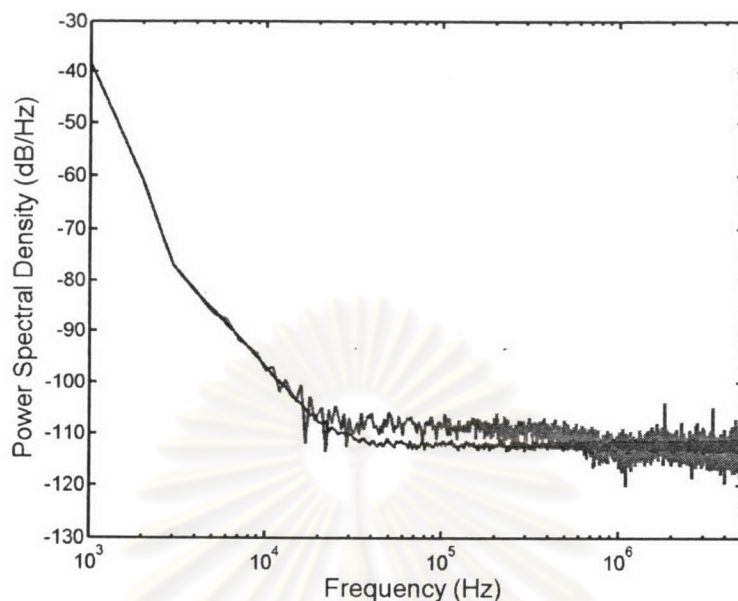

Fig. 2.14 Power spectral density of noise

2.2.3 Power transfer function of spectroscopy amplifier

2.2.3.1 Linear time-invariant systems. A linear-Time-Invariant (LTI) system is one where a time delay (or shift) in the input sequence causes an equivalent time delay in the system's output sequence. Assume that n is just an indexing variable which use to keep track of system input and output samples. If a system provides an output $y(n)$ given an input of $x(n)$, or

$$x(n) \xrightarrow{\text{result in}} y(n)$$

For a system to be time invariant, with a shifted version of the original $x(n)$ input applied, $x'(n)$, the following applies:

$$x'(n)=x(n+k) \xrightarrow{\text{result in}} y'(n)=y(n+k)$$

Where k is some integer representing k sample period of time delays.

LTI systems have a useful commutative property by which their sequential order can be rearranged with no change in their final output. This situation is shown in Fig. 2.15, where two-different LTI systems dose not alter the final output. Although the intermediate data sequences $f(n)$ and $g(n)$ will usually not be equal, the two pairs of LTI systems will have identical $y(n)$ output sequences.

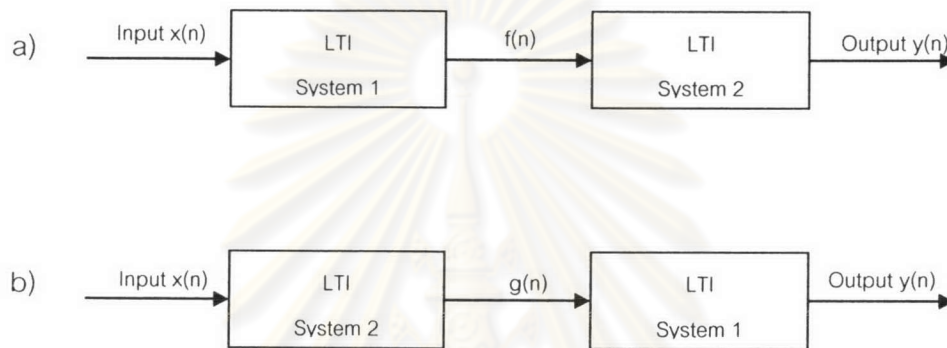

Fig. 2.15 Linear time-invariant systems in series. a) Block diagram of two LTI systems

b) swapping the order of the two-systems dose not change the resultant output $y(n)$.

2.2.3.2 Spectroscopy amplifier as a linear time-invariant model.

The nuclear spectroscopy amplifier consists of three major parts or sub system i.e. Pole-zero compensation, Band pass filter and Base line restorer. They are formed to be a complex model and can be defined as a linear time-invariant model, which can be described by its transfer function or by the frequency response. The function can be defined by direct techniques without first selecting a confined set of possible models. This method is called nonparametric since they do not employ a finite dimensional parameter for the best description. The frequency response of nuclear spectroscopy amplifier is determined from the relation of input to output in time domain. The frequency response is not represented by equations but represented by arrays of numbers at each resultant frequency called arbitrary frequency response.

2.2.3.3 Frequency Response Function. If $x(n)$ and $y(n)$ are input and output signals of linear time invariant system characterized by the impulse response $h(n)$, then $y(n)$ is resulted from convolution of $x(n)$ and $h(n)$, as shown in Fig. 2.16 The impulse response, in principle, can be computed through the deconvolution operation. However, deconvolution is not always computationally feasible, if the input and output processes are jointly stationary.

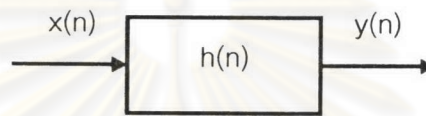

Fig. 2.16 Input-output linear time invariant system model. Where $x(n)$ and $y(n)$, are input ideal response and output measurement respectively.

The discrete Fourier transform (DFT) of the convolution of a linear-time-variant system's impulse response and an input sequence is equal to the product of the spectrum of the input sequence and the DFT of the impulse response. If two time domain sequences $h(n)$ and $x(n)$ have DFTs of $H(e^{j\omega})$ and $R_x(e^{j\omega})$ respectively, the frequency response, $H(e^{j\omega})$, can be obtained from the Fourier transform of cross correlation between these two processes and the relationship can be stated as follows:

$$y(n) = h(n) * x(n) \begin{matrix} \xrightarrow{DFT} \\ \xleftarrow{IDFT} \end{matrix} H(e^{j\omega}) \cdot R_x(e^{j\omega}) \quad (2.10)$$

$$H(e^{j\omega}) = \frac{R_{yx}(e^{j\omega})}{R_x(e^{j\omega})} \quad (2.11)$$

Where R_{yx} and R_x are Fourier transforms of cross correlation and input.

2.2.4 Dependence of noise on shaping time. The importance of various source of electronic noise in the measured signal to noise ratio depends on choices of parameters used in the filtering or wave shaping operation. One of the important choices presented to the routine use in nuclear spectroscopy amplifier is a wide range of

possible shaping time. The optimum shaping time will generally occur at the point where the series and parallel noise contribution are equal. As illustrated in Fig. 2.17, the contribution of series noise tends to become less significant if shaping time is increased. On the other hand, sources of parallel noise become more significant. There is another category of noise that includes i.e., effect of charge motion in detector or semiconductor devices. The $1/f$ noise does not change with choice of the shaping time.

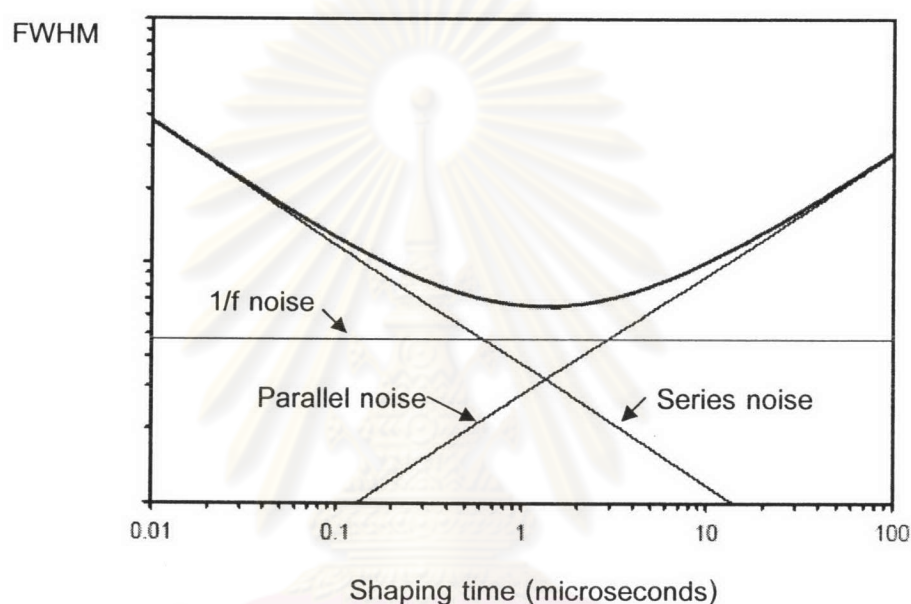

Fig. 2.17 The contribution of series, parallel and $1/f$ noise to FWHM and shaping time.

Besides effect from pulse pile-up at high count rate is also dependent on the shaping time. It is an important procedure that user must carry out an optimum shaping time searching as a post activity after the individual set up of the detector system in order to the best energy resolution.

2.3 Literature review

2.3.1 Factors of energy resolution degradation.

Radiation detector, which converts the detected photon energies of radiation into electrical charges and forms the electrical signal, is the major factor effecting energy resolution of nuclear spectroscopy system. The discrete numbers of charges depend on the conversion factor or mean particle energy per ion pair which is subject to the statistical fluctuations

causing energy resolution degradation. Radiation induced damage is also one problem in energy resolution degradation. Ethan L. Hull, Richard H. Pehl, Craig Tindall, Paul N. Luke and James D. Kurfess [19] study the effects of radiation damage caused by 200 MeV protons on charge collection effects in Si (Li) gamma-ray detector to determine the validity of operation in space. The result exhibits slight energy resolution degradation and no other radiation damage effects are observed.

Preamplifier is the first element in a signal processing chain. It serves as an interface between the radiation detector and the pulse processing portion including the pulse height analyzer. Noises from preamplifier arise from the input capacitance, a connected detector, HV bias, and connecting cable, so the cable length must be kept as short as possible to reduce noise effect. In practice, preamplifier should be tested following IEEE STD 301-1976, standard test procedure for amplifiers and preamplifiers for semiconductor radiation detectors for ionizing radiation, to ensure the optimum energy resolution of the system being obtained. Nowadays, the circuit of charge sensitive preamplifier is changed from RC type to active reset preamplifier to prevent the overload recovery and pile-up that degrade the energy resolution as shown in Fig. 2.18. At present energy resolution degradation from electrical noises from preamplifier electronic devices becomes a major concern under studies.

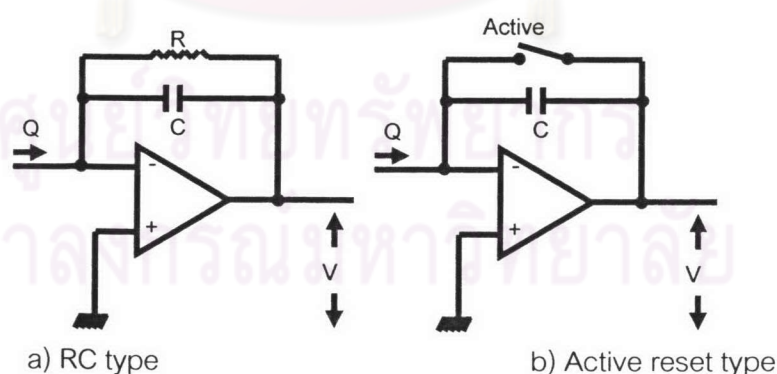

Fig. 2.18 Charge sensitive preamplifier circuits.

CMOS front end systems have been developed to acquire and process signals from pixel detectors in broad area detector. CMOS is a major source of $1/f$ noise related to gate-oxide thickness. P.F. Manfredi, M. Manghisoni, L.Ratti, V. Re and V. Speziali [20] investigate the two different process of MOSFET in noise characteristic.

The reduction in channel length and gate oxide thickness techniques can reduce $1/f$ and thermal noise that are the cause of energy resolution degradation. Preamplifier kept close to detector may be damaged by radiation. Werner Buttler, Bedrich J. and Hosticka [21] show the radiation resistance testing for preamplifier. The preamplifier was exposed by 150 krad of Gamma ray emitted by Co-60. The result shows no significant increase of equivalent noise source.

Spectroscopy amplifier receives signal from preamplifier. The main function of amplifier is to shape the signal pulse, reduces noise and gains the maximum signal to noise ratio. The relation between noise performance and signal shaping technique is known as noise index, which was presented by F.S. Goulding [1]. He presented the analysis technique of the relative noise performance of pulse shaping systems. This technique is simple and directly connects to physical process. Noise performances of time variant and invariant systems are illustrated by the technique.

Optimum filter is the best filter for evaluating the charge released by the radiation detector in the presence of various noise spectral densities also featuring a pulse response subject to various constraints. Alberto Pullia [16] presented the method for calculating the optimum filter for high resolution nuclear spectroscopy with time domain constraints and in presence of any kind of noises. The method can be set-up in computer as a tool for optimizing a digital signal processing spectroscopy in digital filter section.

In many experimental setups the unwanted disturbance occurs in the system and deteriorates energy resolution, where noise reduction can be achieved through shielding, careful design and employment of other noise reduction techniques. However, energy resolution is not sufficiently immune to the unwanted periodic disturbance. Angelo Geraci and Emilio Gatti [17] presented the method capable of eliminating the unwanted periodic disturbances occurring in high resolution spectroscopy while still minimizing the effect of electronic noise which is the new class of optimum filter.

The nature and magnitude of noise in presence of detector signal and time interval between signal pulses in spectroscopy system or pile-up effect can be

used as the starting point for the choice of shaping method which trades between high energy resolution and high count rate. G.P. Westphal, K. Jostl, P. Schroder and W. Winkelbauer [18] presented the method of adaptive digital filter, which automatically adapts its noise filtering time to the pulse intervals occurring and matched to the system's noise corner time constant.

2.3.2 Nuclear spectroscopy simulation. P.J.M.B. Rachinhas, T.H.V.T. Dias, F.P. Santos, A.D. Stauffer and C.A.N. Conde [24] compare multiplication factor and energy resolution in xenon filled cylindrical proportional counters by the detailed Monte Carlo simulation model and experiments. The results of simulation show very good predictions for the multiplication factor and energy resolution. R.P. Gardner and S.H. Lee [25] have developed the Monte Carlo simulation code CEARPPU to simulate pulse pile-up for high counting rates from true spectrum. The simulation results show excellent agreement with measurements with a Fe-55 source and a Si(Li) detector. E. Karvelas , D. Loukas, A. Markou and A.H. Walenta [26] present the Monte Carlo simulation of pile-up effect in x-ray detection with large area circular silicon drifted detectors. The correlation of incoming x-ray flux, detector area, signal induced on sensing electrode and front end analog electronics response function having strong influence on the counting capability of a detector have been taken into account in simulation. The results show the behavior of detector counting capability and pile-up efficiencies. M. Brigida, C. Favuzzi, P. Fusco, F. Gargano, N. Giglietto, F. Giordano, F. Loparco, B. Marangelli, M.N. Mazziotta, N. Mirizzi, S. Raino and P. Spinelli [27] developed a full simulation code to evaluate the response of silicon strip detectors. The physical processes leading to generation of signal like induced current, electronic noise and readout electronics have been taken into account. This simulation can be applied in the design stage of silicon strip detector when the parameters have been chosen in order to optimize its performance. Alberto Pullia et al. [5] conducted the method aimed at determining the minimum noise filter to real system as shown in Fig. 2.19. A prerequisite for a proper design of such a digital processor is an adequate knowledge of the overall input noise, because its spectral characteristics, along with those of the signal itself, dictate the shape of the minimum noise filter. The experiment consists of noise spectral density and

minimum noise filter determination. Noise spectral density derived from a sequence of noise samples from preamplifier output passes along to the personal computer for the calculation of the correlation function and computation of the corresponding its Discrete Fourier Transform (DFT). Then the minimum noise filter is determined by mean of published algorithm. This study shows the possibility to gain the knowledge on global noise in real nuclear spectroscopy with the simple DSP techniques that can be found in general signal-processing textbooks.

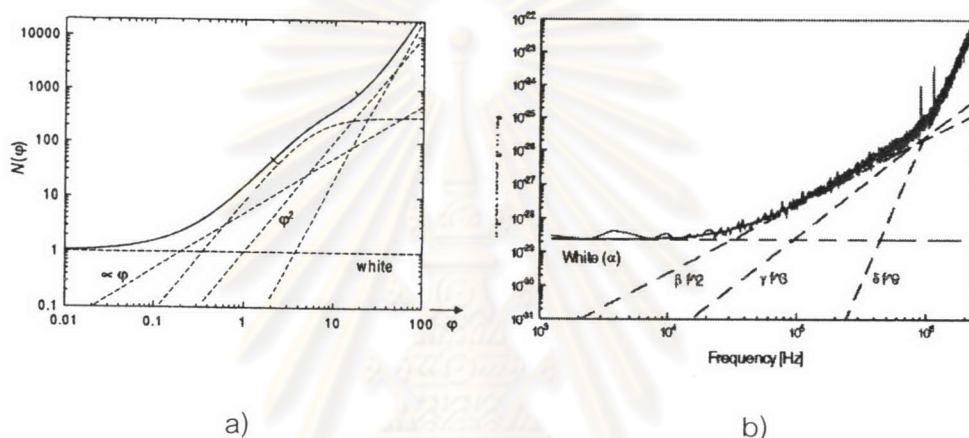

Fig. 2.19 Noise Power Spectral Density derived from sample of preamplifier.

a) Show sub PSD of Overall PSD b) Show fitting parameter.

Kuwata and R.Isobe [28] proposed a modeled noise using computer program named SPICE which is responsive to the real system in computation of $1/f$, step and delta noise indices of the linear and time-variant filter like triangular and trapezoidal shaping function in case of the x-ray spectrometer that the major noise components are $1/f$. Tae-Hoon Lee and Gyueong Cho [29] presented a time domain Monte Carlo based Hspice noise simulation of a charge-sensitive preamplifier in conjunction with CR-RC wave shaping circuit to generate the random amplitude noise wave form. The amplitude distribution of thermal and $1/f$ noise are modeled and the noise sources are arranged in form of noise produced waveform, referred to the noise from preamplifier output. Alberto Pullia and Stefano Riboldi [30] proposed a computer simulation procedure for generating the electronic noise of ionizing-radiation spectrometers in time domain. The electronic noise is generated from fundamental electrical-physical parameter of the system including: detector capacitance, detector leakage current, feedback resistor, $1/f$ -

noise coefficient of the input transistor and temperature of the preamplifier input devices. This simulation is benefit to study a new generation of cylindrical HPGe detector. The method can be illustrated in three-dimensional (3D) co-ordinates of the interaction points of the gamma photons inside the detector. The sophisticated algorithms of pulse shape analysis (PSA) can be tested by this simulation. These features of the research work come to fill the gap of former simulation method.

2.3.3 Summary of research work. The enhancement of energy resolution in nuclear spectroscopy system design is a subject on spectrometer components development almost. In user's view, only the standard procedures of IEEE can be used to approve the improper system set-up for enhancing energy resolution. Owing to the unsuitable spectroscopy amplifier shaping time constant setting, the energy resolution of system may be three times decreased. There are no developed methods or instruments supporting the traditional nuclear spectrometer for searching the best shaping time.

From literature review, the nuclear spectroscopy system simulation shows the good agreement between simulation and experiment. The sophistication of radiation induced signal simulation algorithms depends on detector model usage in either works whether all parameters of the system can be inputted. In this research, the radiation signal simulation is simplified by replacing the general model of signal produced by preamplifier, including electronic noises which are the major problem in low energy spectroscopy system with the theoretical noise model cited in Brigida's work. Consequently, the near signal output from the front-end system can be simulated.

According to some results of previous works, the signal processing method that enhances the energy resolution in nuclear spectroscopy by searching the optimum shaping time constant that trades between high energy resolution and high count rate can be performed in time domain simulation. The influencing parameters in real system have to be measured and modeled. The behavior of signals passing through the signal processing chain is simulated and used in evaluating the optimum shaping time constant.

This work aims to develop the signal processing method that enhances the energy resolution in nuclear spectroscopy following the procedure mentioned earlier. This method will be helpful to the nuclear spectroscopy users in the field of radiation detection and measurement using the traditional spectrometers. Detail study for a better understanding of nuclear spectroscopy system operation has been integrated with a variety of theoretical techniques to investigate their characteristics. The techniques rely on models based simulation, not only on the spectrometer itself but also its associated parts and radiation characteristics like detector, noise and pile-up phenomenon. The success will be of benefits to nuclear spectroscopists and nuclear researchers in low energy radiation detection as well as the development of digital signal processing in the field of nuclear electronics and nuclear instrumentation.



ศูนย์วิทยทรัพยากร
จุฬาลงกรณ์มหาวิทยาลัย