

ผลของตัวรองรับที่ได้โดยโซลเจลที่มีต่อรีฟอร์มมิ่งของมีเทนด้วยคาร์บอนไดออกไซด์บนตัวเร่ง
ปฏิกิริยานิกเกิลบนตัวรองรับ

นางสาวนิตา ทัพหกิจ

วิทยานิพนธ์นี้เป็นส่วนหนึ่งของการศึกษาตามหลักสูตรปริญญาวิทยาศาสตรมหาบัณฑิต
สาขาวิชาวิศวกรรมเคมี ภาควิชาวิศวกรรมเคมี
คณะวิศวกรรมศาสตร์ จุฬาลงกรณ์มหาวิทยาลัย
ปีการศึกษา 2554
ลิขสิทธิ์ของจุฬาลงกรณ์มหาวิทยาลัย

บทคัดย่อและแฟ้มข้อมูลฉบับเต็มของวิทยานิพนธ์ตั้งแต่ปีการศึกษา 2554 ที่ให้บริการในคลังปัญญาจุฬาฯ (CUIR)
เป็นแฟ้มข้อมูลของนิสิตเจ้าของวิทยานิพนธ์ที่ส่งผ่านทางบัณฑิตวิทยาลัย

The abstract and full text of theses from the academic year 2011 in Chulalongkorn University Intellectual Repository (CUIR)
are the thesis authors' files submitted through the Graduate School.

EFFECT OF SOL-GEL DERIVED SUPPORTS ON CO₂ REFORMING REACTION
OF METHANE OVER SUPPORTED NICKEL CATALYSTS

Miss Wanida Tanhakit

A Thesis Submitted in Partial Fulfillment of the Requirements
for the Degree of Master of Engineering Program in Chemical Engineering

Department of Chemical Engineering

Faculty of Engineering

Chulalongkorn University

Academic Year 2011

Copyright of Chulalongkorn University

Thesis Title EFFECT OF SOL-GEL DERIVED SUPPORTS ON
CO₂ REFORMING REACTION OF METHANE
OVER SUPPORTED NICKEL CATALYSTS

By Miss Wanida Tanhakit

Field of Study Chemical Engineering

Thesis Advisor Assistant Professor Suphot Phatanasri, Ph.D.

Accepted by the Faculty of Engineering, Chulalongkorn University in Partial
Fulfillment of the Requirements for the Master's Degree

.....Dean of the Faculty of Engineering
(Associate Professor Boonsom Lerdhirunwong, Dr. Ing.)

THESIS COMMITTEE

.....Chairman
(Assistant Professor Montree Wongsri, D.Sc.)

.....Thesis Advisor
(Assistant Professor Suphot Phatanasri, Ph.D.)

.....Examiner
(Associate Professor Joongjai Panpranot, Ph.D.)

.....External Examiner
(Soipatta Soisuwan, D.Eng.)

วนิดา ทัพหกิจ : ผลของตัวรองรับที่ได้โดยโซลเจลที่มีต่อรีฟอร์มมิ่งของมีเทนด้วยคาร์บอนไดออกไซด์บนตัวเร่งปฏิกิริยานิกเกิลบนตัวรองรับ. (EFFECT OF SOL-GEL DERIVED SUPPORTS ON CO₂ REFORMING REACTION OF METHANE OVER SUPPORTED NICKEL CATALYSTS) อ.ที่ปรึกษาวิทยานิพนธ์หลัก: ผศ.ดร.สุพจน์ พัฒนะศรี, 64 หน้า.

การศึกษาผลของตัวรองรับที่ได้โดยโซลเจลที่มีต่อรีฟอร์มมิ่งของมีเทนด้วยคาร์บอนไดออกไซด์บนตัวเร่งปฏิกิริยานิกเกิลบนตัวรองรับที่มีต่อความว่องไวในการเกิดปฏิกิริยาและค่าการเลือกเกิดของผลิตภัณฑ์ ได้แก่ไฮโดรเจนและคาร์บอนมอนอกไซด์ โดยมีชนิดของตัวรองรับที่มีความแตกต่างของวิธีการเตรียมได้แก่วิธีโซลเจลและวิธีโซลโวกเทอร์มอล ความแตกต่างของเฟสอะลูมินา และความแตกต่างของสารตั้งต้นในการเตรียมโซลเจลอะลูมินา การทดลองกระบวนการรีฟอร์มมิ่งของมีเทนด้วยคาร์บอนไดออกไซด์บนตัวเร่งปฏิกิริยานิกเกิลบนตัวรองรับถูกดำเนินการที่สภาวะอุณหภูมิ 700 องศาเซลเซียส ณ ความดันบรรยากาศ ผลการทดลองพบว่าตัวเร่งปฏิกิริยานิกเกิลบนตัวรองรับที่เตรียมโดยวิธีโซลเจลโดยใช้สารตั้งต้นอะลูมิเนียมไฮดรอกไซด์ และ ตัวเร่งปฏิกิริยานิกเกิลบนตัวรองรับที่เตรียมโดยวิธีโซลโวกเทอร์มอลชนิดเฟสผสม 50% χ อะลูมินาและ γ อะลูมินา และจะแสดงค่าร้อยละการเปลี่ยนแปลงของมีเทนสูงกว่าตัวเร่งปฏิกิริยาอื่นๆ คือ ร้อยละ 87 และ ร้อยละ 85.5ตามลำดับ นอกจากนี้ยังมีการศึกษาผลจากการเติมน้ำเข้าไปในกระบวนการรีฟอร์มมิ่งของมีเทนด้วยคาร์บอนไดออกไซด์ที่มีผลต่อค่าร้อยละการเปลี่ยนแปลงของสารตั้งต้นในระยะเวลา 6 ชั่วโมง ผลการทดลองพบว่าร้อยละการเปลี่ยนแปลงของมีเทนในกระบวนการรีฟอร์มมิ่งของมีเทนด้วยคาร์บอนไดออกไซด์บนตัวเร่งปฏิกิริยานิกเกิลบนตัวรองรับที่เติมน้ำในสายป้อนมีค่ามากกว่ากระบวนการรีฟอร์มมิ่งของมีเทนด้วยคาร์บอนไดออกไซด์บนตัวเร่งปฏิกิริยานิกเกิลบนตัวรองรับที่ไม่มีการเติมน้ำในสายป้อน

ภาควิชา.....วิศวกรรมเคมี.....ลายมือชื่อนิสิต.....
 สาขาวิชา.....วิศวกรรมเคมี.....ลายมือชื่อ อ.ที่ปรึกษาวิทยานิพนธ์หลัก.....
 ปีการศึกษา.....2554.....

#5370483621 : MAJOR CHEMICAL ENGINEERING

KEYWORDS: CARBON DIOXIDE REFORMING/ALUMINA/NICKEL/SOL-GEL/SOLVOTHERMAL/PHASE ALUMINA

WANIDA TANHAKIT: EFFECT OF SOL-GEL DERIVED SUPPORTS ON CO₂ REFORMING REACTION OF METHANE OVER SUPPORTED NICKEL CATALYSTS. ADVISOR: ASST.PROF.SUPHOT PHATANASRI, Ph.D., 64 pp.

Effect of sol-gel derived supports on CO₂ reforming reaction of methane over supported nickel catalysts was studied as well as the effect of different types of supports, prepared by sol-gel method and solvothermal method, different phase of alumina and amount of metal loaded on catalysts. It had been found that 7% Ni/ γ -Al₂O₃ (AIP,solgel) and 50% γ - χ -Al₂O₃ (AIP,solvothermal) had the highest conversion of 87% and 85.5%, respectively with the highest coke resistance of all the catalysts studied in CO₂ reforming reaction of methane at 700 °C and 1 atm. In addition, the effect of addition of water into feed steam had also observed and found the slightly conversion increase with the water addition during the 6 hours on stream of reaction.

Department : Chemical Engineering Student's Signature

Field of Study : Chemical Engineering Advisor's Signature

Academic Year : 2011

ACKNOWLEDGEMENTS

The author would like to express her greatest thankfulness and appreciation to her advisor, Assistant Professor Dr. Suphot Phatanasri. For his instruction and value suggestions throughout this study.

Special thanks for kind suggestions and useful help to Miss Rudemas Manosak, Miss Kietlada Warinsirirux and many friends in Center of Excellence on Catalysis and Catalytic Reaction Engineering who always provide the encouragement and co-operate along the thesis study. And she also very thanks for special suggestion to Miss Nuchchanok Yoonpan.

Finally, she would like to dedicate the achievement of this work to her parents (Mrs. Wannee anf Mr.Anon Tanhakit) and her uncle (Mr.Amnuay Nakratchata-amorn) who have always been the source of her suggestion, support and encouragement.

CONTENTS

| | Page |
|---|------|
| ABSTRACT IN THAI..... | iv |
| ABSTRACT IN ENGLISH..... | v |
| ACKNOWLEDGEMENTS..... | vi |
| CONTENTS..... | vii |
| LIST OF TABLES..... | ix |
| LIST OF FIGURES..... | x |
| CHAPTER I INTRODUCTION..... | 1 |
| CHAPTER II THEORY..... | 4 |
| 2.1 Synthesis gas and hydrogen production..... | 4 |
| 2.2 Reforming reaction of methane by carbon dioxide..... | 5 |
| 2.3 Supported catalyst and Metal catalyst..... | 8 |
| CHAPTER III LITERATURE REVIEW..... | 12 |
| CHAPTER IV EXPERIMENTAL..... | 16 |
| 4.1 Catalyst preparation..... | 16 |
| 4.1.1 Preparation of various phase of alumina supports by solvothermal..... | 17 |
| 4.1.2 Preparation of alumina supports from various precursor by sol-gel..... | 18 |
| 4.1.3 Nickel loading on supports..... | 18 |
| 4.2 Catalyst characterization..... | 18 |
| 4.2.1 X-ray diffraction (XRD)..... | 18 |
| 4.2.2 Nitrogen physisorption..... | 19 |
| 4.2.3 NH ₃ Temperature Programmed Desorption (NH ₃ -TPD)..... | 19 |
| 4.2.4 N ₂ adsorption-desorption isotherm..... | 19 |
| 4.2.5 Scanning Electron Microscopy (SEM)..... | 19 |
| 4.2.6 CO Chemisorption..... | 19 |
| 4.2.7 Thermogravimetric and differential thermal analysis (TG-DTA)..... | 20 |
| 4.3 Reaction Activity..... | 20 |
| 4.3.1 Chemicals and Reagents..... | 20 |

| | Page |
|--|------|
| 4.3.2 Instrument and Apparatus..... | 20 |
| 4.3.3 Reaction method..... | 21 |
| CHAPTER V RESULTS AND DISCUSSION..... | 24 |
| 5.1 The effect phase of alumina supported nickel catalyst on catalytic activity..... | 24 |
| 5.1.1 Characterization of catalyst..... | 24 |
| 5.1.1.1 X-Ray Diffraction..... | 24 |
| 5.1.1.2 Nitrogen physisorption..... | 26 |
| 5.1.1.3 Ammonia Temperature Programmed Desorption (NH ₃ -TPD)..... | 27 |
| 5.1.1.4 CO-chemisorption..... | 29 |
| 5.1.2 Reaction study of commercial γ -Al ₂ O ₃ and synthetic Al ₂ O ₃ supported Nickel catalysts..... | 30 |
| 5.1.2.1 Reaction study of commercial γ -Al ₂ O ₃ and synthetic Al ₂ O ₃ supported Nickel catalysts..... | 30 |
| 5.1.2.2 Reaction study of amount of Nickel supported on catalysts.... | 38 |
| 5.1.2.3 Reaction study of additional of water in feed..... | 41 |
| 5.1.3 Morphology..... | 42 |
| 5.1.4 Amount of coke..... | 50 |
| CHAPTER VI CONCLUSIONS AND RECOMMENDATIONS..... | 51 |
| REFERENCES..... | 52 |
| APPENDICES..... | 54 |
| Appendix A Calculation of reaction flow rate..... | 55 |
| Appendix B Calibration curves..... | 56 |
| Appendix C Calculation for metal active sites and dispersion..... | 59 |
| Appendix D Data of calculation of acid site..... | 60 |
| Appendix E Calibration curve of chi phase percent..... | 62 |
| Appendix F List of publication..... | 63 |
| VITA..... | 64 |

LIST OF TABLES

| TABLE | Page |
|---|-------------|
| 2.1 Physical and structural characteristic of common aluminum oxides..... | 9 |
| 3.1 χ/γ ratio in preparing catalysts of solvothermal method..... | 17 |
| 3.2 Operating condition gas chromatograph for CH ₄ /CO ₂ to syngas..... | 21 |
| 5.1 BET surface area of Nickel supported on alumina catalysts..... | 26 |
| 5.2 Acidity of synthetic alumina supported..... | 28 |
| 5.4 Amount of carbon monoxide adsorbed on catalysts..... | 29 |

LIST OF FIGURES

| FIGURE | Page |
|--|-------------|
| 2.1 A model for CO ₂ reforming of CH ₄ over a Pt/ZrO ₂ catalyst..... | 7 |
| 2.2 Alumina phases present in different temperatures: (a) corresponds to the path favored for fine crystals, (b) to the path for moist or particles..... | 9 |
| 3.1 Scheme diagram of reforming reaction of methane by CO ₂ | 22 |
| 5.1 XRD patterns of synthetic mixed phase of alumina (Ni/C100G0, Ni/C50G50, Ni/C0G100) and the commercial γ -Al ₂ O ₃ | 24 |
| 5.2 XRD patterns of 7% Ni- alumina in any preparation and precursor (Ni/Solvothermal,AIP, Ni/Sol-gel.Al(NO ₃) ₃ , Ni/Sol-gel,AIP)..... | 25 |
| 5.3 XRD patterns of 7% Ni/ γ -alumina which prepared by sol-gel..... | 25 |
| 5.4 The NH ₃ -TPD profile of synthetic alumina supported 7%wt of Nickel.... | 27 |
| 5.4 The effect of supported-nickel catalyst on the conversion of CH ₄ | 30 |
| 5.5 The effect of supported-nickel catalyst on the conversion of CO ₂ | 31 |
| 5.8 The effect of supported-nickel catalyst on the Selective of CO..... | 31 |
| 5.9 The effect of supported-nickel catalyst on the Selective of H ₂ | 32 |
| 5. 10 The effect of supported-nickel catalyst on the conversion of CH ₄ | 33 |
| 5.11 The effect of supported-nickel catalyst on the conversion of CO ₂ | 33 |
| 5. 12 The effect of supported-nickel catalyst on the Selective of CO..... | 34 |
| 5. 13 The effect of supported-nickel catalyst on the Selective of H ₂ | 34 |
| 5. 14 The effect of supported-nickel catalyst on the conversion of CH ₄ | 35 |
| 5. 15 The effect of supported-nickel catalyst on the conversion of CO ₂ | 36 |
| 5. 16 The effect of supported-nickel catalyst on the Selective of H ₂ | 37 |
| 5. 17 The effect of supported-nickel catalyst on the Selective of CO..... | 37 |
| 5.18 The effect of amount of nickel on catalyst on the conversion of CH ₄ | 38 |
| 5.19 The effect of amount of nickel on catalyst on the conversion of CO ₂ | 39 |
| 5.20 The effect of amount of nickel on catalyst on the selective of H ₂ | 39 |

| FIGURE | Page |
|--|-------------|
| 5.21 The effect of amount of nickel on catalyst on the selective of CO..... | 40 |
| 5.22 The effect of additional of water on the conversion of CH ₄ | 31 |
| 5.23 The SEM images of fresh 7%Ni/γ-Al ₂ O ₃ (commercial)..... | 42 |
| 5.24 The SEM images of fresh 7%Ni/γ-Al ₂ O ₃ (AIP,solvothermal)..... | 43 |
| 5.25 The SEM images of fresh 7%Ni/γ-Al ₂ O ₃ (AIN,solgel)..... | 43 |
| 5.26 The SEM images of fresh 7%Ni/χ-Al ₂ O ₃ (AIP,solvothermal)..... | 44 |
| 5.27 The SEM images of fresh 5%Ni/γ-Al ₂ O ₃ (AIP,solgel)..... | 44 |
| 5.28 The SEM images of fresh 7%Ni/γ-Al ₂ O ₃ (AIP,solgel)..... | 45 |
| 5.29 The SEM images of fresh 10%Ni/γ-Al ₂ O ₃ (AIP,solgel)..... | 45 |
| 5.30 The SEM images of fresh 7%Ni/50%γ-χ-Al ₂ O ₃ (AIP,solvothermal)..... | 46 |
| 5.31 The SEM images of used 7%Ni/γ-Al ₂ O ₃ (commercial)..... | 46 |
| 5.32 The SEM images of used 7%Ni/50%γ-χ-Al ₂ O ₃ (AIP,solvothermal)..... | 47 |
| 5.33 The SEM images of used 7%Ni/χ-Al ₂ O ₃ (AIP,solvothermal)..... | 47 |
| 5.34 The SEM images of used 7%Ni/γ-Al ₂ O ₃ (AIP,solgel)..... | 48 |
| 5.35 The SEM images of used 7%Ni/γ-Al ₂ O ₃ (AIN,solgel)..... | 48 |
| | |
| B1 The calibrations curve of carbon monoxide. | 56 |
| B2 The calibrations curve of carbon dioxide. | 57 |
| B3 The calibrations curve of hydrogen..... | 57 |
| B4 The calibrations curve of methane. | 58 |
| E1 The calibrations curve of chi phase percent in alumina..... | 60 |
| E2 The XRD pattern of physical mixtures between pure γ- and χ- alumina with various contents..... | 60 |

CHAPTER I

INTRODUCTION

Nowadays, hydrogen production is a very attractive research subject because of the increasing demand for cleaner, safer and more economical energy resources. There are many processes forming Carbon dioxide and emitted to the atmosphere where it gradually accumulates. This carbon dioxide functions as a green-house gas and becomes greenhouse effect. There are also several reactions, such as the CO₂ reforming of methane, in which CO₂ is one of the reactants.

CO₂ reforming of methane to syngas, commonly know as dry reforming of methane. Syngas is a mixture of CO and H₂, which is a versatile feed stock for ammonia, methanol and Fischer–Tropsch Synthesis processes and several other carbonylation and hydrogenation or reduction processes.[Vasant et. Al, 2005] CO₂ reforming of methane is highly endothermic reaction (Eq.1.1). It's normally accompanied by secondary reaction of the reverse water gas shift (Eq.1.2).

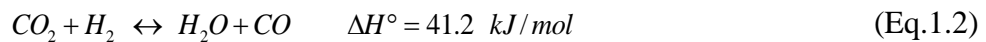
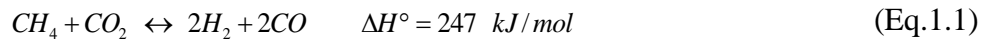

Moreover, the process is high energy consumption, Endothermic reaction. The serious problem is the deactivation of catalyst by carbon formation (Eq.1.3) (Eq.1.4), [Kang et. al, 2007].

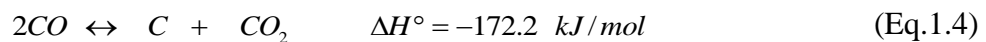
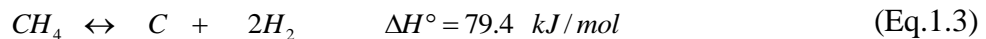

Although noble metals (such as Pt, Ru and Rh) can provide high activity and selectivity with no carbon deposition, but they are not suitable for large scale commercial use due to their high cost and limited availability. So it is more practical to develop non-noble metal catalysts such as Ni, Fe and Co, and they possess high activity as same as noble metals catalysts [Seyma et. al, 2010]

The catalysts support is also studied for CO₂ reforming of methane, there are many studies have shown the catalytic activity from any supports. For example, Amorphous solids (SiO₂ [Guo et. al, 2007], MgO [Wang et al., 2000], CeO₂ [Wang et al., 2000], α -Al₂O₃ [Wang et al., 1997]) and crystalline solids (zeolite [Pawelec et al., 2007], γ -alumina [Hao, 2008]). The result of studies have been investigated that alumina exhibited the high initial activity but there were high coke formation [Kaengsilalai et. al, 2007]. There are several methods to prepare alumina support and the advantage of the sol-gel technology is the ability to produce high purity products at low temperatures (about 400-600°C), and the pore size distribution is very narrow [XiaoRong et. al, 1997]. Therefore this research has investigated the effect of the preparation procedure on promoted Ni/Al₂O₃ catalysts activity for CO₂ reforming.

Research objective

1. To study the effect of precursor and sol-gel preparation procedure of Al₂O₃ supported Nickel catalysts on catalytic activity, stability and coke formation during CO₂ reforming of methane.
2. To study the effect of addition water on feed steam on catalytic activity of CO₂ reforming of methane.

Research scope

1. Preparation of 7% Ni/Al₂O₃ by solvothermal and sol-gel method on support. Catalysts are prepared by incipient wetness impregnation methods.

2. Characterize physical properties of supported nickel catalysts by using various techniques:
 - X-ray diffractometry to determine crystallite size and phase.
 - Nitrogen adsorption to determine BET specific surface area.
 - Ammonia temperature program desorption to determine acidity of catalysts.
 - CO chemisorption to determine quantities of active site of catalysts.
 - Scanning Electron Microscopy (SEM-EDX) to study morphology and metal dispersion of catalysts.
 - Thermogravimetric and differential thermal analysis (TG-DTA) to study carbon deposition.
 - H₂ temperature program reduction to study reducing temperature.

3. Investigation of the performance of the prepared catalysts for carbon dioxide reforming of methane reaction under the following condition:
 - Reaction temperature 600-700 °C.
 - Atmospheric pressure.
 - Reactant feed 50% methane in carbon dioxide.
 - The gas compositions of the reactants and products were analyzed by thermal conductivity detector-type gas chromatograph.

CHAPTER II

THEORY

2. Synthesis gas and hydrogen production

Synthesis gas is a gas mixture contains amount of carbon monoxide and hydrogen. Currently it is produced by gasification of coal and biomass [Beychok, 1974] and combusted in gas turbines. There is another method to produce synthesis gas, it is methane reforming. There are three major processes for hydrogen and synthesis gas production from methane as follows.

Steam reforming



Carbon dioxide reforming



Partial oxidation



The products of reactions, the synthesis gas are converted to organic hydrocarbons by Fischer-Tropsch synthesis. Instead of supplying heat to the steam reforming process, a partial oxidation reaction is also carried out to make it self-sustaining. Another method to produce carbon monoxide and hydrogen from methane is the dry reforming of CO_2 (Eq. 2.1). The carbon dioxide reforming of methane uses 20% more energy than steam reforming of methane (Eq. 2.2) and partial oxidation in shows that (Eq. 2.3), (Eq. 2.4).[Charoenseri, 2007]. Synthesis gas was also using feedstock for methanol synthesis. Another, hydrogen production was using feedstock for ammonia synthesis, hydrotreating, hydrogenation, and fuel cell power. Syngas is also used as an intermediate in producing synthetic petroleum for use as a fuel or lubricant via the Fischer-Tropsch process and previously the Mobil methanol to

gasoline process. The hydrogen must be separated from the CO₂ to be able to use it. For example, pressure swing adsorption (PSA), amine scrubbing, and membrane reactors.

2.2 Reforming reaction of methane by carbon dioxide

Generally, there are three alternative processes for methane reforming to syngas

that have attracted industrial interests and have been studied extensively (Eq.2.5) (Eq.2.6) (Eq.2.7). Steam reforming of methane has been the dominant commercial method employed to produce syngas, but the process has the following limitations:

(a) very high energy consumption, (b) poor selectivity to CO and (c) a high H₂/CO product ratio unsuitable for methanol and Fischer-Tropsch synthesis. [Tung et. al, 2005]

Carbon dioxide reforming of methane

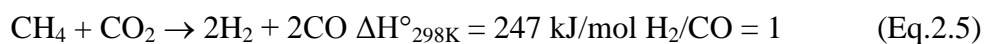

Partial oxidation of methane

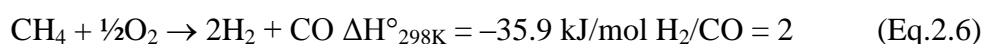

Steam reforming of methane



Although the the catalytic partial oxidation of methane is mildly exothermic, a small decrease in the CO selectivity due to the total combustion of methane (Eq.2.8), which is a highly exothermic reaction, lead to a significant increase in the reaction temperature.

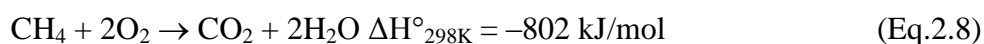

In addition, a high methane conversion coupled with a high space velocity produces

a large amount of heat in a small region of the catalyst. As it is very difficult to remove heat particularly from a large scale reactor, this process is difficult to control. Carbon dioxide reforming of methane has attracted substantial interests over the past decades for both economic and environmental reasons as the process helps to eliminate greenhouse gases while producing syngas. Unlike Steam reforming of methane and Partial oxidation of methane, the Carbon dioxide reforming of methane process is attractive for certain industries as it produces syngas with lower H₂/CO ratio that is a preferable feedstock for Fischer-Tropsch synthesis. Furthermore, both methane and carbon dioxide are among the cheapest and most abundant carbon-containing reactants. Therefore, the CORM reaction is currently one of the important topics in catalytic research for methane utilization.

However, the process has several shortcomings. Dry reforming reaction is intensively endothermic, consumes a large amount of energy and prone to coking. Thus, these problems must first be overcome before the process can be commercialized. Besides the reforming of methane to produce syngas (Eq. 2.5), reverse water gas shift (Eq. 2.9) and several series-parallel side reactions (Eq. 2.9-Eq. 2.15) have indirectly led to lower products yield and concurrently, produced water as undesirable by-product



Solymosi *et al.* (1991, 1993) proposed the most possible mechanism of Carbon dioxide reforming of methane over supported metal catalyst. There is activation carbon formed at the end of reaction and also produce the activation of methane.





Normally, there are several forms of deposited carbons, that are different in reactivity such as adsorbed atomic carbon that is a highly reactive form, amorphous carbon, vermicular carbon, bulk nickel carbide, and crystalline graphitic carbon. The type of catalytic surface, the temperature of its formation and the duration of thermal treatment affect to the reactivity of deposited carbon. The dissociation of carbon dioxide with activation carbon formed at the end of reaction would produce activation of carbon monoxide in shows that is (Eq.2.19). The formation of carbon from carbon monoxide with the precursor is shown by reaction (Eq.2.20).



Both of methane and carbon dioxide can dissociate separately, their deposited products terminate the respective dissociation by covering the metal surfaces. The self-decomposition of both methane and carbon dioxide could be facilitated via reactions (Eq.2.1 - Eq.2.24). The dissociation of methane is enhanced by adsorbed oxygen, while the dissociation of carbon dioxide is also promoted by adsorbed hydrogen and other methane residues. Therefore, the reactions of these surface species also need to be considered as the following reactions:

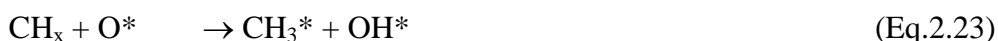
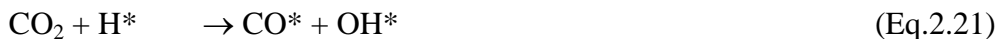

There was also evidence in experiments carried out with cycles of CH_4 and CO_2 that led to the postulation of the oxidation–reduction mechanism depicted in Fig. 2.1.

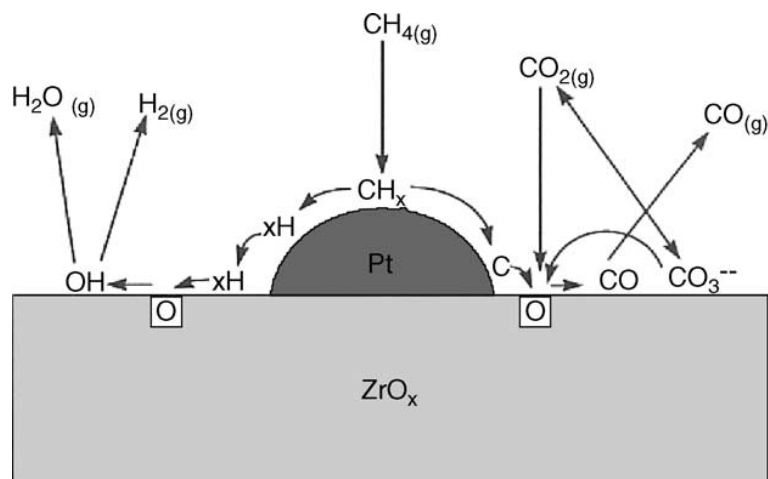

Fig. 2.1. A model for CO_2 reforming of CH_4 over a Pt/ ZrO_2 catalyst. (Reproduced with permission from *Studies in Surface Science and Catalysis* 119 (1998) 819–824).

2.3 Supported catalyst and Metal catalyst

Supported catalyst

Alumina (Al_2O_3) is the most important, widely used and cost effective oxide ceramic material and the most common commercial carriers due to their perfect properties such as high resistance to chemical attacks of strong acids and alkali even at high temperatures, excellent insulating properties and good thermal conductivity. The alumina consists of more than a dozen well-characterized amorphous or crystalline structures. Aluminium oxide exists in many forms that vary over wide range of surface area (0.5-600 m²/g), pore size, pore distribution, surface acidity and any of properties.

Structure

The structure and properties of alumina depend on its preparation, purity, dehydration, and thermal treatment history. The more acidic, high-surface-area alumina hydrate produced at relatively low temperature by precipitation from either acidic or basic solutions and are transformed by dehydration and treatment at high

temperature to ‘transitional’ β , γ , η , χ , δ , and θ - alumina and ultimately α -alumina, all of lower surface area and acidity. Some of the transformations are illustrated as a function of calcination temperature in Figure 2.2, and the physical and structural characteristics of important alumina phase formed at different calcinations temperatures are shown in Table 2.1.

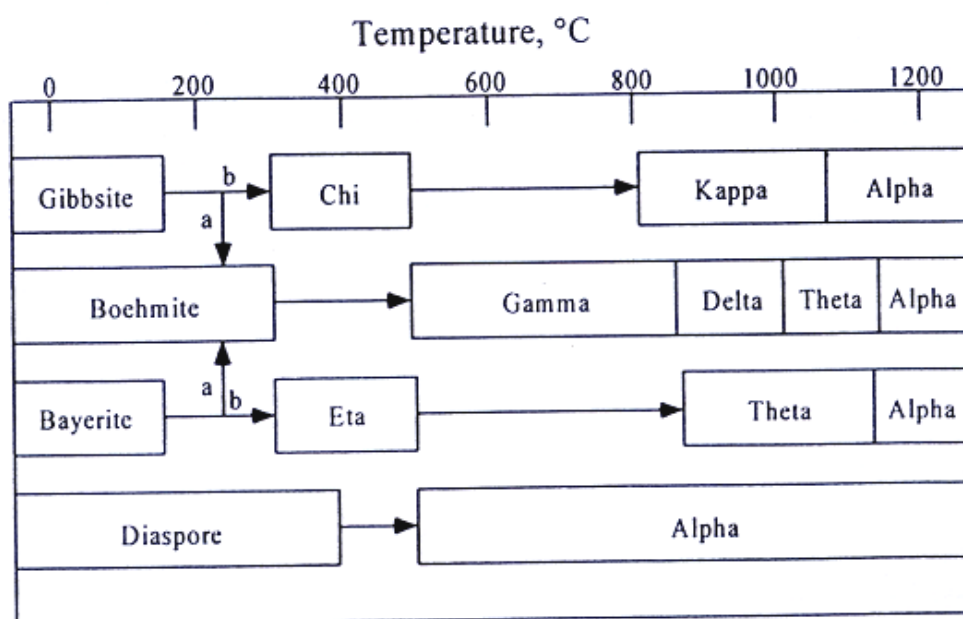

Figure 2.2 Alumina phases present in different temperatures: (a) corresponds to the path favored for fine crystals, (b) to the path for moist or particles.

Table 2.1 Physical and structural characteristic of common aluminum oxides.

| Tcalc(°C) | Alumina phase | SA, (m ² /g) | Vpore, (cm ³ /g) | Dpore, (nm) |
|-----------|--------------------|-------------------------|-----------------------------|-------------|
| 250 | pseudoboehmite | 390 | 0.50 | 5.2 |
| 450 | γ - alumina | 335 | 0.53 | 6.4 |
| 650 | | 226 | 0.55 | 9.8 |
| 850 | | 167 | 0.58 | 14 |
| 950 | δ - alumina | 120 | 0.50 | 16.6 |
| 1050 | θ - alumina | 50 | 0.50 | 28 |
| 1200 | α - alumina | 1-5 | | |

Synthesis

There are many synthesis of alumina and in this research has investigated the influences of preparation of alumina also. Alumina was prepared by solvothermal method and sol-gel method.

Solvothermal method has been developed from hydrothermal method for synthesis of metal oxide and binary metal oxide, by using solvent as the reaction medium under pressure and the temperature above its normal boiling point. The advantage of the solvothermal method are given products with uniform morphology, well controlled chemical position, narrow particle size distribution, controlled crystal structure, and controlled grains and morphologies can be controlled by process conditions such as solute concentration, reaction temperature, reaction time and type of solvent.

The sol-gel method appears to be promising as it is low cost, offers good adhesion to metallic surface via chemical bonding, and easy adaptability in industries due to its simple application procedure. One of the main advantages of sol-gel method is its capacity to yield coatings with a wide range of compositions on different substrates without limitation of size or geometry of the work piece [Brinker et. al, 1992]

Usage

Aluminum oxide is used in a variety reactions including; benzene hydrogenation, catalytic reforming, hydrotreating, emission control, methanol synthesis, the water gas shift reaction, and oxychlorination. its largest scale application, alumina is the catalyst in the Claus process for converting hydrogen sulfide waste gases into elemental sulfur in refineries. It is also useful for dehydration of alcohols to alkenes. Alumina serves as a catalyst support for many industrial catalysts, such as those used in hydrodesulfurization and some Ziegler-Natta polymerizations. Zeolites are produced from alumina.

Metal catalyst

It is well known that noble metals (such as Pt, Ru and Rh) can provide high activity and selectivity with no carbon deposition, but they are not suitable for large scale commercial use due to their high cost and limited availability. Nevertheless it has been reported that a high dispersion of Nickel particles over basic supports, as well as a strong interaction between the metal and the support can reduce or suppress the carbon formation [Sivaiah et. al,2010] As a consequence, Ni catalysts was used to improve activity, selectivity and preventing of coke formation on catalyst.

CHAPTER III

LITERATURE REVIEWS

Effect of supported catalysts in reforming of methane by carbon dioxide

The early study of the effect of support phase on catalytic activity and carbon deposition were systematically investigated over nickel catalysts supported on Al_2O_3 , SiO_2 and MgO for the reforming reaction of methane with carbon dioxide by Shaobin Wang and G.Q.M. Lu (1997). The result shows that $\text{Ni}/\gamma\text{-Al}_2\text{O}_3$ and $\text{Ni}/\alpha\text{-Al}_2\text{O}_3$ catalysts gave highly CH_4 and CO_2 conversions. The conversions of reforming reaction of methane with carbon dioxide on the $\text{Ni}/\gamma\text{-Al}_2\text{O}_3$ catalyst were slightly higher than the $\text{Ni}/\alpha\text{-Al}_2\text{O}_3$ catalyst at the same temperature. They reported that the difference could be attributed to the stable allotropic form of α -alumina and its lower surface area. The low porosity decreased the amount of contacting to gas that had with the catalyst surface so the conversion was lower. The comparison of the amount of carbon deposition, the result was $\text{Ni}/\alpha\text{-Al}_2\text{O}_3$ had higher coke deposition than $\text{Ni}/\gamma\text{-Al}_2\text{O}_3$ catalyst. They reported the pore structure of the support and metal-support interaction significantly affected the catalytic activity and coking resistance. Catalyst with well-developed porosity exhibited higher catalytic activity. The catalyst is more resistant to sintering and coking because of strong interaction between metal and the support made, and due to catalyst stability.

XiaoRong Huang et. al,(1997) studied preparation of unsupported alumina membrane by sol-gel techniques. The catalyst, unsupported alumina membranes were prepared by sol-gel technique using aluminum isopropoxide. The influence of the hydrolysis conditions, the type and concentration of peptizant acid on the boehmite sols has been studied. They reported that the products were produce the most when

the hydrolysis temperature for the aluminum isopropoxide was above 50°C. Rapid gelation processing of sols obtained crack-free unsupported alumina membranes.

Julian R.H. Ross (2005) reviews work from the author's laboratories summarises work on the steam reforming and CO₂ reforming reactions, discussing some catalysts developed for these reactions. The production of syngas from natural gas (and also of other hydrocarbons) can be achieved by a number of different reactions. The best established of these is steam reforming, this giving an H₂/CO ratio of 3.0, the ratio being then adjusted as required by using the water-gas shift reaction. CO₂ reforming gives rise to a syngas ratio of 1.0, this being that required for a small number of processes. Finally, the all-over CO₂ balances of a number of reaction sequences for the utilisation of CO₂ are presented, these showing that the production of carbon by a sequence involving CO₂ reforming of methane followed by reduction of CO might be used to remove CO₂ under certain circumstances; the C so produced could either be used as an energy carrier or disposed of.

The study of effect of metal-support interaction on coking resistant of Rh/Al₂O₃, Rh/SiO₂, and Rh/CeO₂ catalyst during CH₄/CO₂ reforming by Wang Rui et al. (2007). They reported that the initial CH₄ activity were in order: Rh/Al₂O₃ > Rh/SiO₂ > Rh/CeO₂. The presence implied that the sequence of exposed Rh surface area of reduced catalyst indeed coincides with the activity due to Rh dispersion on support. Moreover, they reported that after test reaction about 25 hour the stability of catalyst after 25 hour of reaction increased in the order: Rh/SiO₂ < Rh/Al₂O₃ < Rh/CeO₂, that are in the reverse of the amount of deposition carbon. The results lead to suggest that the stability might be associated with the coking resistant of catalyst during CO₂ reforming of methane.

Influence of K, Sn, Mn and Ca on the behavior of a Ni-Al₂O₃ catalyst, prepared by a sol-gel method studied by Adolfo E. et al. (2008). Ni-Al₂O₃ catalyst was prepared by sol-gel method and showed an excellent performance in the reaction

of methane carbon dioxide reforming, with high and stable catalytic activity. They reported the effect of metal loading with 0.5 %wt. of K, Ca, Sn and Mn, compared with the catalyst with no supported. The result of the Ca, Mn and Sn-modified catalysts, dramatically reduced of catalytic activity and significantly increased in carbon deposition while running the reaction in the period of studied time. The catalyst with K showed less carbon on catalyst, high stability and high catalytic activity. The unmodified catalyst showed the catalytic activity, in methane conversion decreasing less than 4%. The result showed that potassium migrates from the support to the surface of nickel and neutralizes a fraction of the most active sites for the reforming reaction producing lead to decreasing in methane conversion.

Synthesis and characterization of a highly active alumina catalyst for methanol dehydration to dimethyl ether was studied by Seung-Moon Kim et. al,(2008) A simple sol-gel method was adopted to synthesize boehmites with high surface area using aluminum

iso-propoxide (AIP), acetic acid (AA) and 2-propanol, and the effects of surface area and methanol dehydration on activity were investigated. The hydrolysis conditions of AIP in the presence of AA in 2- propanol solvent were systematically varied to observe their effect on phase formation, crystallinity, surface area and pore size distribution of the alumina. Addition of acetic acid enhances the textural and structural characteristics of boehmite. Thermal treatment of the boehmite at 550 °C gives a high surface area γ -Al₂O₃ powder having controlled porosity and pore size distribution. The acetic acid adsorbed on the surface plays a crucial role in controlling the morphology of the boehmite precursor as well as that of the γ -Al₂O₃ powder. They reported in the present study that the structure-property relationship observed that is useful to make tailor made γ -Al₂O₃ with high surface acidity. However, catalytic activity was controlled by changing the AA/AIP and H₂O/AIP molar ratios.

In 2007, M. Simeone et. al, studied Effect of water addition and stoichiometry variations on temperature profiles in an autothermal methane reforming reactor with Ni catalyst. They reported when the water was added to the reaction, peak temperature lower than before but peak position did not move. In addition, when H₂O/CH₄ ratio varied from 0 to 1.2, methane conversion increased by 4% at constant oven temperature and by 8% at constant peak temperature. As a consequence, they found that catalyst deactivation and coke formation were estimated by measuring temperature distribution in catalyst bed.

Zhigang Hao et al. (2008) studied characterization of aerogel Ni/Al₂O₃ catalysts and investigation on their stability for CH₄-CO₂ reforming in a fluidized bed. The CH₄-CO₂ reforming was investigated in a fluidized bed reactor using nano-sized aerogel Ni/Al₂O₃ catalysts, which were prepared via a sol-gel method combined with a supercritical drying process. The catalysts were characterized with BET, XRD, H₂-TPR and H₂-TPD techniques. When compared with the impregnation catalyst, aerogel catalysts exhibited higher specific surface areas, lower bulk density, smaller Ni particle sizes, stronger metal-support interaction and higher Ni dispersion degrees. They reported that all tested aerogel catalysts showed better catalytic activities and stability than the impregnation catalyst. After tested reaction about 48 h the catalytic stability was dependent on their Ni loadings. The result from characterizations of used catalysts indicated that only limited graphitic carbon formed on the aerogel catalyst, while there were many graphitic carbon with filamentous morphology was observed for the impregnation catalyst. They reported that an aerogel catalyst containing 10% Ni showed the best catalytic stability and the lowest rate of carbon deposition among the aerogel catalysts due to its small Ni particle size and strong metal-support interaction.

CHAPTER IV

EXPERIMENTAL

This chapter consists of the 3 experimental sections. There are preparation of nickel catalyst on supported nickel catalysts in. Second is the characterization of nickel catalyst on supported by using X-Ray Diffraction (XRD), Scanning Electron Microscopy (SEM-EDX), Nitrogen physisorption, CO chemisorption, Transmission Electron Microscopy (TEM), Ammonia Temperature Program Desorption (NH₃-TPD), Hydrogen Temperature Program Reduction (H₂-TPR), and Thermo gravimetric and differential thermal analysis (TG-DTA). Finally, the effects of preparation method of nickel catalyst on alumina in the carbon dioxide reforming of methane.

In this study, Alumina oxide was obtained from commercial grade and also synthesized by solvothermal method and sol-gel method. Source of alumina oxide are aluminum isopropoxide and aluminium nitrate. The catalysts of varying precursor alumina and difference of synthesis were compared.

4.1 Catalyst preparation

4.1.1 Chemical for preparation

Alumina supports by solvothermal method

1. Alumina Isopropoxide: AIP, $[(\text{CH}_3)_2\text{CHO}]_3\text{Al}$ from Aldrich.
2. 1-Butanol, (C₄H₉OH) from Fluka.
3. Toluene, (C₆H₅CH₃) from Fisher Scientific.
4. Methanol, (CH₃OH) from Merck.
5. Nitrogen, (N₂) from TIG.

Alumina supports by sol-gel method

1. Alumina Isopropoxide: AIP, $[(\text{CH}_3)_2\text{CHO}]_3\text{Al}$ from Aldrich.
2. Aluminium nitrate: AlN₃O₉.9H₂O from Fluka
3. Ethanol, (C₂H₅OH) from Merck

4. Hydrochloric acid, (HCl) from Fluka

Nickel loading on supports

1. Ni (NO₃)₂•6H₂O, from Merck

4.1.2 Preparation procedures

4.1.2.1 Preparation of various phases of alumina supports by solvothermal method

Alumina was prepared by 15 grams of aluminum isopropoxide was suspended in 100 ml of desired organic solvent in a test tube, the organic solvents using in this experiments were toluene, 1-butanol and the mixed solvents thereof with desired composition. Then the test tube was placed in a 300 ml autoclave. An additional 30 ml of same solvent was placed in the gap between the autoclave wall and the test tube. The autoclave was completely purged with nitrogen, heated to a desired temperature (300°C) at a rate of 2.5 °C min⁻¹ and kept at that temperature for 2 h. After that the autoclave was cooled to room temperature. The product was repeatedly washed with methanol by vigorous mixing and centrifuging and then dried in air. The as-synthesized powders were calcined in air at 600 °C for 6 h with a heating rate of 10°C/min. [J.Khom-in, 2007].

Table 4.1 χ/γ ratio in preparing catalysts of solvothermal method.

| χ/γ ratio | In test tub, (ml) | | In the gap between the autoclave wall and the test tube, (ml) | |
|------------------------|-------------------|-----------|---|-----------|
| | Toluene | 1-Butanol | Toluene | 1-Butanol |
| 0/100 | 0 | 100 | 0 | 30 |
| 50/50 | 50 | 50 | 15 | 15 |
| 100/0 | 100 | 0 | 30 | 0 |

4.1.2.2 Preparation of various phases of alumina supports by sol-gel method

Alumina was prepared by 15 grams of Alumina Isopropoxide or Aluminium nitrate was mixed with mixture solution of water and ethanol with volume ratio 1:1. The solutions were stirred and evaporated at 80°C and was subsequently kept at about 90°C

About 10 h until eliminating the solvent. The pastes generated were dried at 100°C overnight and calcined in air for 2 h at 550°C, before use.

4.1.2.3 Nickel loading on supports

Ni-based catalysts were prepared with 5wt%, 7 wt%, 10 wt% Ni and the catalysts were prepared by incipient wetness impregnation method using Ni (NO₃)₂•6H₂O (Merck) as the metal precursors. The incipient wetness impregnation procedure was as following:

First of all, Nickel nitrate (5wt%, 7 wt%, 10 wt%) was dissolved in deionized water in an equal volume to pore volume of catalyst. And the catalyst support was impregnated with aqueous solution of nickel by the incipient wetness technique. While the solution was dropped slowly to the catalyst support. Then the impregnated support was left to stand at room temperature for 4 hours to assure adequate distribution of metal complex. After that the catalyst was dried in the oven at 110 °C overnight. Finally, the catalyst was calcined in air at 500°C for 5 hours.

4.2 Catalyst characterization

4.2.1 X-ray diffraction pattern

X-ray diffraction (XRD) by an X-ray diffractometer SIEMENS D 5000 identifies the crystallinity of the prepared catalysts powder by connected with a personal computer with Diffract AT version 3.3 program for fully control of the XRD analyzer. The experiments were carried out by using Ni-filtered Cu K α radiations with

a generator voltage and current of 30 kV and 30 mA, respectively. A scan step of 0.04° was applied during a continuous run in the $6-80^\circ$ range.

4.2.2 Nitrogen physisorption

The catalyst 0.2 gram was study BET surface area, pore volume and pore diameter were measured by N_2 adsorption–desorption isotherm at liquid nitrogen temperature

(-196°C) using a Micromeritics ASAP 2020. The surface area and pore distribution were calculated according to Brunauer-Emmett-Teller (BET) and Barret-Joyner-Halenda (BJH) methods, consecutively.

4.2.3 Temperature Programmed Desorption of Ammonia (NH_3 -TPD)

The acid properties of prepared catalysts were calculated by Temperature Programmed Adsorption of Ammonia (NH_3 -TPD) equipment by using Micromeritics chemisorp 2750 Pulse Chemisorption System. In an experiment, about 0.10 g of the catalyst sample was placed in a quartz tube and pretreated at 200°C in a flow of helium. The sample was saturated with 15% NH_3 /He. When the saturation finished, the physisorbed ammonia was desorped in a helium gas flow about 1.0 h. And the sample was heated from 40 to 800°C at a heating rate $10^\circ\text{C}/\text{min}$. The amount of ammonia in effluent was measured via TCD signal as a function of temperature.

4.2.4 Scanning Electron Microscopy (SEM)

Scanning Electron Microscopy was employed for including the shape and size of the prepared zeolite crystal. The JEOL JSM-35 CF model at the Scientific and Technology Research Equipment Centre, Chulalongkorn University (STREC) was used for this purpose.

4.2.5 CO Chemisorption

CO chemisorption at room temperature on the reduce catalysts will be used to determine the number of reduce surface nickel metal atoms. The total CO chemisorption will be calculated from the number of injection of a known volume. CO chemisorption will be carried out following the procedure using a Micromeritics

Pulse Chemisorb 2750 instrument at the Analysis Center of Department of Chemical Engineering, Faculty of Engineering, Chulalongkorn University. In an experiment, about 0.20 g of the catalyst sample was placed in a quartz tube. Prior to chemisorption, the catalysts will be reduced at 600 °C for 1 hour after ramping up at a rate of 10 °C/min. After, carbon monoxide 86 microlite was inject to catalyst and repeat until desorption peak constant. Amount of carbon monoxide adsorption on catalyst was relative amount of active site.

4.2.6 Thermogravimetric and differential thermal analysis (TG-DTA)

The as-spun alumina fibers was subjected to the thermogravimetric and differential thermal analysis (Diamond Thermogravimetric and Differential Analyzer, TA Instruments SDT Q600) to determine the carbon content in the sample, as well as their thermal behaviors in the range of 10-800 °C. The analysis was performed at a heating rate of 10 °C /min in 100 ml/min flow of air.

4.3 Reaction Activity

4.3.1 Chemical for reaction

1. UHP Nitrogen Gas, 99.999%
2. UHP Hydrogen Gas, 99.999%
3. Feed Gas: 50% Methane in Carbon dioxide

4.3.2 Instrument and Apparatus

(a) Reactor: The reactor was a fixed bed reactor made from a Quartz tube with an inner diameter of 12 mm. and length of 50 mm.

(b) Automatic Temperature and Controller: There is a magnetic switch connected to a variable voltage transformer and a temperature controller connected to a thermocouple attached to the catalyst bed in reactor. A dial setting established a set point at any temperature within the range between 0°C to 1000°C.

(c) Electric Furnace: This supply the required heated to the reactor for reaction. The reactor could be operating at 700°C.

(d) Gas Controlling Systems: Gas was equipped with pressure regulator (0-120 psig), an on-off valve and needle valve were used to adjust flow rate of gas.

(e) Gas Chromatographs: Operating conditions were shown in Table 3.2.

Table 4.2 Operating condition gas chromatograph for CH₄/CO₂ to syngas.

| Gas Chromatograph | Shimazu, GC 8A | Shimazu, GC 8A |
|----------------------|-----------------|--------------------------------------|
| Detector | TCD | TCD |
| Column | Porapak-Q | Molecular sieve 5A |
| Carrier gas | Ar | Ar |
| Carrier gas flow | 30 ml/min | 30 ml/min |
| Column Temperature | | |
| - Initial | 60 °C | 60 °C |
| - Final | 60 °C | 60 °C |
| Detector temperature | 100 °C | 100 °C |
| Injector Temperature | 100 °C | 100 °C |
| Analyzed gas | CO ₂ | CH ₄ , CO, H ₂ |

4.3.3 Reaction Method

The experiments were performed in a fixed-bed reactor, with an inner diameter of 12 mm and length 50 mm., imbedded in an insulated electric furnace equipped with a temperature programmable controller. A K-type thermocouple was inserted into the catalyst bed to measure and control the bed temperature. The reactant gas stream consisted of CO₂ and CH₄ with a molar ratio of 1:1 at a total flow rate of 100 ml/min. A fresh 0.2 g catalyst sample was packed into the reactor and reduced in flowing hydrogen at 600 °C for 1 h. Then purged with flowing nitrogen at the reaction temperature for 45 min. The catalytic activity was studied at 700 °C. Steam is applied to the system by evaporating distilled water in a evaporator at 100 °C and the process lines are controlled at 100 °C to prevent any condensation of steam. The scheme diagram of reforming reaction of methane by CO₂ was shown in Figure 3.1 The gas compositions of the reactants and products were analyzed by Thermal Conductivity Detector-type gas chromatographs, Shimudzu GC-8A equipped with a Porapak-Q and Molecular sieve 5A packed column.

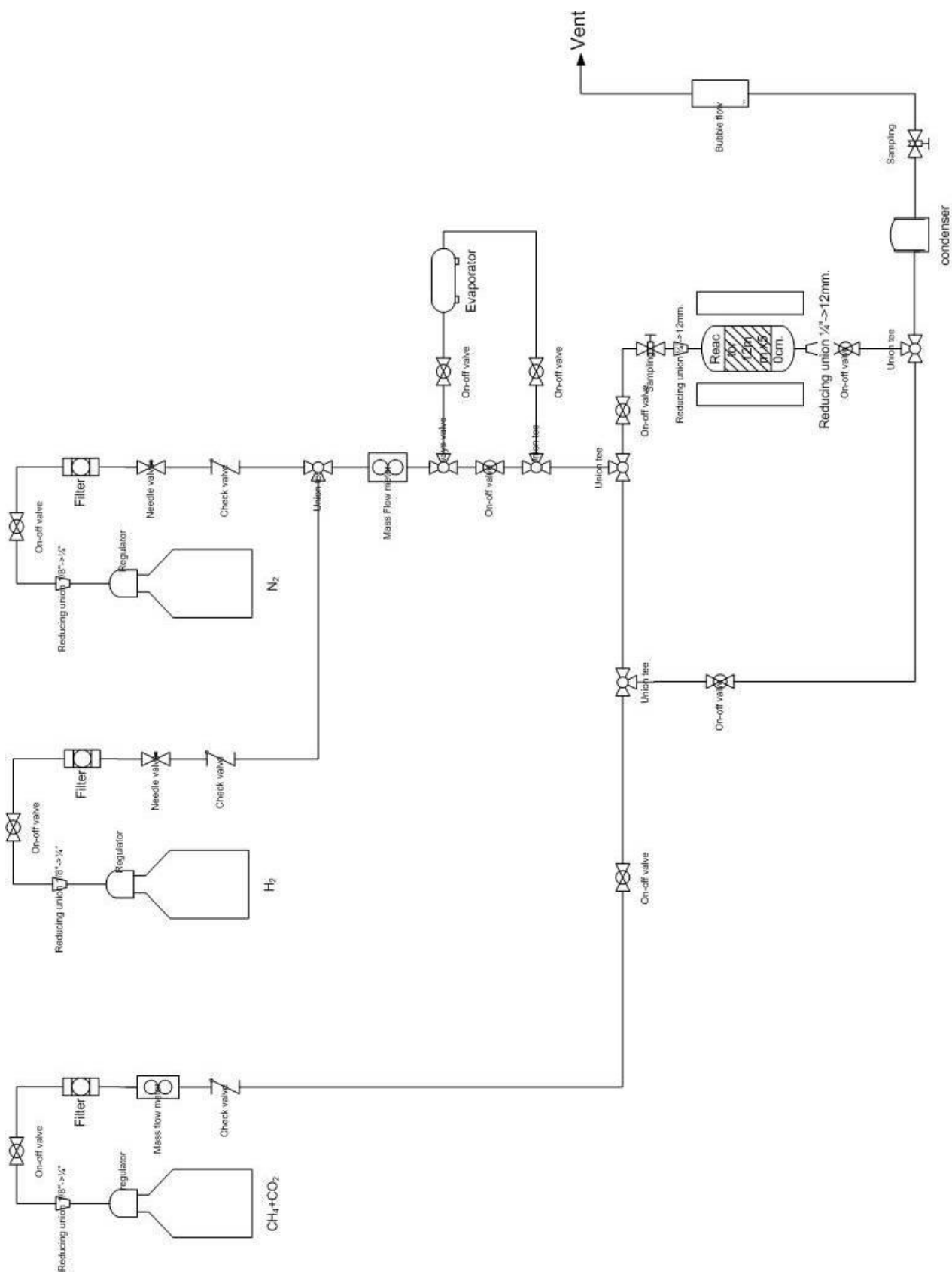

Figure 4.1 Scheme diagram of reforming reaction of methane by CO_2

The conversions of CH₄ and CO₂ and selectivity of H₂ and CO are defined in equation show are (Eq.4.1), (Eq.4.2), (Eq.4.3) and (Eq.4.4) as follows:

$$X_{CH_4} = \frac{[CH_4]_{in} - [CH_4]_{out}}{[CH_4]_{in}} \times 100 \quad (\text{Eq.4.1})$$

$$X_{CO_2} = \frac{[CO_2]_{in} - [CO_2]_{out}}{[CO_2]_{in}} \times 100 \quad (\text{Eq.4.2})$$

$$S_{H_2} = \frac{1}{2} \frac{[H_2]_{out}}{[CH_4]_{in} - [CH_4]_{out}} \times 100 \quad (\text{Eq.4.3})$$

$$S_{CO} = \frac{[CO]_{out}}{[CH_4]_{in} - [CH_4]_{out} + [CO_2]_{in} - [CO_2]_{out}} \times 100 \quad (\text{Eq.4.4})$$

[CH₄]_{in} and [CO₂]_{in} are the flow rates of the introduced reactants and [CH₄]_{out}, [CO₂]_{out}, [H₂]_{out}, and [CO]_{out} are the flow rates of the corresponding compositions in the effluents of carbon dioxide reforming of methane.

CHAPTER V

RESULTS AND DISCUSSIONS

5.1 The effect phase of alumina supported nickel catalyst on catalytic activity

5.1.1 Characterization of catalyst

5.1.1.1 X-Ray Diffraction

The X-Ray Diffraction patterns of the γ – alumina, χ - alumina and mix phased alumina prepared by solvothermal methods and commercial γ - Al_2O_3 support supported Ni are shown in Figure 5.1. The XRD patterns of synthetic of alumina and commercial γ - Al_2O_3 were shown at 32° , 37° , 39° , 45° , 61° and 66° as pure γ - phase. And the position of χ -alumina was assigned at 43° . [Meephoka et al. 2008].

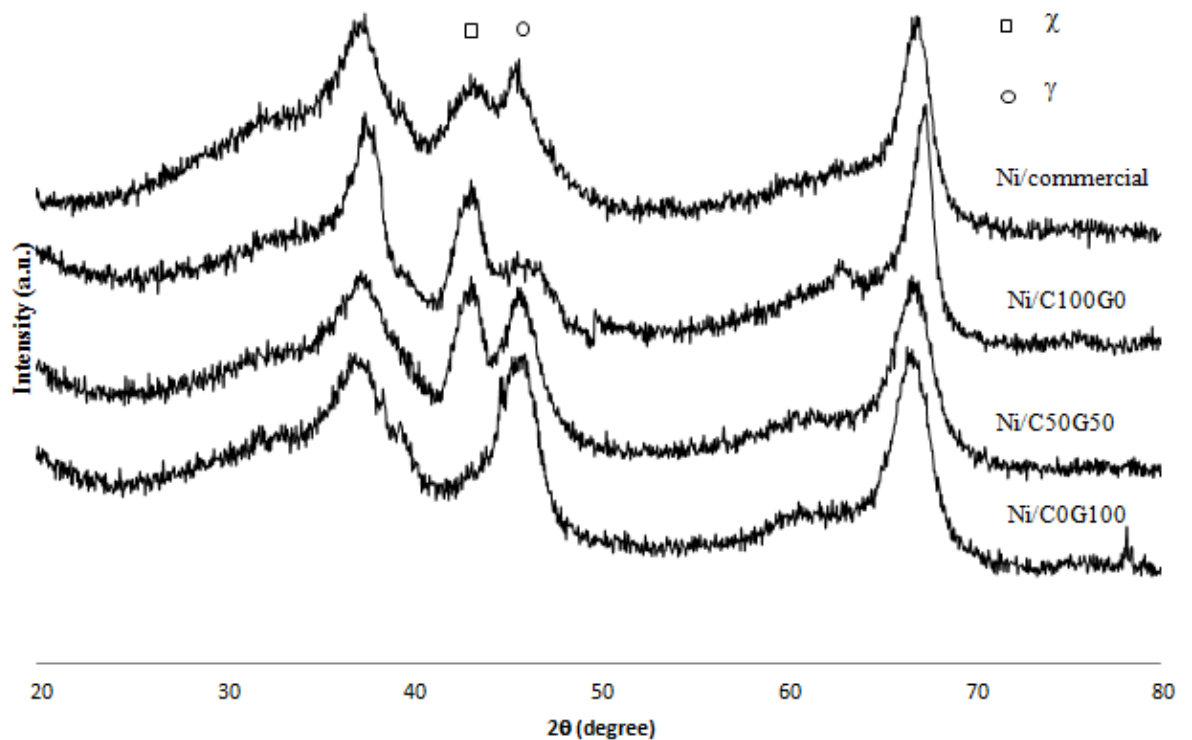

Figure 5.1 XRD patterns of synthetic mixed phase of 7% Nickel loaded on alumina (Ni/C100G0, Ni/C50G50, Ni/C0G100) and the commercial γ - Al_2O_3 .

Figure 5.2 shows XRD pattern of 7% wt Ni catalyst on synthetic γ -Al₂O₃ prepared by sol-gel methods (AIP and Aluminium nitrate as a precursor) and γ -Al₂O₃ prepared by solvothermal methods were occurred at 32°, 37°, 39°, 45°, 61° and 66° as γ - phase [Meephoka et al. 2008] with all methods and precursors of catalysts. And XRD patterns of 7% Ni/ γ -alumina which prepared by sol-gel and AIP as precursor was shown in Figure 5.3

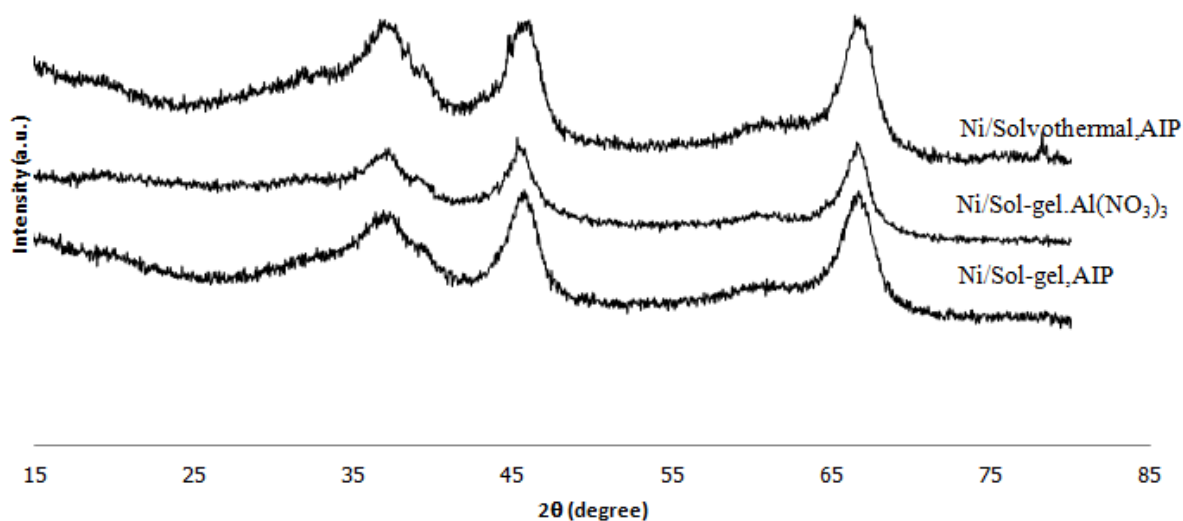

Figure 5.2 XRD patterns of 7% Ni- alumina in any preparation and precursor (Ni/Solvothermal,AIP, Ni/Sol-gel,Al(NO₃)₃, Ni/Sol-gel,AIP)

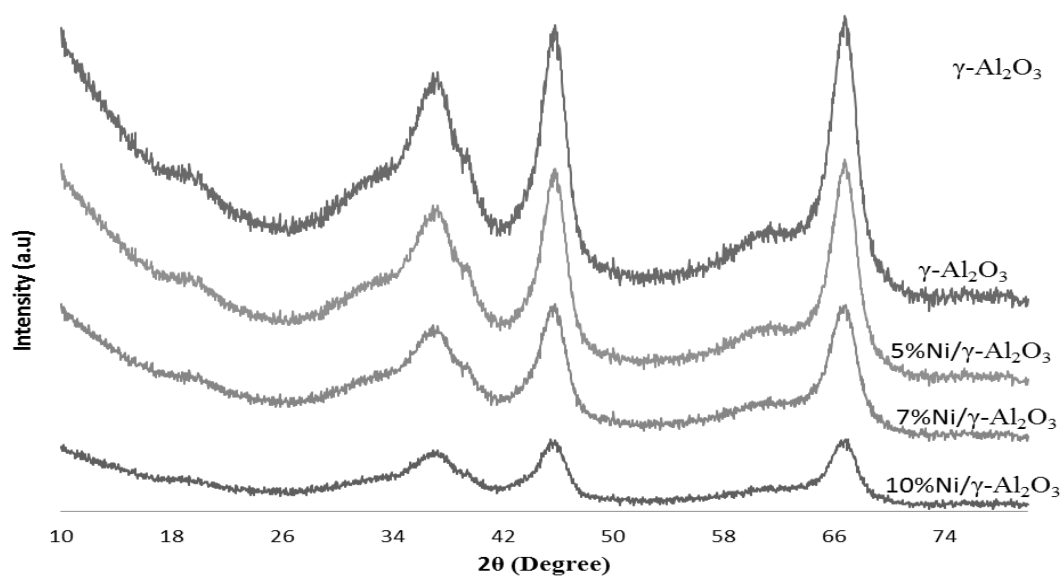

Figure 5.3 XRD patterns of Ni/ γ -alumina which prepared by sol-gel.

5.1.1.2 Nitrogen physisorption

The BET surface areas of catalyst are determined by N_2 adsorption–desorption isotherm at liquid nitrogen and calculated by BET technique.

Table 5.1 BET surface area of Nickel supported on alumina catalysts

| Catalysts | BET surface area (m^2/g) |
|---|---------------------------------|
| 7%Ni/ γ - Al_2O_3 (commercial) | 74.23 |
| 7%Ni/ γ - Al_2O_3 (AIP,solvothermal) | 83.93 |
| 7%Ni/50% γ - χ - Al_2O_3 (AIP,solvothermal) | 103.61 |
| 7%Ni/ χ - Al_2O_3 (AIP,solvothermal) | 93.31 |
| 5%Ni/ γ - Al_2O_3 (AIP,solgel) | 123.22 |
| 7%Ni/ γ - Al_2O_3 (AIP,solgel) | 109.99 |
| 10%Ni/ γ - Al_2O_3 (AIP,solgel) | 105.46 |
| 7%Ni/ γ - Al_2O_3 (AIN,solgel) | 95.30 |

The results are shown in Table 5.1, it is found that BET surface area of all catalysts decreased when the addition of Nickel. The 7% Ni supported on alumina shown that Ni/ γ -Al₂O₃ (AIP, solgel) gives the highest of BET surface area and Ni/ γ -Al₂O₃ (commercial) gives the lowest of BET surface area.

5.1.1.3 Ammonia Temperature Programmed Desorption (NH₃-TPD)

The NH₃-TPD profiles of supported nickel catalyst with different support are shown in Figure 5.4. The profiles are found of two peaks which at a low temperature peak representing weak acid sites and a high temperature one representing to strong acid sites. All support showed two broad peaks in range of the temperature around of 40 to 250°C and 200 to 500°C, respectively. 7%Ni/ γ -Al₂O₃ (AIP, solgel) has the highest acidity than that of among commercial other 7%Ni supported on alumina. Table 5.3 showed the acid properties of the alumina catalysts. The acid properties are calculated by method in Appendix D. The increasing order of total acidity concentration (mmol H⁺/g catalyst) is as follows: 7%Ni/50% γ - χ -Al₂O₃ (AIP, solvothermal) > 7%Ni/ γ -Al₂O₃ (AIN, solgel) > 7%Ni/ γ -Al₂O₃ (AIP, solgel) > 7%Ni/ χ -Al₂O₃ (AIP, solvothermal) > 7%Ni/ γ -Al₂O₃ (AIP, solvothermal) > 7%Ni/ γ -Al₂O₃ (commercial)

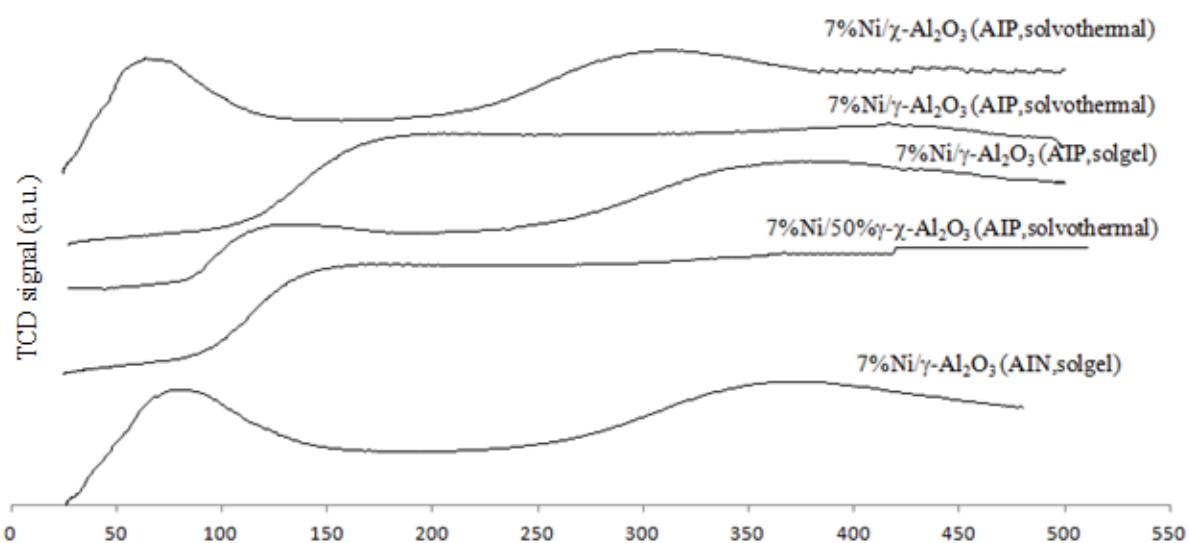

Figure 5.3 The NH₃-TPD profile of synthetic alumina supported 7% wt of Nickel

Table 5.2 Acidity of synthetic alumina supported.

| Catalyst | Adsorbed volume of ammonia, (ml) | Total acid site, (mmol H ⁺ /g) |
|--|----------------------------------|---|
| 7%Ni/γ-Al ₂ O ₃ (commercial) | 3.461 | 1.398 |
| 7%Ni/γ-Al ₂ O ₃ (AIP,solvothermal) | 4.815 | 1.944 |
| 7%Ni/50%γ-χ-Al ₂ O ₃ (AIP,solvothermal) | 6.833 | 2.786 |
| 7%Ni/χ-Al ₂ O ₃ (AIP,solvothermal) | 4.997 | 2.017 |
| 7%Ni/γ-Al ₂ O ₃ (AIP,solgel) | 5.593 | 2.264 |
| 7%Ni/γ-Al ₂ O ₃ (AIN,solgel) | 5.939 | 2.39 |

5.1.1.4 CO-chemisorption

CO chemisorption at room temperature on the reduced catalysts are used to calculate the number of reduce surface nickel metal atoms. Active site of catalysts are calculated from amount of carbon monoxide adsorption on catalysts. The calculation the active site of catalysts are shown in Appendix C. And the amount of absorbed carbon monoxide is directly proportional to the active site as the higher absorbed amount of carbon monoxide means the higher active site in catalysts too. Table 5.4 showed that mixed phase between 10%Ni/ γ -Al₂O₃ (AIP,solgel) has the highest active site but just more a little bit than 7%Ni/ γ -Al₂O₃ (AIP,solgel). Among of alumina which prepared by solvothermal, amount of active site of 50% χ - γ - alumina has higher than pure χ -alumina and pure γ -alumina respectively. Table 5.4. shows the data of crystallite size and percent dispersion of nickel catalyst. The percent dispersion of nickel catalyst are determined by calculation from amount of carbon monoxide adsorption on catalysts that shown in Appendix C. The 10%Ni/ γ -Al₂O₃ (AIP,solgel) has the highest dispersed than others.

Table 5.4 Amount of carbon monoxide adsorbed on catalysts.

| Catalyst | Active site, Molecule $\times 10^{-18}$ per gram | % dispersion of Nickel |
|---|--|---------------------------|
| 7%Ni/ γ -Al ₂ O ₃ (commercial) | 10.29 | 2.01 |
| 7%Ni/ γ -Al ₂ O ₃ (AIP,solvothermal) | 12.56 | 2.45 |
| 7%Ni/50% γ - χ -Al ₂ O ₃ (AIP,solvothermal) | 15.28 | 2.98 |
| 7%Ni/ χ -Al ₂ O ₃ (AIP,solvothermal) | 14.41 | 2.81 |
| 5%Ni/ γ -Al ₂ O ₃ (AIP,solgel) | 11.50 | 2.24 |
| 7%Ni/ γ -Al ₂ O ₃ (AIP,solgel) | 17.21 | 3.36 |
| 10%Ni/ γ -Al ₂ O ₃ (AIP,solgel) | 18.02 | 3.51 |
| 7%Ni/ γ -Al ₂ O ₃ (AIN,solgel) | 14.65 | 2.86 |

5.1.2 Reaction study of commercial γ - Al_2O_3 and synthetic Al_2O_3 supported Nickel catalysts

5.1.2.1 Reaction study of commercial γ - Al_2O_3 and synthetic Al_2O_3 supported Nickel catalysts

The effect of various phase of alumina was shown in Figure 5.4, 5.5, 5.6 and 5.7 which are consist of methane conversion, carbon dioxide conversion, selective of carbon monoxide and selective of hydrogen. The result showed that 7%Ni/50% γ - χ - Al_2O_3 (AIP,solvothermal) gave the highest methane conversion among the other phases and also gave the highest hydrogen selective which are the main product of this reaction.

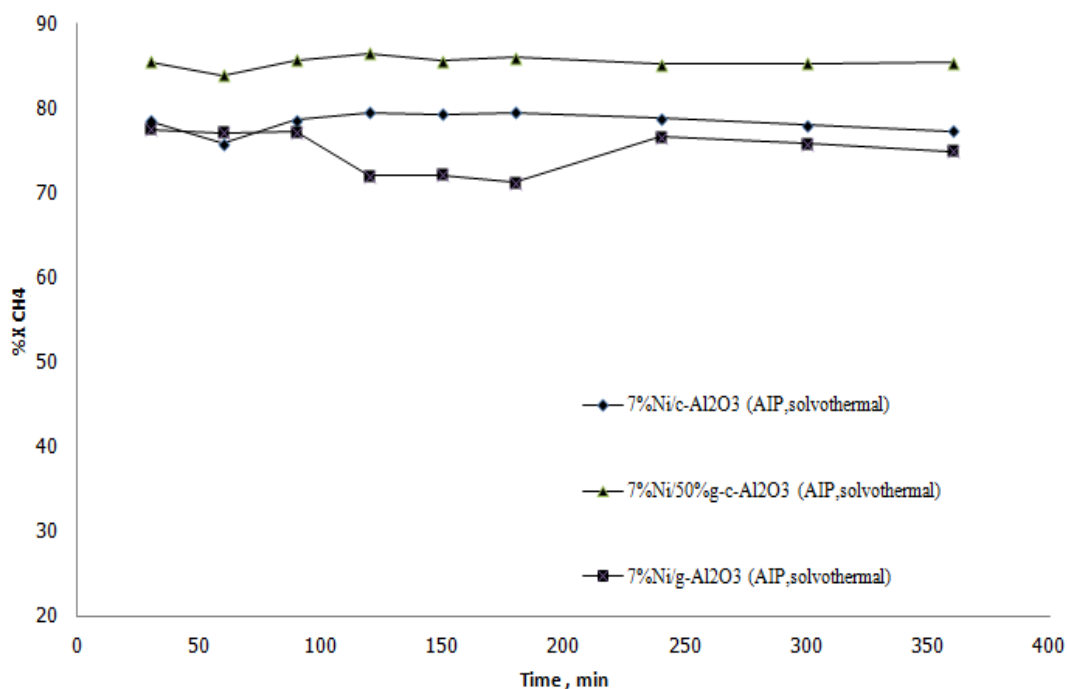

Figure 5.4 The effect of supported-nickel catalyst on the conversion of CH_4 .

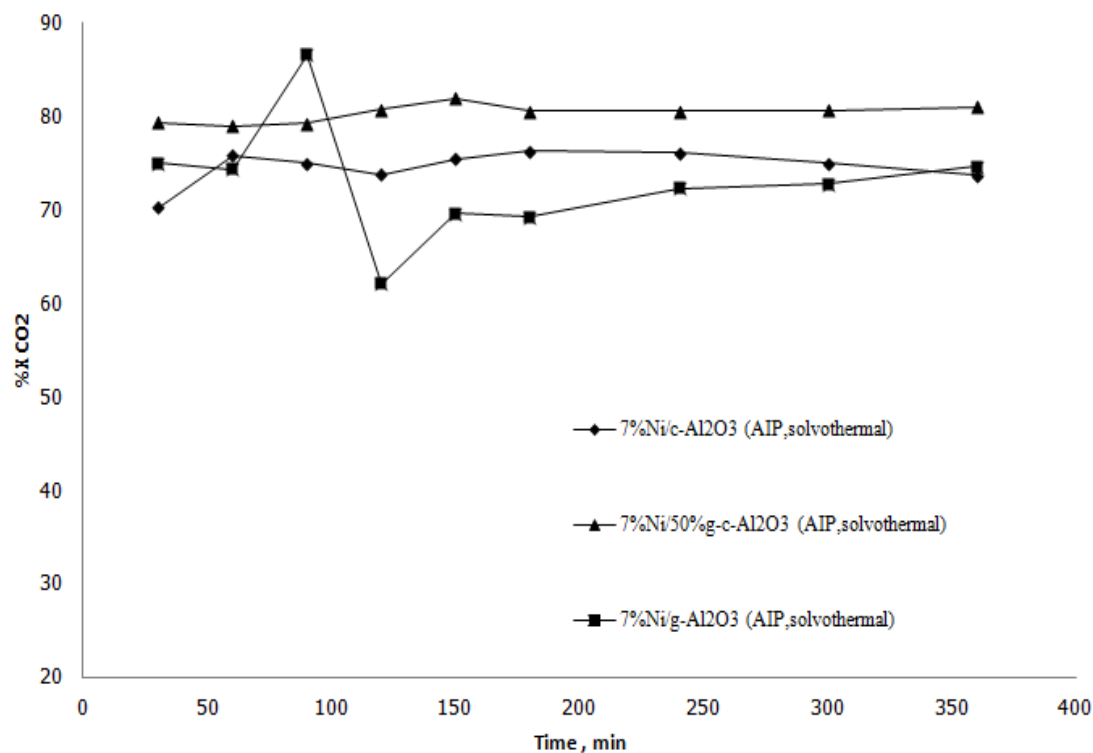

Figure 5.5 The effect of supported-nickel catalyst on the conversion of CO₂.

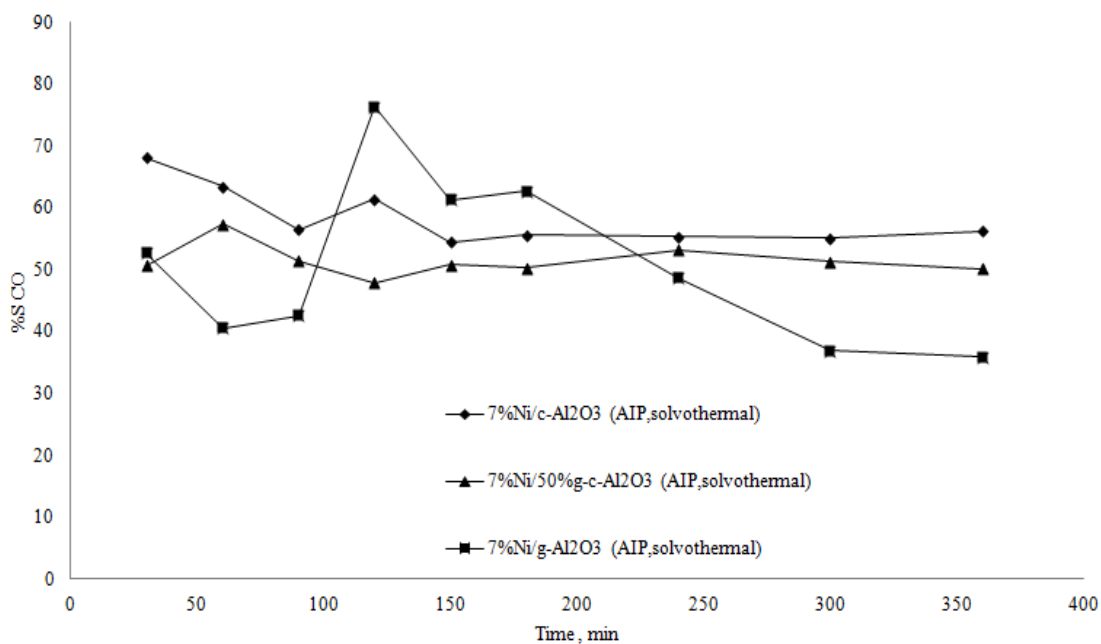

Figure 5.6 The effect of supported-nickel catalyst on the Selectivity of CO.

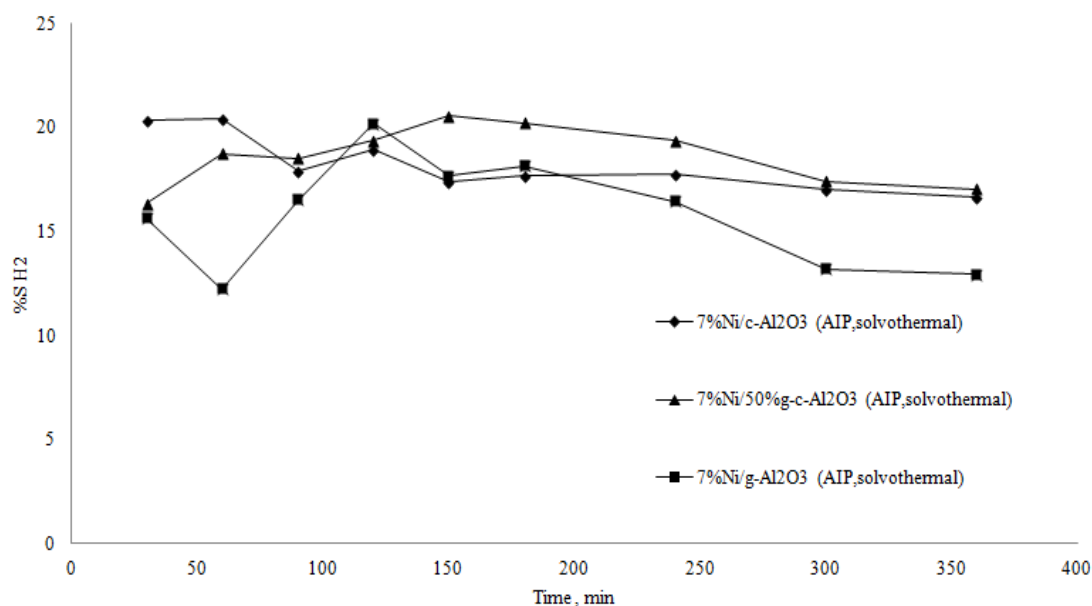

Figure 5.7 The effect of supported-nickel catalyst on the Selectivity of H₂.

The effect of preparation of alumina was shown in Figure 5.8, 5.9, 5.10 and 5.11 which consist of methane conversion, carbon dioxide conversion, selective of carbon monoxide and selective of hydrogen. The catalysts that used are γ -Al₂O₃ which prepared by difference methods and difference precursor. The result showed that 7%Ni/ γ -Al₂O₃ (AIP,solgel) gave the highest methane conversion among the other phases and also gave the highest hydrogen selective which are the main product of this reaction. Since 7%Ni/ γ -Al₂O₃ (AIP,solgel) had the highest active site that determined by CO chemisorptions. So the methane conversion depends on the active site of catalysts that was used in carbondioxide reforming of methane.

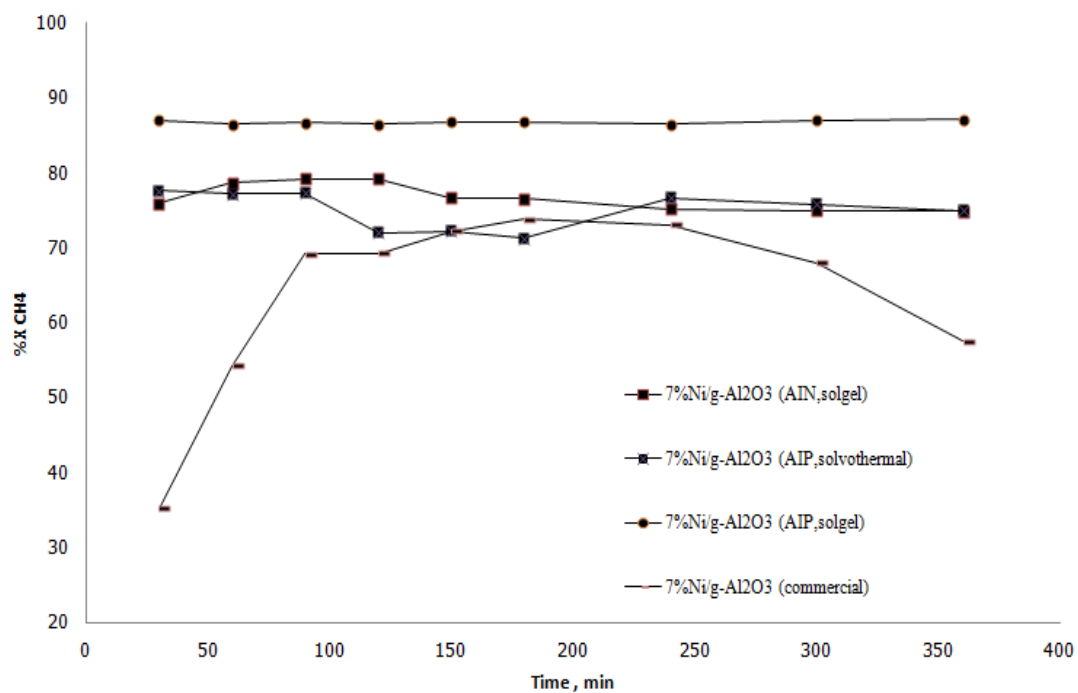

Figure 5.8 The effect of supported-nickel catalyst on the conversion of CH₄.

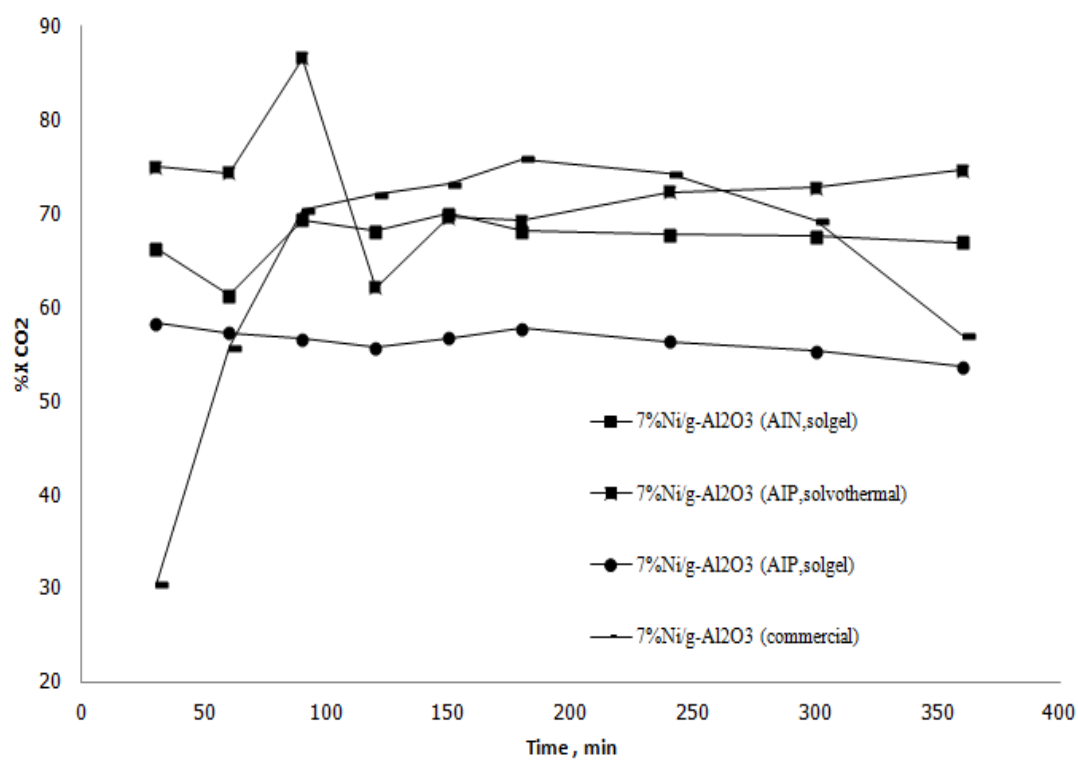

Figure 5.9 The effect of supported-nickel catalyst on the conversion of CO₂.

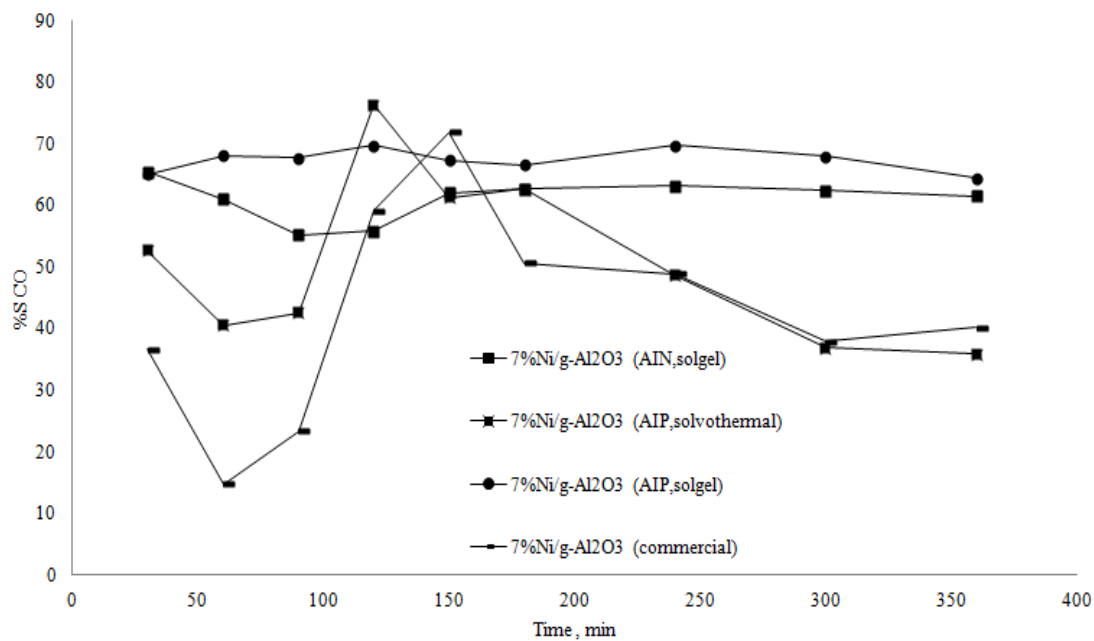

Figure 5.10 The effect of supported-nickel catalyst on the Selectivity of CO.

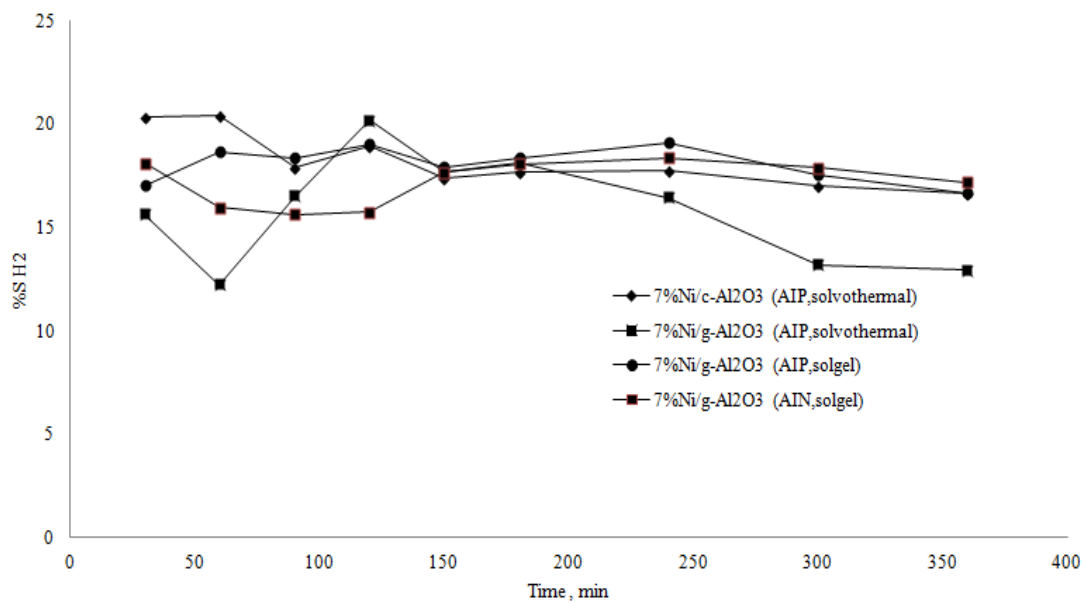

Figure 5.11 The effect of supported-nickel catalyst on the Selectivity of H₂.

The comparison of methane conversion for reforming reaction of methane by carbon dioxide over nickel catalyst on synthetic alumina and commercial γ -alumina are shown in Figure 5.12. The nickel catalyst on Ni/ γ -Al₂O₃ (AIP,solgel) gave the highest methane conversion of about 86% and 50% γ - χ -Al₂O₃ (AIP,solvothermal) gave a bit lower about 85%. While nickel catalyst on γ -Al₂O₃ (AIN,solgel), pure χ -alumina, pure γ -alumina and commercial γ -alumina gave methane conversion approximately 79%, 78%,76% and 69% respectively. Because 7%Ni/ γ -Al₂O₃ (AIP,solgel) had the highest active site that determined by CO chemisorptions. So the methane conversion depends on the active site of catalysts that was used in carbondioxide reforming of methane.

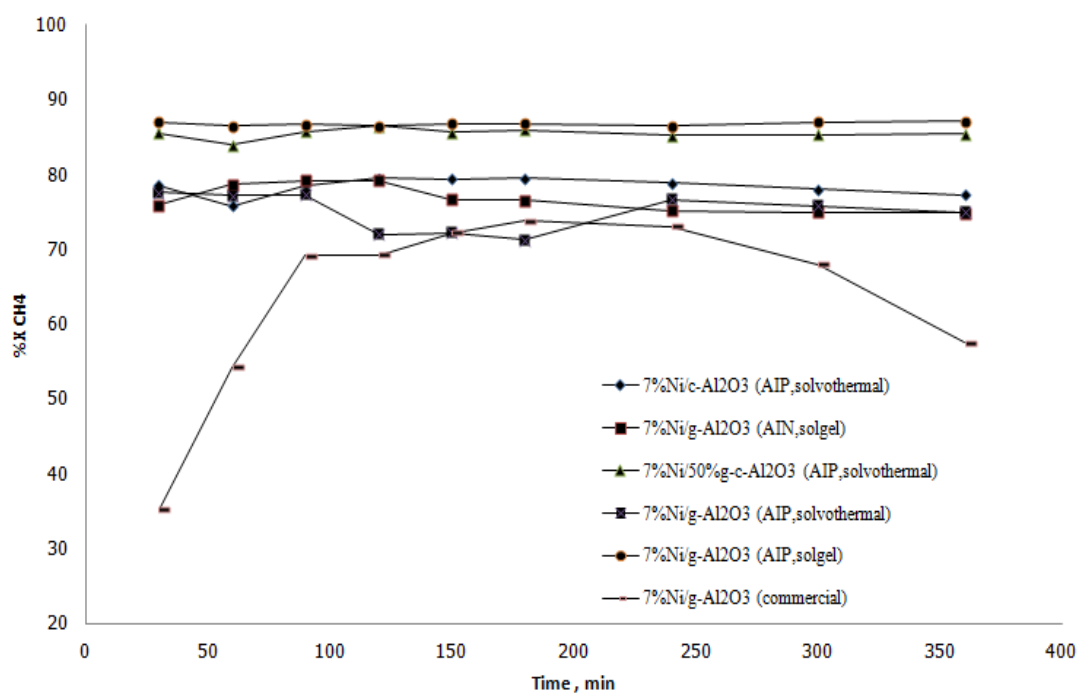

Figure 5.12 The effect of supported-nickel catalyst on the conversion of CH₄.

The comparison of carbondioxide conversion for reforming reaction of methane by carbon dioxide over nickel catalyst on synthetic alumina and commercial γ -alumina are shown in Figure 5.13. The nickel catalyst on 50% γ - χ - Al_2O_3 (AIP,solvothermal) gave the highest carbondioxide conversion of about 77% and conversion of pure χ -alumina are lower about 73%. And Figure 5.14 shows the selective of H_2 depend on supports catalysts, we found that 50% γ - χ - Al_2O_3 (AIP,solvothermal) gave the highest selective of hydrogen and commercial γ -alumina gave the lowest. The selective of CO was calculated and showed in Figure 5.15, Ni/ γ - Al_2O_3 (AIP,solgel) gave highest and commercial γ -alumina gave the lowest.

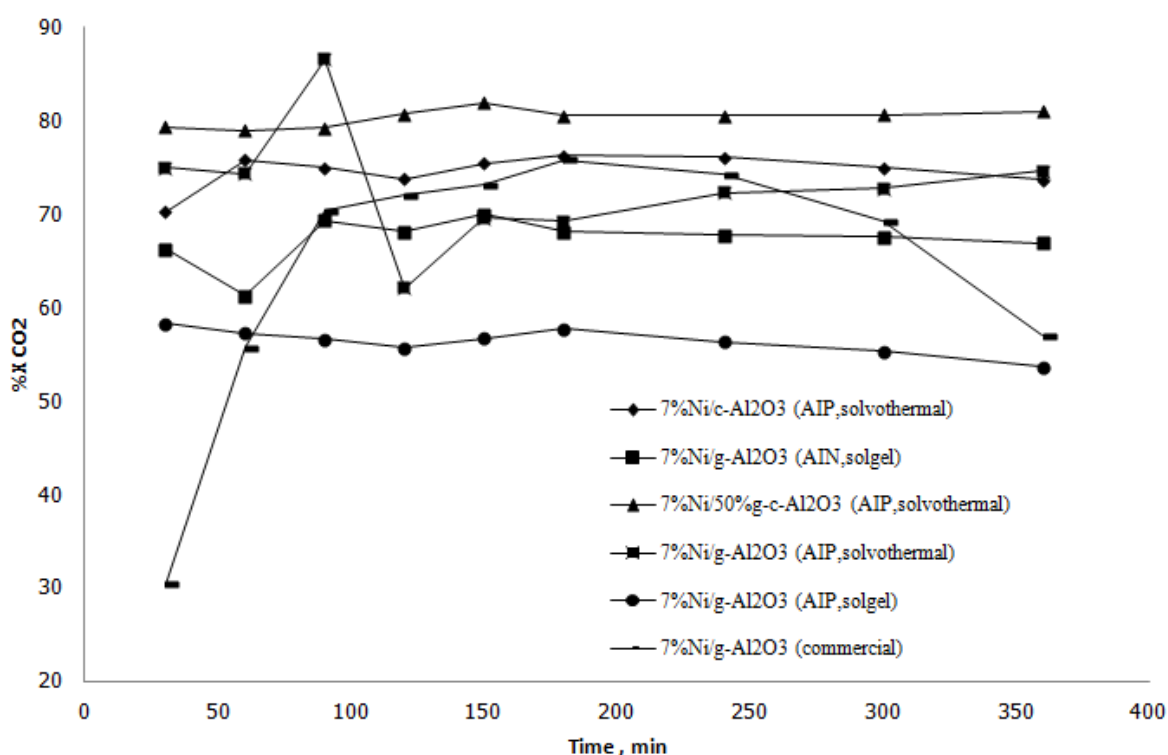

Figure 5.13 The effect of supported-nickel catalyst on the conversion of CO_2 .

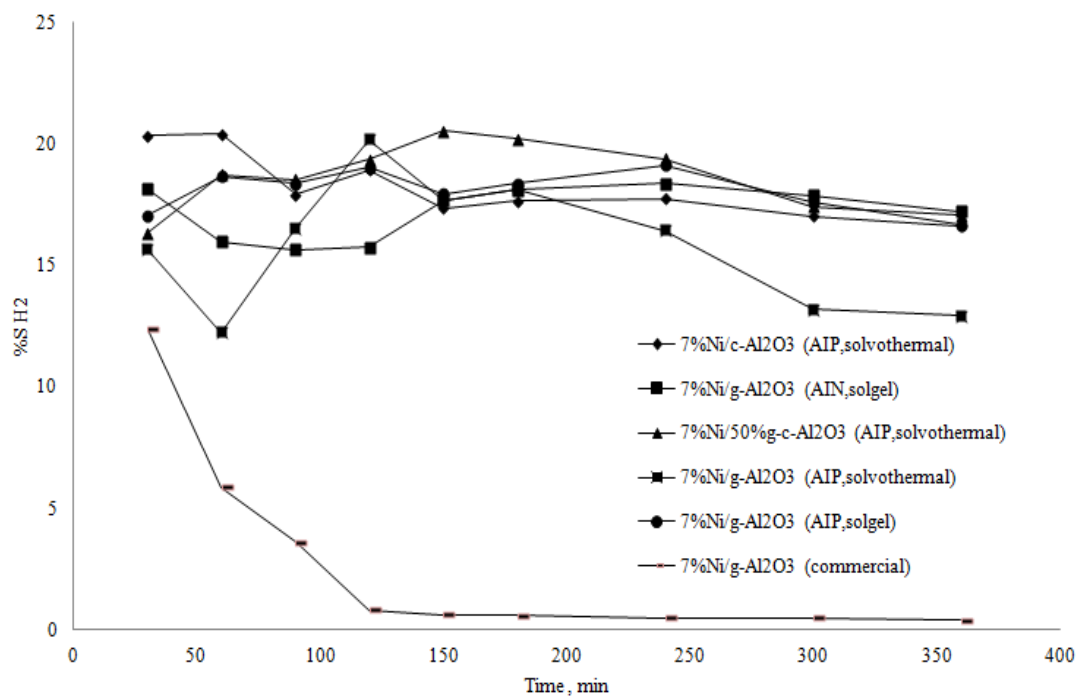

Figure 5.14 The effect of supported-nickel catalyst on the Selective of H₂.

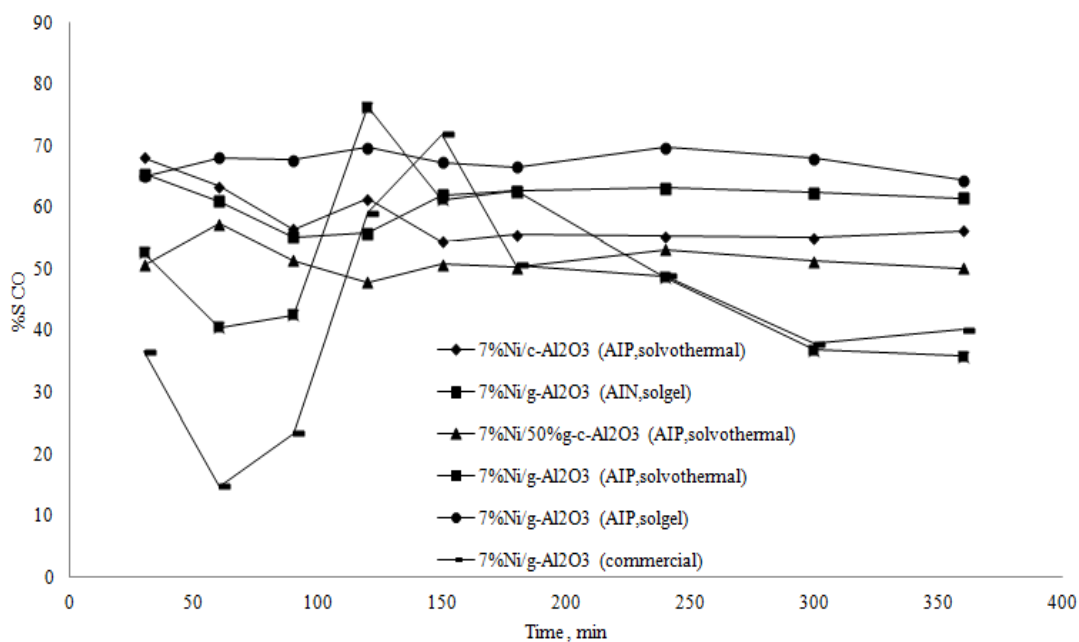

Figure 5.15 The effect of supported-nickel catalyst on the Selective of CO.

5.1.2.2 Reaction study of amount of Nickel supported on catalysts.

The comparison of methane conversion for reforming reaction of methane by carbon dioxide over nickel catalyst on synthetic alumina was prepared by sol-gel method is shown in Figure 5.16. The catalyst with Ni loaded 7% wt gave the highest methane conversion of about 86% and the catalyst with Ni loaded 10% wt gave a little lower about 84%. And the catalyst with Ni loaded 5% wt hardly reacted.

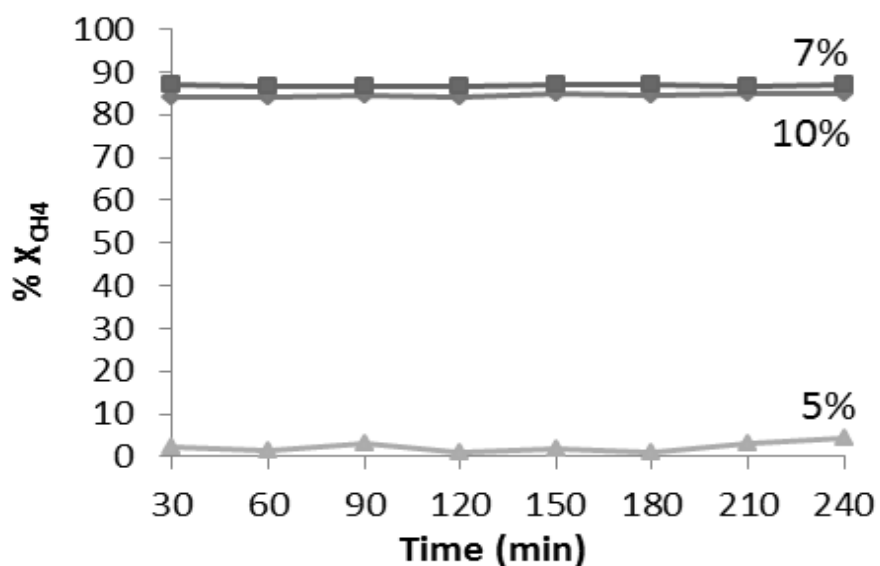

Figure 5.16 The effect of amount of nickel on catalyst on the conversion of CH₄.

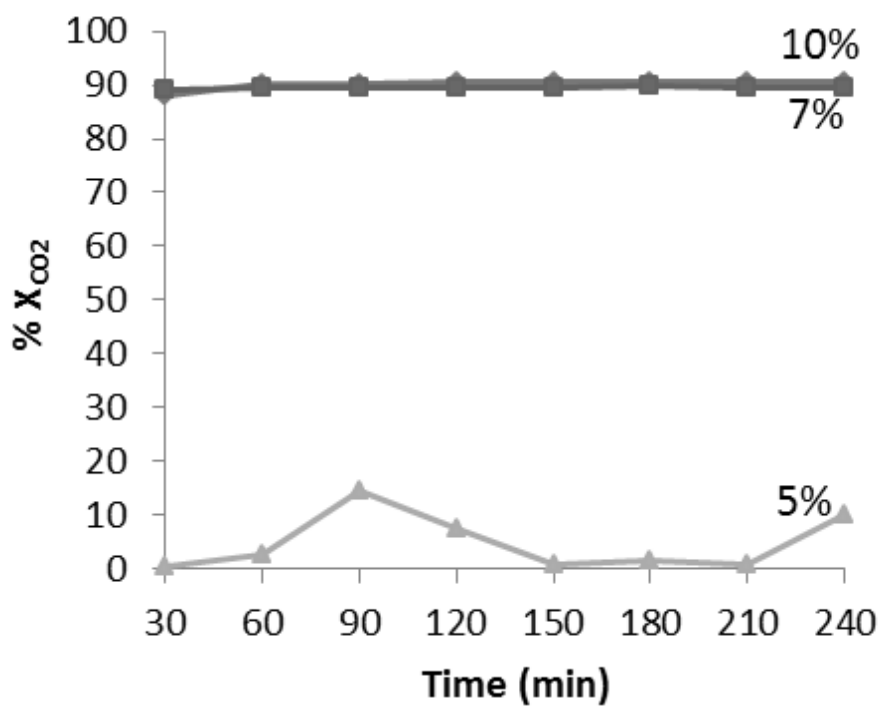

Figure 5.17 The effect of amount of nickel on catalyst on the conversion of CO₂.

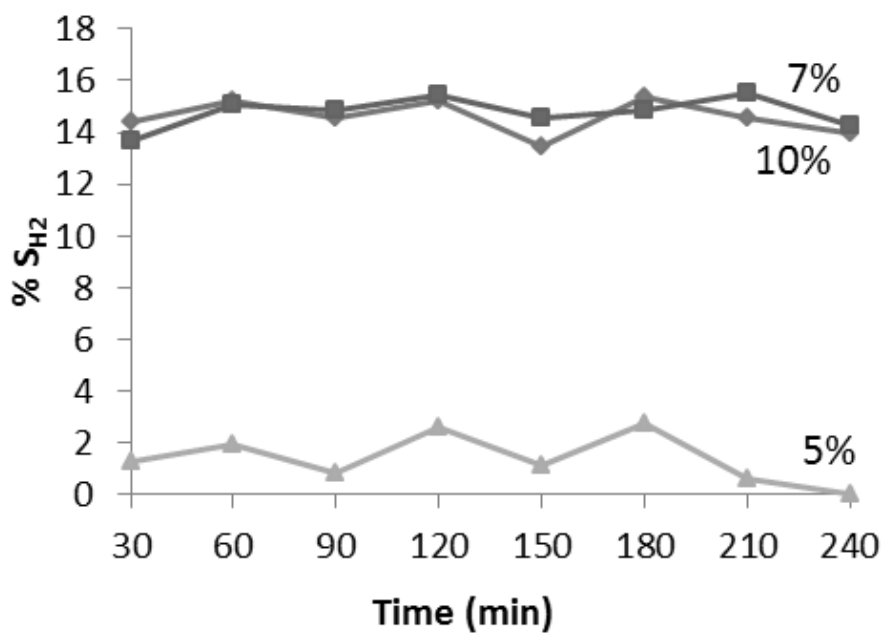

Figure 5.18 The effect of amount of nickel on catalyst on the selectivity of H₂.

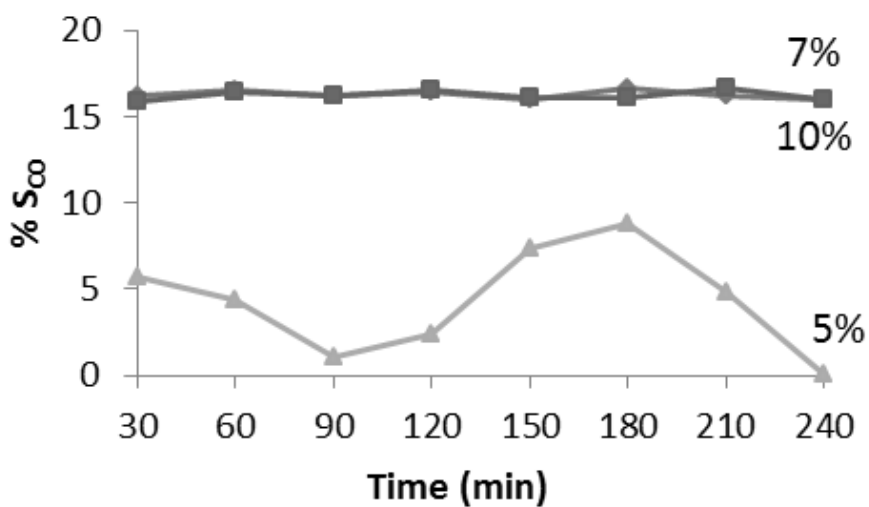

Figure 5.19 The effect of amount of nickel on catalyst on the selectivity of CO.

The comparisons of carbondioxide conversion for reforming reaction of methane by carbon dioxide over nickel catalyst are shown in Figure 5.16. The catalyst with 7% and 10% wt Nickel gave the highest carbondioxide conversion of about 89%-90% and conversion of 5% wt are lowest 0.3%-15%. And Figure 5.18 shows the selective of H₂ depend on amount of Nickel on catalysts, we found that the catalyst with 7% and 10% wt Nickel the highest selective of hydrogen about 13%-15% and 5% wt are lowest 0.3%-5%. The selective of CO was calculated and showed in Figure 5.19 the catalyst with 7% and 10% wt Nickel gave highest about 16% and 5% wt gave the lowest about 0.5%-9%.

5.1.2.3 Reaction study of additional of water in feed.

The comparison of methane conversion for reforming reaction of methane by carbon dioxide over nickel catalyst on synthetic alumina is shown in Figure 5.20. The result after addition of water into feed steam, the conversion went to a litter higher than feed steam without water. As a consequence, M. Simeone, 2007 found that catalyst deactivation and coke formation were estimated by measuring temperature distribution in catalyst bed.

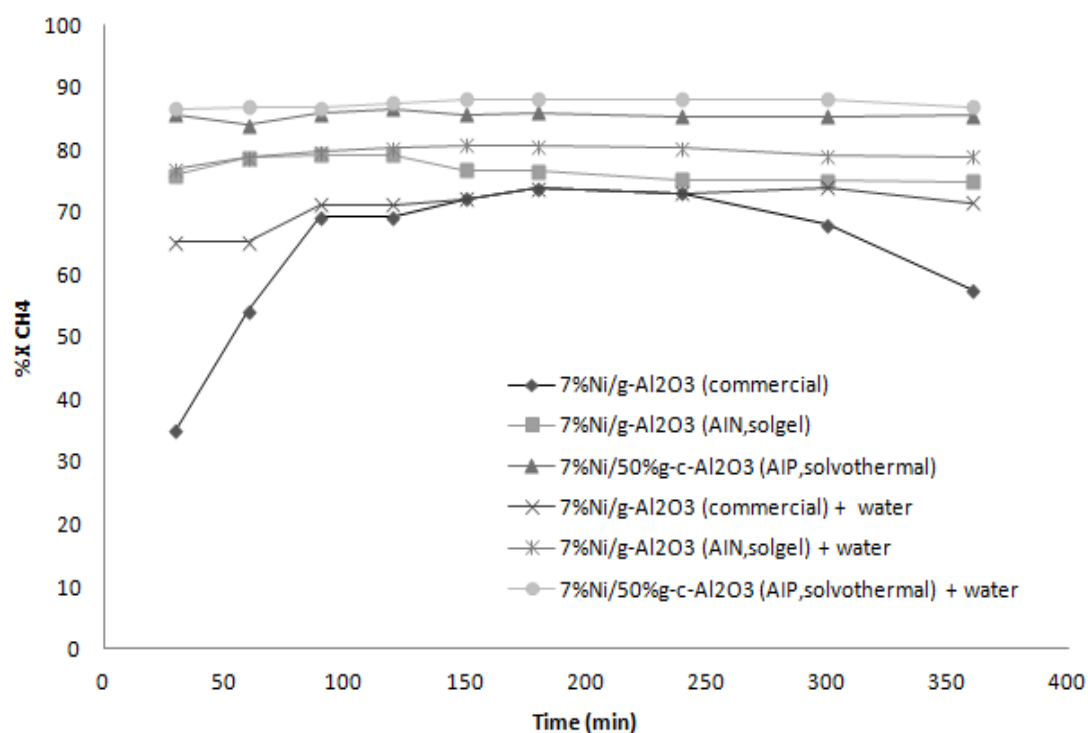

Figure 5.20 The effect of additional of water on the conversion of CH₄.

5.1.3 Morphology

Scanning Electron Microscopy (SEM) characterized the morphology was shown in Figure.5.21-5.34, the SEM images of fresh catalyst and used catalysts. And many filament carbon species was observed on used catalyst.

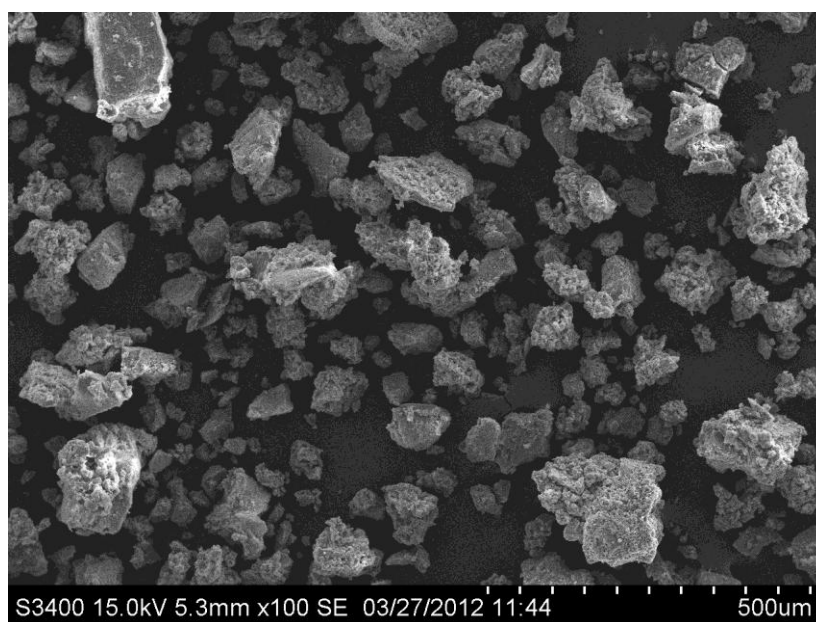

Figure 5.21 The SEM images of fresh 7%Ni/ γ -Al₂O₃ (commercial)

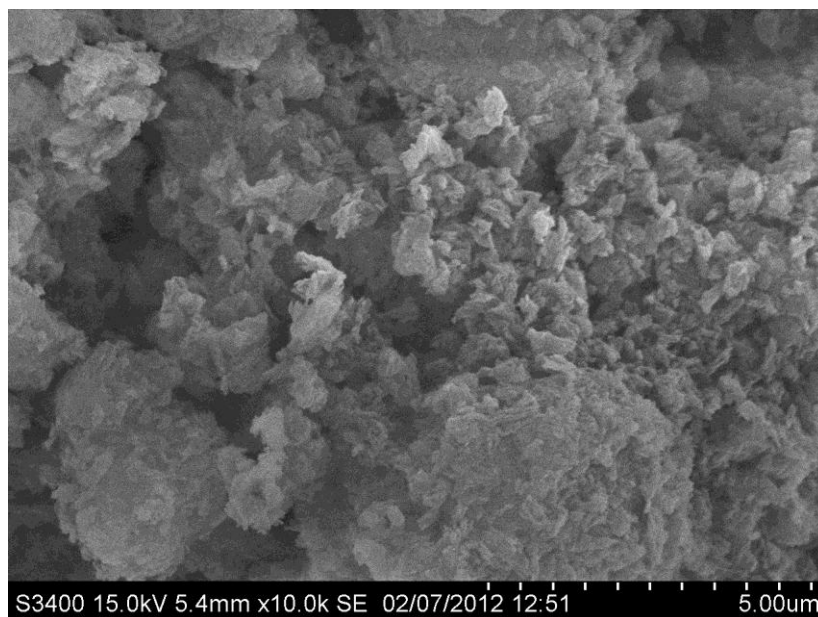

Figure 5.22 The SEM images of fresh 7%Ni/γ-Al₂O₃ (AIP,solvothermal)

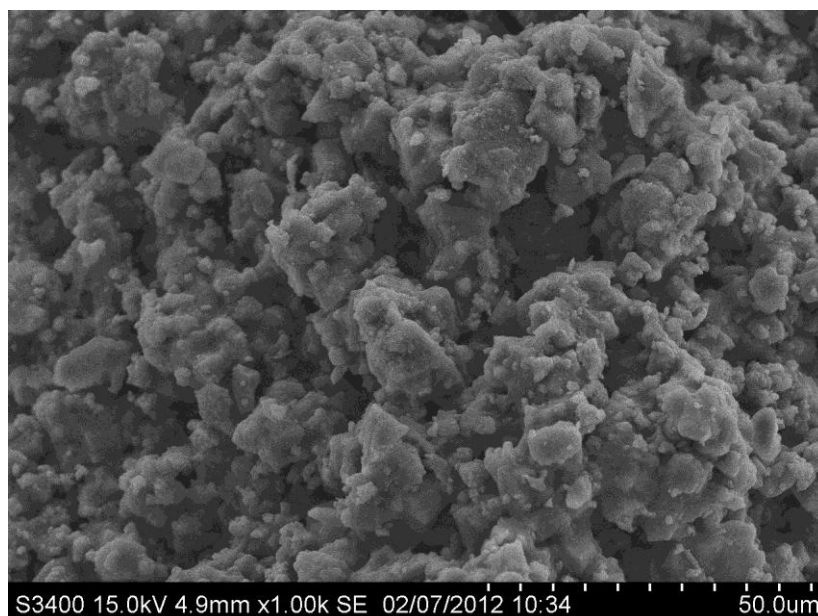

Figure 5.23 The SEM images of fresh 7%Ni/γ-Al₂O₃ (AIN,solgel)

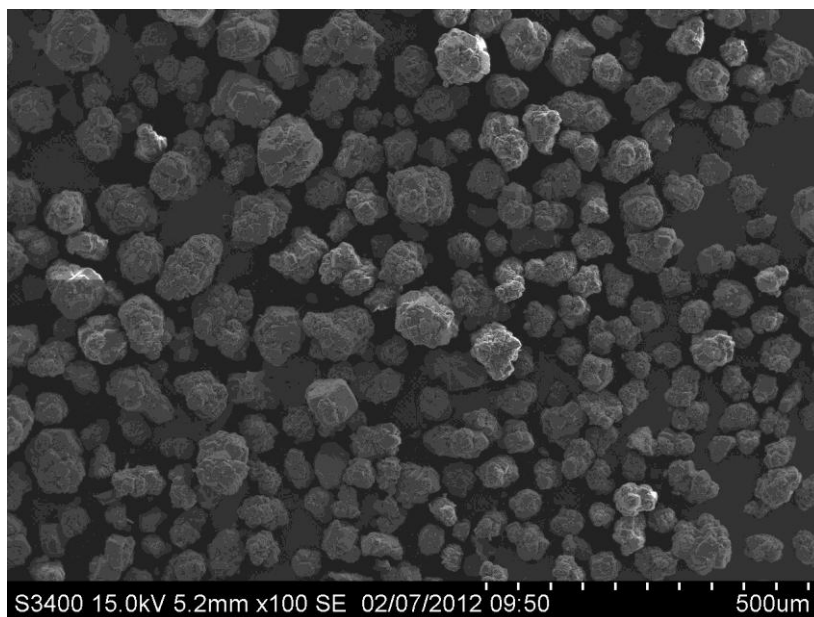

Figure 5.24 The SEM images of fresh 7%Ni/ γ -Al₂O₃ (AIP,solvothermal)

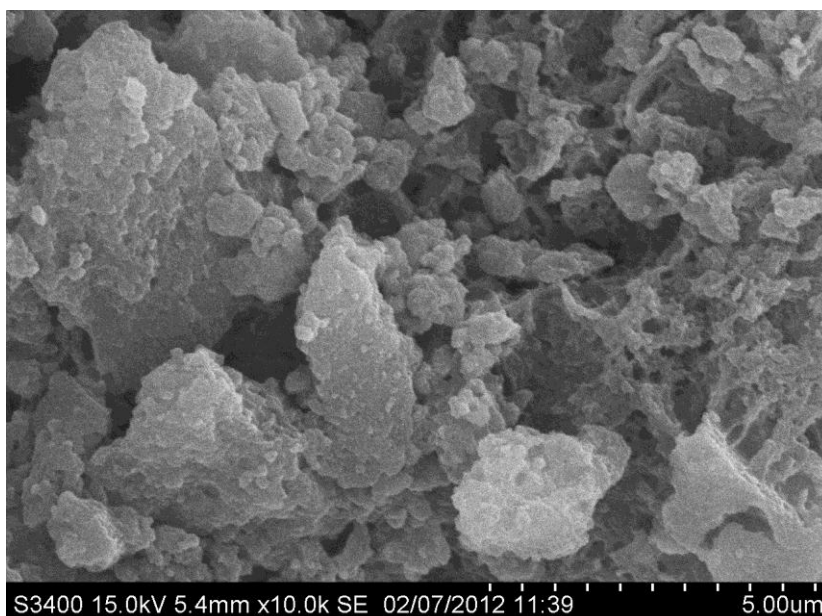

Figure 5.25 The SEM images of fresh 5%Ni/ γ -Al₂O₃ (AIP,solgel)

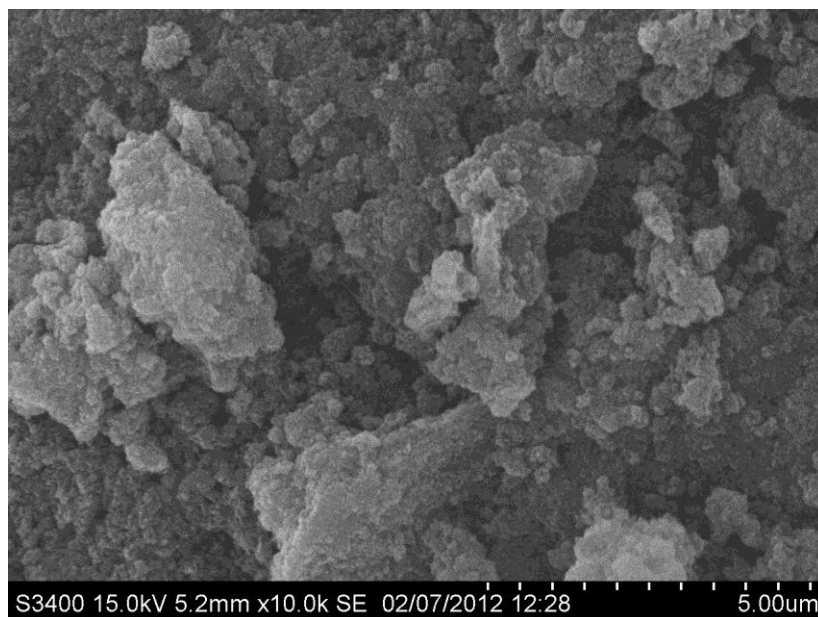

Figure 5.26 The SEM images of fresh 7%Ni/ γ -Al₂O₃ (AIP,solgel)



Figure 5.27 The SEM images of fresh 10%Ni/ γ -Al₂O₃ (AIP,solgel)

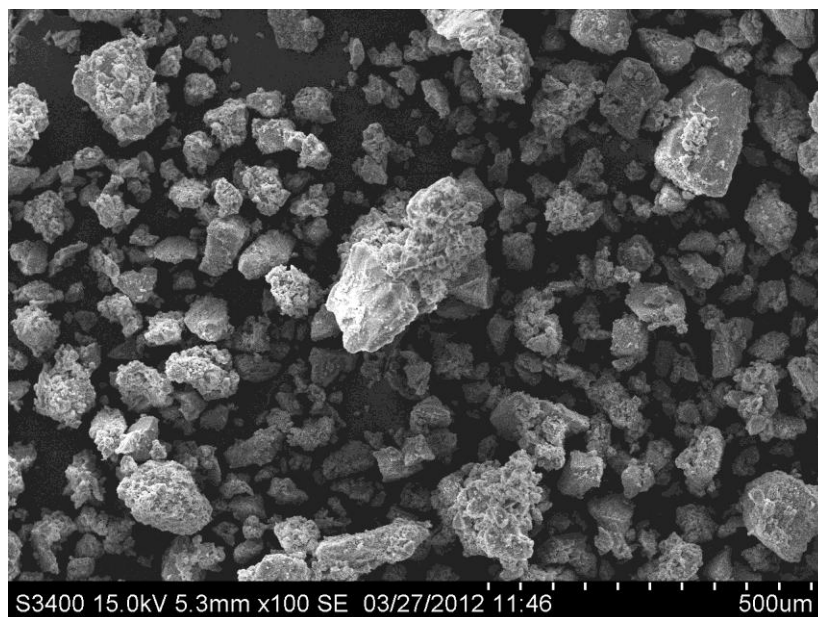

Figure 5.28 The SEM images of fresh 7%Ni/50% γ - γ -Al₂O₃ (AIP, solvothermal)

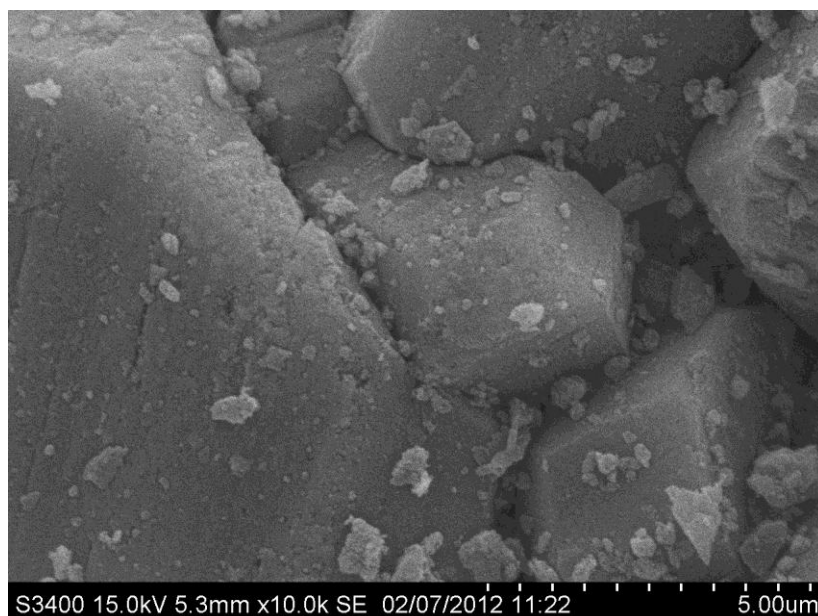

Figure 5.29 The SEM images of used 7%Ni/ γ -Al₂O₃ (commercial)

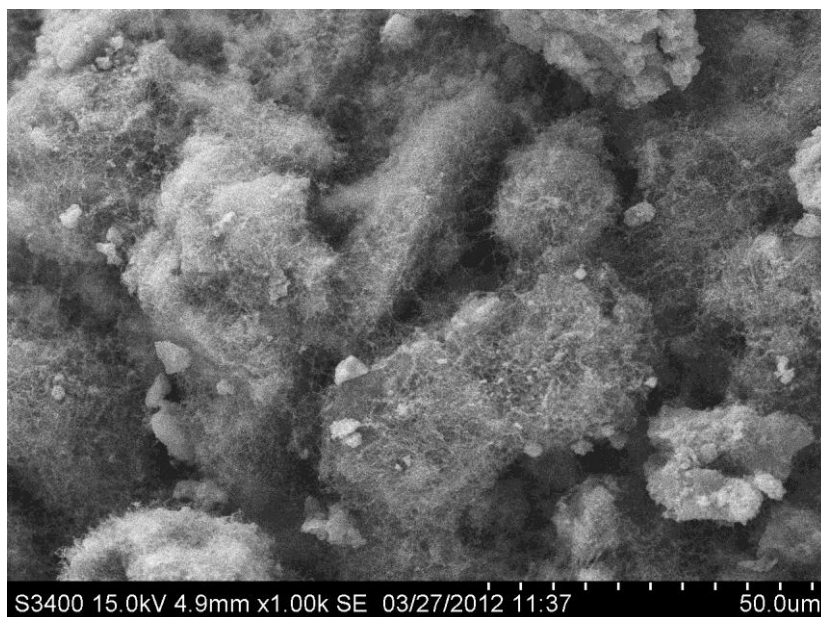

Figure 5.30 The SEM images of used 7%Ni/ γ -Al₂O₃ (AIP,solvothermal)

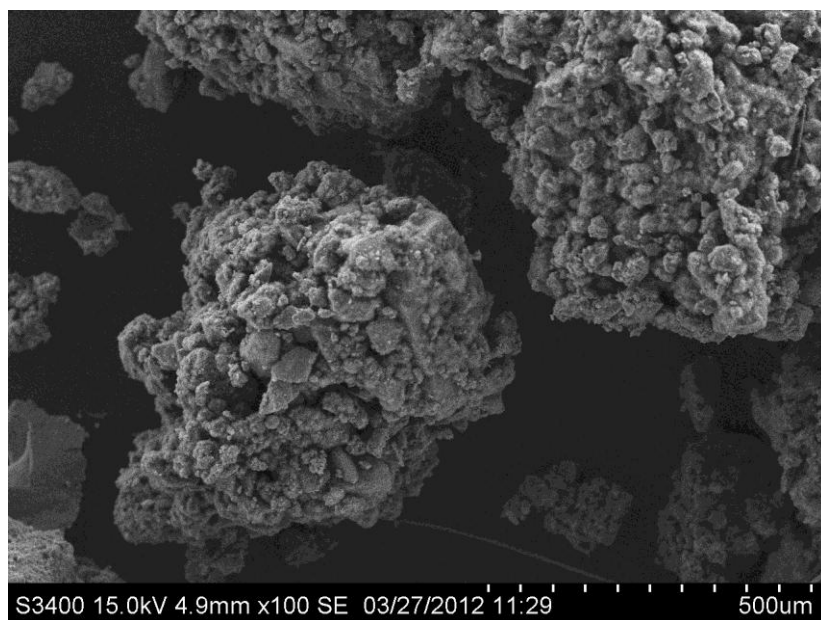

Figure 5.31 The SEM images of used 7%Ni/50% γ - χ -Al₂O₃ (AIP,solvothermal)

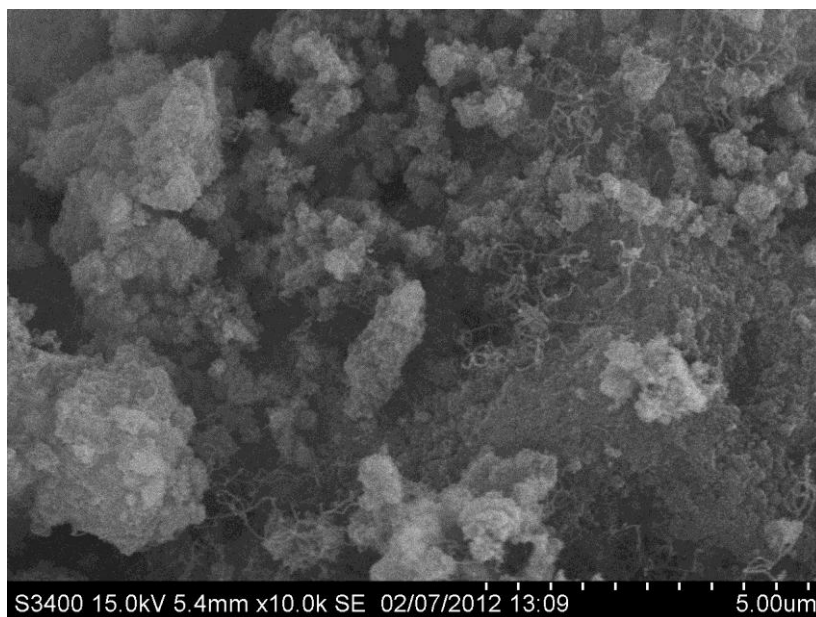

Figure 5.32 The SEM images of used 7%Ni/γ-Al₂O₃ (AIP,solvothermal)

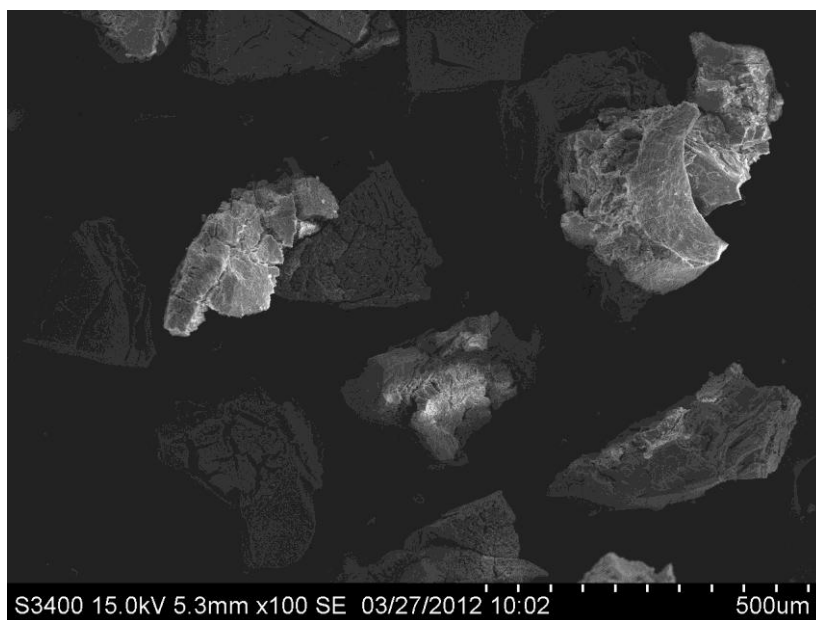

Figure 5.33 The SEM images of used 7%Ni/γ-Al₂O₃ (AIP,solgel)

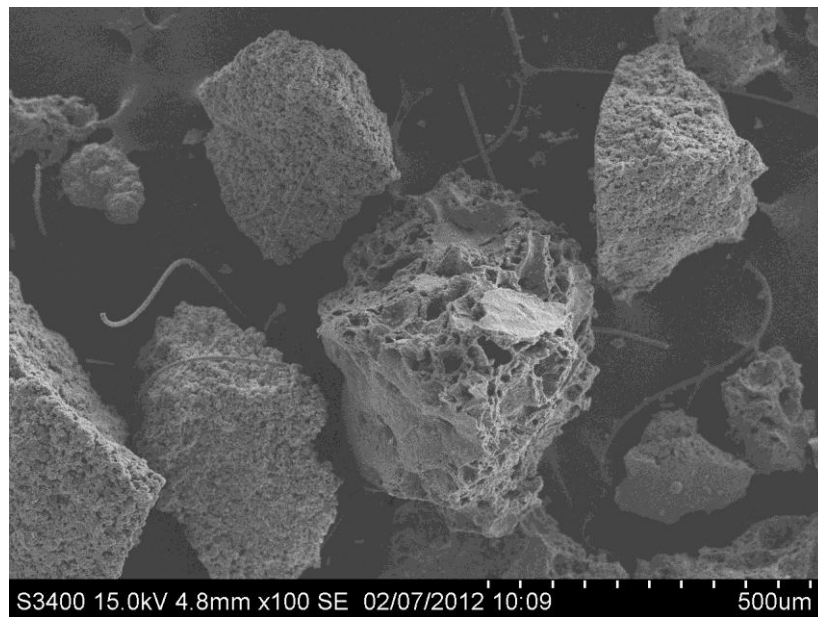

Figure 5.34 The SEM images of used 7%Ni/ γ -Al₂O₃ (AlN,solgel)

5.1.4 Amount of coke

Thermogravimetric and differential thermal analysis (TG-DTA) was determined amount of coke in catalysts. Figure 5.35 shows the comparison of the percent conversion difference of methane and carbon dioxide ($\%X_{CO_2} - \%X_{CH_4}$) in each catalysts, the result was as follow: $\gamma\text{-Al}_2\text{O}_3$ (AIP,solgel) < 50% γ - χ - Al_2O_3 (AIP,solvothermal) < $\gamma\text{-Al}_2\text{O}_3$ (AIN,solgel) < $\chi\text{-Al}_2\text{O}_3$ (AIP,solvothermal) < $\gamma\text{-Al}_2\text{O}_3$ (AIP,solvothermal) < and commercial $\gamma\text{-Al}_2\text{O}_3$, respectively. The graph of the percent weight loss versus temperature results in all catalysts loss weight during the temperature of 400-600 °C. Koo and co-worker (2008) found that corresponds to the coke decomposition on catalyst surface. This reaction has water as byproduct. And amount of water depend on the conversion difference of carbon dioxide and methane, which occurred in side reaction of carbon dioxide such as reverse water gas shift reaction.

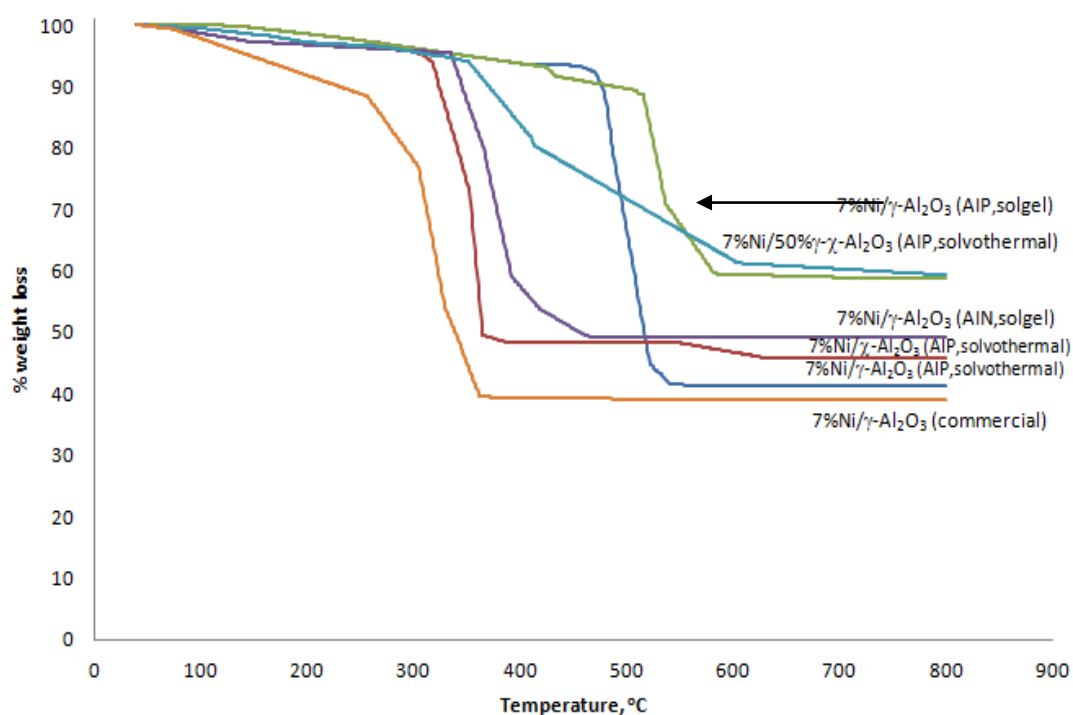

Figure 5.35 The weight loss of used catalysts in range of 10 – 800 °C

CHAPTER VI

CONCLUSIONS AND RECOMMENDATIONS

6.1 Conclusions

Reforming reaction of methane by carbon dioxide using synthetic of Nickel catalyst supported Alumina, 7%Ni/ γ -alumina catalyst which prepared by sol-gel method and using AIP as precursor gave the highest methane conversion and the highest conversion as well as the highest coke resistance of all the catalysts studied. The Amount of Nickel loaded on alumina support that gave the highest conversion of methane was 7% weight of Nickel. And it gave conversion of methane a little bit higher when addition of water into feed steam because of water decreasing deactivation, coke formation and temperature distribution in catalyst bed.

6.2 Recommendations

Recommendations for the future work are the following:

1. To study the effect of temperature of reaction and stability of catalyst.
2. To determine type of acidity (Bronsted and Lewis) with Fourier Transform Infrared Spectrophotometer (FTIR) for synthetic alumina.
3. To study interaction of nickel catalyst on synthetic alumina by X-Ray photoelectron spectroscopy.
4. To study the effect of various metals supported on catalyst, i.e. Mo and Pt.
5. To study the effect of synthetic titania and/or zirconia..
6. To study the effect of amount of water in feed steam.

REFERENCES

- Adolfo E. Castro Luna, María E. Iriarte. Carbon dioxide reforming of methane over a metal modified Ni-Al₂O₃ catalyst. Applied Catalysis A: General Volume 343, Issues 1-2, 1 July 2008, Pages 10-15
- Beychok, M.R., Coal gasification and the Phenosolvan process, American Chemical Society 168th National Meeting, Atlantic City, September 1974
- Charienseri, S. Combined carbon dioxide reforming and partial oxidation of methane under periodic operation. Chulalongkorn University. Master's Thesis, Department of Chemical Engineering, Faculty of Engineering, Chulalongkorn University, 2007.
- C.J. Brinker, A.J. Hurd, P.R. Shurnk, J. Non Cryst. Solids 147 (1992) 424.
- Guo, J., Hou, Z., Gao, J., and Zheng, X. Syngas production via combined oxy-CO₂ reforming of methane over Gd₂O₃-modified Ni/SiO₂ catalyst in a fluidized-bed reactor. Fuel, (2007)
- Julian R.H. Ross. Natural gas reforming and CO₂ mitigation. Catalysis Today 100 (2005) :151–158
- Kaengsilalai, A., Luengnaruemitchai, A., Jitkarnka, S., and Wongkasemjit, S. Potential of Ni supported on KH zeolite catalysts for carbon dioxide reforming of methane. Journal of Power Sources 165, (2007): 347-352
- Kang, J.S., Kim, D.H., Lee, S.D., Hong, S.I., and Moon, D.J. Nickel-based tri-reforming catalyst for the production of synthesis gas. Applied Catalysis A: General 332, (2007): 153-158
- Khom-in, J. Synthesis of dimethylether (DME) from dehydration of methanol using γ -Al₂O₃ and γ - γ -Al₂O₃ catalysts. Master's Thesis, Department of Chemical Engineering, Faculty of Engineering, Chulalongkorn university, 2007
- M. Simeone, L. Salemme, D. Scognamiglio, C. Allouis, G. Volpicelli. Effect of water addition and stoichiometry on temperature profile in autothermal methane reforming reactor with Ni catalyst. International journal of hydrogen energy 33 (2008) 1252-1261

- Pawelec, B., Damyanova, S., Arishtirova, K., Fierro, J.L.G., and Petrov, L. Structural and surface features of PtNi catalysts for reforming of methane with CO₂. Applied Catalysis A: General 323, (2007): 188-201
- Seung-Moon Kim, Yun-Jo Lee, Jong Wook Bae, H.S. Potdar, Ki-Won Jun. Synthesis and characterization of a highly active alumina catalyst for methanol dehydration to dimethyl ether. Applied Catalysis A: General 348 (2008): 113–120
- Seyma Ozkera-Aydinoglu, A.Erhan Aksoylu. CO₂ reforming of methane over Pt-Ni/Al₂O₃ catalysts: Effect of catalyst composition, and water and oxygen addition to the feed. International journal of hydrogen energy 36 (2011) 2950-2959
- Shaobin Wang, G.Q. Lu. Reforming of methane with carbon dioxide over Ni/Al₂O₃ catalysts: Effect of nickel precursor. Applied Catalysis A: General 169 (1998): 271-280
- Solymosi, F. (1994) Catalytic reaction of methane with carbon dioxide over supported palladium. Applied Catalysis A, 108, 205–219.
- Tung Chun Yaw, Nor Aishah Saidina Amin. Preparation of unsupported alumina membrane by sol-gel techniques. Journal of Membrane Science 133 (1997) 145-150
- Vasant R. Choudhary, Kartick C. Mondal. CO₂ reforming of methane combine with steam or partial oxidation of methane to syngas over NdCoO₃ perovskite-type mixed metal-oxide catalyst. Applied Energy 83, (2006): 1024-1032
- Wang, H.Y., and Ruckenstein, E. Carbon dioxide reforming of methane to synthesis gas over supported rhodium catalysts: the effect of support. Applied Catalysis A: General 204, (2000): 143-152
- Wang, S., and Lu, G.Q.M. CO₂ reforming of methane on Ni catalysts: Effect of the support phase and preparation technique. Applied Catalysis B: Environmental 16, (1997): 269-277
- XiaoRong Huang*, GenLiang Meng, ZhongTao Huang, JianMing Geng. Preparation of unsupported alumina membrane by sol-gel techniques. Journal of Membrane Science 133, (1997): 145-150

Zhigang Hao, Qingshan Zhu, Zheng Jiang, Baolin Hou, Hongzhong Li.
Characterization of aerogel Ni/Al₂O₃ catalysts and investigation on their
stability for CH₄-CO₂ reforming in a fluidized bed. Fuel processing
technology 90, (2009): 113-121

APPENDICES

APPENDIX A

CALCULATIONS OF REACTION FLOW RATE

Sample of calculation

The used catalyst = 0.20 g

Pack catalyst into quartz reactor (inside diameter = 0.49 cm)

Volumetric flow rate = 100 ml/min

Determine the average high of catalyst bed = 1.46 cm, so that

$$\text{Volume of bed} = \pi(0.245)^2 \times 1.46 = 0.275 \text{ ml}$$

$$\text{GHSV} = \text{Volumetric flow rate}^1 / \text{Volume of bed}$$

$$\text{GHSV} = 100 \text{ (ml/ min)} / 0.275 \text{ ml}$$

$$\text{GHSV} = 363.64 \text{ min}^{-1}$$

$$\text{GHSV} = 363.64 \times 60 = 21818.18 \text{ h}^{-1}$$

At STP condition:

$$\text{Volumetric flow rate} = \text{Volumetric flow rate}^1 \times ((273.15+T) / (273.15))$$

Where T = room temperature

APPENDIX B

CALIBRATION CURVES

This appendix shows the calibration curves for calculation of composition of products in reforming reaction of methane by carbon dioxide over supported nickel catalysts. The main product of reforming reaction of methane is carbon monoxide, carbon dioxide, hydrogen and methane.

The Thermal Conductivity Detector (TCD), gas chromatography Shimadzu model 8A was used to analyze the concentration of product by using porapack-Q column.

Mole of reagent in y-axis and area reported by gas chromatography in x-axis are exhibited in the curves. The calibration curves of carbon monoxide, carbon dioxide, hydrogen and methane are illustrated in Figure B1-B4, respectively.

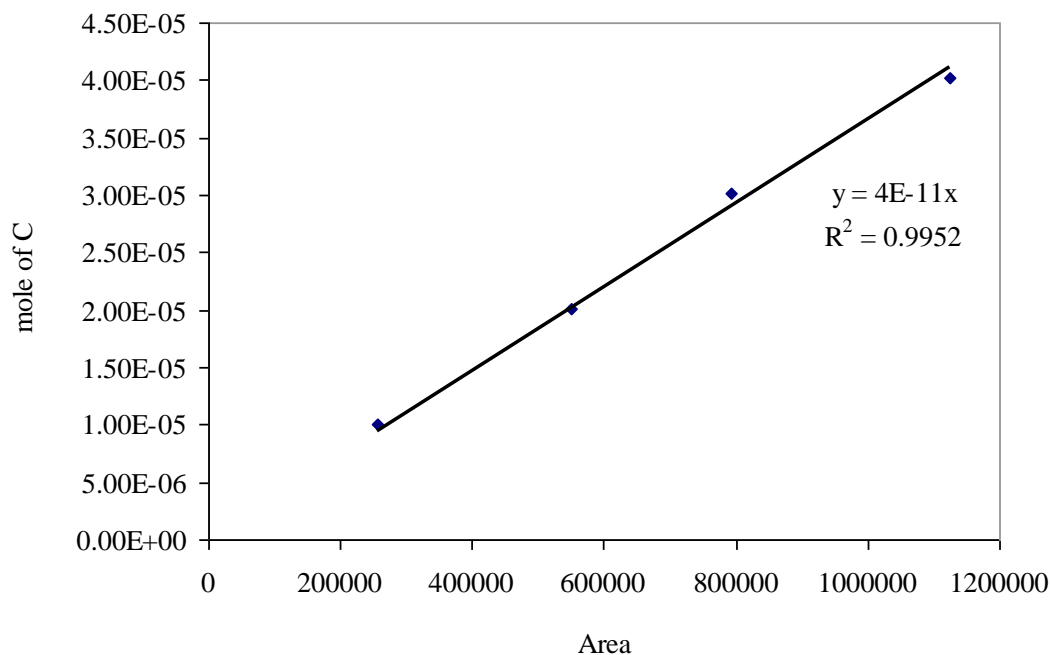

Figure B1 The calibration curve of carbon monoxide.

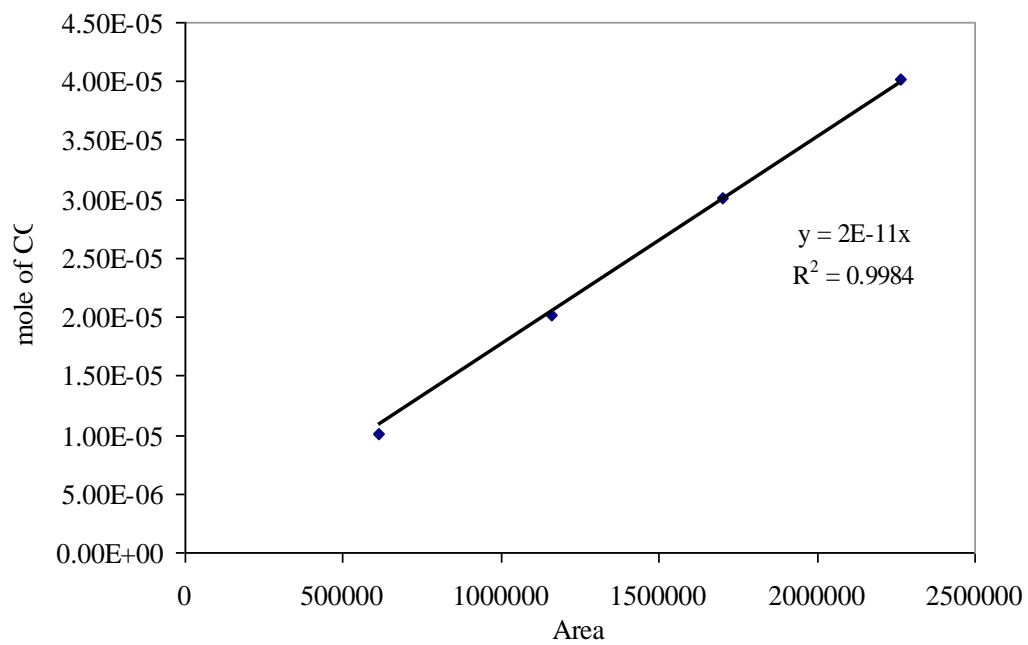

Figure B2 The calibration curve of carbon dioxide.

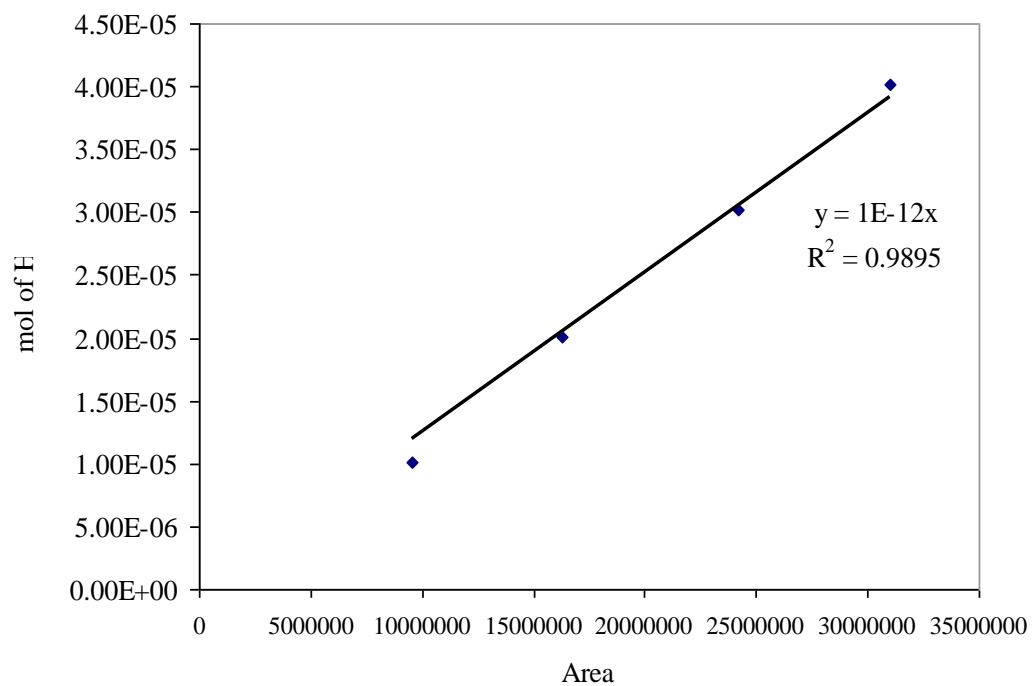

Figure B3 The calibration curve of hydrogen.

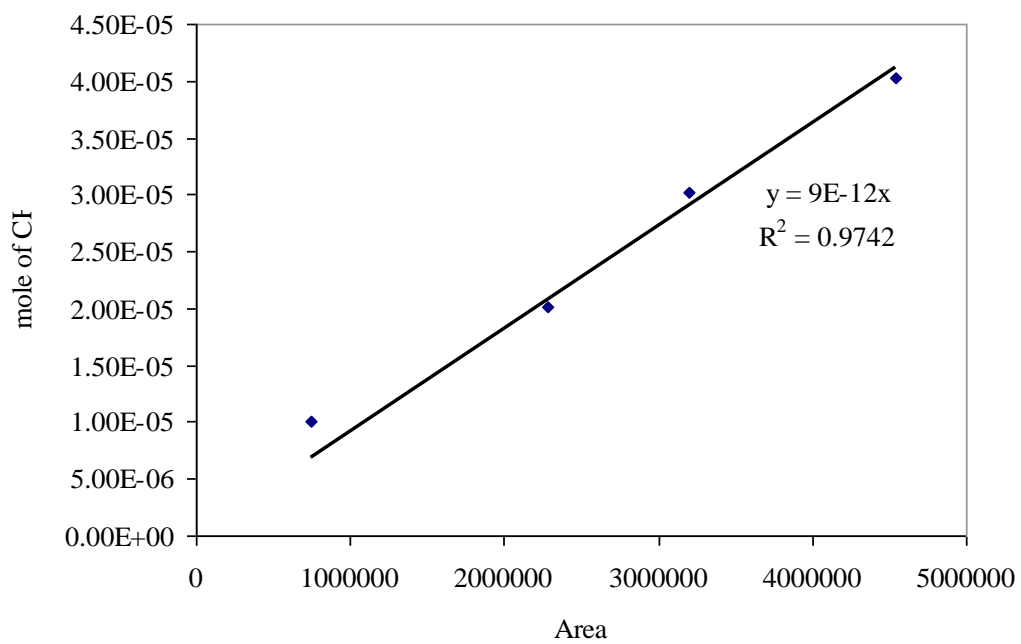

Figure B4 The calibration curve of methane.

APPENDIX C

CALCULATION FOR METAL ACTIVE SITES AND DISPERSION

Calculation of the total CO chemisorption and metal dispersion of the catalyst, a stoichiometry of CO/Ni = 1, is assumed. The calculation procedure is as follows:

| | | | |
|--|---|---|-----------------------------------|
| Let the weight of catalyst used | = | W | g |
| Integral area of CO peak after adsorption | = | A | unit |
| Integral area of 100 μ l of standard CO peak | = | B | unit |
| Amounts of CO adsorbed on catalyst | = | B-A | unit |
| Concentration of Ni | = | C | % wt |
| Volume of CO adsorbed on catalyst | = | $100 \times [(B-A)/B]$ | μ l |
| Volume of 1 mole of CO at 30 °C | = | 24.86×10^6 | μ l |
| Mole of CO adsorbed on catalyst | = | $[(B-A)/B] \times [100/24.86]$ | μ mole |
| Total CO chemisorption | = | $[(B-A)/B] \times [100/24.86] \times [1/W]$ | μ mole /g _{catalyst} |
| | = | N | μ mole /g _{catalyst} |

$$\% Ni \text{ dispersion} = \frac{\text{The amount of Nickel equivalent to CO adsorption after reduction} \times 100}{\text{Total amount of Nickel active sites expected to exist after reduction}}$$

| | | |
|----------------------------|---|---|
| Molecular weight of Nickel | = | 58.69 |
| Metal dispersion (%) | = | $\frac{1 \times Ni_{tot} \times 100}{No. \mu mole Ni_{tot}}$ |
| | = | $\frac{1 \times N \times 100}{No. \mu mole Ni_{tot}}$ |
| | = | $\frac{1 \times N \times 58.69 \times 100 \times 100}{[C \times 10^6]}$ |
| | = | $\frac{0.59 \times N}{C}$ |

APPENDIX D

DATA OF CALCULATION OF ACID SITE

Calculation of total acid sites

For example, TS-1 sample, total acid site is calculated from the following step.

1. Conversion of total peak area to peak volume

conversion from Micromeritics Chemisorb 2750 is equal to 77.5016 ml/area unit. Therefore, total peak volume is derived from

Example: 7%Ni/50% γ - χ -Al₂O₃ (AIP,solvothermal) catalyst give total peak area is 2.55975 area

$$\begin{aligned}\text{Total peak volume} &= 77.5016 \times \text{total peak area} \\ &= 77.5016 \times 0.5878 \\ &= 45.55 \text{ ml}\end{aligned}$$

2. Calculation for adsorbed volume of 15% NH₃

$$\begin{aligned}\text{adsorbed volume of 15\% NH}_3 &= 0.15 \times \text{total peak volume} \\ &= 0.15 \times 45.55 \text{ ml} \\ &= 6.833 \text{ ml}\end{aligned}$$

3. Total acid sites are calculated from the following equation

$$\text{Total acid sites} = \frac{(\text{Adsorbed volume, ml}) \times 101.325 \text{ Pa}}{\left(8.314 \times 10^{-3} \frac{\text{Pa} \cdot \text{ml}}{\text{K} \cdot \mu\text{mol}}\right) \times 298 \text{ K} \times (\text{weight of catalyst, g})}$$

For 7%Ni/50% γ - γ -Al₂O₃ (AIP,solvothermal) catalyst sample , 0.1001 g of this sample was measured, therefore

$$\begin{aligned} \text{Total acid sites} &= \frac{6.833 \text{ ml} \times 101.325 \text{ Pa}}{\left(8.314 \times 10^{-3} \frac{\text{Pa} \cdot \text{ml}}{\text{K} \cdot \mu\text{mol}} \right) \times 298 \text{ K} \times (0.1001 \text{ g})} \\ &= 2.78 \text{ mmol H}^+/\text{g}. \end{aligned}$$

APPENDIX E

CALIBRATION CURVE OF CHI PHASE PERCENT

This appendix showed the calibration curves for calculation of chi phase percent in alumina catalysts which derived from the XRD pattern of physical mixtures between pure γ - and χ - alumina with various contents.[Khom-in, 2007]

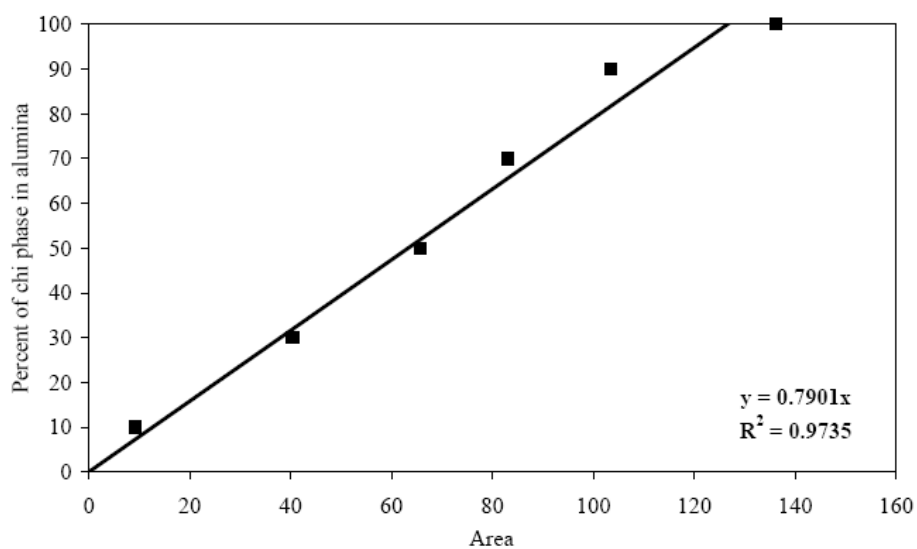

Figure E1 The calibration curve of chi phase percent in alumina.

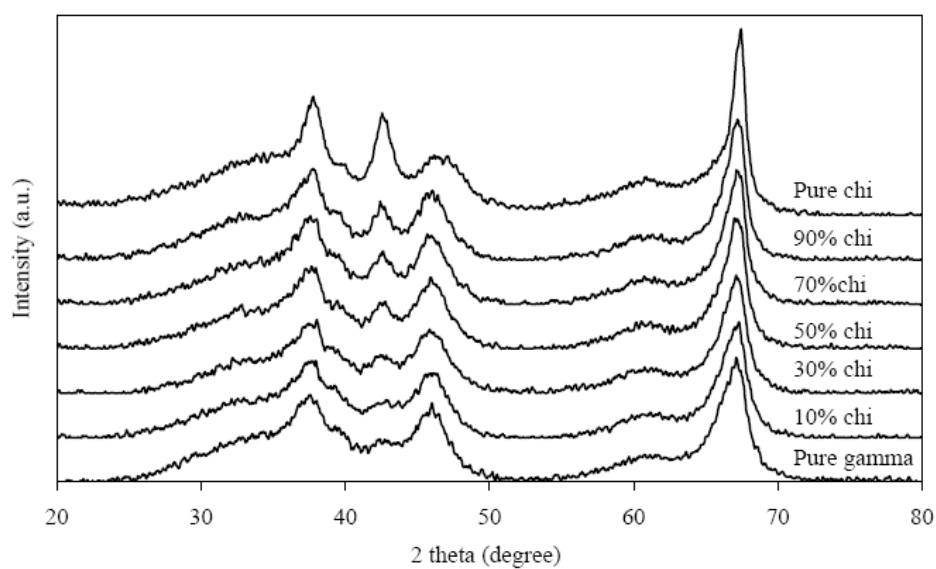

Figure E2 The XRD pattern of physical mixtures between pure γ - and χ - alumina with various contents

APPENDIX F

LIST OF PUBLICATION

Wanida Tanhakit, Suphot Phatanasri “Reforming reaction of methane by carbon dioxide over alumina-supported nickel catalysts”, Thailand Chemical Engineering and Applied Chemistry Conference (TICHE) International Conference 2011, Songkla, Thailand, Nov., 10-11, 2011.

VITA

Miss Wanida Tanhakit was born on May 11th, 1988 in Bangkok, Thailand. She finished high school from Sattasamut School in 2005, and received the bachelor's degree of Chemical Technology from Faculty of Science, Chulalongkorn University in 2009. She continued her master's study at Department of Chemical Engineering, Faculty of Engineering, Chulalongkorn University in June, 2010.