



## CHAPTER IV

### EXPERIMENTAL

The purpose of this experiment study could be separated into 2 parts : Study of the characteristics of UF, study of the cell recycling system. The details of the experimental investigation is presented as follow.

#### 4.1 Strain

The strain used in this study was Clostridium acetobutylicum ATCC 824 stored as liquid samples from non-pH regulated cultures at 0°C in glass tubes.

#### 4.2 Medium

The same medium was used for inoculum, batch and continuous cultures. It has been defined by Petitdemange; for 1L,  $K_2HPO_4$  0.5 g;  $KH_2PO_4$  0.5 g;  $MgSO_4 \cdot 7H_2O$  0.2 g;  $MnSO_4 \cdot H_2O$  0.01g;  $FeSO_4 \cdot 7H_2O$  0.01 g; NaCl 0.01 g; Yeast extract 6.0 g; D (+) Glucose anhydrous variable. For continuous fermentation, antifoam (vegetable oil) was added to the fermentation broth for reducing foam.

#### 4.3 Experimental Equipments

##### 4.3.1 Fermenter

4.3.1.1 Batch system : A KMJ-2B 3 litre glass fermentor from Mituwa Rikagaku kogyo Co., Japan was used for the batch system. The pH of the experimental fermentation broth was controlled by a pH controller which controlled an alkali feed pump. The temperature of the system was controlled at 35°C by a temperature controller.

4.3.1.2 Cell recycling system : a 2 litre glass fermentor was used for continuous fermentation. The volume of broth was controlled with a level controller which controlled the medium feed pump. The pH of total fermentation broth was controlled by the pH controller which controlled the alkali feed pump.

#### 4.3.2 The Cell Recycling System

The ultrafilter was a ceramic filter (type 1M-1, Japan) (figure 4.1) consisting of 19 carbon tubes with an ultrafiltering ceramic coat inside. The tubes were 4 mm in internal diameter, 85 cm long; and a  $0.2030 \text{ m}^2$  of filtration area. The pore diameter was  $0.2 \mu\text{m}$  (molecular weight cut off  $\sim 100,000$ ). A peristaltic pump was used for pumping the nutrient which was controlled by a level controller. The fermentation broth was circulated through the ultrafiltration module with a sanitary rotary pump (0.75 kW). The circulation velocity was 0.465 m/sec. The permeate was continuously discharged at a fixed flow rate  $Q$ , and collected in a storage tank. The excess permeate was directly recycled to the fermentor.

ศูนย์วิทยาศาสตร์  
จุฬาลงกรณ์มหาวิทยาลัย

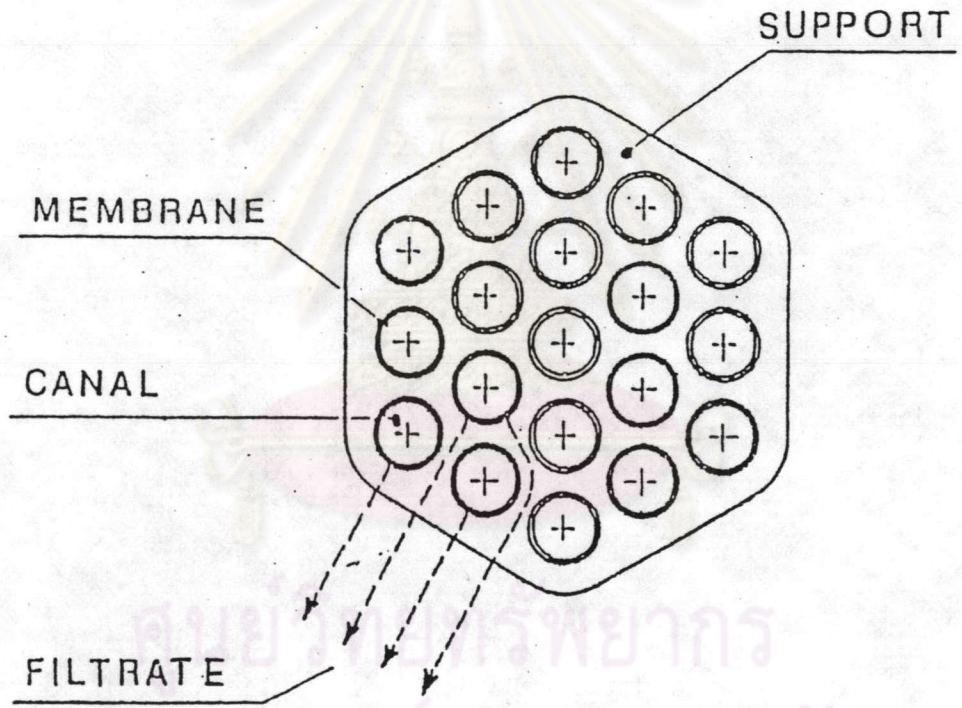
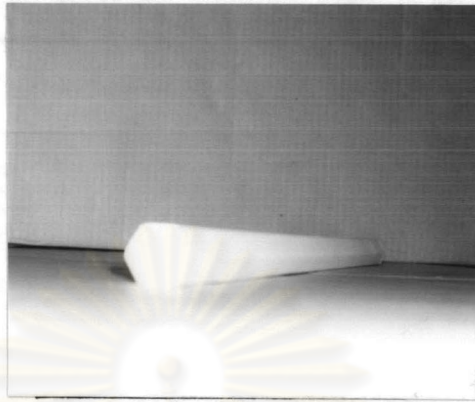

Figure 4.1 A ceramic filter (type 1M-1).

ศูนย์เทคโนโลยีทางการแพทย์  
จุฬาลงกรณ์มหาวิทยาลัย

#### 4.4 Experimental Procedure

##### 4.4.1 Study of the Characteristics of U.F. Membrane

The aim of this study was to find the optimum operating condition of this equipment for application in the cell recycling system. From ultrafiltration theory the parameters that effect filtration processes are temperature, pH, concentration of solute, recirculation velocity, and pressure. But pH and temperature in this study were fixed at the optimal point in fermentation process so the parameters studied were concentration of solute, pressure and recirculation velocity or recirculation flow rate.

##### 4.4.1.1 Membrane Cleaning

After operating every batchs the membrane was cleaned by rinsing and back flushing with deminaralized water so that residual proteins and other particles were removed. By this method, permeate flux will be restored. Membrane cleaning was terminated when the permeate flow rate of water is not less than the set point ( $11.5 \times 10^{-3} \text{ m}^3/\text{hr}$  at recirculation flow rate  $0.4 \text{ m}^3/\text{hr}$ , pressure  $0.0^+ \text{ kg}_f/\text{cm}^2$  temperature  $33.0^\circ\text{C}$ ).

##### 4.4.1.2 Experimental Set Up

The schematic of the U.F. system is shown in Figure 4.2. Fluid is removed from a process tank (1) by pumping through the ultrafiltration unit (6) and returned to the tank. The permeate flow rate is measured and then the permeate is returned to the process tank. The parameters (solute concentration, pressure, and recirculation flow rate) used for each experiments are shown in table 4.1.

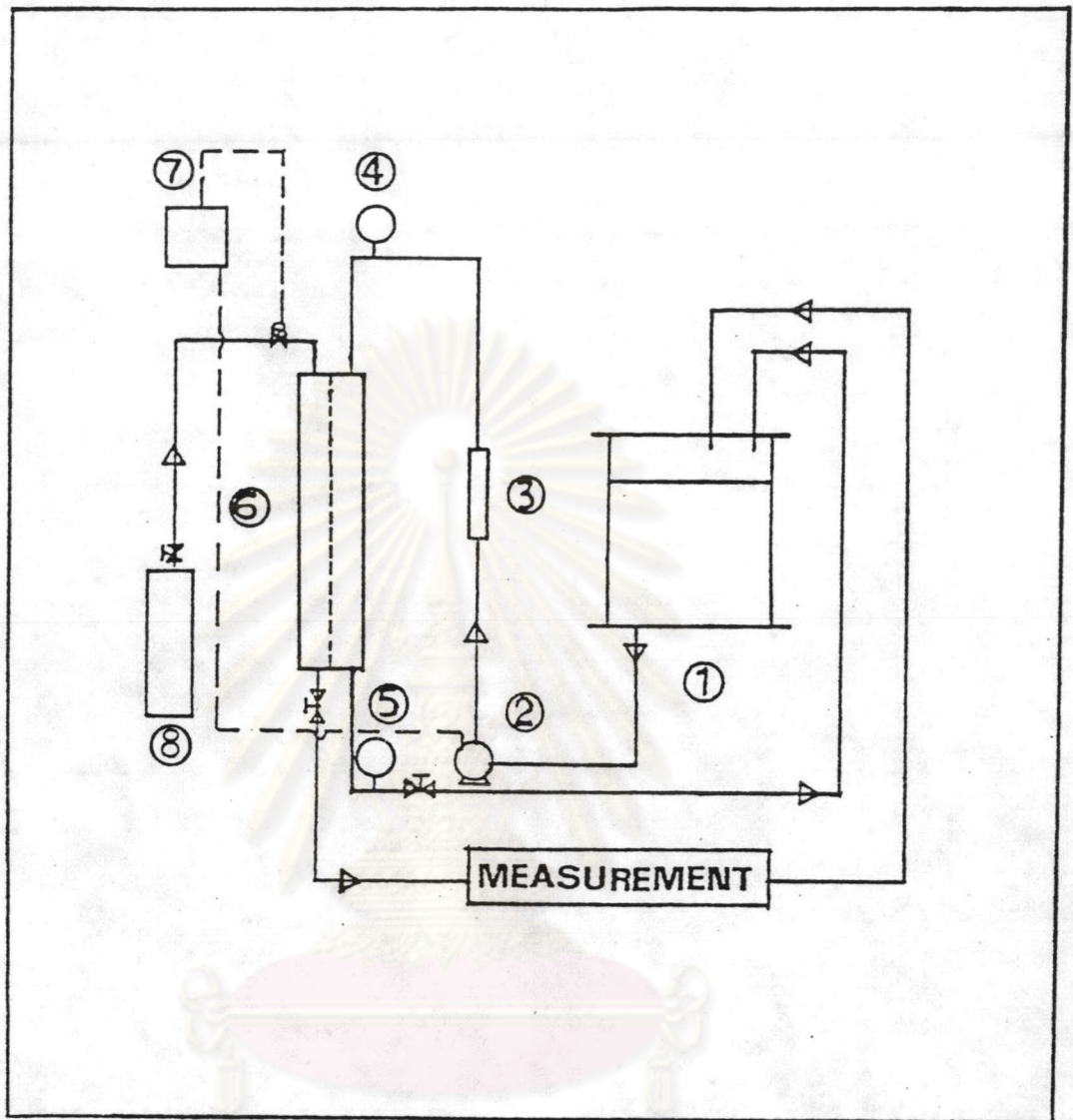

Figure 4.2 Schematic diagram of ultrafiltration system

- |                         |                                |
|-------------------------|--------------------------------|
| 1. process tank         | 5. outlet pressure gauge       |
| 2. recirculation pump   | 6. ultrafiltration membrane    |
| 3. flow meter           | 7. control block               |
| 4. inlet pressure gauge | 8. N <sub>2</sub> storage tank |

Table 4.1 The operation of ultrafiltration system for studying the effects of pressure, recirculation flow rate and biomass concentration on permeate flux.

RUN	TYPE OF FLUID	PRESSURE ( $\text{kg}_f/\text{cm}^2$ )	RECIRCULATION FLOWRATE ( $\text{m}^3/\text{hr}$ )
A	Distilled water	$0^+$	0.4, 0.5, 0.6
B	Distilled water	$0.2^+, 0.4^+, 0.6^+, 0.8^+$	0.4
C	Fermentation broth	$0^+$	0.4, 0.5, 0.6
D	[cell] = 1.7 g/l	$0.2^+, 0.4^+, 0.6^+, 0.8^+$	0.4
E	Fermentation broth	$0^+$	0.4, 0.5, 0.6
F	[cell] = 11.24 g/l	$0.2^+, 0.4^+, 0.6^+, 0.8^+$	0.4
G	Fermentation broth	$0^+$	0.4, 0.5, 0.6
H	[cell] = 45.42 g/l	$0.2^+, 0.4^+, 0.6^+, 0.8^+$	0.4
I	Fermentation broth	$0^+$	0.4, 0.5, 0.6
J	[cell] = 64.40 g/l	$0.2^+, 0.4^+, 0.6^+, 0.8^+$	0.4

#### 4.4.2 Study of Continuous Fermentation with Cell Recycling System By U.F.

The aim of this study is to find the optimum condition of the cell recycle system in an acetone-butanol fermentation. The parameters that were studied are glucose concentrations and dilution rates. Other parameters such as temperature, pH were fixed at the optimum point in a batch acetone-butanol fermentation process. The photograph and the schematic diagram of this operation are shown in

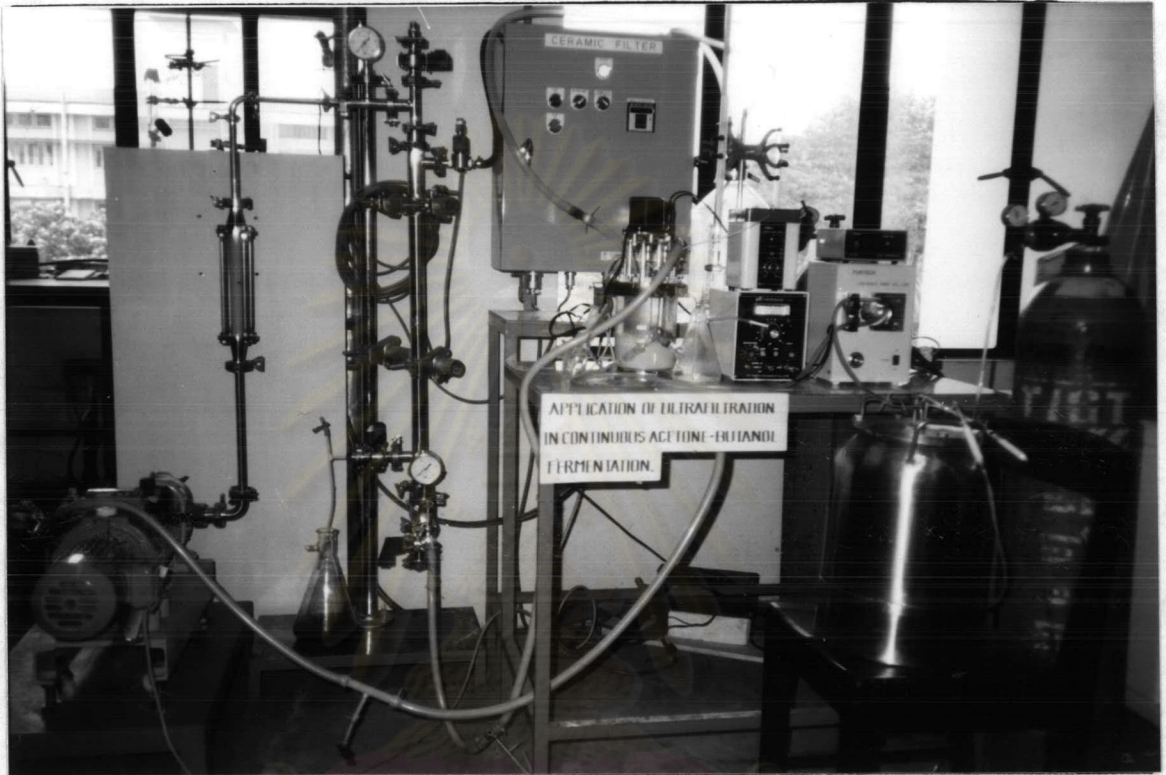

Figure 4.3 The cell recycle system

ศูนย์วิทยาศาสตร์  
จุฬาลงกรณ์มหาวิทยาลัย

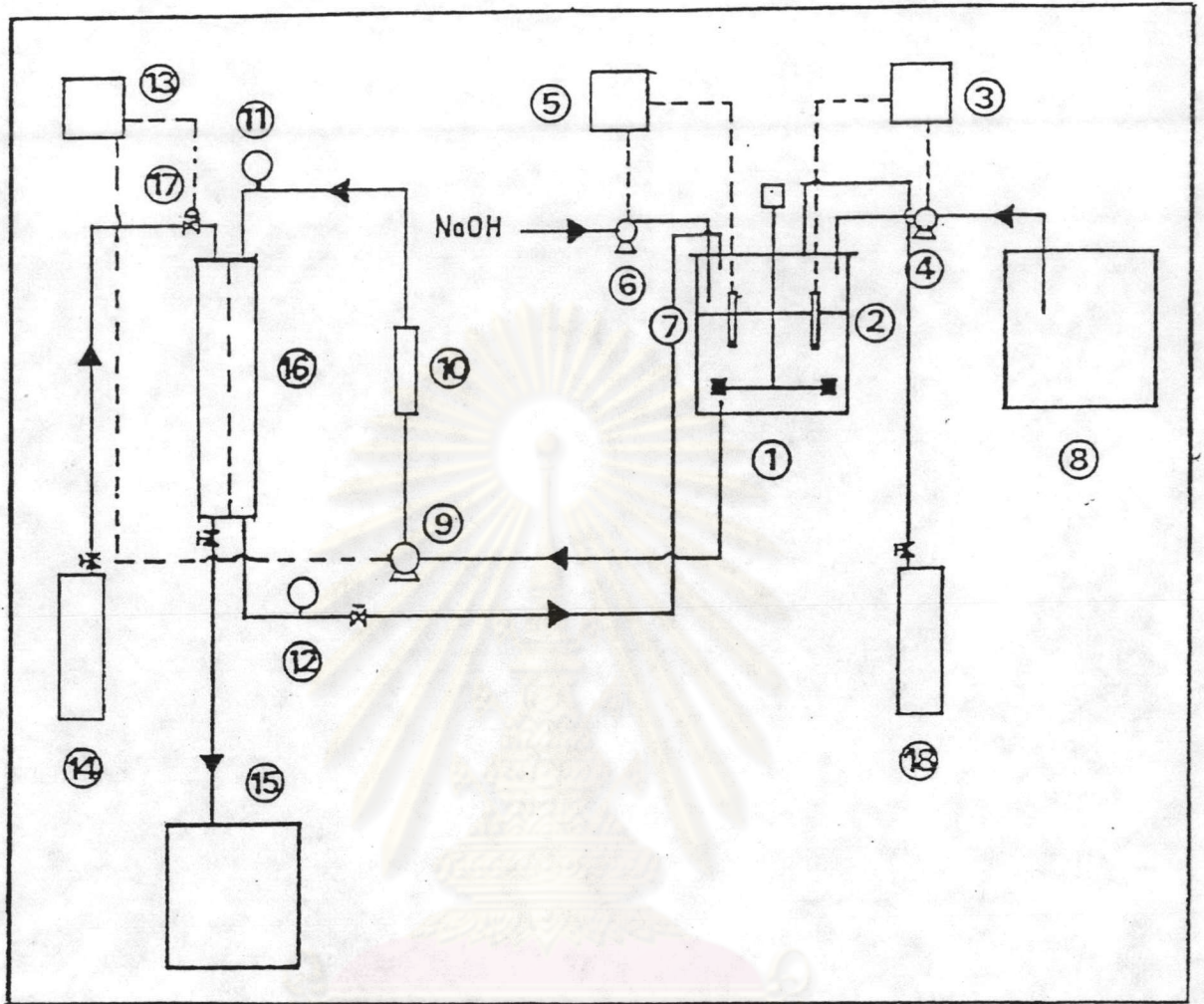

Figure 4.4 Schematic diagram of the cell recycling system

- |                       |                                 |
|-----------------------|---------------------------------|
| 1. fermentor          | 10. flow meter                  |
| 2. level sensor       | 11. inlet pressure gauge        |
| 3. level controller   | 12. outlet pressure gauge       |
| 4. feed pump          | 13. control block               |
| 5. pH controller      | 14. N <sub>2</sub> storage tank |
| 6. alkali feed pump   | 15. storage tank                |
| 7. pH controller      | 16. ultrafiltration membrane    |
| 8. feed tank          | 17. control valve               |
| 9. recirculation pump | 18. N <sub>2</sub> storage tank |



figures 4.3, 4.4 respectively. The procedure of this study was described as follows.

#### 4.4.2.1 Sterilization and Cleaning

The cell recycling system is cleaned by a water rinse and back flushed with demineralized water until the permeate flowrate is not less than the set point ( $11.5 \times 10^{-3} \text{ m}^3/\text{hr}$  at recirculation flow rate  $0.4 \text{ m}^3/\text{hr}$ , pressure  $0.0^+ \text{ kg}_f/\text{cm}^2$  at  $33.0^\circ\text{C}$ ). The system is steam sterilised by flushing with saturated steam at  $100^\circ\text{C}$ , for more than 30 min for each parts. The medium and other equipments are sterilised by keeping in the autoclave at 15 psi,  $121^\circ\text{C}$  for 15 min.

#### 4.4.2.2 Preparation of the Clostridium acetobutylicum

##### ATCC 824 culture

A 10 ml of Clostridium acetobutylicum ATCC 824 stored as liquid at  $0^\circ\text{C}$  in a glass tube is aseptically transferred to 100 ml of the sterilised medium in a 500 ml flask. The medium is kept anaerobic by bubbling pure nitrogen for 15 min, and is then kept at  $35^\circ\text{C}$  for an 18 hours growth. Culture tube and inoculum flask are shown in figure 4.5.

#### 4.4.2.3 Batch Operation in the Cell Recycling System

The 100 ml of the prepared culture (from 4.4.2.2) was aseptically transferred to 1-L of the sterilised medium in the 2-L fermentor. The agitation speed was maintained at about 200 rpm and the temperature was controlled at  $33\text{--}35^\circ\text{C}$ . The pH of the medium was controlled to be not less than 4.8 by automatic addition of 4N NaOH. The medium was kept anaerobic by bubbling of pure nitrogen.

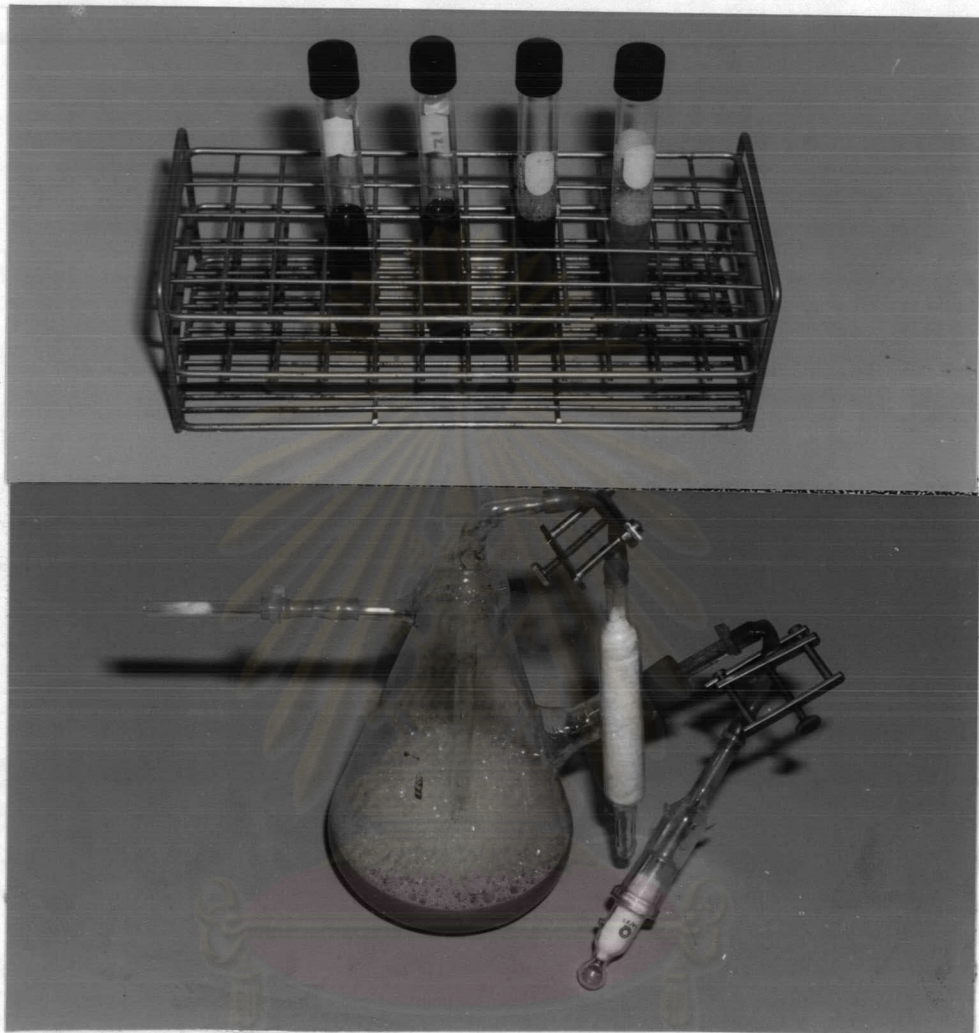

ศูนย์วิทยทรัพยากร  
จุฬาลงกรณ์มหาวิทยาลัย

Figure 4.5 The culture tube and the inoculum flask.

After the residue substrate concentration reached about 10 g/l (or the cell concentration was constant), 1.75-L of the sterilized medium was added and the circulation pump was turned on (9). The fermentation was performed in a batch mode (the fermentation broth was totally recycled) until the residue substrate concentration reached about 10 g/l (or the cell concentration was constant). Every 4 hours of the operation, 10 ml of broth was aseptically taken from the fermentor for determination of products, cell and glucose concentrations.

#### 4.4.2.4 Continuous Operation in the Cell Recycling System

The continuous operation was started after the residue substrate concentration reached about 10 g/l (or until the cell concentration was constant). After that, a sterilised medium was fed into the reactor by a peristaltic pump (4) controlled with a level controller (3), while the permeate was continuously discharged at a fixed flowrate (Q) to the product storage tank (15). The dilution rate ( $D = Q/V$ ) was defined by the continuous outflowrate of permeate (at 1-L of the total fermentation broth volume). The pH of the medium was controlled to be not less than 4.8 by automatic addition of 4N NaOH. The temperature was controlled at 33-35°C.

The dilution rate (D) was firstly controlled constant at  $0.11 \text{ hr}^{-1}$  until the residual substrate concentration reached about 5 g/l (or until the cell concentration was constant). Then the dilution rate (D) was changed to  $0.22 \text{ hr}^{-1}$ ,  $0.36 \text{ hr}^{-1}$ , and  $0.55 \text{ hr}^{-1}$  respectively.

In this study, run K (see table 4.2) was operated with a constant glucose concentration of 40 g/l, and the glucose concentrations for run L and M were 50 g/l, 60 g/l respectively. Run N was operated at 40 g/lit glucose concentration, and with a fixed dilution

rate of  $0.55 \text{ hr}^{-1}$  from the start of the continuous operation compared to productivity with run K. Run O was operated at 40 g/lit of glucose concentration with a fixed dilution rate of  $0.65 \text{ hr}^{-1}$  from the start of the continuous operation to check the solvent producing ability of the microorganism at a very high dilution rate. The data from experiments of run K-O were used for optimization of this cell recycle system. Every 4 hours of the operation, 5 ml of broth was aseptically taken from the fermentor for determination of cell concentration and 10 ml of permeate was taken for determination of products and glucose concentration. Table 4.2 was the operation parameters in run K-O.

Table 4.2 The Operation of cell recycle system for studying the effects of glucose concentration and dilution rate on solvent productivity.

RUN	FEEDING GLUCOSE CONCENTRATION (g/l)	DILUTION RATE ( $\text{hr}^{-1}$ )
K	40	started at 0.11 and increased to 0.22, 0.36, 0.55
L	50	started at 0.11 and increased to 0.22, 0.36, 0.55
M	60	started at 0.11 and increased to 0.22, 0.36, 0.55
N	40	Constant at 0.55
O	40	Constant at 0.65

#### 4.4.2.5 A batch operation for comparing with cell recycling system (run P)

The 100 ml of the prepared culture (from 4.4.2.2) was aseptically transferred to 2-L of the sterilised medium which contained glucose as much as the optimal feeding medium optimized from the experiments of the cell recycle system. The agitation speed was maintained at 200 rpm and the temperature was controlled at 35°C. The pH of the medium was controlled to not less than 4.8 by automatic addition of 4 N NaOH. The incubation time was 60-70 hours. The photograph and the schematic of this operation are shown in figures 4.6, 4.7 respectively.

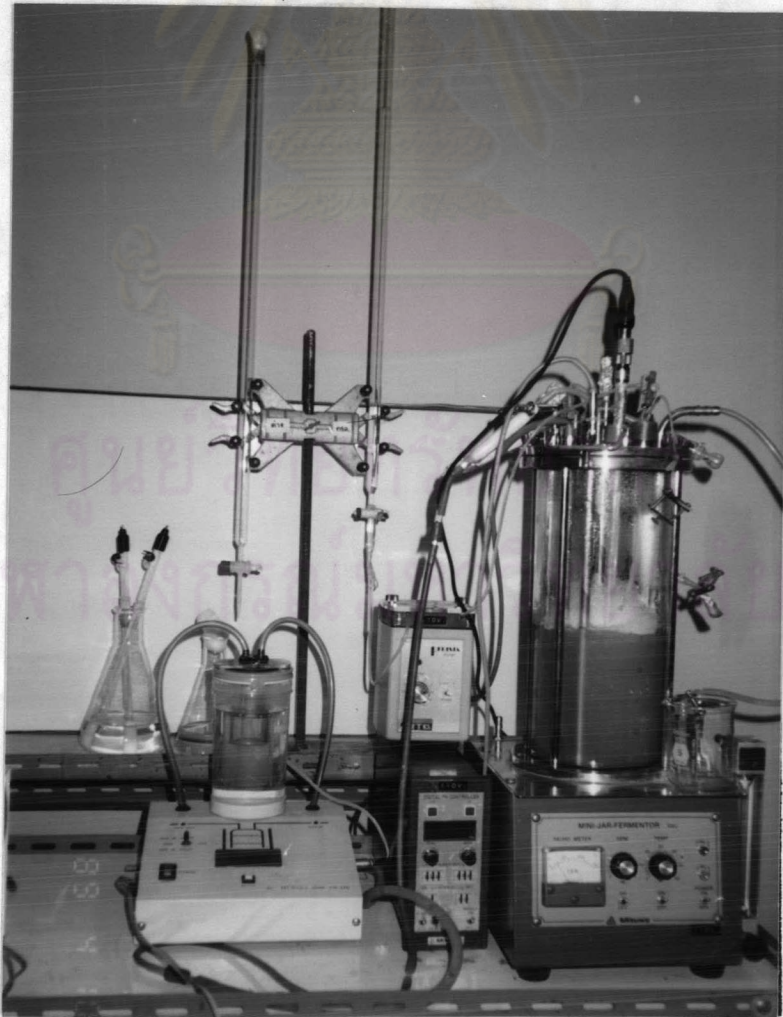

Figure 4.6 The batch fermentation

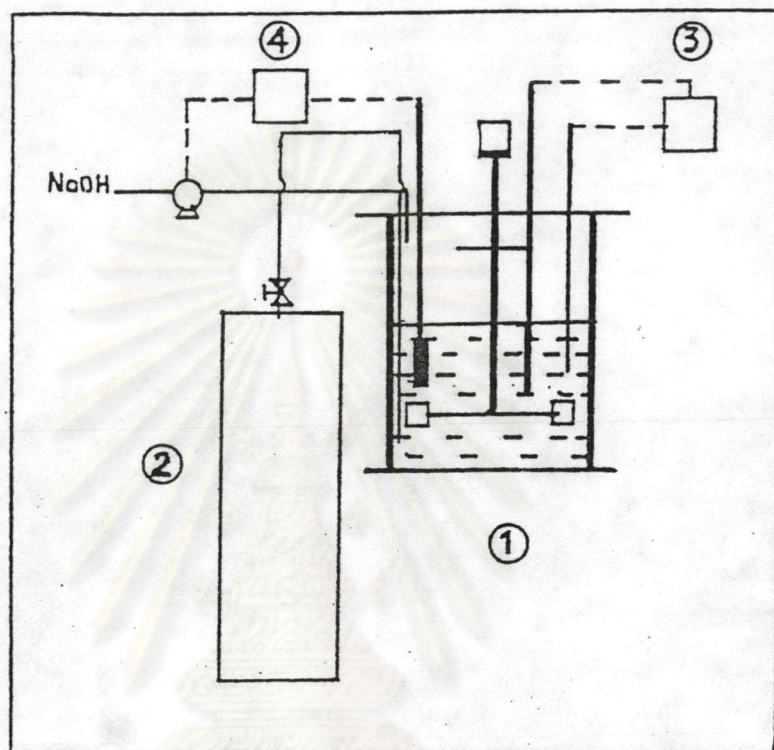

Figure 4.7 Schematic diagram of batch fermentation

1. fermentor
2. N<sub>2</sub> storage tank
3. Temperature sensor and controller
4. pH meter and controller

#### 4.4.3 Analysis

##### 4.4.3.1 Determination of Cell Concentration

Biomass concentration was determined by two independent methods:

1. Optical density measurement at 620 nm with a spectrophotometer: the samples were diluted in order to work in the linear range.

2. Dry weight : A 5 ml sample of the fermentation broth was centrifuged at 4,000 rpm for 10 min. The cell pellet was resuspended and washed twice with distilled water and then dried for 48 h, at 90 °C and weighed.

##### 4.4.3.2 Determination of Product Concentrations

Acetone, n-butanol, ethanol, acetic acid and butyric acid were determined by gas chromatography using a Shimadzu Model G<sub>c</sub> 7 A<sub>G</sub> equipped with a flame ionization detector. Separation took place in a 2m x 0.125 in stainless steel column (packed with Porapak Q 80-100 mesh) at 210 °C, and N<sub>2</sub> was used as carrier gas. The injector temperature was 280 °C, and the detector temperature was 300 °C. The analysis of the chromatographic data was with a Chromatopac CR1A recorder integrator. Flow rate of carrier gas was 50 ml/min, retention time of butanol, acetone, ethanol, acetic acid and butyric acid are 4.09, 1.77, 1.31, 3.10 and 9.96 min respectively.

##### 4.4.3.3 Determination of Glucose Concentration

Glucose was determined by a YSI Model 27 glucose analyzer.