

Chapter 3

IBM 3270 Coaxial Type A Protocol Overview

The RG62AU coaxial cable is used to connect between control unit and device (terminal, printer, PC) with a maximum length of 1.5 kilometers. The data transmission is encoded by using the bi-phase Manchester II technique which has a fix bit rate of 2.3587 MHz.

In the bi-phase Manchester II encoding, the 1st half of the bit cell consists of the complementary data and the 2nd half of the bit cell is the true data. There is always a central bit transition in the normal bit cell except in the transmission starting or ending sequence which have the code violations in the bit frame.

The transmission packet between the device and control unit is composed of the following:

1. Transmission Start Sequence (Code Violation Sequence).
2. One or more data frames.
3. Transmission Ending Sequence (Mini Code Violation Sequence).

At the beginning of the packet, five consecutive "1" bits followed by one and a half bits high level and



one and a half bits low level will be transmitted by device or the control unit. This is called the transmission Start Sequence. At the end of the packet, a Transmission Ending Sequence is sent to signify the completion of the data frame. It consists of a "0" bit followed by two bits of high level without central bit transition. Figure 3.1 illustrates the Start and Ending Sequence.

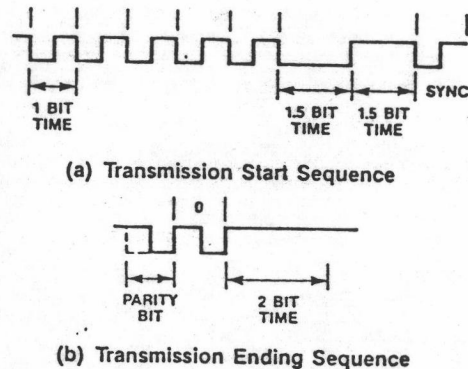

Figure 3.1 Transmission Start and Ending Sequence

The data frame is composed of 12 bits starting with "1" sync bit and ending with even frame parity bit. The frames have three formats: command word, data word and status word.

3.1 Command Word

The command word is from control unit only. It can be read or write type. For the read type command, the device responds with either data or status word. For a write type command, the device responds with TT/AR

(Transmit Turnaround/Auto Response).

- b1: Sync Bit = 1.
- b2-4: Address Bits. Bits 2-4 = 0 for Base. Bits 2-4 = X for Feature.
- b5-9: Command ID.
- b10: Unused.
- b11: Command Bit = 1.
- b12: Frame Parity. Even parity for b1 through b11.

3.2 Data Word

The data word can be from control unit or device. For control unit, it always follows the write command. For device, it is the response of the read command.

- b1: Sync Bit = 1.
- b2-9: Data Byte. Bit 2 is the most significant bit and bit 9 is the least significant bit.
- b10: Data byte parity. Odd parity for bit 2 through 9.
- b11: Data Bit = 0.
- b12: Frame parity. Even parity for b1 through b11.

3.3 Status Word

The status word is returned from the device in response to the Poll command from the control unit.

b1: Sync bit = 1.

b12: Frame even parity.

For no keystroke returned:

TT/AR: b2-11 = 0.

Poll request: b6 = 1.

Operation complete: b9 = 1.

POR complete: b8 = 1, b10 = 1.

Feature error: b11 = 1.

For keystroke returned:

b2-9: Keyboard scan code.

b10: 1.

b11: 0.

3.4 Features and Commands used by control unit and device

3.4.1 Poll

This command doesn't use the address portion of the command word. The functions of the frame bit 2 and bit 3 are assigned as follows:

b2	b3	IBM 3278	IBM 3287 Printer.
1	1	Enable keyboard Clicker.	Enable Operation.
0	1	Disable Keyboard Clicker.	Disable Operation.
1	0	Sound Alarm.	Sound Alarm.
0	0	None of the above.	None of the above.

The following status frames are returned to the control unit in response to the Poll command:

Response	b2	b3	b4	b5	b6	b7	b8	b9	b10	b11
POR Complete	0	0	0	0	0	0	1	0	1	0
TT/AR	0	0	0	0	0	0	0	0	0	0
Keystroke Available	2-9 Scan Code							1	0	
Base Status	0	0	0	0	x	0	0	x	0	x

The base status bit 6 is set for poll request (for DFT and IBM 3287 only). Bit 9 is active if the operation is complete. The feature error will set bit 11. The priority of the multiple poll responses is listed as below.

1. Feature error.
2. POR complete.
3. Poll request.
4. Operation complete.
5. Keystroke available
6. Any other feature status.

3.4.2 Reset

This command sets the buffer address counter to "0050H" for display station, and "0000H" for printer. TT/AR is returned to the control unit.

3.4.3 Read Data

The return of this command is the data at the location of current buffer address counter. The address counter is incremented by one at the completion

of the command.

3.4.4 Load Address Counter High

The decoding of this command loads the next data frame into the high byte of the buffer address counter.

3.4.5 Read Address Counter High

The content of the high byte buffer address counter is sent in response to this command.

3.4.6 Clear

This command clears all or part of the data buffer to null (00). The clear operation terminates at the location where the data value matches with the pattern byte (The data frame that follows the command) in conjunction with the Mask Register, or terminates at address 0 if no match has been found. All the locations from the starting address up to the matched location (Not included) are cleared. The address counter contains the matching location address. The corresponding locations of the EAB are also cleared to nulls under the control of the Mask Register.

3.4.7 Read Terminal ID

The response of this command is the return of the following data byte:

b2-5: Keyboard ID.

b6-8: Terminal ID.

b9: 0.

3.4.8 Load Control Register

This command loads the next data frame into the Visual/Sound Register. The function of each bit is listed as follows:

Frame Bits	Function
2	80 characters per line if this bit is "0", 132 characters if "1".
5	Inhibit feature step of the buffer address counter.
6	Inhibit display.
7	Inhibit cursor display.
8	Reverse image cursor.
9	Cursor Blinking.

3.4.9 Read Multiple

The Read Multiple causes the device to return one or more data words from buffer memory beginning at the current buffer address counter. The counter increments by one each time the buffer is accessed. The maximum number read depends on the Secondary Control Register bit 0. If this bit is "0", the read will terminate when the two low order bits of the buffer address counter becomes "00" which gives a maximum

of 4 bytes of reading data. If it is "1", the read will terminate when the five low order bits of the counter becomes "00000" and give a maximum of 32 bytes of data.

3.4.10 Write Data

The decoding of the Write Data command causes the device to put all the following data frames into the buffer memory until another command is received. The buffer address counter increments by one for every data written.

3.4.11 Read Status

Status is returned to control unit, in response to this command, the status details are as follows:

b1: Sync bit.
b2-3: 0.
b4 "1" for not busy.
b5-6: 0.
b7: "1" for feature error.
b8: "1" for operation complete.
b9-11: 0.
b12: Frame parity.

3.4.12 Insert

This command causes the device to accept the following data frame and put it in the buffer storage at the current address counter location. The old storage

data is shifted one location ahead. This process continues for each successive location until a null (00) character or attribute is found, or the address counter steps to zero.

The EAB (Extended attribute buffer) is also shifted with the contents of the EAB MASK register being inserted at the initial location.

3.4.13 Search Forward

This command causes the device to search for each buffer storage starting with the current address counter. This process will keep on going until a match in the pattern byte (The data frame that follows the command). The bit comparison occurs only on the bit with corresponding mask bit equal to "1". The address counter is incremented by one after each comparison. The address counter contains the value of the buffer address of the first matched data. The search will terminate at address 0 if no match is found.

3.4.14 Poll Acknowledge

This command is sent by the control unit when it receives the non-zero status. TT/AR is returned by the device after receiving this command. If the device receives a second Poll command instead of Poll Acknowledge, it will return same status. In the case that a new status is available before the first returned

status is acknowledged, the new status will be stacked by the device.

3.4.15 Search Backward

The operation of Search Backward command is similar to Search Forward command except that the address counter is decremented by one after each comparison. If no byte match is found the search will terminate at one location past address 0. (Address counter bits 0 to 11 are set to "1").

3.4.16 Load Address Low

Similar to Load Address High command, this command causes the device to load the next data frame into the low byte of the buffer address counter.

3.4.17 Read Address Low

Similar to Read Address High command, the content of buffer address low counter is returned in response to this command.

3.4.18 Load Mask

This command causes the device to load the next byte into the mask register. The mask register is used with Search and Clear commands. A "1" bit in the mask enables the bit in the buffer to compare with the pattern byte.

3.4.19 Load Secondary Control Register

The decoding of this command interprets the data byte following the command as the control bit for the Read Multiple command. If b0 is "0", the termination of Read Multiple command will be 0 to 4 bytes. If it is "1", the termination will be 0 to 32 bytes.