



CHAPTER II

LITERATURE REVIEW

2.1 Basic Principles of Plasma

Plasma is an ionized gas, and is usually considered to be a distinct phase of matter as depicted in Figure 2.1. “Ionized” means that at least one electron has been removed from a significant fraction of the molecules. The free charges make the plasma electrically conductive so that it couples strongly to electromagnetic fields. This fourth state of matter was first identified by Sir William Crookes in 1879 and dubbed "plasma" by Irving Langmuir in 1928 (<http://www.en.wikipedia.org>).

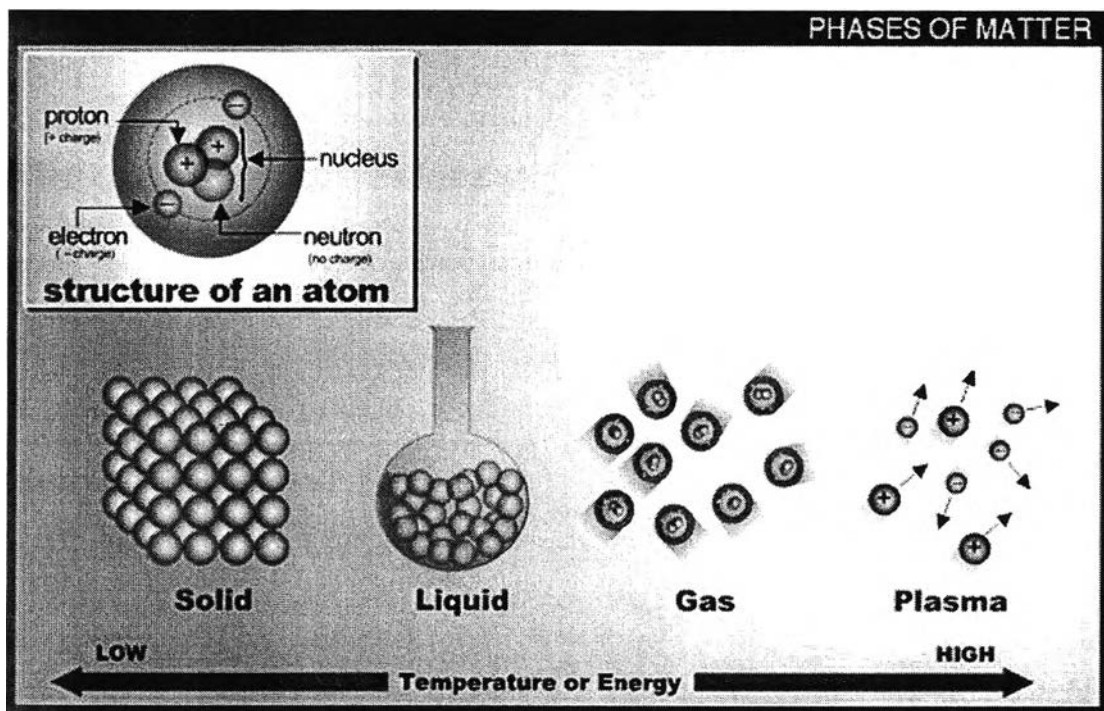

Figure 2.1 Phase of matter consists of solid, liquid, gas, and the fourth state named “plasma”.

Gaseous plasma consists of negatively and positively charged particles in an otherwise neutral gas. The positively charged particles are mostly cations, but the negatively charged particles can be either electrons or anions. The neutral species may be the mixture of free radical species with stable neutral

gases. Plasma possesses two important properties (Eliasson and Kogieschatz, 1991).

1) *Quasi-neutral property*

The total density of negative charge carriers must be equal to the total density of positive charge carriers due to low degree of ionization.

2) *Interaction with electromagnetic fields*

Plasma can have some interactions upon applying an electromagnetic field due to the fact that they consist of charged particles.

Normally, plasma can occur in all states (Nasser, 1971). Plasma in solid is called solid-state plasma while plasma generated in the liquid and gaseous states does not have any specific names. Only gaseous plasma is shortly called as “plasma”. There are many differences between plasmas and gases. Their differences include pressure, distributions of charged-particle density in the entire plasma volume, and temperature.

2.1.1 Generation of Plasma

There are several means of generating charged particles to produce plasmas, e.g. collisions between cosmic rays and gases in atmospheric layers. However, in the present study, an externally intense electric field is applied across metal electrodes to cause the reduction in its “potential barrier” and thus the energy that each electron requires for leaving the metal surface. The most interesting phenomenon on the metal surface under an extremely high electric field is that many electrons can leak from the surface despite its less kinetic energy to overcome the potential barriers. This phenomenon is known as “tunnel effect”. And then, the plasma is first generated by the collisions between the electrons emitted from the surface of metal electrodes and the neutral molecules. This process of plasma generation is normally known as the “field” emission process.

The electrons liberated from the metal surface will immediately be accelerated to move corresponding to the direction of the electric field, and then can collide with any neutral gaseous particles in their vicinity to form the ionized gases with an additional set of electrons. Accordingly, these electrons can further move and collide with other species. As a result, a large quantity of electrons, including the

excited atoms and molecules, ions, and radicals, can be formed in the bulk of the gases within a very short period of time after the application of electric field has been started. Many active species can initiate the chemical reactions, leading to the production and destruction of the chemical species (Kruapong, 2000). Table 2.1 shows some important collision mechanisms.

The combined steps of the field emission process among these plasma species and the collisions between the species and the electrode surfaces are referred to as “electric discharges” phenomena.

Table 2.1 Collision mechanisms in the plasma (Nasser, 1971)

Collision	Reaction
Elastic Collision	$e^- + A \longrightarrow e^- + A$
Excitation	$e^- + A \longrightarrow e^- + A^*$
Ionization	$e^- + A \longrightarrow 2e^- + A^+$
Attachment	$e^- + A \longrightarrow A^-$
Dissociative Attachment	$e^- + B_2 \longrightarrow B^- + B$
Recombination	$e^- + B_2^+ \longrightarrow B_2$
Detachment	$e^- + B_2^- \longrightarrow 2e^- + B_2$
Ion Recombination	$A^- + B^+ \longrightarrow AB$
Charge Transfer	$A^\pm + B \longrightarrow A + B^\pm$
Electronic Decomposition	$e^- + AB \longrightarrow e^- + A + B$
Atomic Decomposition	$A^* + B_2 \longrightarrow AB + B$

Plasma is divided into two types. The first type is “thermal plasma” or “equilibrium plasma”. In this type, the temperature between gas and electron is approximately equal, which is close to thermodynamic thermal state (Harndumrongsak, 2002). An essential condition for the formation of this plasma is sufficiently high working pressure. An example of this plasma is arc discharge.

The second type is “non-thermal plasma” or “non-equilibrium plasma”, which is characterized by low gas temperature and high electron temperature. Those typical energetic electrons may have energy ranged from 1 to 10

eV, which corresponds to the temperature of about 10,000 to 100,000 K (Rosacha *et al.*, 1993). This plasma can be classified into several types depending upon their generation mechanism, their pressure range, and the electrode geometry (Eliasson *et al.*, 1987). Examples of this plasma are radio frequency discharge, microwave discharge, glow discharge, corona discharge, and dielectric-barrier discharge, where the latter will be used in this study.

2.1.1.1 Thermal Plasma

Thermal plasma or “hot plasma” is close to thermodynamic equilibrium. It has a uniform temperature for all particles and a very high temperature in the discharge region. An essential condition for the formation of thermal plasma is a sufficiently high working pressure. The large number of collision between particles leads to rapid redistribution of energy so that equilibrium is reached. An example of this plasma is arc discharge.

Thermal plasma technology offers a wide range of advantages over other waste management solutions due to the very high temperatures it generates, changing the state of wastes to destroy hazardous materials. It is also highly flexible and easy to control, with a low environmental impact of its own. In addition, it enables the production of a valuable vitrified slag that may be used in construction and other applications.

With thermal plasma treatment forming the core of the process, the team is also seeking to develop and implement innovative pre- and post-treatment processes to minimize the extent of any secondary effluent streams.

2.1.1.2 Non-Thermal Plasma

Non-thermal plasma or “cold plasma”, in contrast, is far from thermodynamic equilibrium. Typically, electrons in this plasma have very much higher temperature than the heavy ions and neutral species particles. Its uses are based chiefly on the reactivity of ions or radicals generated in the plasma for gas phase or surface reaction (Kroschwitz *et al.*, 1998). This group includes radio frequency, microwave, glow, dielectric-barrier, and corona discharges.

2.1.1.2a Generation of Non-thermal Plasmas

It is customary to divide non-thermal plasmas into distinctive groups depending on the mechanism used for their generation, their

pressure range, or the electrode geometry. The most notable characteristics of five non-thermal discharges are listed as follows (Eliasson and Kogieschatz, 1991), where the latter two are explained in detail due to its much more importance for chemical synthesis and conversion.

- 1) Glow discharge
- 2) Microwave discharge
- 3) Radio frequency discharge
- 4) Dielectric barrier discharge
- 5) Corona discharge

In Figure 2.2, the discharges are grouped according to their temporal behavior, pressure range, and appearance.

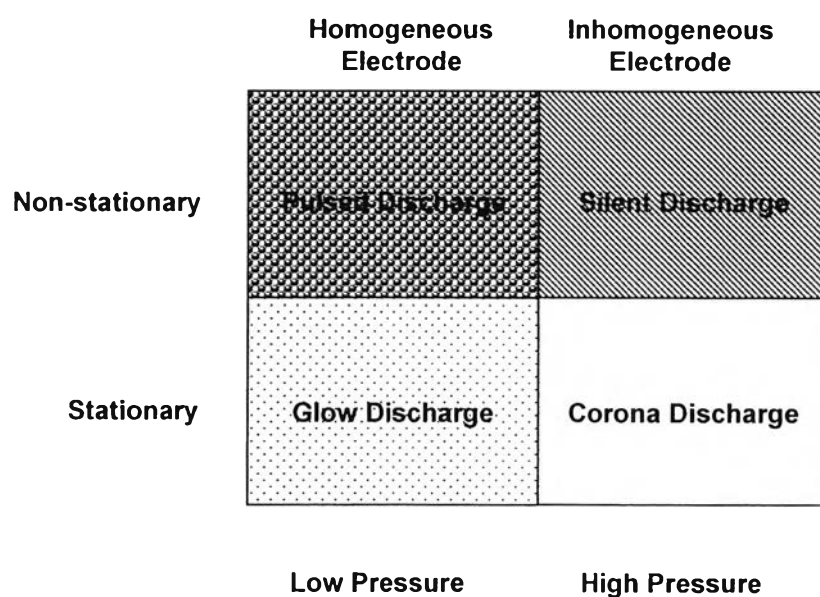

Figure 2.2 The various types of discharge classified according to temporal behavior, pressure, and geometric electrode (Eliasson and Kogieschatz, 1991).

General Features of Dielectric Barrier Discharge:

Dielectric barrier discharges (DBD) comprise a specific class of high-voltage, AC, and gaseous discharges that typically operate in the near-atmospheric pressure range. It has been shown that the corona-to-spark transition at high levels of voltage is prevented in pulsed corona discharges by employing special nanosecond pulse

power supplies. An alternate approach to avoid formation of sparks and current growth in the channels formed by streamers is to place a dielectric barrier in the discharge gap. This is the principle idea of DBD. Sometimes dielectric barrier discharges are also called silent discharges because of the absence of sparks that are accompanied by local overheating, generation of local shock waves, and noise.

An important advantage of the dielectric barrier discharge is the simplicity of its operation. It can be employed in strongly non-equilibrium conditions at atmospheric pressure and at reasonably high power levels, without using sophisticated pulse power supplies. These discharges are industrially applied as well in CO₂ lasers, and as a UV-source in excimer lamps. DBD application for pollution control and surface treatment is quite promising, but the largest expected DBD applications are related to plasma panels for large-area flat television screens.

Important steps in understanding the physical nature of the DBD were made by Bussin (1932) and Klemenc *et al.* (1937). Their work showed that this discharge occurs in a number of individual tiny breakdown channels, which are now referred to as microdischarges and are intensively investigated for their relationship with streamers.

General Configuration and Parameters of Dielectric Barrier Discharges:

The defining feature of DBD is the presence of dielectric layers that make it impossible for charges generated in the gas to reach the conducting electrode surfaces. With each half-cycle of the driving oscillation, the voltage applied across the gas exceeds that required for breakdown, and the formation of narrow discharge filaments initiates the conduction of electrons toward the more positive electrode. As charge accumulates on the dielectric layer at the end of filament, the voltage drop across the filament is reduced until it falls below the discharge-sustaining level, whereupon the discharge is extinguished. The low charge mobility on the dielectric not only contributes to this self-arresting of filaments but also limits the lateral region, over which the gap voltage is diminished, thereby allowing parallel filaments to form in close proximity to one another. Thus, the entire gas-filled space between parallel electrodes can become, on average, uniformly covered by transient discharge filaments, each roughly 0.1 mm in diameter and lasting only about 10 ns.

The dielectric barrier discharge gap usually includes one or more dielectric layers located in the current path between metal electrodes. Two specific DBD configurations, planar and cylindrical, are illustrated in Figure 2.3. Typical clearance in the discharge gap varies from 0.1 mm to several centimeters. Breakdown voltages of these gaps with dielectric barriers are practically the same as those between metal electrodes. If the dielectric barrier discharge gap is a few millimeters, the required AC driving voltage with frequency of 500 Hz to 500 kHz is typically about 10 kV at atmospheric pressure.

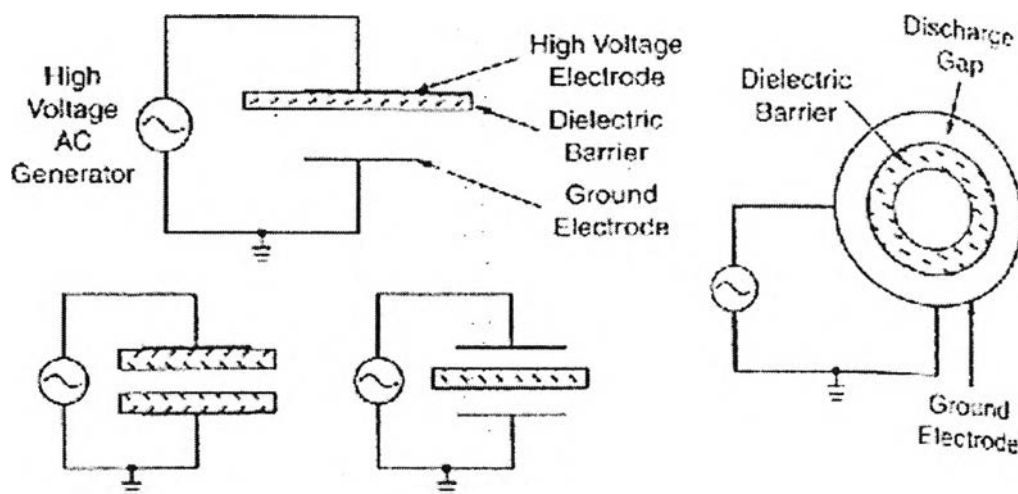

Figure 2.3 Common dielectric barrier discharge configurations.

The dielectric barrier can be made from glass, quartz, ceramics, or other materials of low dielectric loss and high breakdown strength. Then, a metal electrode coating can be applied to the dielectric barrier. The barrier-electrode combination also can be arranged in the opposite manner, e.g. metal electrodes can be coated by a dielectric. As an example, steel tubes coated by an enamel layer can be effectively used in the dielectric barrier discharge.

The dielectric is the key for the proper functioning of the discharge. Once ionization occurs at a location in the discharge gap, the transported charge accumulates on the dielectric. The dielectric serves two functions: (1) it limits the amount of charge transported by a single microdischarge and (2) it distributes the microdischarges over the entire electrode area.

The DBD unique combination of non-equilibrium and quasi-continuous behavior has provided the basis for a broad range of applications and fundamental studies. Its use in industrial ozone reactors has generated interest in optimizing conditions for specific chemical reactions. To this end, experimental DBD studies have explored different gas mixtures, electrical characteristics, and geometries. Related work has focused on maximizing the ultraviolet radiation from excimer molecules produced in DBD. Several groups have modeled single-filament dynamics in order to account for many two- and three-body reactions involving electrons, ions, neutral atoms, and photons. These efforts have been moderately successful in explaining and predicting the chemical and radioactive properties of various DBD systems. On another research front, it has been seen that the transverse spatial distribution of discharge filaments in 2D parallel-plate DBD can take the form of stable and large-scale patterns reminiscent of those associated with magnetic domains or Rayleigh-Bénard convection. These patterns have been modeled with some success using methods that apply generally to pattern formation in nonlinear dynamical systems. Thus, the dynamic interactions between filaments, as well as the chemical and electronic interactions within filaments, have proven interesting. The schematic for dielectric barrier discharge reactor is shown in Figure 2.4.

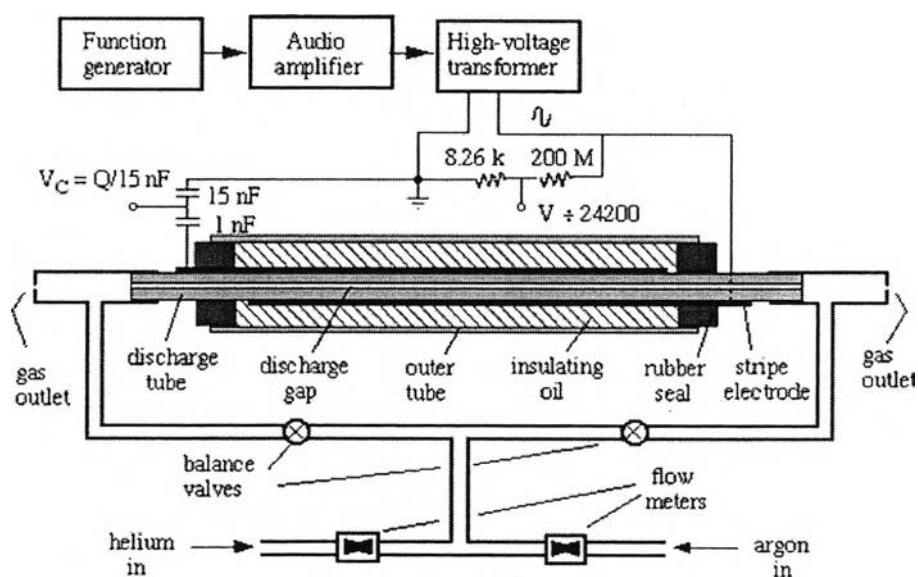

Figure 2.4 Schematic for dielectric barrier discharge reactor.

Corona Discharge: One type of discharge, which can operate at both extremely low and high pressure. This type of discharge is generally constructed with inhomogeneous electrode geometries; e.g. a pointed electrode and a plane electrode (or pin and plate), as shown in Figure 2.5. The discharge generated by this kind of electrode is called corona discharge.

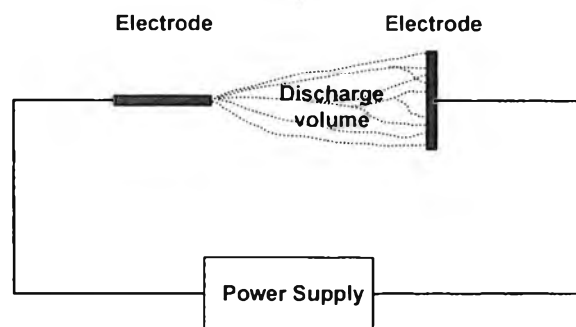

Figure 2.5 The corona discharge generated by inhomogeneous electrodes.

Types of Corona Discharge:

Corona discharges exist in several forms, depending on the polarity of the field and the electrode geometrical configurations.

a) Positive Corona

For positive corona in the pin-plate electrode configuration, there is a corona inception voltage, which depends on the radius of the point and the gap spacing. Discharges start with burst pulse corona, and when the voltage is increased, streamers are produced, leading to the typical corona phenomenon named streamer corona followed by glow corona. By increasing the voltage further, breakdown occurs, and a spark bridges the gap, as depicted in Figure 2.6. Unlike Hermstein's positive sheath (Hermstein, 1960) or Hermstein's glow, the positive streamer corona is a discharge confined to a narrow channel, which originates at the electrode. It produces an unsteady current (because the streamer is repetitive), is quite noisy, and is the direct precursor to a spark.

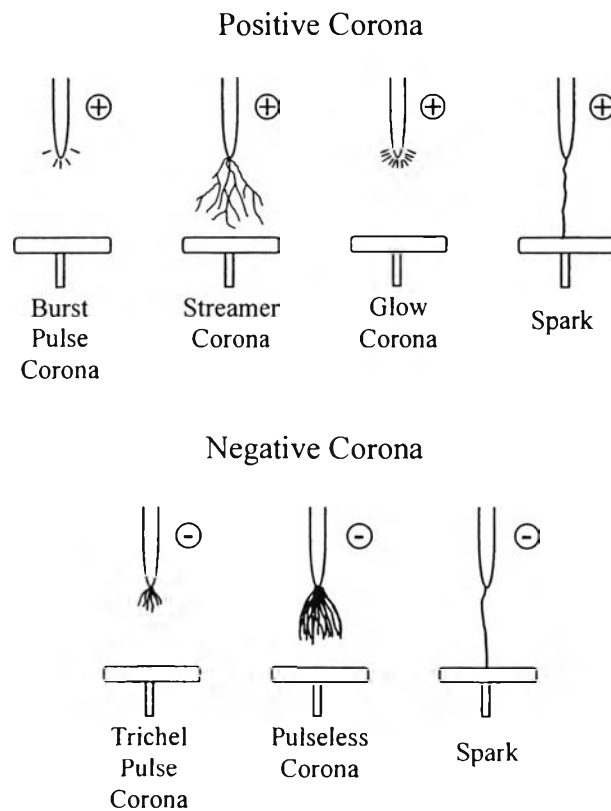

Figure 2.6 Schematic of various forms of corona discharge depending upon applied voltage at constant electrode geometrical configuration (Chang, 1991).

Positive corona depends more on photoionization for its propagation. The positive streamer, for example, may advance at as much as one percent of the speed of light. In either case, the ultraviolet photon flux from ion-electron recombination is quite large (Chang, 1991).

b) Negative Corona

For negative corona in the same geometry, once voltage is increased, the so-called Trichel pulses are generated. Short current pulse or pulseless corona is observed with a frequency proportional to the applied voltage, and also depends on the radius of the point. As the voltage is increased further, a glow develops before complete breakdown occurs.

Negative corona generally propagates by impact ionization of the gas molecules, which is in slightly different manner from positive corona. Due to space-charge phenomena in the neighborhood of the point, the negative corona is less sensitive to the radius of curvature of the point than the positive corona. It is the small

radius of curvature of the point that leads to the high fields necessary for ionizing the neutral molecules. The field drops rapidly as one move away from the point toward the other electrode. It is very important that the applied voltage is not too high; otherwise the corona might bridge the gap, produce a spark, and finally break down. In this sense, the corona discharge can be considered a partial breakdown.

The characteristic of corona discharge is that the generated-plasma volume excited is nearly smaller than the total discharge volume. This tends to be not suitable for large quantities of chemical species production. There are, however, applications where only very small concentrations of excited or charged species are needed. The outstanding example is electrostatic precipitators, which are operated at industrial scales for collecting the particulate emissions in the utility, steel, paper manufacturing, and cement and ore-processing industries.

2.1.1.2b *Initiation of Chemical Reactions in Non-Thermal Plasma*

For initiation of chemical reactions in non-thermal plasma, the energy is very often transferred solely by the electrons. Firstly, the accelerated electrons are created by discharge mechanism. Secondly, such electrons collide with neutral gas and excite them to higher energy state. Finally, the excited gas molecules can either dissociate or initiate to the new chemical species because of their high energy level. The same can also be applied to ions. For example, the reaction schematic is demonstrated below (McQuarrie *et al.*, 1987).

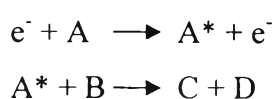

where A, B are reactant.

C, D are product.

A* is the excited reactant marked by an asterisk (*).

Normally, this reaction $A + B \longrightarrow C + D$ may only take place at high temperatures, but in this case, the product C and D can take place at a lower temperature induced by non-thermal plasma.

Besides transferring energy to gas molecules via fast electrons and ions, photon can also involve with initiating the new chemical species if it is energetic enough. The photon is taken place by emitting energy of excited molecules to lower state. The characteristics of electron and photon are quite different.

2.2 Applications of Non-Thermal Plasma in Chemical Synthesis

The non-thermal plasma has been widely used in many industrial applications. The first use of chemical synthesis via silent discharge is ozone generation by Siemen (Horvath, 1980). Under selective experimental conditions, organic plasma chemistry can be a valuable synthetic method. Main areas of applications are the generation of reactive species, isomerizations, eliminations, cyclizations, condensations, and multistep reactions (Suhr, 1983).

For the industrial production of epoxides, ethylene oxide, which is the most important epoxide in industrial processes, is made by conventional methods using catalysts. There are also some studies on plasma organic syntheses, such as oxidations of aromatic, liquid hydrocarbons, and olefins using oxygen plasma (Patiño *et al.*, 1995; Suhr *et al.*, 1984; Suhr *et al.*, 1988; Tezuka and Yajima, 1995). Furthermore, the selectivity of product formation is far superior to plasma oxidations in the gas phase, making these techniques attractive for preparative chemistry (Suhr *et al.*, 1984).

The previous studies on plasma oxidation at low pressure suggested that the most important species in the plasma partial oxidation was $O(^3P)$ (Patiño *et al.*, 1996; Patiño *et al.*, 1995; Suhr *et al.*, 1988; Suhr, 1983; Patiño *et al.*, 1999; and Suga and Sekiguchi, 2005). The following reaction was proposed for the epoxidation of the carbon double bond:

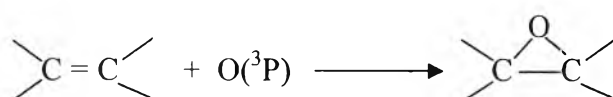

In addition, Jeong *et al.* (2000) reported that the concentration of $O(^3P)$ decreased significantly with increasing the distance between the tip and the tube in discharge reactor, which is in good accordance with Suga and Sekiguchi's experiments.

In recent work, there have been the extensive attempts to oxidize carbon double bond into epoxide by exposing a liquid 1-decene to atmospheric pressure glow plasma (APGP), where oxygen diluted with argon was used as a plasma gas. The results showed that the yields of all products (1,2-epoxydecane, 1-decanal, 1-

nonanal, and 2-decanone) increased linearly with increasing reaction time and shortening distance between the tip of the tube and the liquid surface, and the epoxide could be obtained with the highest yield (Suga and Sekiguchi, 2005).

2.3 Catalytic Plasma Processing

The plasma properties can be influenced by catalysts in plasma zone. The catalysts can also change the reaction products due to the conductive surfaces, which lead to surface reaction. While the catalyst properties can also be influenced by plasma because it provides the heating of catalysts, resulting in desorbing of surface species (Kraus, 2001). The synergism between catalysts and plasma is achieved if this combination can improve reactant conversion or higher selectivity to the desired products as compared to the sole plasma or catalyst technique.

The combination of catalysis and non-thermal plasma tends to offer a number of advantages over the conventional catalytic processes. One of them is low operational temperature close to room temperature at near or slightly higher than atmospheric pressure as described above. This implies comparatively lower energy consumption used for activating catalysts. Moreover, the catalytic problems at high temperature operation, i.e. catalyst deactivation, catalyst regeneration, and catalyst replacement, could be eliminated. However, they often provide less selectivity for a desired product than the catalysis technique (Pietruszka *et al.*, 2004).

The gas temperature is the most important factor indicating the occurrence of the catalytic reaction. Moreover, at low temperature where the catalysts were not active, the plasma influence was observed. At the higher temperature, the catalysts became active. Thus, the catalytic plasma effect was still observed (Liu *et al.*, 1997; and Pietruszka *et al.*, 2004). As reported by Heintze *et al.* (2004), they investigated the combined DBD and Ni/ α -Al₂O₃ in the partial oxidation of methane. The results were reported that at lower temperatures, this combined catalyst-plasma had no influence on the conversion and product selectivity. At these temperatures, the plasma showed the dominant role. At the higher temperatures, however, the catalyst promoted the oxidation of CO to CO₂.

Malik and Malik (1999) investigated combined system of cold plasma and a catalyst for VOC decomposition. They found that the addition of a suitable catalyst, particularly supported noble metal catalysts, such as platinum, palladium, rhodium and ruthenium, could activate CH_4 at relatively low temperatures with faster rates and could further improve the efficiency, as well as the selectivity for the desired products. Noble metal electrodes showed the best results for the conversion of CH_4 to C_2 hydrocarbons in a pulsed corona discharge with the following order: platinum > palladium > copper.

Suttiruangwong (1999) studied the conversion of methane for partial oxidation of methane (POM) in a packed-bed reactor under AC corona discharge without and with Cu/ZnO catalyst. For reaction without catalyst, it was found that the non-catalytic system gave much higher CH_4 conversion than the catalytic system, and products mainly consisted of C_2 hydrocarbons. Methane conversion and product selectivity increased with decreasing total flow rate and increasing applied voltage. For reaction with catalyst, it gave the feasibility of methane conversion at atmospheric conditions, but the amount of methanol produced was still low. Synthesis gas was also found in the product stream.

Viriyasiripongkul (2000) investigated the oxidative coupling of methane to produce higher hydrocarbons by using AC electric discharge without and with zeolite catalyst at ambient condition. For system with catalyst, the presence of Pt/KL zeolite enhanced the oxygen conversion and the selectivity for ethylene. Moreover, hydrogen and carbon monoxide were the main products. For system without catalyst, it was found that methane, oxygen, and ethane conversions, as well as yields of C_2 hydrocarbons (ethylene and acetylene), increased with increasing applied voltage and decreasing either frequency or total flow rate.

Saktrakool (2003) developed a combined plasma and photocatalytic system for oxidation of ethylene as a model of VOC removal. Higher applied voltage and stage number of plasma reactors enhanced C_2H_4 conversion and CO_2 selectivity, which were in contrast with the effects of higher input frequency and feed flow rate. The commercial TiO_2 (Degussa P25), TiO_2 , and 1%Pt/ TiO_2 prepared by sol-gel method were used as photocatalysts. The presence of all studied photocatalysts increased the C_2H_4 and O_2 conversions, as well as CO_2 selectivity, in the following

order: 1%Pt/TiO₂ > TiO₂ > Degussa P25. The synergistic effect of photocatalysts presented in the plasma reactor was resulted from the activation of TiO₂ by the UV light generated from the plasma.

Tansuwan (2007) studied the epoxidation of ethylene in a low-temperature corona discharge system in the presence of different catalysts, including Ag/low-surface-area(LSA) α -Al₂O₃, Ag/high-surface-area(HSA) γ -Al₂O₃, Au-Ag/(HSA) γ -Al₂O₃, and Au/TiO₂. The results showed that Ag/(LSA) α -Al₂O₃ offered the highest selectivity for ethylene oxide, as well as the lowest selectivities for carbon monoxide and carbon dioxide. The selectivity for ethylene oxide increased with increasing applied voltage, but remained unchanged when frequency was varied within 300 to 500 Hz, and eventually decreased with the frequency over 500 Hz. The optimum Ag loading on (LSA) α -Al₂O₃ was found to be 12.5 wt.% with ethylene oxide selectivity of 12.98% at input voltage and frequency of 15 kV and 500 Hz, respectively.

Suwannabart (2008) studied the epoxidation of ethylene in a dielectric barrier discharge (DBD) system to find the optimum operating conditions. The results showed the highest ethylene oxide yield of 5.62% was obtained when an input frequency of 500 Hz and an applied voltage of 19 kV were used, with an O₂/C₂H₄ molar ratio of 1/1, a feed flow rate of 50 cm³/min, and an electrode gap distance of 10 mm. When comparing with the corona discharge system with 0.2 wt.% Au-12.5 wt.%Ag/(low-surface-area) α -Al₂O₃ catalyst exhibiting comparative good epoxidation performance, the DBD system still provided the better performance in terms of C₂H₄ conversion, C₂H₄O yield, and power consumption per C₂H₄O molecule produced.

2.4 Catalysts Used in Epoxidation of Ethylene

Ethylene can be catalytically converted into ethylene oxide with high selectivity over supported silver catalysts. The first commercial ethylene oxide production can be traced to Lefort's process in 1937 (Satterfield, 1991). Typically, a unique support for silver catalysts is alpha-alumina (α -Al₂O₃). Low-surface-area (LSA) α -Al₂O₃, possessing the surface area less than 1 m²/g, was commercially widely used as silver catalyst support. Unfortunately, this support showed poor silver

dispersion, which provided relatively low yield of ethylene oxide (Matar *et al.*, 1989). Interestingly, the addition of few ppms of chloride to gaseous reactant as moderator in the form of chlorine-containing hydrocarbon species, such as dichloroethane ($C_2H_4Cl_2$) and vinyl chloride (C_2H_3Cl), has been reported to significantly increase the selectivity for ethylene oxide by 15-20%, but at the same time, decrease the rates of ethylene oxide and carbon dioxide formation (Law *et al.*, 1942; Campbell *et al.*, 1984; Tan *et al.*, 1986; and Yeung *et al.*, 1998). The mechanism of chloride moderator is still in question that it has been attributed to geometric (Campbell *et al.*, 1984; Campbell *et al.*, 1985; and Campbell *et al.*, 1986), electronic (Tan *et al.*, 1986; and Lambert *et al.*, 2003), or both effects. Moreover, some previous research found that the alkali and transition metals, such as Cs and Cu, also provided the improvement of selectivity for ethylene oxide (Iwakura, 1985; and Bhasin, 1988). Recently, it was confirmed that copper-silver bimetallic catalysts could offer selectivity improvement compared with bare silver catalysts in the ethylene epoxidation (Jankowiak and Barteau, 2005).

The role of cesium was proposed that the presence of cesium could reduce the acidic sites on the support, resulting in suppressing the isomerization of ethylene oxide to acetaldehyde (Mao and Vannice, 1995; and Epling *et al.*, 1997). At the same time, cesium could however promote the direct combustion. The mechanism was that cesium could provide the additional electron to silver lattice, transferring to adsorbed oxygen. Finally, the adsorbed oxygen possessed excess highly electron density, benefiting the total oxidation of ethylene. Moreover, cesium addition could decrease the concentration of nucleophilic oxygen, which is responsible for carbon dioxide formation (Goncharova *et al.*, 1995). Therefore, in the presence of cesium added, the selectivity for ethylene oxide is enhanced by the suppression of the rate of ethylene oxide oxidation, resulting in the decrease in the rate of direct combustion. It, however, has been investigated for adding cesium in high-surface-area(HSA) $\alpha-Al_2O_3$ that selectivity for ethylene oxide was not enhanced, but the turnover frequency of ethylene oxidation, as well as the rates of ethylene oxide and acetaldehyde oxidation, were increased (Mao and Vannice, 1995).

In a previous work (Rojluechai *et al.*, 2006), the nominal 1wt.% Au/TiO₂ catalyst provided the highest selectivity for ethylene oxide with relatively low ethylene conversion. Moreover, the catalytic activity of Au catalysts was found depending upon the size of Au particles and also catalyst preparation methods. However, ethylene conversion obtained from the following catalysts, Ag/(HSA) γ -Al₂O₃, Au/TiO₂, and bimetallic Au-Ag/(HSA) γ -Al₂O₃, could not be detected at any temperature below 493 K. Even though the reaction temperature was raised up to 543 K, ethylene conversion was still low at 1-4%. Consequently, this limitation results in high energy consumption for catalyst activation at high temperature, which is a disadvantage for industrial application. The non-traditional catalysis technique is, therefore, expected to overcome this constraint. One of potential techniques is to combine the selective traditional catalysis and non-thermal plasma.

With the roles of gold in ethylene epoxidation, there are relatively confused points of view for existing literatures as follows. The effects of alloying silver with gold on the oxygen adsorption properties of Ag over a set of 15 wt.% bimetallic Ag-Au/ α -Al₂O₃ were studied (Kondaries and Verykios, 1996). The results showed that the presence of Au influenced the population and the activation energy of adsorbed oxygen species. Especially, when Au content increased, the molecular oxygen was more favorable in adsorption on Ag than atomic oxygen, which indicated by its lower activation energy of adsorption. Based on molecular oxygen theory, this adsorbed specie exhibited the vital role for ethylene oxide formation, whereas atomic oxygen was considered to be an unselective oxidant for partial oxidation (Kilty *et al.*, 1973). While other research group reported in the different way that the selectivity for ethylene oxide was observed at constant value up to approximately 10 wt.% Au content on the surface and decreased continuously at higher Au contents (Tories and Verikios, 1987). On the other hand, Geenen *et al.* (1982) reported that at the high Au loading, the selectivity for ethylene oxide decreased and rapidly dropped to zero, which was more rapidly dropped than Tories and Verikios' experiments. The discrepancies might originate from the various alloying catalyst preparation techniques (Tories and Verikios, 1987). In a previous study (Rojluechai *et al.*, 2006), the effect of alloying Ag with Au supported on

(HSA) γ - Al_2O_3 on the activity was investigated. It had been found that addition of small amount of Au can create the Au-Ag bimetallic catalyst, which enhanced the ethylene epoxidation, whereas at higher Au loading, the Au-Ag alloy can take place, leading to complete combustion. For this study, the optimum Ag to Au ratio was 13.18 to 0.63 wt.% at temperature range of 510-520 K. The ethylene conversion and selectivity for ethylene oxide were enhanced attributing to the existence of the bimetallic Au-Ag, which increased the new favorable molecular oxygen sites.

As mentioned about the poorly dispersed silver on (LSA) α - Al_2O_3 , that is why many researchers attempt to determine other alternative supports to provide the better dispersed silver and to enhance the activity of the ethylene epoxidation. Seyedmonir *et al.*, (1989) studied the activity and selectivity for ethylene oxide over well-dispersed Ag/ SiO_2 , Ag/ η - Al_2O_3 , and Ag/ TiO_2 in the presence and absence of $\text{C}_2\text{H}_4\text{Cl}_2$ (EDC) compared with those of poorly dispersed Ag/ α - Al_2O_3 . In the presence of 0.5 ppm EDC, the well-dispersed catalyst exhibited the selectivity for ethylene oxide less than the poorly dispersed catalyst, except Ag/ SiO_2 , due to the presence of secondary oxidation reaction occurring on these reactive supports. In contrast, the ethylene oxide selectivities of 17 and 55% were obtained over 4.4 and 7.6 nm Ag crystallites on SiO_2 , respectively, compared with 23% over 1 μm Ag crystallites on α - Al_2O_3 in the absence of EDC and CO_2 at 523 K.

Due to well-dispersed silver over (HSA) α - Al_2O_3 support (approximately 78-104 m^2/g), it has also been used as support for ethylene epoxidation, but it was poor support for this reaction, and only complete oxidation was obtained. The absence of ethylene oxide was induced by this support containing a certain amount of acidity, leading to secondary oxidation of ethylene oxide, oxidation of ethylene, and isomerization of ethylene oxide to acetaldehyde (Mao and Vannice, 1995).

TiO_2 also has some special properties, which are believed to enhance the catalytic activity of ethylene oxidation reaction. It has been known that titanium dioxide exhibits a strong metal-support interaction effect with group VIII noble metals and possesses the ability for oxygen migration from reduced support particles onto the surfaces of the metallic particles of the catalysts, which, in turn, promotes oxidative reactions (Holgado *et al.*, 1998). However, it was reported that silver

supported on TiO_2 showed zero ethylene oxide selectivity due to the isomerization of ethylene oxide to acetaldehyde on the support followed by the complete combustion (Seyedmonir *et al.*, 1989; Yong *et al.*, 1991).