

## Invention and evaluation of dental blade-and-needle remover box

Wanee Unwerawattana\*

**Unwerawattana W. Invention and evaluation of dental blade-and-needle remover box. Chula Med J 2005 Sep; 49(9): 527 - 41**

- Problem/Background** : *A disadvantage of needle remover is that it can be used only to remove a straight needle but not a screw needle. Also, a blade remover with T-like groove was difficult to use.*
- Objective** : *To study about feasibility, practicability, utility and acceptability of the new blade-and-needle remover box in dental personnels.*
- Design** : *Descriptive study.*
- Setting** : *Eleven departments of dentistry in research hospitals.*
- Material** : *A non-disposable aluminium box was made for removing blades and needles with two containers inside for receiving the blades and needles. The box had a side-door with a top wall which had two components, a blade remover on one side and a needle remover on the other.*
- Method** : *Representatives from eleven hospital Departments of Dentistry were given blade-and-needle remover boxes, one box for each hospital. Questionnaires were given to the dental personnel such as the dentist, dental assistant, dental nurse or healthcare worker who had used the box for at least one week. The researcher demonstrated how to use the box by VCD and live demonstration. The representatives took responsibility to demonstrate to their colleagues both by the VCD and live demonstration. The duration of the research was from March 11, 2005 to May 12, 2005. Out of eighty-five questionnaires distributed, and seventy-seven were answered and returned, a response rate of 90.59 %. The data from the research were finally analyzed.*

- Result** : *All baseline data such as gender, social position, age, occupational experience, frequency of blade removal and needle removal also were not statistically significantly different to intervention data such as understanding how to use the box, understanding from, capable of use, size and design of the box, problem of container, guideline for blade remover and needle remover and also their willingness to use the box. The only exception which showed that there was a statistically significant difference between the users who used the blade remover more than 10 times/week and those who were willing to use the box ( $p$ -value = .016) as following data; It was also founded that all of them always or usually used the box (100 %).*
- Conclusion** : *This study obviously showed that everyone who answered the questionnaire concluded that the blade-and-needle remover box is useful in their practice to reduce the risk or hazard from removing blades and needles. Although it has some disadvantages, the users were still satisfied and were trying to use it in their daily work.*
- Keywords** : *Blade remover, Needle remover, Blade-and-needle remover box.*

Reprint request: Unwerawattana W. Department of Dentistry, King Chulalongkorn Memorial Hospital, Bangkok 10330, Thailand.

Received for publication. May 25, 2005.

วรรณิ อันวีระวัฒนา. การประดิษฐ์และการประเมินผลการใช้งานของกล่องปลดมีดผ่าตัดและ  
ปลดเข็มฉีดยาทางทันตกรรม. จุฬาลงกรณ์เวชสาร 2548 ก.ย; 49(9): 527 - 41

**เหตุผลการวิจัย** : เนื่องจากกล่องปลดเข็มฉีดยาที่ใช้ยู่มีข้อเสียคือปลดได้เฉพาะเข็ม  
เสียบตรงแต่ไม่สามารถปลดเข็มหมุนเกลียว และกล่องปลดมีดผ่าตัด  
ออกแบบคล้ายร่องตัว T ใช้งานยาก

**วัตถุประสงค์** : เพื่อศึกษาความเป็นไปได้ในทางปฏิบัติ ความสะดวกในการใช้งาน  
ตลอดจนการยอมรับกล่องปลดมีดผ่าตัดและปลดเข็มฉีดยาแบบใหม่

**รูปแบบการวิจัย** : การศึกษาเชิงพรรณนา

**สถานที่ทำการศึกษา** : ฝ่ายทันตกรรมของโรงพยาบาลที่เข้าร่วมในโครงการวิจัย

**ตัวอย่าง** : กล่องปลดมีดผ่าตัดและเข็มฉีดยาที่ประดิษฐ์ขึ้นจากโลหะอลูมิเนียม  
โดยมีภาชนะ 2 อันรองรับมีดผ่าตัดและเข็มฉีดยาอยู่ภายในกล่อง  
กล่องมีฝาปิด-เปิดอยู่ด้านหนึ่ง ส่วนบนของกล่องประกอบด้วยอุปกรณ์  
2 ส่วน คือ อุปกรณ์ส่วนปลดมีดผ่าตัดด้านหนึ่งและอุปกรณ์ส่วนปลด  
เข็มฉีดยาอีกด้านหนึ่ง

**วิธีการ** : คือ สุ่มตัวอย่างแจกกล่องให้กับตัวแทนจากหน่วยงาน ทันตกรรม  
11 แห่ง โดยมีหลักเกณฑ์การเลือกผู้ใช้กล่องและตอบแบบสอบถาม  
ต้องเป็นบุคลากรทางทันตกรรมเช่น เป็นทันตแพทย์, ผู้ช่วยทันตแพทย์,  
ผู้ช่วยพยาบาล,คนงาน และต้องใช้งานกล่องอย่างน้อย 1 สัปดาห์  
จึงตอบแบบสอบถาม ผู้วิจัยได้สาธิตวิธีการใช้กล่องโดยใช้สื่อวีดิทัศน์  
และการสาธิตโดยตรงแก่ตัวแทนจากหน่วยงานต่าง ๆ และให้ตัวแทน  
ขยายผลวิธีการใช้งานกล่องต่อเพื่อนร่วมงานต่อไป ทั้งจากสื่อวีดิทัศน์  
และตัวแทนสาธิตโดยตรง ระยะเวลาการวิจัย 2 เดือน ตั้งแต่ 11 มี.ค.48-  
12พ.ค.48 ผู้วิจัยได้แบบสอบถามจำนวน 85 ชุด และได้รับการ  
ตอบกลับ จำนวน 77 ชุด คิดเป็นการตอบกลับ 90.59 %

- ผลการวิจัย** : ข้อมูลพื้นฐาน เช่น เพศ ตำแหน่ง อายุ ประสบการณ์ในอาชีพ ความถี่ในการปลดมิดผ้าตัด ตลอดจนความถี่ในการปลดเข็มฉีดยา จะไม่แตกต่างกันอย่างมีนัยสำคัญกับข้อมูลเกี่ยวกับสิ่งประดิษฐ์ เช่นความเข้าใจในการใช้กล่องปลดมิดผ้าตัดและปลดเข็มฉีดยา ความเข้าใจจากทางใด ระดับความสามารถในการใช้กล่อง ขนาดและรูปร่างของกล่อง การออกแบบกล่อง ปัญหาภาชนะที่รองรับมิดผ้าตัดและเข็มฉีดยาที่ใช้แล้ว หลักการของการปลดมิดผ้าตัด หลักการของการปลดเข็มฉีดยา และ ความเต็มใจที่จะใช้กล่องเป็นต้น ยกเว้นข้อมูลที่มีความแตกต่างอย่างมีนัยสำคัญ ระหว่างผู้ใช้กล่องปลดมิดผ้าตัด มากกว่า 10 ครั้งต่อสัปดาห์ กับ ผู้เต็มใจใช้กล่อง ค่า p-value = .016 และพบว่าผู้ใช้กล่องปลดมิดผ้าตัด มากกว่า 10 ครั้ง/สัปดาห์ จะเต็มใจใช้กล่องบ่อยเป็นประจำถึง 100 %
- สรุป** : จากการวิจัยศึกษาข้อมูลชี้ชัดว่าผู้ตอบแบบสอบถามทุกคนสรุปว่ากล่องปลดมิดผ้าตัดและปลดเข็มฉีดยา มีประโยชน์ต่อการทำงานเพื่อช่วยลดความเสี่ยงจากอันตรายระหว่างปลดมิดผ้าตัดและเข็มฉีดยา แม้ว่าจะมีข้อเสียเปรียบในบางประการ ผู้ใช้กล่องยังคงพึงพอใจ และพยายามใช้งานกล่องในการทำงานประจำวัน
- คำสำคัญ** : เครื่องมือปลดมิดผ้าตัด, เครื่องมือปลดเข็มฉีดยา, กล่องปลดมิดผ้าตัด และปลดเข็มฉีดยา

The original technique used to remove a used blade or needle was either removing it manually or by a device such as forceps or needle holders. This often causes a needle-stick injury or blade cut injury. During the removal of a used blade or a needle from a syringe, they can also be contaminated by the air and can spread more infection. Dental personnel may be directly infected by their patients who may have got a hazardous disease such as Hepatitis or HIV.<sup>(1-10)</sup> The waste product can also cause hazard to the healthcare workers. Nowadays we have invented a blade-and-needle remover box, designed as a square or a cylindrical box. A disadvantage of needle remover is that it can be used only to remove a straight needle but not a screw needle. Also, a blade remover with a T-like groove was difficult to use.

### The feature and the purpose of invention

The new blade-and-needle remover box consists of a blade remover and a needle remover. The action of a blade remover depends on a light pressured-force to lift up the end of a blade before removing the locking-blade. The action of a needle remover depends on loosening the screw of the syringe before removing it out. The two disposable containers inside receive used blades and needles until they are 3/4 full and then the users need to remove them.<sup>(1)</sup>

The objective of invention was to increase the efficiency of removing blades and needles while also providing an easy way of handling. The needle remover is designed to remove a straight needle and a screw needle.

### Duration of invention

The invention took eight months (from March

2004 to October 2004). The primary box was invented only for the removal of needles (some brand). The inventor tried to correct the error and improved the product to gain more standard by designing the necessary and important parts of the device such as a hinge which has a serrated end and fixed with the spring from sided-wall, as show in this invention box for removing every needle. (Figure 1-5)

Components of a blade remover are as follows:

- 1 = a groove available for locked-part area of the blade
- 2 = a shoulder or an ended of a groove to lift (raise) the blade
- 3 = a swing hinge for touching raised blade
- 4 = a big hole for used blades to fall into the container
- 5 = a plastic cover for users' body protection

Components of a needle remover are as follows:

- 6 = a parallel hole for turning the needle screw out
- 7 = a parallel hole for removing straight needle
- 8 = a parallel hole for removing screw needle
- 9 = a hinge with serrated end to fix a screw needle
- 10 = a spring which connects a hinge to its wall

### The perfect details of invention

Figure 1. shows a blade remover device. In application, a blade is to be placed on the groove (1) which is available for the locking-part area of the blade. Then using light pressure on the handle of the blade, the blade will be raised at the end of the groove (2) and closing the plastic cover (5), and will be further move the hinge (3) to serve the raised blade. Pulling the handle of the blade out (Figure 2), the blade will

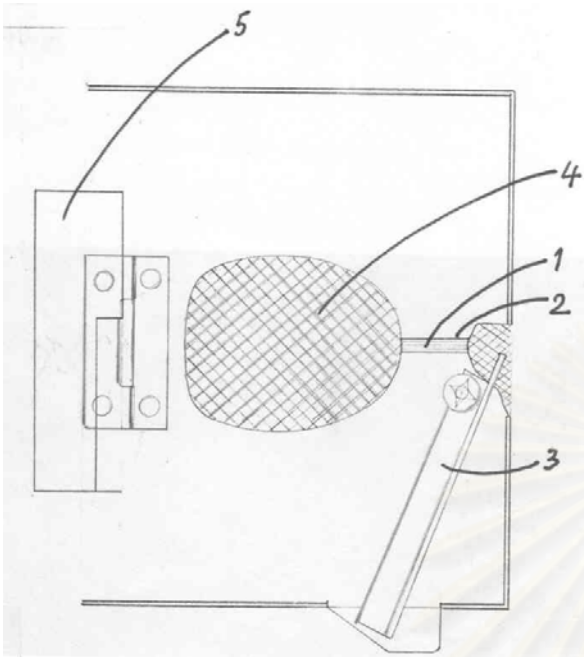

**Figure 1.** Shows a blade remover device.

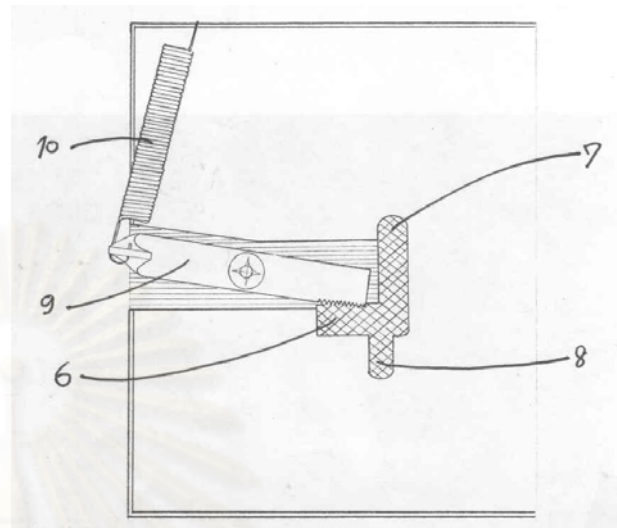

**Figure 3.** Shows a needle remover device.



**Figure 2.** Shows the moved hinge is served the raised blade and pulling the handle of the blade out.



**Figure 4.** Shows the screw needle is fixed by a serrated end hinge which was fixed by a sided spring.

be separated from the lock and then fall through a big hole (4) into the container.

Figure 3. shows a needle remover device. In case of removing a screw needle, it is removed by a

parallel hole (6). The screw needle is fixed by a serrated end hinge (9) which was fixed by a sided spring (10) (Figure 4). Turning the screw needle out from the non-disposable syringe approximately 7 rounds



**Figure 5.** Shows the loosened needle can be removed by a gentle force.

the needle will be loosened, and the loosened needle to another hole (8) and can be removed by a gentle force. Being removed, the needle will fall into the container. (Figure 5)

In order to remove a straight needle, it needs to be placed in the parallel hole (7) and will be removed by a gentle force, the needle will fall into the container.

#### **Advantages of the blade-and-needle remover**

1. It is designed to remove blades and both types of needle efficiently.
2. It is designed to reduce the risk of needle-stick injury and cutting-blade injury to exposed medical personnel; and to improve the management of infectious waste products for employees.
3. Being made out of aluminium, it is cheaper in the long run.

#### **Disadvantages and corrections of blade-and-needle remover**

1. Unskillful medical personnel need to learn how to use the remover. Facing new difficulties, they

return to the old technique. In order to solve this problem, a conference is needed to demonstrate how to use the remover in the right way. This will encourage the personnel to use to the boxes during their daily work.

2. The problem of lacking the right inside containers to receive the used blades and needles because it is a non-disposable box. To solve this problem, a compensating container found in our environment, such as a disposable plastic cup, is used for receiving the used blades and used needles. If it is full, remove it and contain it in a bigger container then close the lid and pack it in an infectious bag.

3. The boxes are hand-made. This limits both the quality and quantity of the product. It means the procedures of production are not all accurate (medium quality) and small amount of boxes can be produced. In the beginning, it was not well distributed among medical personnel. To solve the problem, the production needs to be industrialized, a step which will be based on the results of this pilot study.

This research was a descriptive study to test the invention of a blade-and needle remover. The objective of this study is to study about feasibility, practicability, utility and acceptability of the new blade-and-needle remover box in dental personnels.

#### **Material**

A non-disposable aluminium box was made for removing blades and needles with two containers inside for receiving blades and needles. The box had a side-door of which the top wall had two components which were a blade remover on one side and a needle remover on the opposite side.

## Method

Representatives from eleven departments of dentistry of sampled hospitals such as King Chulalongkorn Memorial Hospital, Oral and Maxillofacial Surgery Department Faculty of Dentistry Chulalongkorn University, Dental Institution - Ministry of Public Health, Tak-Sin Hospital, Hua-Shiew Hospital, Som-Dej Na Sriracha Hospital, Neurology Institution, Psychology Institution, Bumradnaradul Hospital, Chest Disease Institution – Ministry of Public Health, Public Health Center 6 of Bangkok Metropolitan. They were given a blade-and-needle remover, one for each institute. Questionnaires were later distributed to the dental personnel such as the dentist, dental assistant, or healthcare workers who used the box one week. The researcher demonstrated how to use the box by a VCD and live demonstrations. The representatives mostly were dental assistants and were responsible for showing their colleagues (dental assistant or healthcare worker) the VCD and conducting live demonstrations. The duration of this research was two months (from March 11, 2005 to May 12, 2005). Eighty-five questionnaires were distributed. Because it was depended on the amount of dental assistants or healthcare worker in each hospital and their willingness of using the box. Not only dental assistant but also healthcare worker were two-thirds of this target group (58 in 85). The seventy-seven questionnaires were answered, a 90.59 % response rate. The data from the research are as follows:

## Result

We collected data from the questionnaires and presented in the following tables and a figure.

Table 1 shows Fisher's Exact test, at  $p < 0.05$  no statistical difference of understanding how to use the remover according to gender, position, age, occupational experience, and frequencies of blade and needle removal. There was no statistical significant difference of understanding from and capable of using the box at the baseline data also. According to table 1, we suggested that understanding how to use the remover, understanding from or capable of using the remover were not depended on gender, position, age, occupational experience, frequency of blade and needle removal. That means every users understand of how to use the box, understand either from VCD or demonstration or both and capable of using the box. So the blade and needle remover is simple and easy to use.

Table 2 shows Fisher's Exact test, at  $p < 0.05$  no statistically significant difference of size of the box which is designed for working and problem of container in gender position, age, occupational experience, frequencies of blade and needle removal. The percentage levels in various baseline data were approximate data such as mentioned above. This table illustrates that the users are satisfied with the box and no statistically significant difference of size of the box, design for working and problem of container in various users.

Table 3 shows Fisher's Exact test, at  $p < 0.05$  no statistically significant difference of guideline of blade remover (lift and separate), guideline of needle remover (screw out and remove) and willingness to use the box in various users except that was statistically significant difference in the users who are willing to use and who have frequency of blade removed. The percentage between the two groups of



**Table 1.** Baseline data related to questions about understanding how to use the box, understanding from and capable of using the box.

	Understanding how to use the box			Understanding from			Capable of using the box		
	Good N(%)	Fair N(%)	P - value	Both VCD and demonstration N(%)	Either VCD or demonstration N(%)	P - value	Good N(%)	Fair N(%)	P - value
Gender									
Female	56(74.7 %)	19(25.3 %)	1.000	34(45.3 %)	41(54.7 %)	1.000	48(64.0 %)	27(36.0 %)	.539
Male	2(100.0 %)	0(0.0 %)		1 (50 %)	1(50 %)		2(100.0 %)	0(0.0 %)	
Social position									
Not a dentist	45(77.6%)	13(22.4 %)	.541	30(51.7 %)	28(48.3 %)	.066	39(67.2 %)	19(32.8 %)	.581
A dentist	13(68.4 %)	6(31.6 %)		5(26.3 %)	14(73.7 %)		11(57.9 %)	8(42.1 %)	
Age									
< = 40 yrs	40(75.5 %)	13(24.5 %)	1.000	26(49.1 %)	27(50.9 %)	.460	35(66.0 %)	18(34.0 %)	.800
> 40 yrs	18(75.0 %)	6(25.0 %)		9(37.5 %)	15(62.5 %)		15(62.5 %)	9(37.5 %)	
Occupational experience									
< = 10 yrs	33(75.0 %)	11(25.0 %)	1.000	21(47.7 %)	23(52.3 %)	.817	28(63.6 %)	16(36.4 %)	.814
> 10 yrs	25(75.8 %)	8(24.2 %)		14(42.4 %)	19(57.6 %)		22(66.7 %)	11(33.3 %)	
Frequency of blade removal (times/week)									
< = 10	43(74.1%)	15(25.9 %)	.768	26(44.8 %)	32(55.2 %)	1.000	36(62.1 %)	22(37.9 %)	.417
> 10	15(78.9 %)	4(21.1%)		9(47.4 %)	10(52.6 %)		14(73.7 %)	5(26.3 %)	
Frequency of needle removal (times/week)									
< = 10	25(83.3 %)	5(16.7 %)	.279	11(36.7 %)	19(63.3 %)	.248	20(66.7 %)	10(33.3 %)	1.000
> 10	33(56.9%)	14(73.7%)		24(51.1 %)	23(48.9 %)		30(63.8 %)	17(36.2 %)	

From Fisher's Exact test at p < 0.05

**Table 2.** Baseline data related to questions about size of box, design for working and problem of container.

	Size of the box				Design for working				Problem of container					
	All right		Not all right		Convenient		Not convenient		Have problem		Haven't problem		P - value	
	N (%)	N (%)	N (%)	N (%)	N (%)	N (%)	N (%)	N (%)	N (%)	N (%)	N (%)	N (%)	N (%)	P - value
<b>Gender</b>														
Female	65(86.7 %)	10(13.3 %)	1.000	61(81.3 %)	14(18.7 %)	1.000	29(38.7 %)	46(61.3 %)	.524					
Male	2(100.0 %)	0(0 %)		2(100.0 %)	0(0 %)		0(0 %)	2(100.0 %)						
<b>Social position</b>														
Not a dentist	52(89.7 %)	6(10.3 %)	.251	48(82.8 %)	10(17.2 %)	.737	22(37.9 %)	36(62.1 %)	1.000					
A dentist	15(78.9 %)	4(21.1 %)		15(78.9 %)	4(21.1 %)		7(36.8 %)	12(63.2 %)						
<b>Age</b>														
< = 40 yrs	46(86.8 %)	7(13.2 %)	1.000	42(79.2 %)	11(20.8 %)	.529	23(43.4 %)	30(56.6 %)	.138					
> 40 yrs	21(87.5 %)	3(12.5 %)		21(87.5 %)	3(12.5 %)		6(25.0 %)	18(75.0 %)						
<b>Occupational experience</b>														
< = 10 yrs	37(84.1 %)	7(15.9 %)	.502	35(79.5 %)	9(20.5 %)	.766	17(38.6 %)	27(61.4 %)	1.000					
> 10 yrs	30(90.9 %)	3(9.1 %)		28(84.8 %)	5(15.2 %)		12(36.4 %)	21(63.6 %)						
<b>Frequency of blade removal (times/week)</b>														
< = 10	51(87.9 %)	7(12.1 %)	.701	46(79.3 %)	12(20.7 %)	.497	22(37.9 %)	36(62.1 %)	1.000					
> 10	16(84.2 %)	3(15.8 %)		17(89.5 %)	2(10.5 %)		7(36.8 %)	12(63.2 %)						
<b>Frequency of needle removal (times/week)</b>														
< = 10	24(80.0 %)	6(20.0 %)	.175	24(80.0 %)	6(20.0 %)	.769	13(43.3 %)	17(56.7 %)	.474					
> 10	43(91.5 %)	4(8.5 %)		39(83.0 %)	8(17.0 %)		16(34.0 %)	31(66.0 %)						

From Fisher's Exact test at p &lt; 0.05

**Table 3.** Baseline data related to questions about guideline of blade remover, guideline of needle remover and willingness to use the box.

	Guideline of blade remover			Guideline of needle remover			Willingness to use the box			P - value	
	Lift and Separate			Screw out and remove			Always, usually use				Sometimes use
	Yes N (%)	No N (%)	P - value	Yes N (%)	No N (%)	P - value	Always, usually use N (%)	Sometimes use N (%)	P - value		
<b>Gender</b>											
Female	74(98.7 %)	1(1.3 %)	1.000	66(88.0 %)	9(12.0 %)	1.000	60(80.0 %)	15(20.0 %)	1.000		
Male	2(100.0 %)	0(0.0 %)		2(100.0 %)	0(0.0 %)		2(100.0 %)	0(0.0 %)			
<b>Social position</b>											
Not a dentist	57(98.3 %)	1(1.7 %)	1.000	51(87.9 %)	7(12.1 %)	1.000	46(79.3 %)	12(20.7 %)	.750		
A dentist	19(100.0 %)	0(0.0 %)		17(89.5 %)	2(10.5 %)		16(84.2 %)	3(15.8 %)			
<b>Age</b>											
< = 40 yrs	52(98.1 %)	1(1.9 %)	1.000	46(86.8 %)	7(13.2 %)	.712	42(79.2 %)	11(20.8 %)	.765		
> 40 yrs	24(100.0 %)	0(0.0 %)		22(91.7 %)	2(8.3 %)		20(83.3 %)	4(16.7 %)			
<b>Occupational experience</b>											
< = 10 yrs	43(97.7 %)	1(2.3 %)	1.000	40(90.9 %)	4(9.1 %)	.486	36(81.8 %)	8(18.2 %)	.777		
> 10 yrs	33(100.0 %)	0(0.0 %)		28(84.8 %)	5(15.2 %)		26(78.8 %)	7(21.2 %)			
<b>Frequency of blade removal (times/week)</b>											
< = 10	58(100.0 %)	0(0.0 %)	.247	49(84.5 %)	9(15.5 %)	.102	43(74.1 %)	15(25.9 %)	.016		
> 10	18(94.7 %)	1(5.3 %)		19(100.0 %)	0(0.0 %)		19(100.0 %)	0(0.0 %)			
<b>Frequency of needle removal (times/week)</b>											
< = 10	30(100.0 %)	0(0.0 %)	1.000	24(80.0 %)	6(20.0 %)	.142	22(73.3 %)	8(26.7 %)	.245		
> 10	46(97.9 %)	1(2.1 %)		44(93.6 %)	3(6.4 %)		40(85.1 %)	7(14.9 %)			

From Fisher's Exact test at p < 0.05

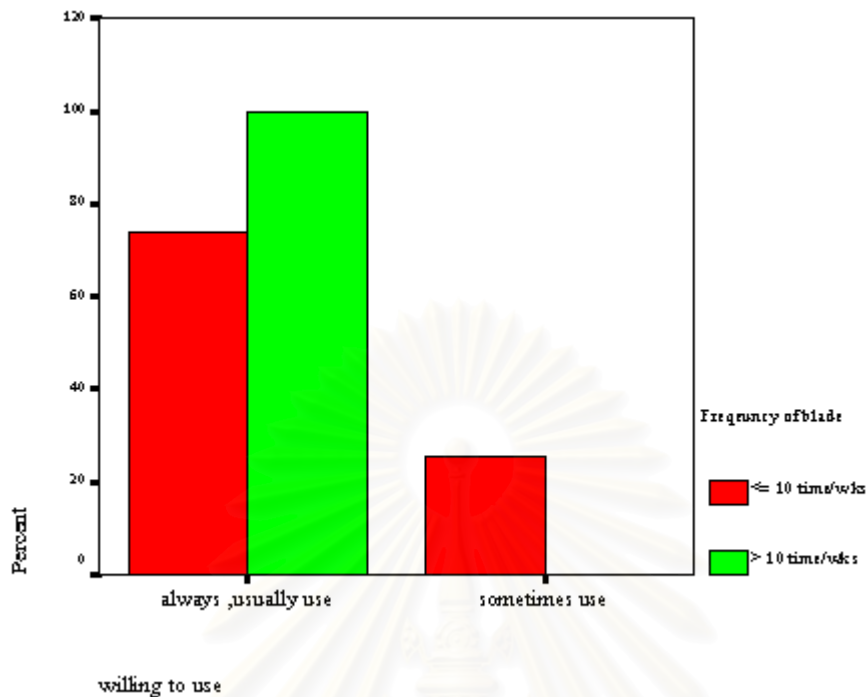

**Figure 6.** Shows the users who used the blade removal more than 10 times/week and were always willing to use it.

users who have frequency of blade removal less than and equal 10 times/week and more than 10 times/week were 74.1 % and 100.0 %, respectively. That is quite a wide range. As well as it was clear that every users who have frequency of blade removed more than 10 times/week always or usually willing to use the remover. It was obviously showed in bar-chart. (Figure 6)

Although table 1. 2 and 3 show no statistical difference of invention data (the questions from the questionnaires) and various baseline data except only one relation which was statistically difference of the user who are willing to use the box and who have frequency of blade removal ( $p$ -value = .016). From all tables we also illustrated that most of the users understand how to use the box and are capable of using it. They are satisfied with the size and the design of the box including understanding the guideline of

both the blade remover and the needle remover. Lastly, they always plan to use it. Everyone who answered the questionnaire concluded that the blade and needle remover box is useful in practice to reduce risk or hazard from removing the blades and needles.

## Discussion

Centers for Disease Control and Prevention (CDC) defined the term universal precautions as a set of precaution designed to prevent transmission of human immunodeficiency virus (HIV), hepatitis B virus (HBV), and other blood borne pathogens in health care settings.<sup>(1)</sup> Under universal precautions, blood and saliva (in dentistry) of all patients are considered potentially infectious for HIV, HBV, and other blood borne pathogens. Applied universal precautions means that the same infection control procedures for any given dental procedure must be used for all patients.

The infection control guidelines include appropriate procedures to protect dental patients as well as all dental healthcare workers whether employees or employers from occupational transmission of infectious diseases in dental office.<sup>(1-2)</sup> Percutaneous injuries should be prevention of these incidents by assessing safer devices and work practices. After a needle-stick exposure to an infected patient, a healthcare worker's risk of infection depends on the pathogen involve immune status of the worker, the severity of the needle-stick injury, and the availability and use of appropriate post-exposure.<sup>(3)</sup> In 1995 Shapiro CN<sup>(4)</sup> reported that about one-third to one-half of persons with acute HBV infection develop symptoms of hepatitis such as jaundice, fever, abdominal pain. Most acute infections resolve, but 5 % to 10 % of patients develop chronic infection with HBV that carries 20 % lifetime risk of dying from cirrhosis and 6 % risk of dying from liver cancer. In 1998 CDC<sup>(5)</sup> reported that HCV infection often occurs with no symptoms or only mild symptoms. But unlike HBV, chronic infection develops in 75 % patients, with active liver disease developing in 70 %. Of the patients with active liver disease, 10 % to 20 % develop cirrhosis, 5 % develop liver cancer. In 1994 Gerberding<sup>(6)</sup> and in 1999 Ippolito et al.<sup>(7)</sup> reported that data were combined from more than 20 worldwide prospective studies of healthcare worker exposed to HIV-infected blood through a percutaneous injury to estimate the rate of HIV transmission. In all, 21 infections followed 6,498 exposures for an average rate of 0.3 % per injury. Earlier studies<sup>(8-14)</sup> showed that approximately 38 % injuries occurred during the use, and 42 % after the use and before disposal.

In 1991, McCormick et al,<sup>(15)</sup> Yassi and McGill<sup>(16)</sup> showed that earlier studies of needle-stick injuries 10 % to 25 % occurred when recapping a used needle.

Needle-stick injuries and sharp instrument injuries are an important and continuing cause of exposure to serious and fatal diseases among healthcare workers.<sup>(5,17)</sup> Greater collaborative efforts by all stakeholders are needed to prevent needle-stick injuries and the tragic consequences. Such efforts are best accomplished through a comprehensive program that addresses institutional, behavioral, and development that contribute to the occurrence of needle-stick injuries in healthcare workers.

From this research study, some users suggested that the blade-and-needle remover box was not practical because of the blade remover device was on the opposite side of a top wall. It should be designed on a side-door of a top wall for the boxes were not removed. According to this design, the users are capable for removing both blade and needle at only one position. This suggestion was a good idea for the researcher to correct the later boxes to gain more practical. The other suggestion was the movable box which it should be fixed by screw or locking – part to increase stability of the box. The lastly suggestions were problem of lacking of containers and problem of limitation of infection control of some component part. It couldn't be sterilized in an autoclave, but it was cleaned by cold sterilization. The researcher gathered these suggestions to correct product improvements to gain more standard and more practical.

The author would like to suggest the blade-and-needle remover box to avoid sharp instrument injuries. This protection helps save healthcare workers and saves a lot of costs for post-exposure treatment. It is time for healthcare workers to practice carefully and to use devices during daily work to reduce risks of sharp instrument injuries.

### Conclusion

This study obviously showed that everyone who answered the questionnaire concluded that the blade-and-needle remover box is useful in their practice to reduce the risk or hazard from removing blades and needles. Although it has some disadvantages, i.e. the lack of containers and non-accuracy of hand-made product, but most of the users were still satisfied with them and would be willing to use the boxes for their safety.

### Acknowledgements

The author would like to thank Lions Club of Bangkok (Bualuang) District 310C Thailand which supported financial for this research study and Mr. Srivai Plangpranate who advised the author and helped this invention successfully. Miss Korakot Rochanabha our dental assistant who helped collecting data during study. Lastly, Mr. Paiboon Eiaton, Mr. Somyos Leecharoen who produced demonstrated VCD.

### References

1. Office Safety & Asepsis Procedures Research Foundation. Infection Control In Dentistry Guidelines [on line] 1997 [cited 2005 May 25]; Available from: <http://www.osap.org/resources/IC/icguide.pdf>
2. MillerCH, Palenik CJ. Sterilization,disinfection, and asepsis in dentistry. In: Block SS, ed. Disinfection, Sterilization, and Preservation. 5<sup>th</sup> ed. Philadelphia: Lippincott Williams & Wilkins, 2001: 1049-68
3. Sagoe-Moses C, Pearson RD, Perry J, Jagger J. Risks to health-care workers in developing countries. *New England Journal of Medicine*. 2001 Aug; 345(7):538-41
4. Shapiro CN. Occupational risk of infection with hepatitis B and hepatitis C virus. *Surg Clin North Am* 1995 Dec;75(6):1047-56
5. Centers for Disease Control and Prevention (CDC). Recommendations for prevention and control of hepatitis C virus (HCV) infection and HCV-related chronic disease. *MMWR Recomm Rep* 1998 Oct 16; 47(RR-19):1-39
6. Gerberding JL. Incidence and prevalence of human immunodeficiency virus, hepatitis B virus, hepatitis C virus, cytomegalovirus among health care personnel at risk for blood exposure: final report from a longitudinal study. *J Infect Dis*. 1994 Dec; 170(6):1410-7
7. Ippolito G, Puro V, Heptonstall J, Jagger J, DeCarti G, Petrosillo N. Occupational human immunodeficiency virus health care workers: worldwide cases through September 1997. *Clin Infect Dis* 1999 Feb; 28(2):365-83
8. Centers for Disease Control and Prevention (CDC). NIOSH Alert; Preventing Needlestick Injuries in Health Care Setting.[online] 1999 [cited 2005 May 17]; Available from: <http://www.cdc.gov/niosh/homepage.html>.
9. Qlicksmart Scalpel Blade Remover – Flask version.

- Australian Design Awards [online] 2005 [cited 2005 May 17]; Available from: www.Designawards.com.au/ADA/97-98
10. Needlestick Prevention. Safety and Health Topics [online] 2003 [cited 2005 May 17]; Available from: www.osha.gov
11. Jagger J, Balon M. Suture Needle and Scalpel Blade Injuries. AEP [online] 1995 [cited 2005 May 17]; Available from: www.healthsystem.Virginia.edu/internet/epinet/index 13. cfm
12. Needlestick Injuries. OSH Answers [online] 2005 [cited 2005 May 17]; Available from: www.ccohs.ca/oshanswers/diseases/needlestick\_injuries.
13. McCormick RD, Maki DG. Epidemiology of needle-stick injuries in hospital personnel. Am J Med 1981 Apr; 70(4):928-32
14. Ruben FL, Norden CW, Rockweel K, Hruska E. Epidemiology of accidental needle-puncture wounds in hospital workers Am J Med Sci 1983 Jul-Aug; 286(1):26-30
15. McCormick RD, Meisch MG, Ircink FG, Maki DG. Epidemiology of hospital sharps injuries: a 14 -year prospective study in the pre-AIDS and AIDS eras. Am J Med 1991 Sep 16; 91(3B):301S-307S
16. Yassi A, McGill ML, Khokhar JB. Efficacy and cost-effectiveness of a needleless intravenous access system. Am J Infect Control 1995 Apr; 23(2):57-64
17. Bell DM. Occupational risk of human immunodeficiency virus infection in healthcare workers: an overview. Am J Med 1997 May 19; 102(5B):9-15