

CHAPTER IV

RESULTS AND DISCUSSION

In this research, CPS used as a sulfur donor type vulcanizing agent, was prepared from the reaction of cardanol and elemental sulfur. Three parameters; reaction temperature, solvent and reaction time, were studied. CPS including other common additives was then mixed with natural rubber sheet. The non-productive compound was prepared by using a banbury. The vulcanization ingredients comprising accelerator, sulfur and CPS were mixed with non-productive compounds by a two-roll mill. The amount of CPS was varied to study the effect of CPS on vulcanizing the rubber compounds. Finally, the rubber compounds were determined, and the vulcanization characteristics and the mechanical properties of rubber compounds were investigated.

4.1 Preparation of Cardanol Polysulfide (CPS)

4.1.1 Effect of Reaction Temperature and Solvent on Preparation of CPS

The effect of reaction temperatures from 110 to 185 °C on the sulfur content in prepared CPS was studied, using toluene, propylene glycol or non-solvent as a solvent, using cardanol of 70 g, elemental sulfur of 40 g, and reaction time of 2 hrs.

Table 4.1 shows the effect of reaction temperature and solvent on the amount percentage of sulfur in CPS. The reaction at 140 °C and no solvent was found to give the largest amount of sulfur in CPS. It can be explained that an increase in temperature, results in an increase in the number of free radicals leading to an increase the rate of polymerization. However when the reaction temperature at 160 °C was used it could not be controlled because the mixture was too viscous to stir. And if there is no solvent diluting the reactant, the most concentrated reaction mixture, causing high wieght percent of sulfur content in CPS (24 %wt).

Table 4.1 Effect of reaction temperature and solvent on the %wt of sulfur content in CPS: reaction time = 2 hrs

Temp. (°C)	solvent	%wt of sulfur content	Remark
110	toluene	10	-
120	no solvent	17	-
140	no solvent	24	-
160	no solvent	-	The reaction cannot reach 2 hrs because the mixture was too viscous to stir.
185	Propylene glycol	10	-

4.1.2 Effect of Reaction Time on Preparation of CPS

It can be seen from Figure 4.1 that when the reaction time increases from 2 to 3 hrs, the sulfur content in CPS increases from 24 %wt to 28 %wt. Insignificant difference of sulfur content in CPS is found for the reaction time in a range of 3 to 5 hrs. This indicates that the completed reaction occurs within 3 hrs. Thereof, the reaction time of 3 hrs and temperature of 140 °C were chosen for further experiment. Figure 4.1 shows the amount of sulfur in CPS as a function of reaction time, using reaction temperature of 140 °C.

ศูนย์วิทยทรัพยากร
จุฬาลงกรณ์มหาวิทยาลัย

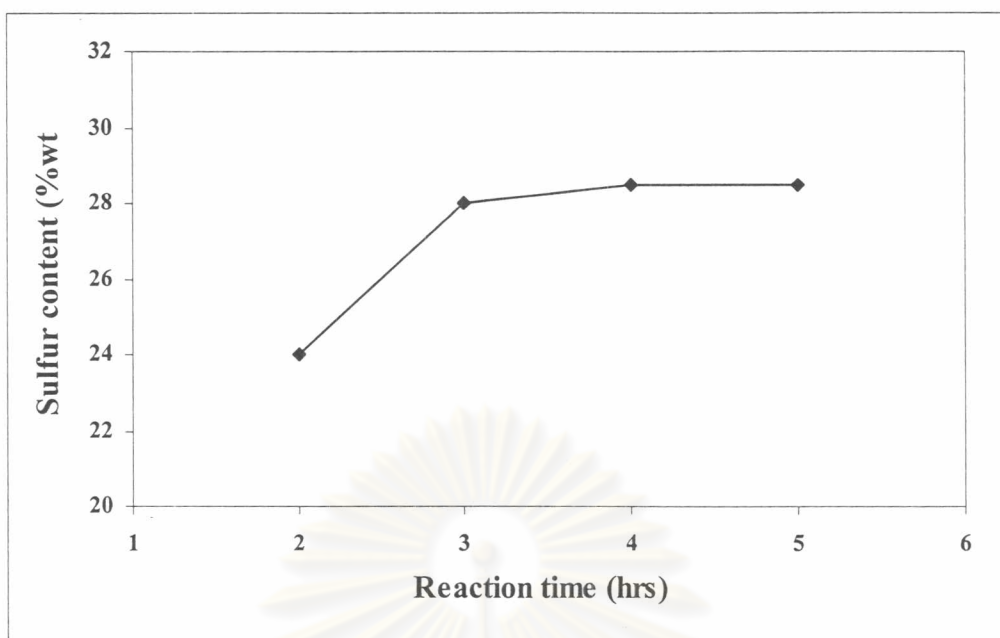
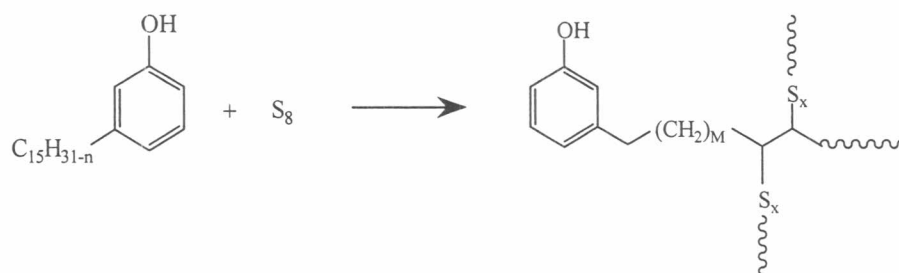

Figure 4.1 Effect of reaction time on the amount of sulfur content in CPS:
cardanol 70 g, elemental sulfur 40 g and reaction temperature 140 °C.

In the study of Radeemada's work [25], she reported that the vulcanizing agent from CNSL has 30 %wt of sulfur. For this research, the vulcanizing agent from cardanol has 28 %wt of sulfur. From the comparison indicated that insignificant difference of %wt of sulfur. Consequently, cardanol can react with elemental sulfur as well as CNSL under the same conditions.

4.2 Characterization of CPS

Figure A.3-A.12 show FT-IR, $^1\text{H-NMR}$ and $^{13}\text{C-NMR}$ spectra of cardanol and CPS. From form the difference between Figure A.7 and A.8 ($^1\text{H-NMR}$ spectra of cardanol and CPS, respectively), it indicates that there are less double bonds in alkyl chain in CPS than in cardanol. $^1\text{H-NMR}$ illustrated that olefinic protons (4.85-5.95 ppm) of CPS mostly disappear. Thus, CPS obtained from the reaction of cardanol and S_8 may have sulfur addition of some double bonds of a side chain of cardanol. The reaction and possible structure of CPS are shown below.



S_x may be a linear linkage of sulfur atom, such as



and also



It is believed that CPS is a complex mixture of sulfide resin, comprising mono-, di- and polysulfide linkage [21-24].

4.3 Effects of CPS in Rubber Compounds on Vulcanization Characteristics

Normally, vulcanizing agents influence the vulcanization characteristics such as optimum cure time (t_{90}), delta torque, etc. Moreover, CPS may be used as sulfur donor in place of sulfur (S_8) with the some required level of sulfur (2 %wt) in the vulcanization process. The amount of sulfur donor, which may be compounded with the rubber, is sufficient to provide an equivalent amount of sulfur as if sulfur itself was used. Effect of CPS in rubber compounds on vulcanization characteristics were studied using Monsanto rheometer MDR2000 according to ASTM D 2084-95 [31] at vulcanizing temperature 150 °C for 30 min and arc 0.5°. The details of all calculated data are presented in Appendix B and the vulcanization curves of rubber compounds are illustrated in Appendix C. The data of vulcanization characteristics are shown in Table 4.2.

Table 4.2 Vulcanization characteristics of rubber compounds

Compounds	Min τ	Max τ	Delta τ	T ₉₀	Rate
A	1.21	9.50	8.30	5.65	0.68
B	1.14	8.87	7.74	5.71	0.58
B1	1.16	9.44	8.29	5.43	0.46
B2	1.11	9.61	8.50	5.26	0.42
B3	1.08	10.32	9.24	5.19	0.41
C	1.22	8.82	7.60	6.20	0.53
C1	1.12	9.16	8.05	6.07	0.51
D	1.21	6.79	5.58	6.27	0.51
D1	1.05	8.81	7.76	6.32	0.46
E	0.93	8.40	7.47	6.40	0.37
E1	0.89	8.72	7.83	5.82	0.51
E2	0.88	8.78	7.90	5.57	0.50
E3	0.89	8.91	8.02	5.18	0.61

4.3.1 Vulcanization Characteristics of Rubber Compounds A-E (using CPS in place of sulfur by controlling total sulfur at 2 phr)

The effects of CPS on vulcanization characteristics and vulcanization curve, when using CPS in place of sulfur were determined by rheometry. The results were compared between rubbers containing CPS with the total sulfur of 2 phr (compounds B1, C1, D1 and E) and rubbers without CPS (compounds A, B, C and D).

4.3.1.1 Extent of Crosslinking

Figure 4.2 illustrates the delta torques of rubber compounds A-E. The delta torque or the extent of crosslinking is represented as of the degree of crosslinking. It can be seen from Figure 4.2 that the delta torque of rubbers containing CPS are more elevated than that of rubbers without CPS. This indicates that CPS can liberate sulfur to crosslink with the molecules of rubbers, hence the degree of crosslinking was found to increase.

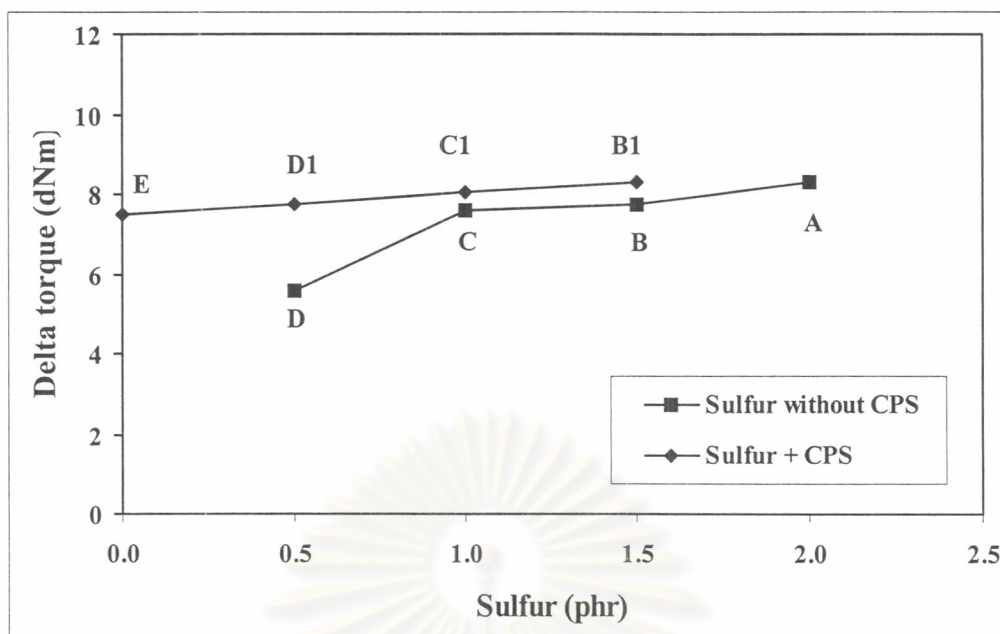

Figure 4.2 Delta torque of compounds A-D, and B1-E of rubber containing various concentrations of CPS and elemental sulfur of 0 to 2 phr.

4.3.1.2 Optimum Cure Time (t_{90})

The effect of CPS and elemental sulfur as the optimum cure time and vulcanization curves of rubber were compared. The results are shown in Figure 4.3.

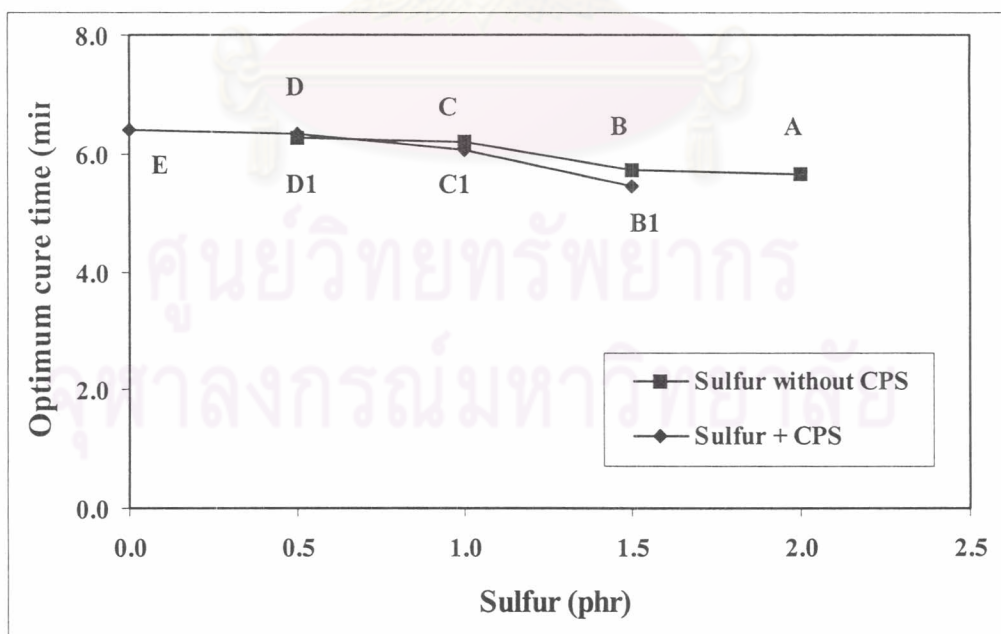

Figure 4.3 Optimum cure time of compounds A-D, and B1-E of rubber containing various concentrations of CPS and elemental sulfur of 0 to 2 phr.

From Figure 4.3, compound E (rubber containing only CPS) has a long optimum cure time. On the other hand, compound A (rubber containing only sulfur) was found to give a short optimum cure time. This is because large amount of CPS resulted in the low rate of vulcanization, leading to the long optimum cure time.

4.3.2 Vulcanization Characteristics of Rubber Compounds in Series B (using CPS combined with sulfur)

The vulcanization characteristics of rubber compounds in series B were investigated in order to study the effect of CPS when CPS combined with sulfur was used. The amount of CPS was varied from 0-6 phr and the amount of sulfur was kept constant at 1.5 phr. The data are presented in Table 4.2.

4.3.2.1 Extent of Crosslinking

Figure 4.4 shows the extent of crosslinking of a series B of rubbers containing various concentrations of CPS and elemental sulfur of 1.5 phr. It can be seen that the extent of crosslinking of series B slightly increases with an increase of the amount of CPS.

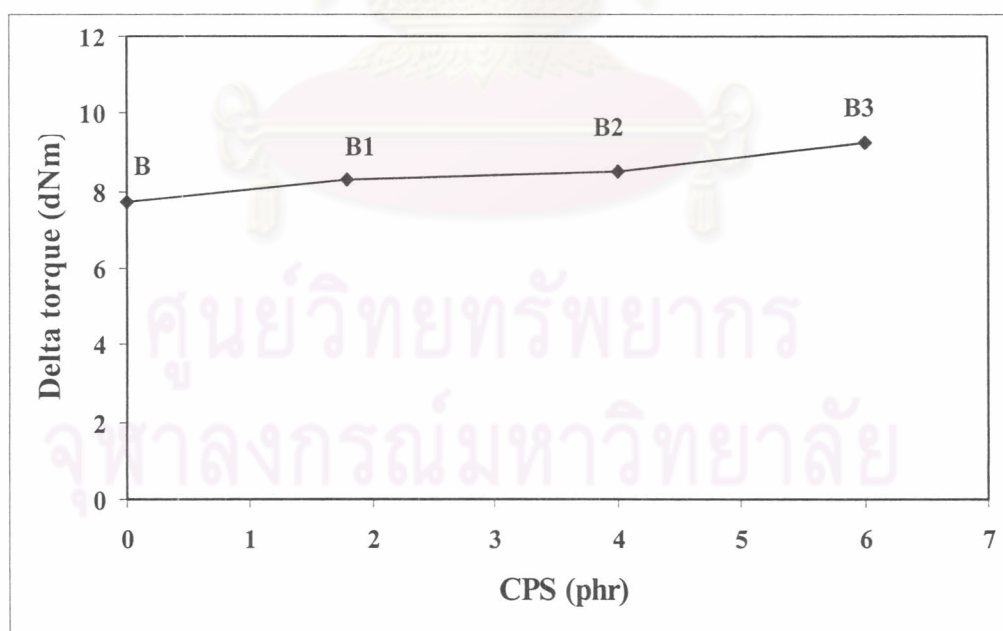

Figure 4.4 Delta torque of series B of rubbers containing various concentrations of CPS and elemental sulfur of 1.5 phr.

4.3.2.2 Optimum Cure Time (t_{90})

From Figure 4.5, the optimum cure time reduced when the amount of CPS increased. As vulcanization behavior of CPS that was observed in section 4.3.1.2, it can be explained for compounds B, B1, B2 and B3 that when the amount of CPS increased, the onset of vulcanization occurred. The rate of vulcanization becomes faster, resulting in shorter optimum cure time.

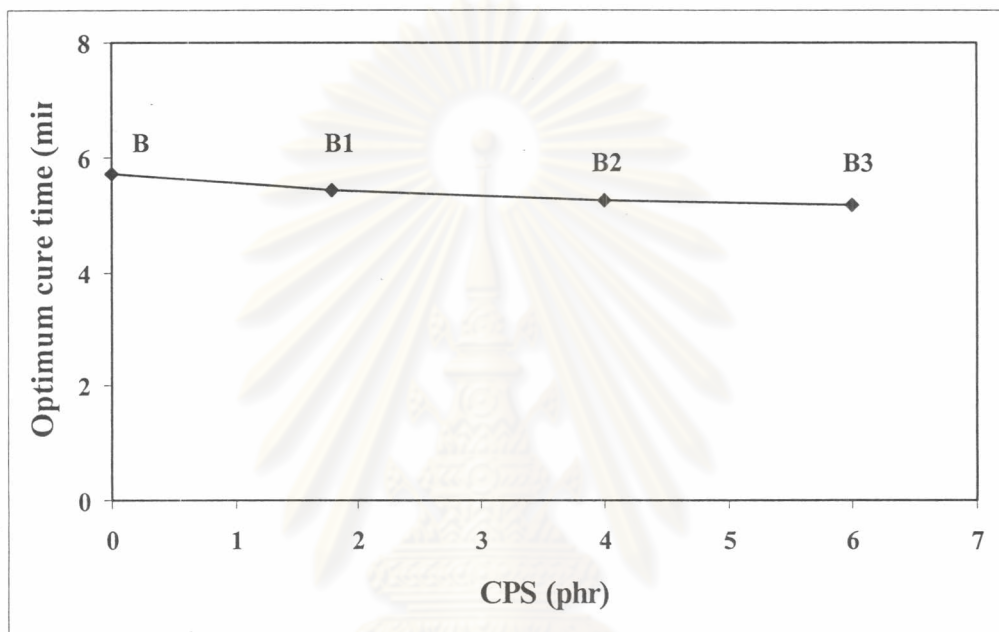

Figure 4.5 Optimum cure time of series B of rubbers containing various concentrations of CPS and elemental sulfur of 1.5 phr.

4.3.3 Vulcanization Characteristics of Rubber Compounds in Series E (rubbers containing only CPS)

The vulcanization of rubbers containing only CPS was studied. The effects of CPS of rubber compounds in series E on vulcanization characteristics were investigated and the data are illustrated in Table 4.2.

4.3.3.1 Extent of Crosslinking

The delta torque of rubbers containing only CPS in series E are shown in Table 4.2 and Figure 4.6. It can be seen that the extent of crosslinking of rubber compounds in series E increases when the amount of CPS increases. The reason of a change in the extent of crosslinking due to CPS are previously mentioned.

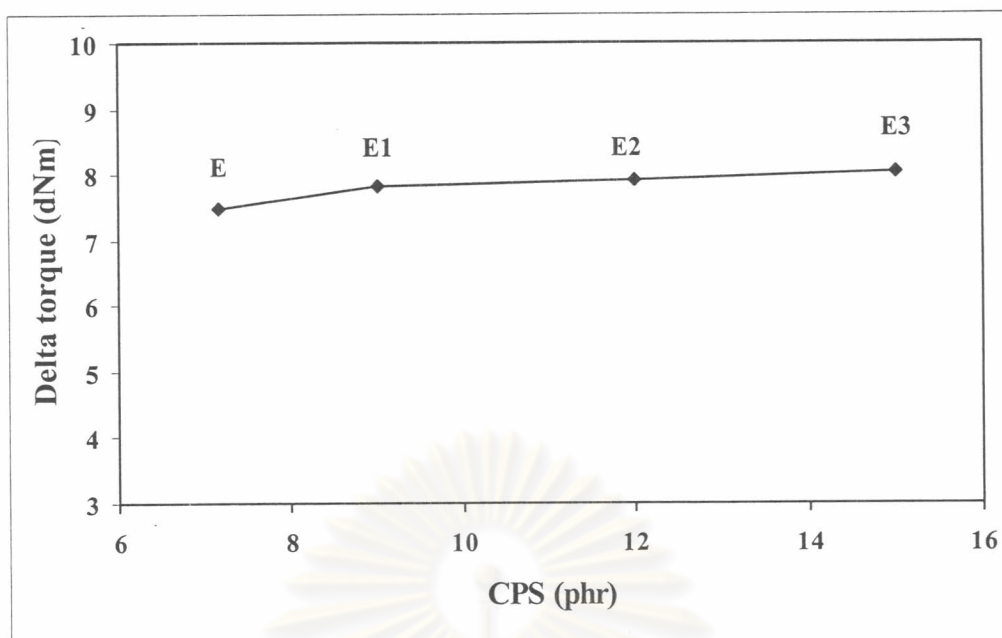

Figure 4.6 Delta torque of series E of rubbers containing various concentrations of CPS of 7.14 to 15 phr.

4.3.3.2 Optimum Cure Time (t_{90})

The optimum cure time of rubber compounds in series E as shown in Figure 4.7 that the optimum cure time of rubber compounds in series E decreased, as the amount of CPS raised. It can be observed that this result is quite similar to those of series B. This indicates that when no effect from sulfur, CPS can reduce the cure time because it reaches the onset of vulcanization at an early state. It is confirmed that under the appropriate conditions, the cure time can be reduced by CPS.

ศูนย์วิทยทรัพยากร
จุฬาลงกรณ์มหาวิทยาลัย

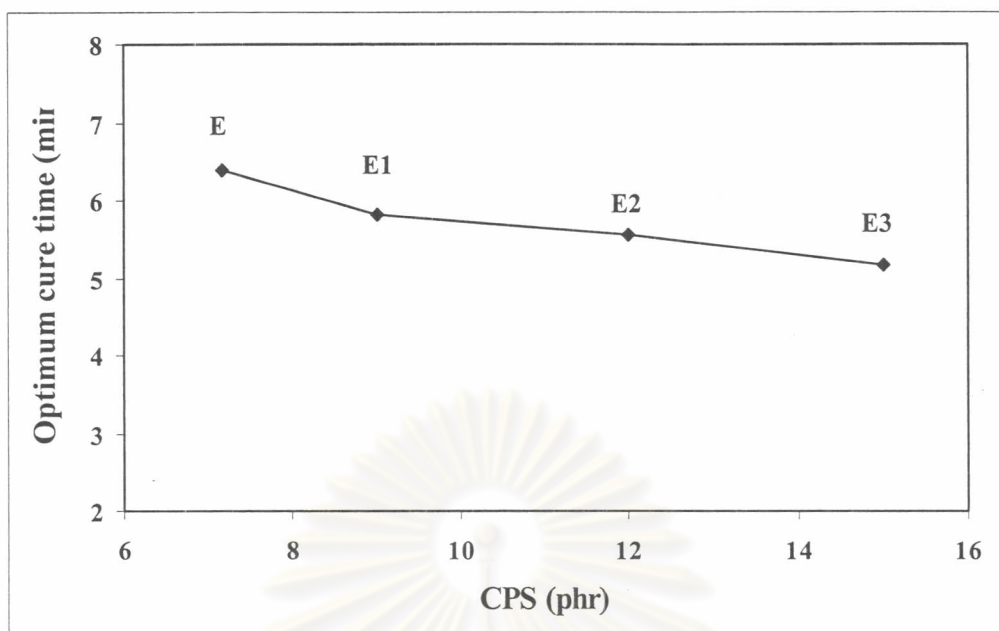

Figure 4.7 Optimum cure time of series E of rubbers containing various concentrations of CPS of 7.14 to 15 phr.

4.4 Mechanical Properties of Rubber Compounds

Mechanical properties, such as tensile properties, hardness and rebound resilience of rubber compounds were investigated, using CPS three systems, i.e. using CPS in place of sulfur, using CPS combined with sulfur and using only CPS for vulcanization. The details of all data calculated are shown in Appendix D. Table 4.3 shows values of tensile strength, elongation, modulus 500%, hardness and rebound resilience.

ศูนย์วิทยทรัพยากร
จุฬาลงกรณ์มหาวิทยาลัย

Table 4.3 Effect of CPS content on the mechanical properties of rubber compounds

Compounds	Tensile strength (MPa)	Elongation at break (%)	Modulus 500% (MPa)	Hardness (Shore-A)	Rebound resilience (W/mm)
A	24.18	613.18	15.96	46.40	79.8
B	24.07	619.77	14.32	44.80	76.8
B1	26.04	633.32	13.83	46.45	80.1
B2	24.79	643.92	13.71	46.85	82.7
B3	23.98	679.68	13.36	48.90	83.1
C	23.62	635.08	14.16	43.05	74.4
C1	24.66	645.07	12.30	45.75	79.1
D	21.86	643.50	13.43	37.00	69.8
D1	23.69	657.16	12.09	44.55	78.7
E	14.81	665.10	9.51	43.70	69.5
E1	15.30	672.32	10.13	45.25	70.4
E2	16.35	677.43	11.32	45.90	76.5
E3	17.50	688.80	11.82	46.65	78.0

4.4.1 Mechanical Properties of Compounds A-E (using CPS in place of sulfur by controlled total sulfur at 2 phr)

The effect of CPS on the mechanical properties of rubbers containing CPS when total sulfur was controlled at 2 phr and rubbers without CPS (compounds A-E) were studied. The results were compared between rubbers containing CPS (compounds B1, C1, D1 and E) and rubbers without CPS (compounds A, B, C and D).

4.4.1.1 Tensile Properties

The effect of CPS components on tensile properties of rubber compounds were compared between rubbers containing CPS (compounds B1, C1, D1 and E) and rubbers without CPS (compounds A, B, C and D). The results are shown in Figures 4.8, 4.9 and 4.10.

From Figure 4.8, tensile strengths of rubbers containing CPS are higher than those of rubbers without CPS. The tensile strength increases because the degree of crosslinking increases from sulfur, which was liberated from CPS.

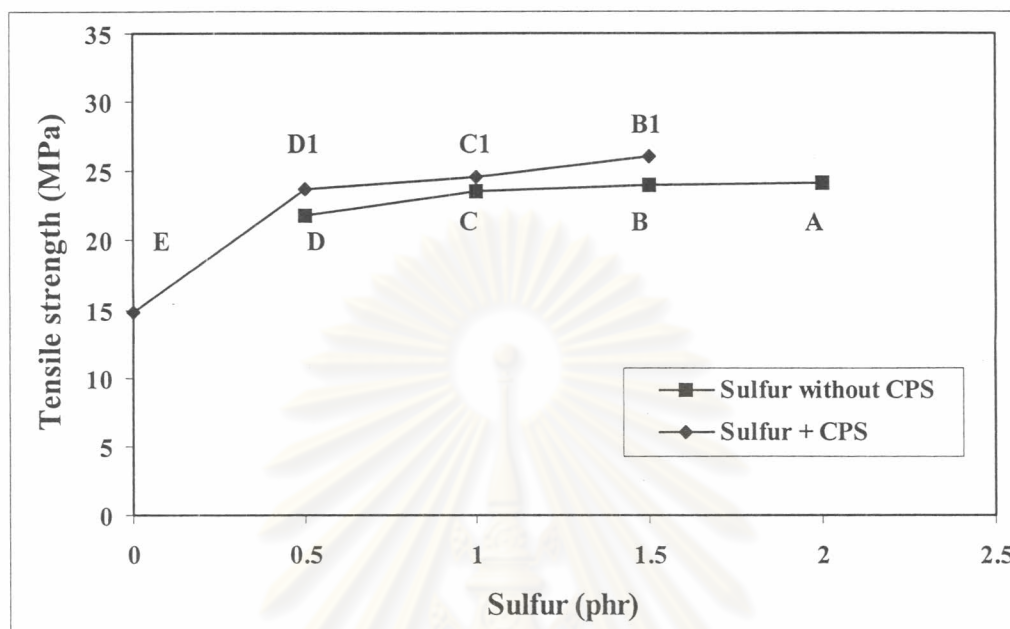

Figure 4.8 Tensile strength of compounds A-D, and B1-E of rubber containing various concentrations of CPS and elemental sulfur of 0 to 2 phr.

From Figure 4.9, elongation of rubbers containing CPS is higher than that of rubbers without CPS. This is because atom of CPS containing cardanol can crosslink with the molecules of rubber, leading to high mobility of molecular chains resulting in high elongation.

ศูนย์วิทยทรัพยากร
จุฬาลงกรณ์มหาวิทยาลัย

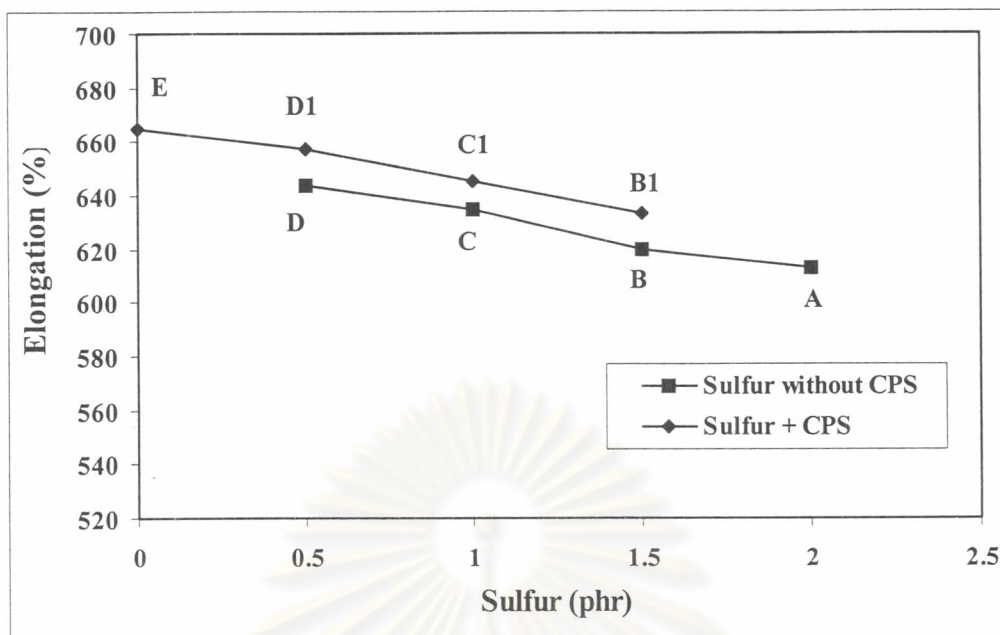

Figure 4.9 Elongation at break of compounds A-D, and B1-E of rubber containing various concentrations of CPS and elemental sulfur of 0 to 2 phr.

From Figure 4.10, the modulus 500% had the same trend. The reason for these observed effects of rubbers containing CPS is the CPS consists of cardanol that can crosslink with the molecules of rubber, leading to high mobility of molecular chains. Hence the modulus is not raised even the degree of crosslinking increases.

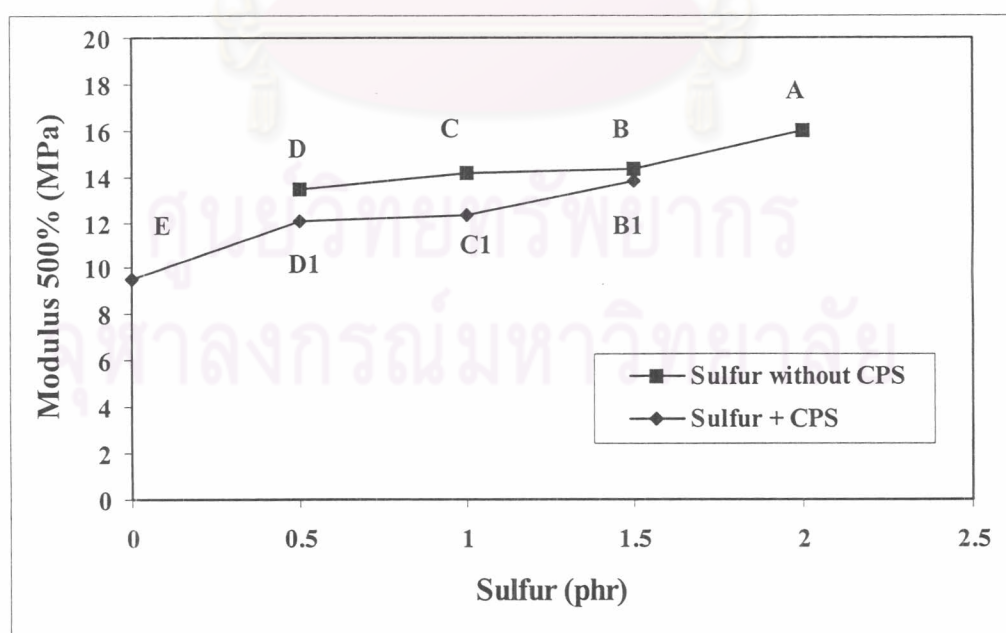

Figure 4.10 Modulus 500% of compounds A-D, and B1-E of rubber containing various concentrations of CPS and elemental sulfur of 0 to 2 phr.

4.4.1.2 Hardness (Shore-A)

The hardness of rubber compounds is shown in Figure 4.11. It can be seen that the hardness of rubbers containing CPS are higher than that of rubbers without CPS. This indicated that CPS could be used as a vulcanizing agent to crosslink with the molecules of rubber, also increasing the degree of crosslinking. As the degree of crosslinking increases, the hardness progressively increases.

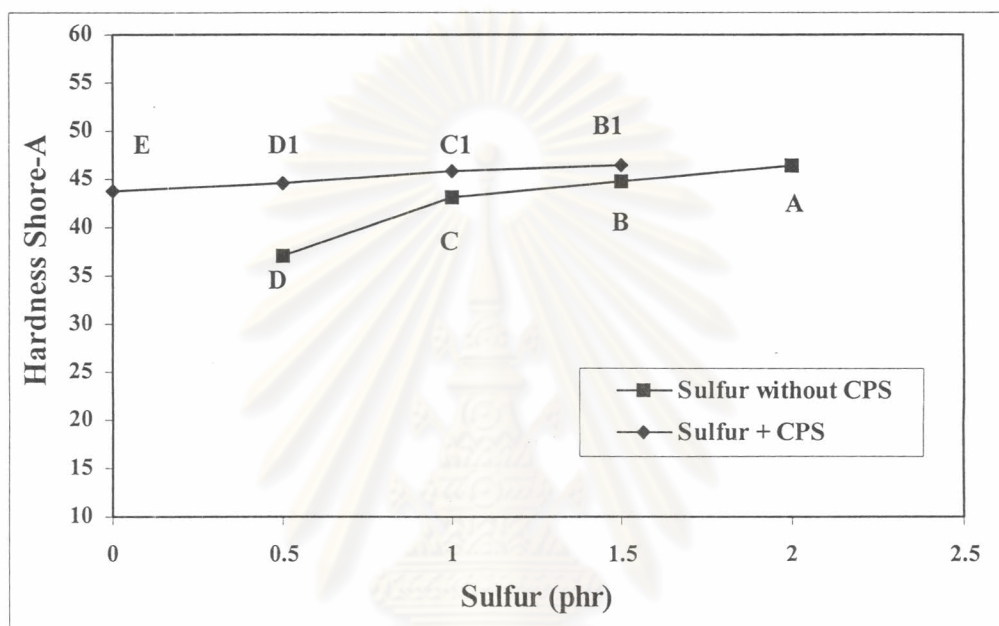

Figure 4.11 Hardness of compounds A-D, and B1-E of rubber containing various concentrations of CPS and elemental sulfur of 0 to 2 phr.

4.4.1.3 Rebound Resilience

The effect of CPS components on rebound resilience of rubber compounds is presented in Figure 4.12. Analysis of rebound resilience revealed that incorporation of large amounts of CPS resulted in the improvement of rebound resilience, but it decreased when the amount of CPS increased. The trend of rebound resilience is not dependent on the degree of crosslinking. This phenomenon can be explained as Figure in 4.13.

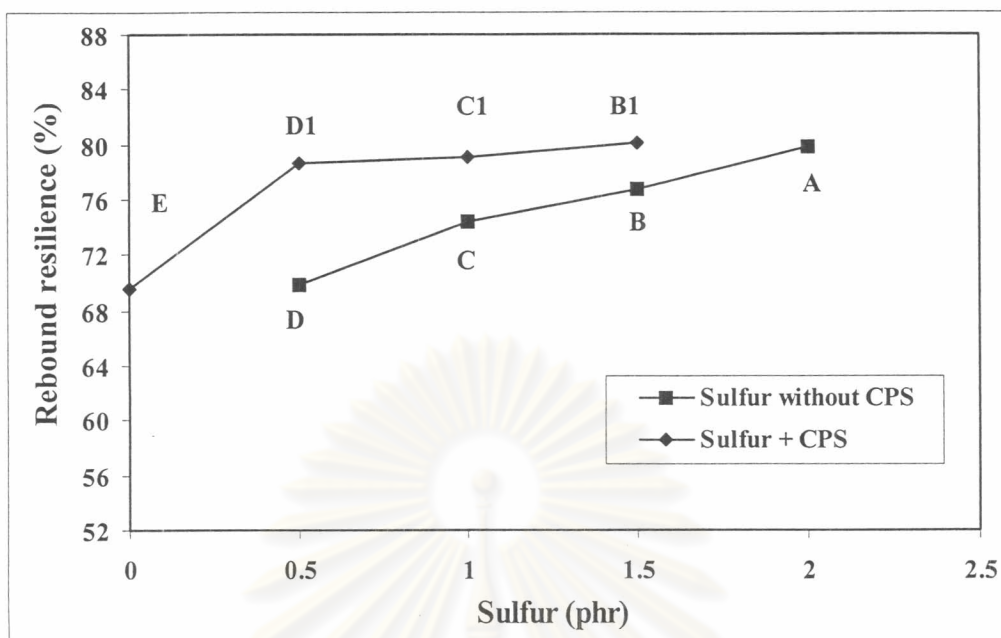

Figure 4.12 Rebound resilience of compounds A-D, and B1-E of rubber containing various concentrations of CPS and elemental sulfur of 0 to 2 phr.

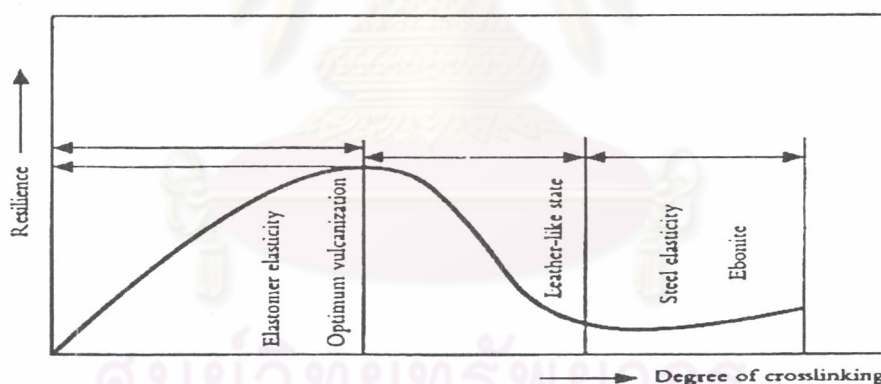

Figure 4.13 Relationship between rebound resilience and degree of crosslinking.

Reproduced from [19]

Based on the degree of crosslinking, rubber elasticity is affected by the crosslink structure. Figure 4.13 illustrates that elasticity increases with increased crosslinking, raising the rebound resilience to an optimum value. As the number of crosslinks increase, the molecules or their segments become so firmly attached to one another that their tendency to return to the basic position after deformation cases, i.e. the elastomers elasticity, becomes more pronounced.

4.4.2 Mechanical Properties of Series B

The effect of CPS content in rubber compounds on the mechanical properties was investigated when the amount of sulfur was kept constant at 1.5 phr.

4.4.2.1 Tensile Properties

The effect of CPS content on tensile properties of rubber compounds of series B is shown in Figures 4.14, 4.15 and 4.16.

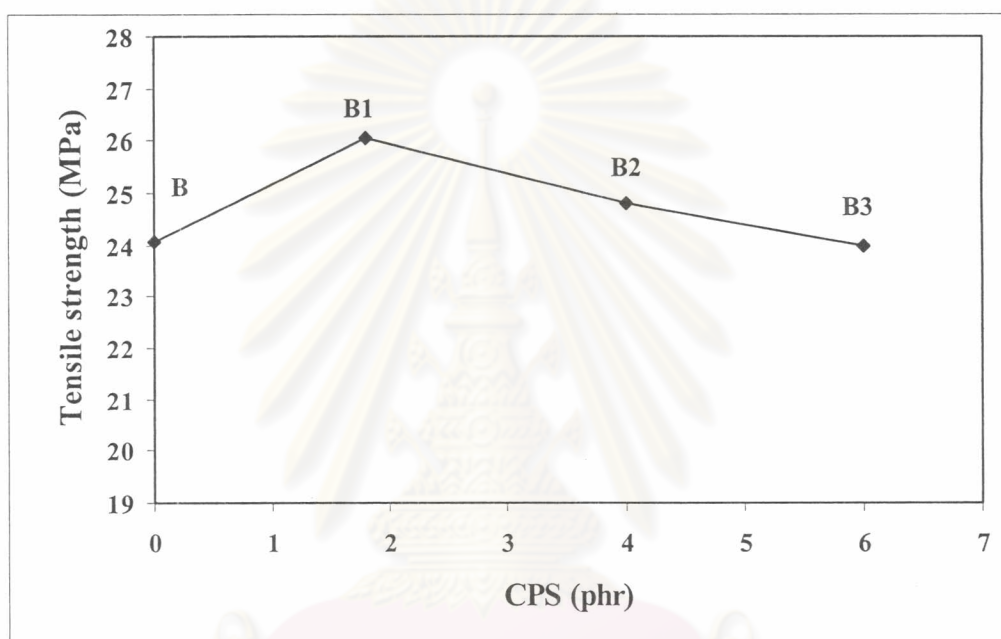

Figure 4.14 Tensile strength of series B of rubbers containing various concentrations of CPS and elemental sulfur of 1.5 phr.

From Figure 4.14, the rubber containing CPS of 2 phr has tensile strength higher than the rubber without CPS. Addition of CPS greater than 2 phr into the rubber resulted in a decrease in tensile strength of the rubber. This may be explained using Figure 4.15 [14]. Tensile strength rises with the number of crosslinks until an optimum is reached, after which, if the crosslinking is continued (in which case over-crosslinking takes place), it initially falls steeply.

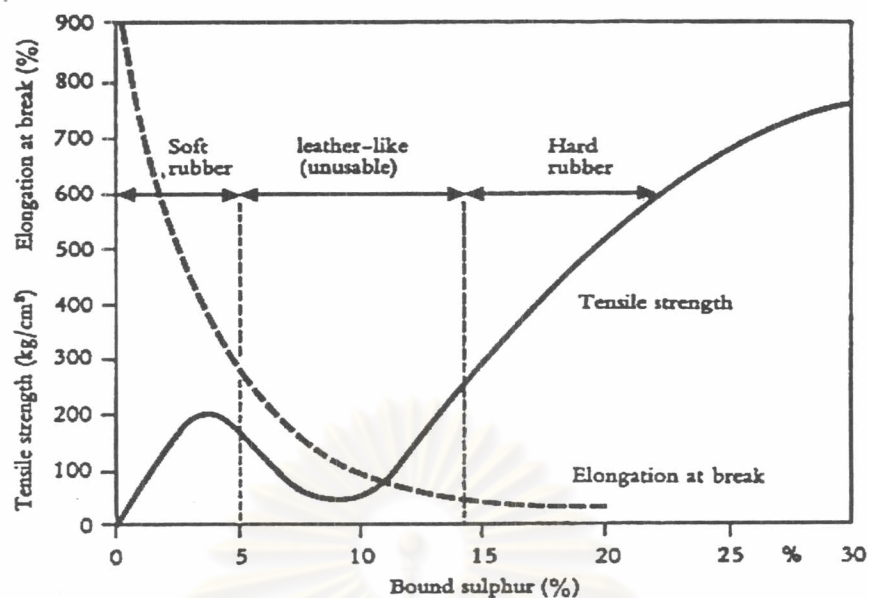

Figure 4.15 Relationship between tensile strength (kg cm^{-2}) and elongation (%) with bound sulfur (%). Reproduced from [14].

From Figure 4.16, the elongation of the rubber was improved with increasing the amount of CPS. This can be elucidated as previously mentioned in Section 4.4.1.1 that when the proportion of CPS increases, the network obtained from cardanol results in high mobility of molecular chains.

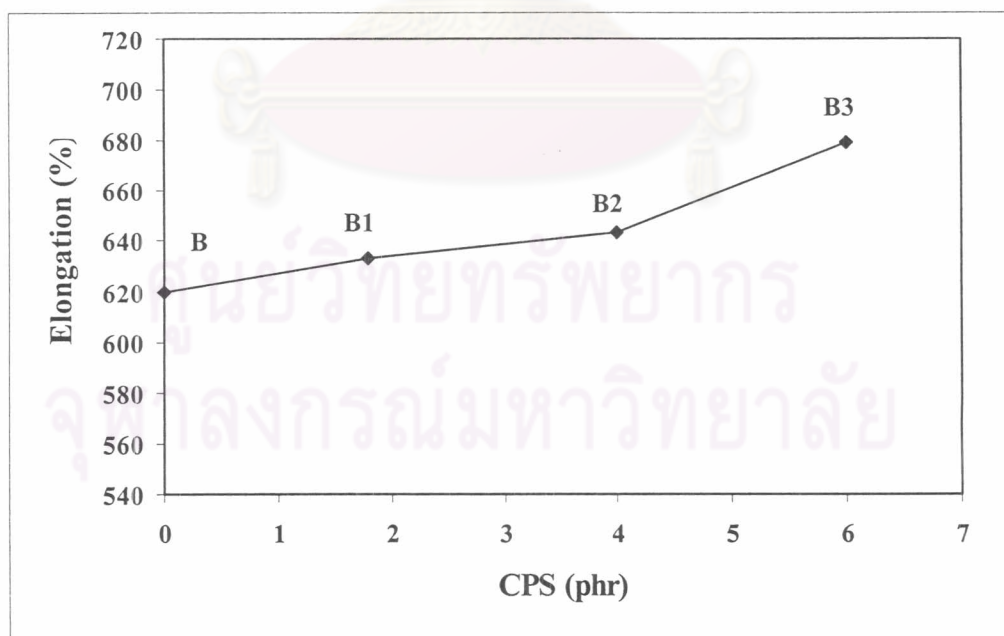

Figure 4.16 Elongation at break of series B of rubbers containing various concentrations of CPS and elemental sulfur of 1.5 phr.

The definite modulus or definite degree of crosslinking is related to the length of the crosslinking. From Figure 4.17, the modulus of rubber decreased with increasing CPS in the rubber. This is because CPS can liberate sulfide and crosslink with the molecules of rubber. The network structures of CPS are obtained from cardanol, which has a long chain of alkyl phenol. Thus it may be expected that the network structures consist of long bridge links, having free mobility of chain segments, leading to low modulus. On the other hand, if the network is obtained from only sulfur atom, the distance between the chains is not so long, thus the modulus is high. The longer the chain, the lower the modulus value.

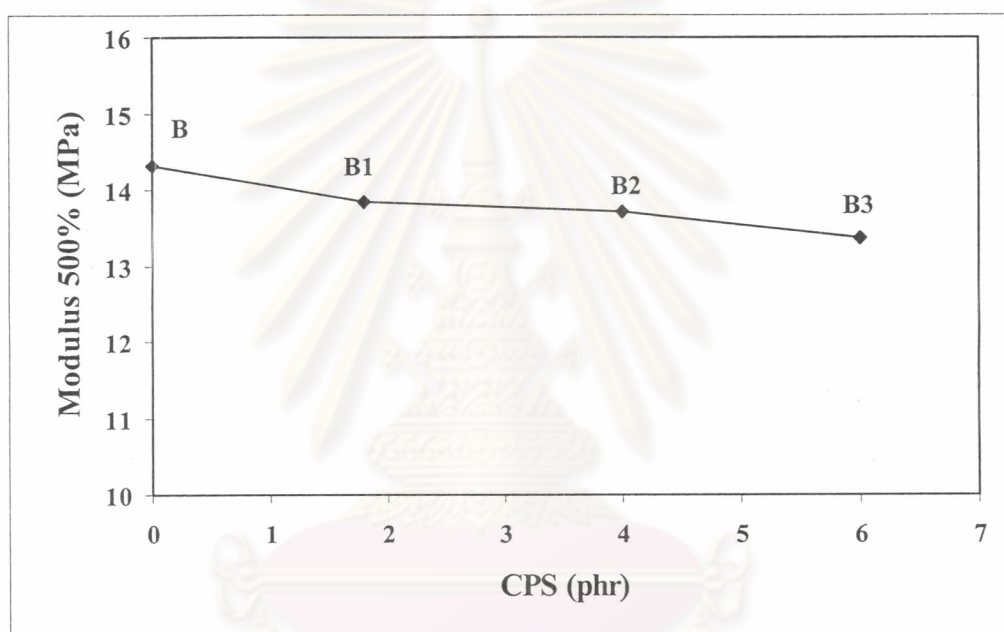

Figure 4.17 Modulus 500% of series B of rubbers containing various concentrations of CPS and elemental sulfur of 1.5 phr.

4.4.2.2 Hardness (Shore-A)

Figure 4.18 shows the hardness of rubber compounds of series B. The hardness of the rubber compounds improved when the CPS content increased. This is due to the fact that the high degree of crosslink of the rubber gives the high values of hardness of the rubber.

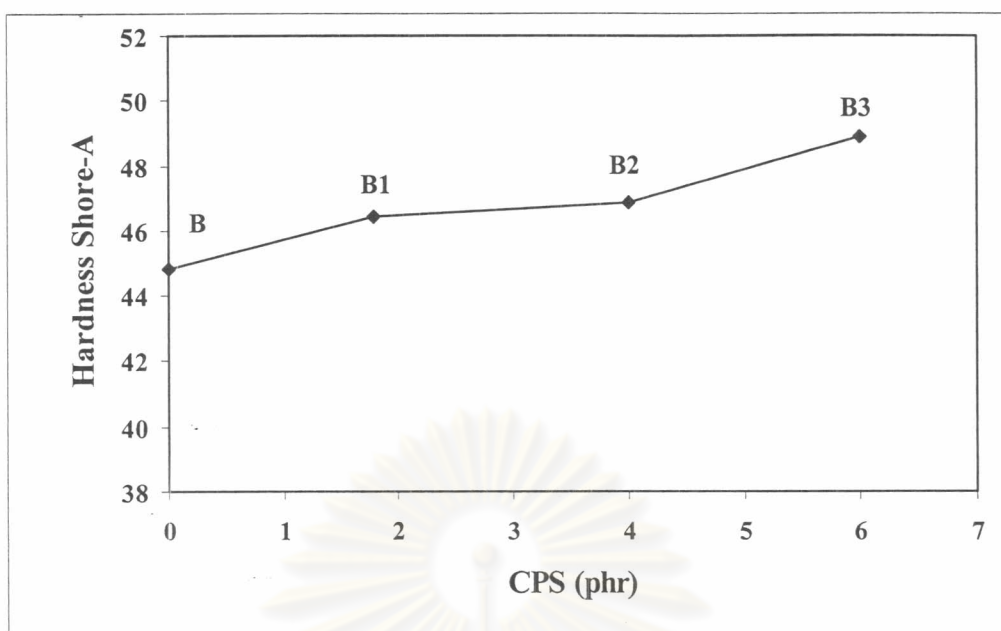

Figure 4.18 Hardness of series B of rubbers containing various concentrations of CPS and elemental sulfur of 1.5 phr.

4.4.2.3 Rebound Resilience

The effect of CPS content on rebound resilience in rubber compounds of series B is revealed in Figure 4.19. The rebound resilience of rubber compounds were improved when the CPS content increased. The result shows that the degree of crosslinking increased by CPS, thus the rebound resilience improved due to higher degree of crosslinking.

ศูนย์วิทยทรัพยากร
จุฬาลงกรณ์มหาวิทยาลัย

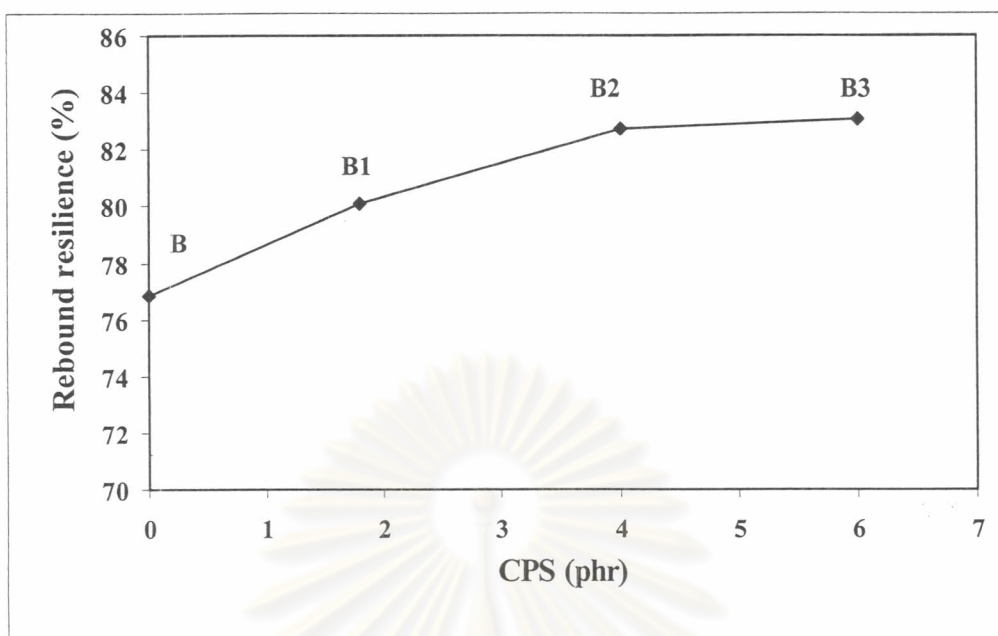

Figure 4.19 Rebound resilience of series B of rubbers containing various concentrations of CPS and elemental sulfur of 1.5 phr.

4.4.3 Mechanical Properties of Rubber Compounds in Series E

The effects of CPS content in rubber compounds of series E on mechanical properties were observed.

4.4.3.1 Tensile Properties

The effects of CPS content on tensile properties of rubber compounds in series E are shown in Figures 4.20, 4.21 and 4.22.

From Figure 4.20, the tensile strength of the rubber was increase when the CPS content increase. This is due to an increase of the degree of crosslinking of the rubber.

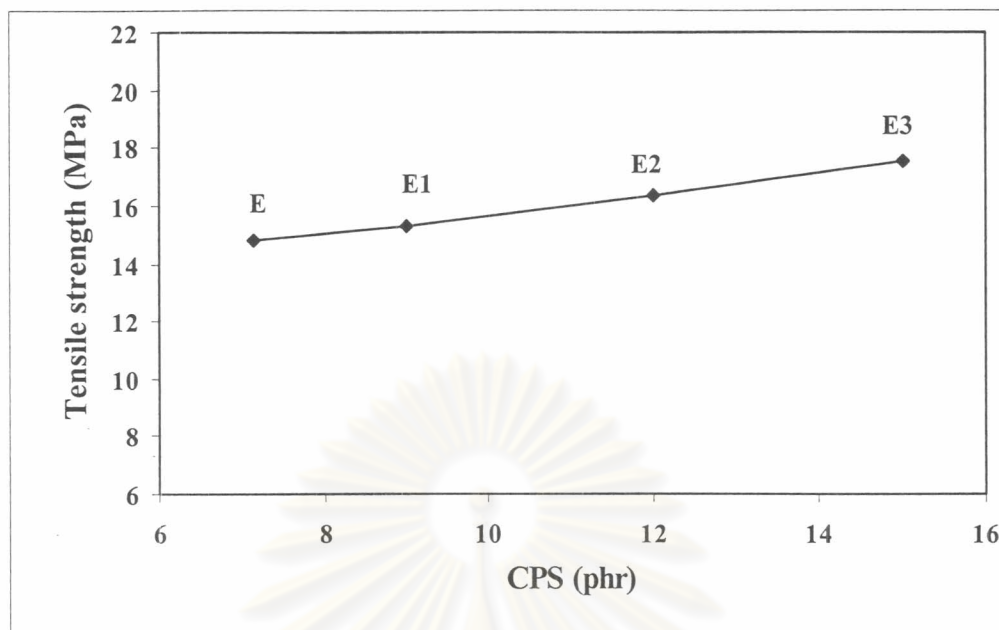

Figure 4.20 Tensile strength of series E of rubbers containing various concentrations of CPS of 7.14 to 15 phr.

From Figure 4.21, the elongation of the rubber compounds increased when the amount of CPS increased. The reason of an increase in the elongation due to CPS is mentioned in Section 4.4.2.1.

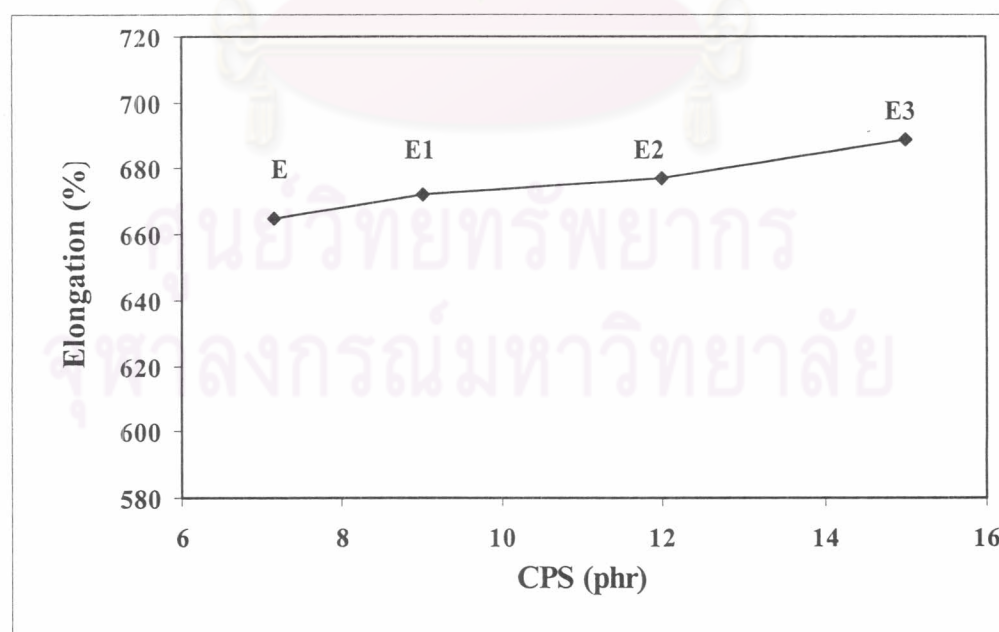

Figure 4.21 Elongation at break of series E of rubbers containing various concentrations of CPS of 7.14 to 15 phr.

From Figure 4.22, the modulus of rubber compounds of series E was increased. This is because rubber compounds in series E are the rubbers containing only CPS, hence, the distances of chain segments of each compound are near. Thus, the modulus was independent of the degree of crosslinking.

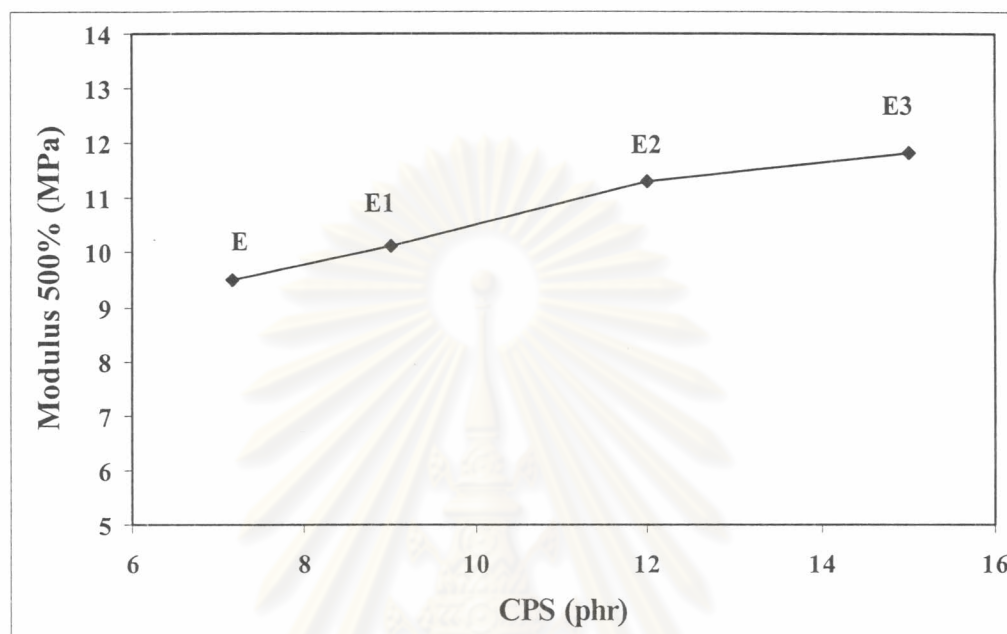

Figure 4.22 Modulus 500% of series E of rubbers containing various concentrations of CPS of 7.14 to 15 phr.

4.4.3.2 Hardness (Shore-A)

From Figure 4.32, the hardness of rubber compounds of series E was improved when the CPS content increased. This is indicated that the hardness increased following the degree of crosslinking.

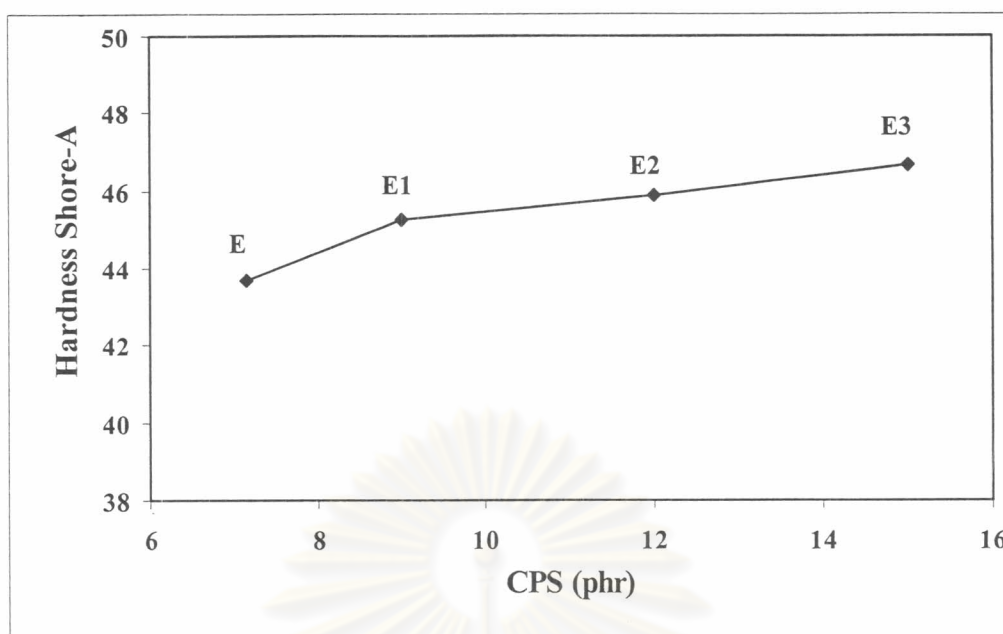

Figure 4.23 Hardness of series E of rubbers containing various concentrations of CPS of 7.14 to 15 phr.

4.4.3.3 Rebound Resilience

From Figure 4.24, the rebound resilience of rubber compounds of series E was improved when the CPS content increased. This indicates that the rising of rebound resilience was based upon the degree of crosslink. The result of this experiment is quite similar to Figure 4.19, which shows the increasing rebound resilience of series B.

ศูนย์วิทยทรัพยากร
จุฬาลงกรณ์มหาวิทยาลัย

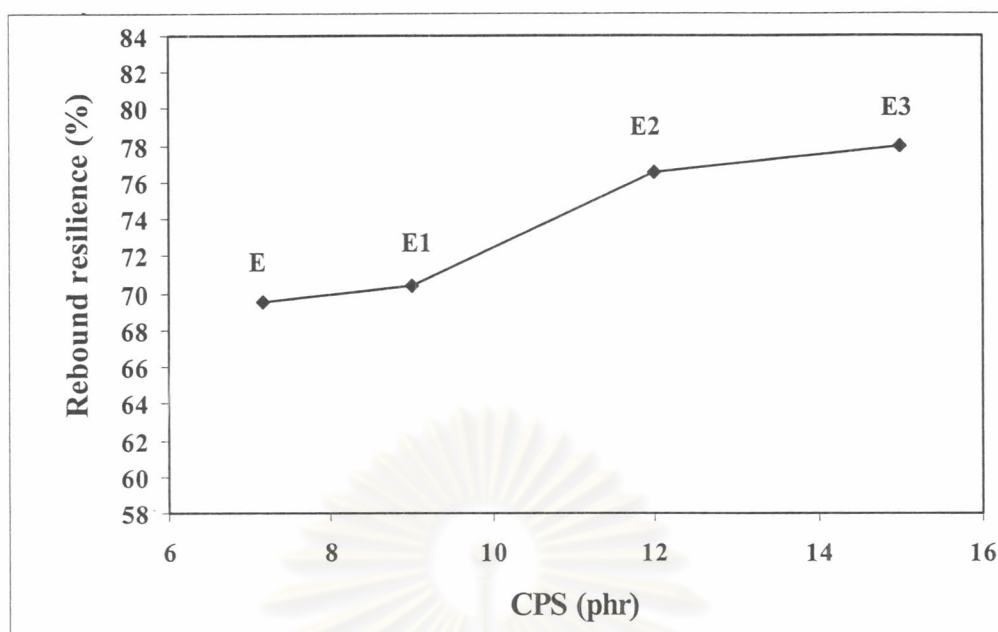

Figure 4.24 Rebound resilience of series E of rubbers containing various concentrations of CPS of 7.14 to 15 phr.

4.5 Effect of CPS on Accelerated Aging Test of Rubber Compounds

The difference in ultimate elongation before and after heating is the most useful criterion for judging the durability of vulcanized rubbers. The ultimate elongation of practically all vulcanized rubbers decreases during aging; the rate of decrease depends on temperature, time, and composition of yellow rubbers. In this research, the specimens were placed in an oven at 100°C for 1 or 3 days, then the mechanical properties aged specimens were investigated and shown in Appendix E. The percentage changes in mechanical properties i.e., tensile strength, elongation, modulus 500% and hardness or % reversion (compared to unaged specimens) were calculated using equations as shown in Appendix E. The data of % reversion of each of the mechanical properties are shown in Table 4.4.

Table 4.4 % Reversion of rubber compounds

% reversion	Tensile Strength (MPa)		Elongation at break (%)		Modulus 500% (MPa)		Hardness (Shore-A)	
	1 day	3 days	1 day	3 days	1 day	3 days	1 day	3 days
A	-34.98	-62.99	-30.32	-56.47	-	-	2.30	2.50
B	-29.41	-56.62	-23.87	-51.50	-	-	1.25	2.30
B1	-22.34	-46.11	-23.37	-50.78	-	-	1.30	2.50
B2	-14.45	-36.96	-19.51	-41.00	15.02	-	1.90	3.00
B3	-11.07	-34.57	-19.02	-40.33	16.41	-	2.40	3.00
C	-28.61	-40.41	-16.70	-45.03	10.79	-	1.45	2.00
C1	-18.87	-28.63	-15.79	-34.57	15.39	-	2.20	2.30
D	-20.95	-31.62	-14.68	-41.42	14.10	-	1.35	2.10
D1	-20.22	-26.04	-14.66	-22.50	16.24	19.85	2.55	2.60
E	-19.82	-24.39	-13.77	-17.61	18.12	21.66	2.55	2.75
E1	-15.55	-18.13	-12.77	-16.61	18.53	23.59	2.60	2.80
E2	-11.98	-17.02	-10.74	-16.64	19.13	27.67	2.50	2.80
E3	-8.64	-17.54	-9.38	-15.95	19.75	28.73	3.00	3.20

- cannot determine

4.5.1 Effect of CPS on Accelerated Aging Test of Compounds A-E

The effect of CPS on accelerated aging of compounds A-E was studied. The results of rubbers containing CPS were compared to rubbers without CPS. All data of aged species are shown in Appendix E.

4.5.1.1 Reversion of Tensile Properties

From Table 4.4, Figures 4.25, 4.26 and 4.27, all % reversion of the tensile properties, i.e. tensile strength, elongation at break and modulus 500% show that rubbers containing CPS have lower reversion than rubbers without CPS. It can be explained that CPS may have mono-, di- or polysulfide linkages, which is a stronger bond than polysulfide from elemental sulfur. Besides, CPS may crosslink with the molecules of rubber by carbon-carbon bond from unsaturated alkyl chains of

cardanol. When the bond energy is high, the compounds will have good heat stability (see Table 4.5). This indicates that CPS has anti-reversion properties.

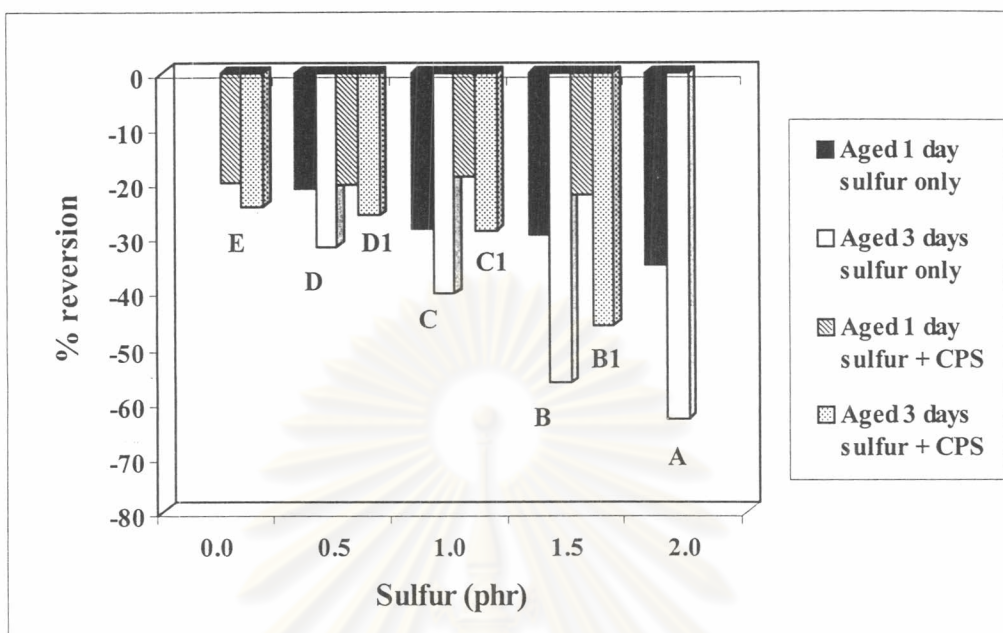

Figure 4.25 % reversion of tensile strength of compounds A-D, and B1-E of rubber containing various concentrations of CPS and elemental sulfur of 0 to 2 phr.

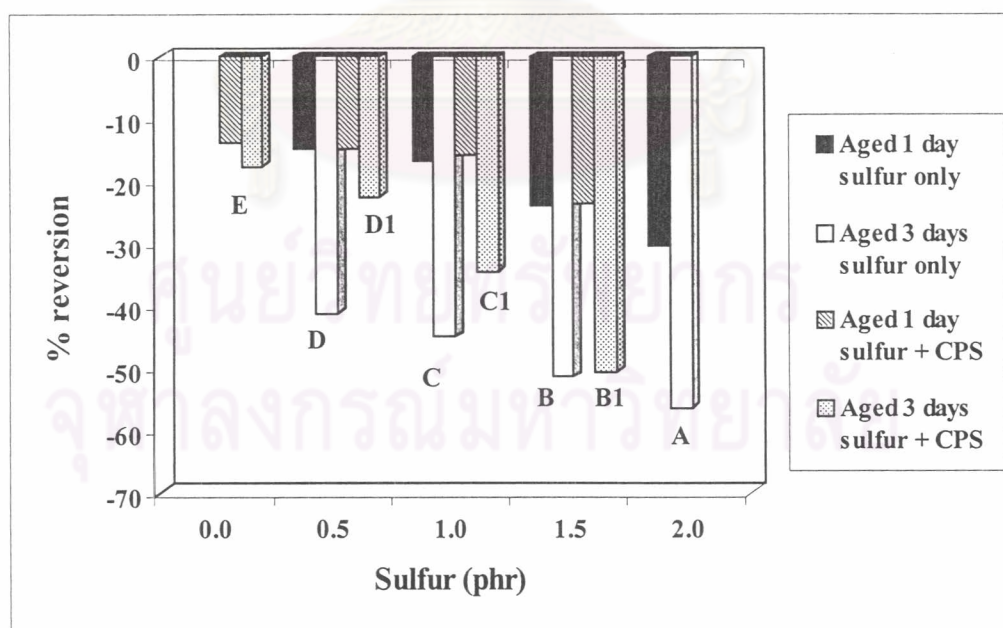

Figure 4.26 % reversion of elongation at break of compounds A-D, and B1-E of rubber containing various concentrations of CPS and elemental sulfur of 0 to 2 phr.

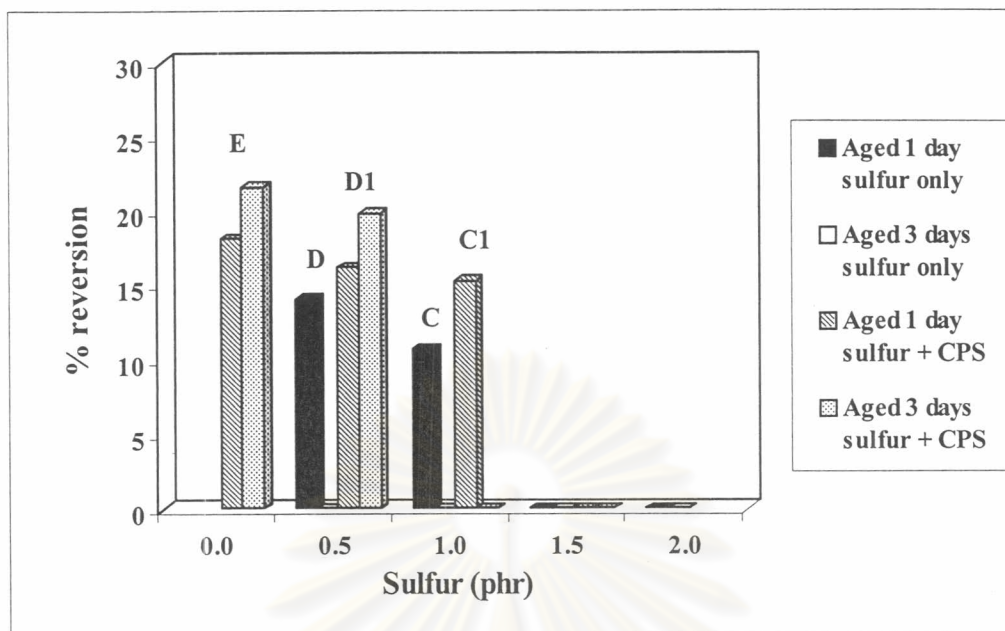

Figure 4.27 % reversion of modulus 500% of compounds A-D, and B1-E of rubber containing various concentrations of CPS and elemental sulfur of 0 to 2 phr.

Table 4.5 Bond energy of various types of crosslink [18].

Types of linkage	Bond energy (kcal/mol)
-C-S _x -C-	<64
-C-S-S-C-	64
-C-S-C-	68
-C-C-	84

4.5.1.2 Reversion of Hardness

From Figures 4.27 and 4.28, the values of modulus and hardness of rubber compounds were accelerated aging or prolonged storage at room temperature. It can be explained that the postvulcanization which takes place from the accelerated aging test (or prolonged storing at room temperature) is due not only to the incorporation of additional free sulfur after the vulcanization, but also some extent, as seen in Scheme 4.2 [18], to the shortening of the polythioether bridges and the simultaneous formation of additional crosslinks. In this reaction, a S_x bridge is of course split before

being re-established after its shortening. In this splitting of the sulfur chains, which are incorporated as bridge links, the renewed crosslinking also takes place similarly to crosslinking processes. Accelerators, which are able to activate free sulfur, are at any rate also capable as far as they survive the vulcanization process without being decomposed of activating and splitting crosslinked polythio chains, leading to the hardness is rising after accelerated aging. Moreover, % reversion of hardness of rubbers containing CPS is higher than rubbers without CPS. This confirms the anti-reversion properties of CPS.

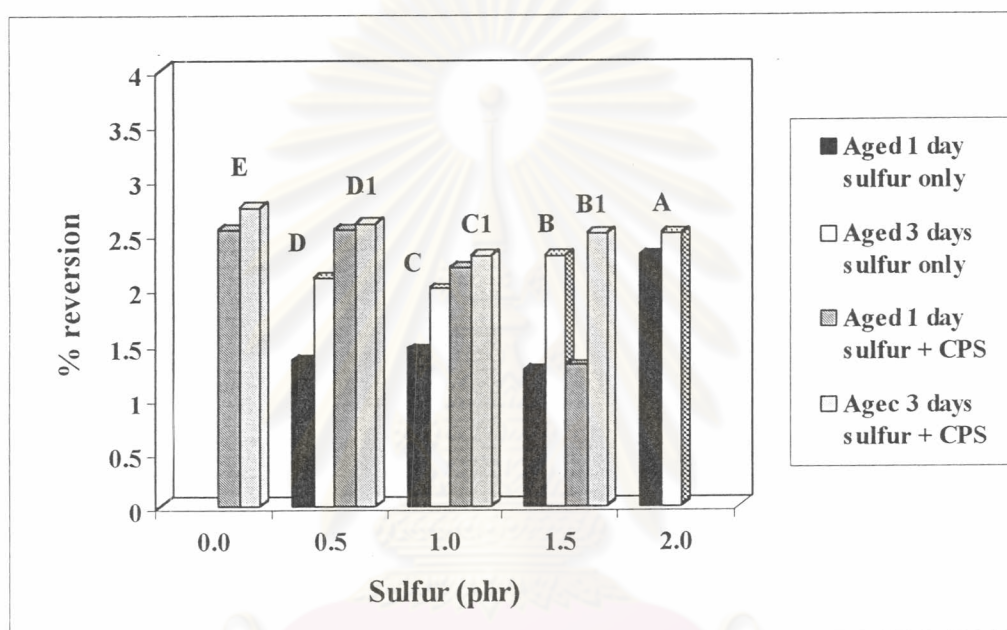
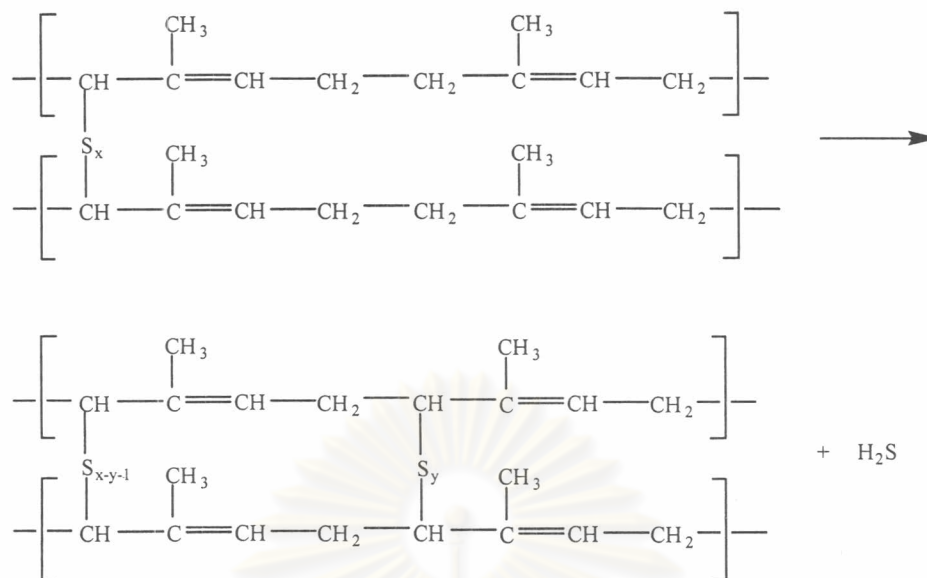

Figure 4.28 % reversion of hardness of compounds A-D, and B1-E of rubber containing various concentrations of CPS and elemental sulfur of 0 to 2 phr.

ศูนย์วิทยทรัพยากร
จุฬาลงกรณ์มหาวิทยาลัย



Scheme 4.2 Splitting of sulfur bond after vulcanization. Adapted from [18].

4.5.2 Effect of CPS Content on Accelerated Aging Test of Rubber

Compounds Containing Elemental Sulfur of 1.5 phr (series B)

The effects of CPS on accelerated aging test of rubber compound of series B were investigated. All data of aged species are shown in Appendix E.

4.5.2.1 Reversion of Tensile Properties

From Figures 4.29 and 4.30, it can be seen that % reversion of tensile strength and elongation of rubber compound of series B decreases with an increase in CPS. From Figure 4.31, at 0 and 1.79 phr of CPS in rubber, the modulus values could not be measured, therefore %reversion were not obtained.

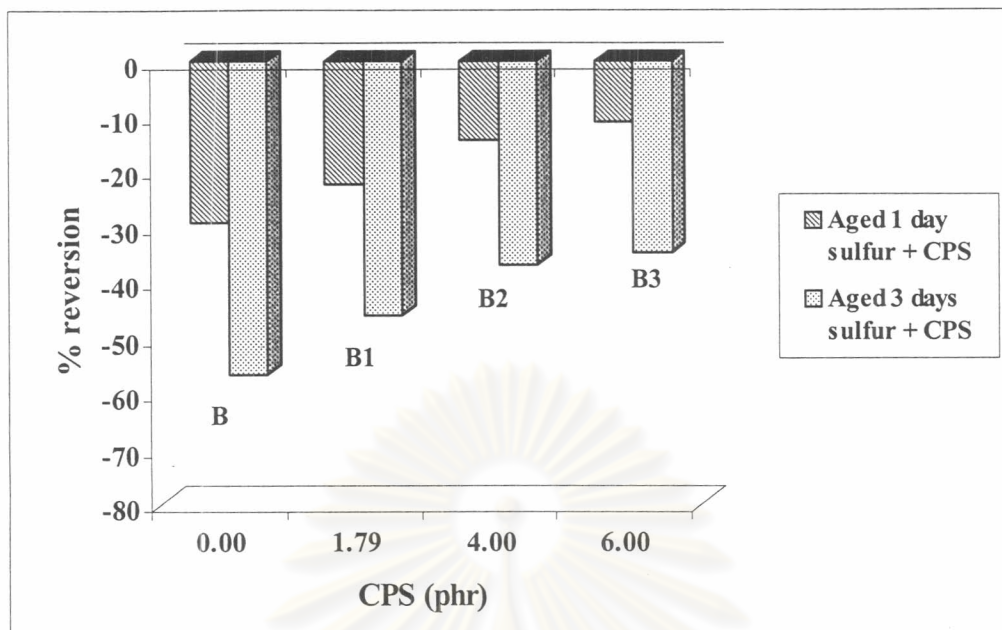

Figure 4.29 % reversion of tensile strength of series B of rubbers containing various concentrations of CPS and elemental sulfur of 1.5 phr.

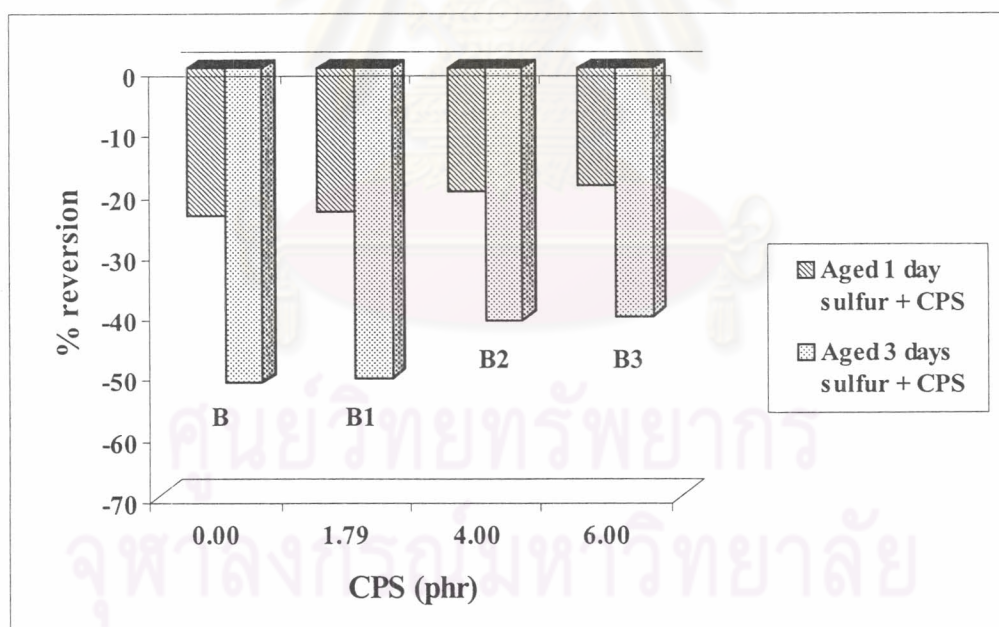

Figure 4.30 % reversion of elongation at break of series B of rubbers containing various concentrations of CPS and elemental sulfur of 1.5 phr.

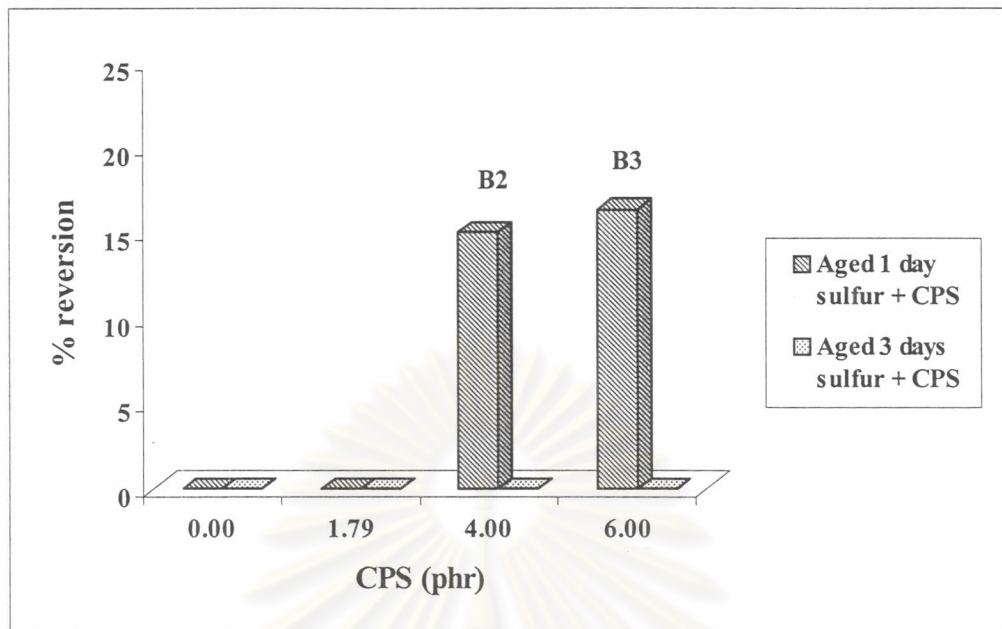

Figure 4.31 % reversion of modulus 500% of series B of rubbers containing various concentrations of CPS and elemental sulfur of 1.5 phr.

4.5.2.2 Reversion of Hardness

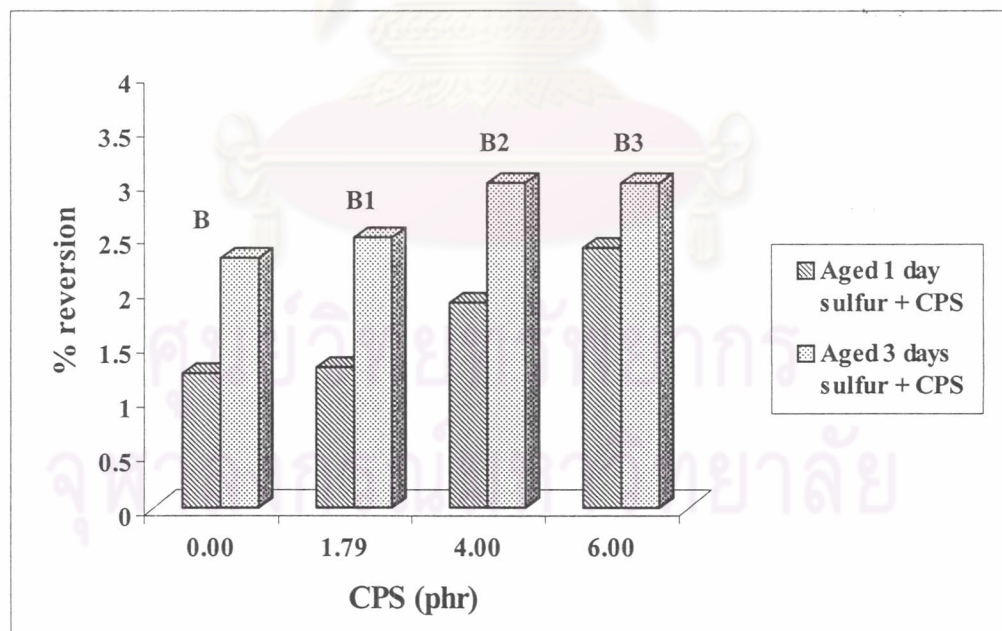

Figure 4.32 % reversion of hardness of series B of rubbers containing various concentrations of CPS and elemental sulfur of 1.5 phr.

From Figure 4.32 and Section 4.4.2, the results show the nearly improve of hardness after aging even as the degree of crosslinking increases. This indicates that CPS can reduce the reversion of rubber compounds.

4.5.3 Effect of CPS Content on Accelerated Aging Test of Rubber Compounds without Sulfur (series E)

The effects of CPS on accelerated aging test of rubber compounds of series E were observed. The details of all data of aged species are shown in Appendix E.

4.5.3.1 Reversion of Tensile Properties

From Figures 4.33, 4.34 and 4.35, it can be seen that rubber compounds of series E have low % reversion of most of the mechanical properties. The reason of this is that the sulfur linkage is split and re-established again after aging, as shown from Scheme 4.2. This also indicates that CPS can reduce the reversion.

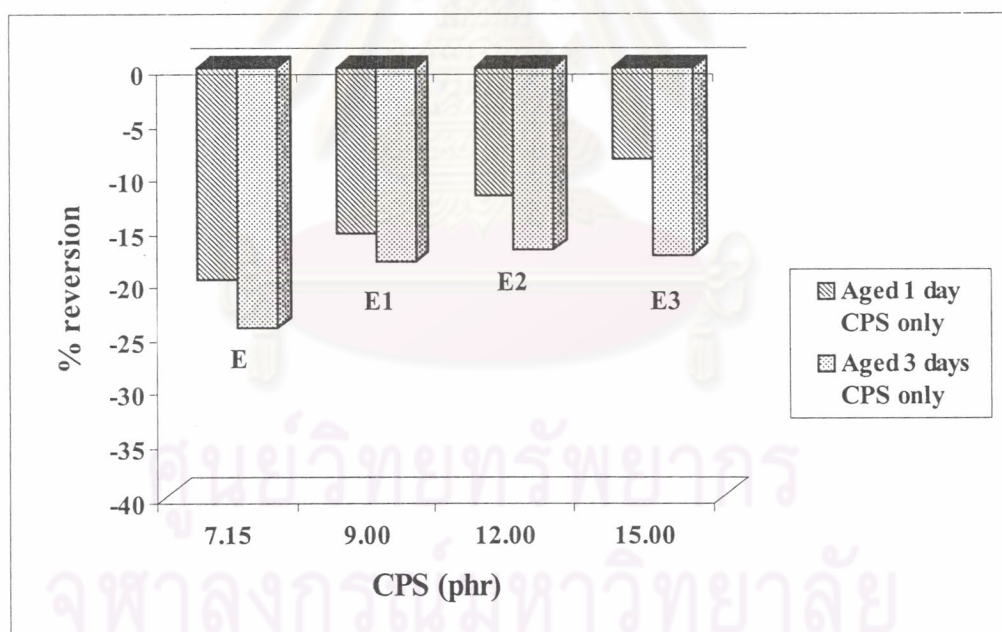

Figure 4.33 % reversion of tensile strength of series E of rubbers containing various concentrations of CPS of 7.14 to 15 phr.

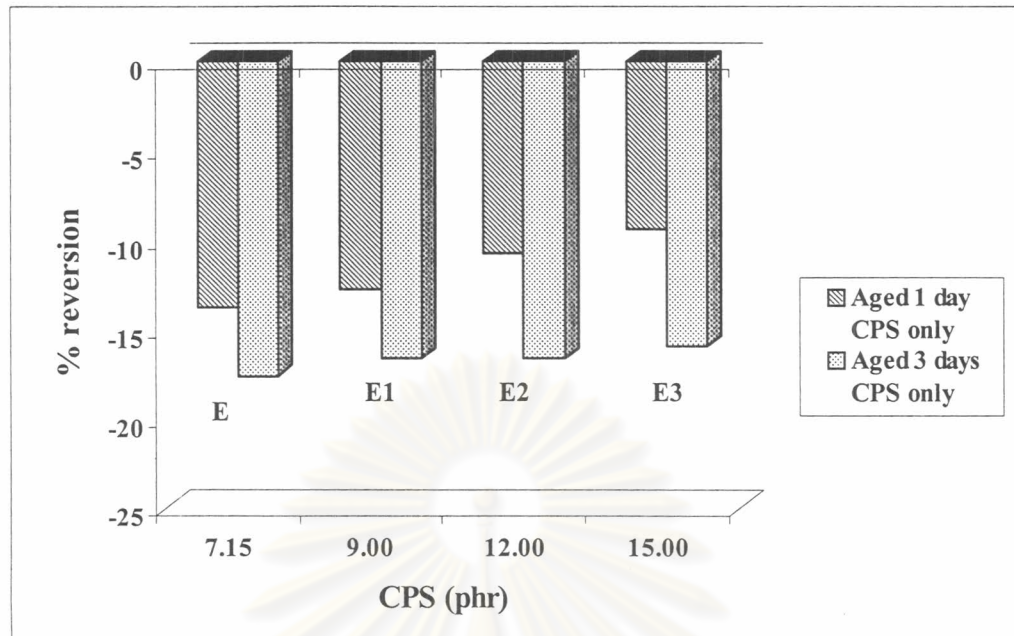

Figure 4.34 % reversion of elongation at break of series E of rubbers containing various concentrations of CPS of 7.14 to 15 phr.

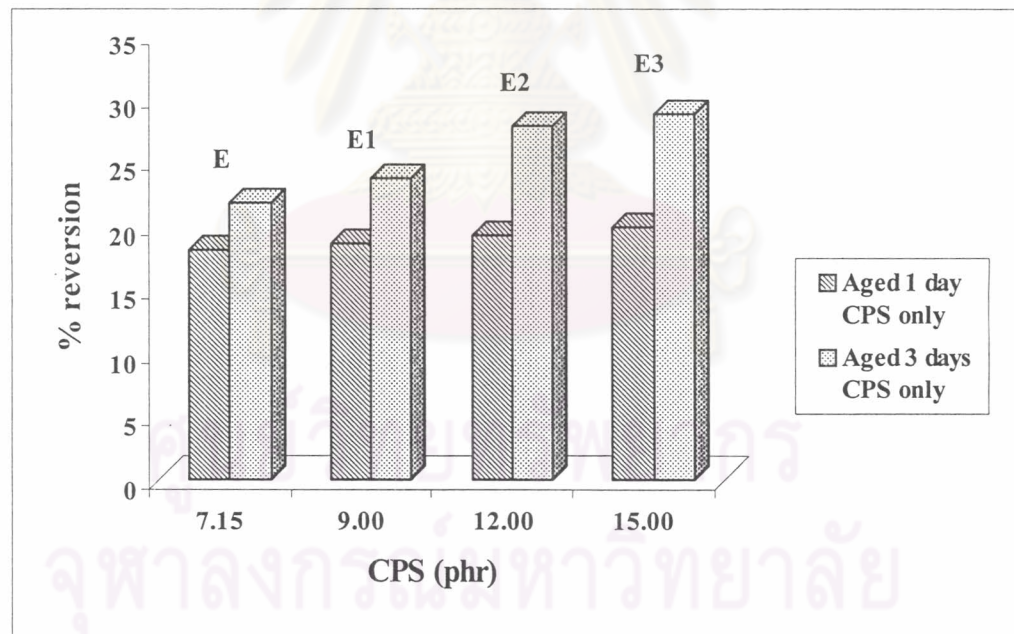

Figure 4.35 % reversion of modulus 500% of series E of rubbers containing various concentrations of CPS of 7.14 to 15 phr.

4.5.3.2 Reversion of Hardness

From Figure 4.36, the hardness of rubber compounds of series E was improved after aging. This supports Sections 4.4.2.2 and 4.4.3.2 with the same reason and this confirms that CPS can reduce the reversion of rubber compounds.

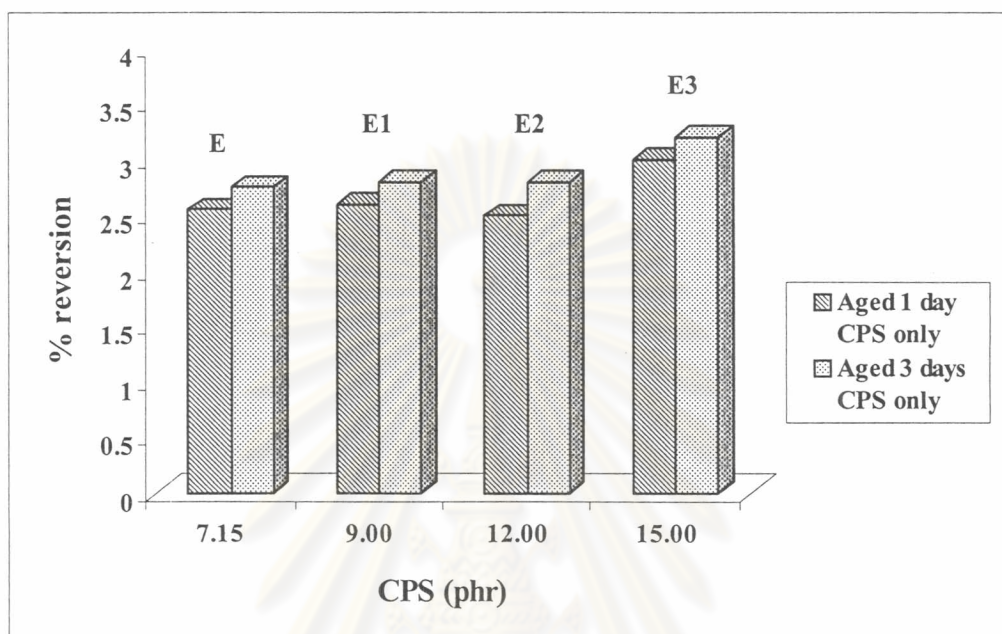

Figure 4.36 % reversion of hardness (Shore-A) of series E of rubbers containing various concentrations of CPS of 7.14 to 15 phr.

4.6 A Comparison of Properties of Rubber Compounds Containing CPS Obtained from Previous and This Research

4.6.1 Comparison with Radeemada's Work

Radeemada's work used the decarboxylated CNSL containing cardanol and other compounds for preparation of vulcanizing agent, while pure cardanol separated from the decarboxylated CNSL was used in this work.

The amount of cardanol in decarboxylated CNSL used in her work was not reported. In this work, 80% wt/wt cardanol separated from decarboxylated CNSL was found. Thus, vulcanizing agent used in this work is pure CPS, while that in Radeemada's work is expected to be a mixture of 80% CPS and 20% other compounds.

Table 4.6 shows a comparison of ingredients in non-productive compound of this work and Radeemada's work, and Table 4.7 shows a comparison of ingredients in productive compounds of this work and Radeemada's work.

Table 4.6 Comparison of ingredients in non-productive compound

Ingredients	Quantity (phr)	
	Radeemada's work	This work
NR STR20	100	100
Peptizer	0.07	-
Resorcinol	1.1	1.1
Aromatic oil	3.5	-
Naphthenic oil	-	3.5
Carbon black	24	24
Stearic acid	2	2
ZnO	3	3

Table 4.7 Comparison of ingredients in productive compounds

Compounds	Vulcanization ingredients (phr)					
	Radeemada's work			This work		
	CBS	sulfur	Impure CPS	CBS	sulfur	Pure CPS
A	1.5	2.0	-	1.5	2.0	-
B	1.5	1.5	-	1.5	1.5	-
B1	1.5	1.5	1.67	1.5	1.5	1.79
B2	1.5	1.5	4.0	1.5	1.5	4.0
B3	1.5	1.5	6.0	1.5	1.5	6.0
C	1.5	1.0	-	1.5	1.0	-
C1	1.5	1.0	3.33	1.5	1.0	3.57
D	1.5	0.5	-	1.5	0.5	-
D1	1.5	0.5	5.0	1.5	0.5	5.36
E	1.5	-	6.67	1.5	-	7.14
E1	1.5	-	9.0	1.5	-	9.0
E2	1.5	-	12.0	1.5	-	12.0
E3	1.5	-	15.0	1.5	-	15.0

4.6.1.1 Comparison of Vulcanization Characteristics.

The results were compared between Radeemada's work and this work when CPS were used equivalent quantity.

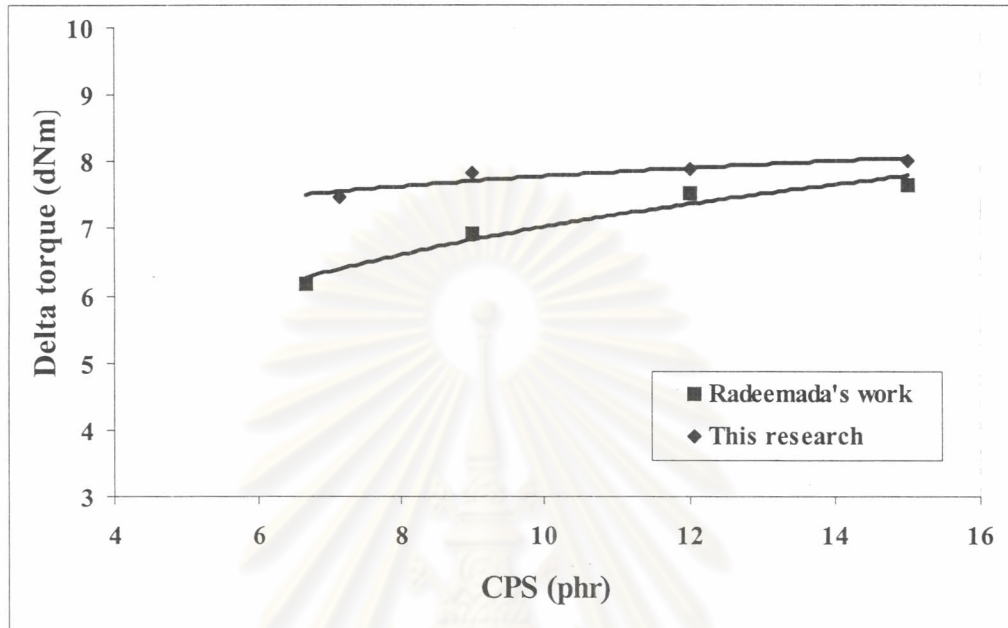

Figure 4.37 Delta torque of rubber compounds of Radeemada's work [25] and this work.

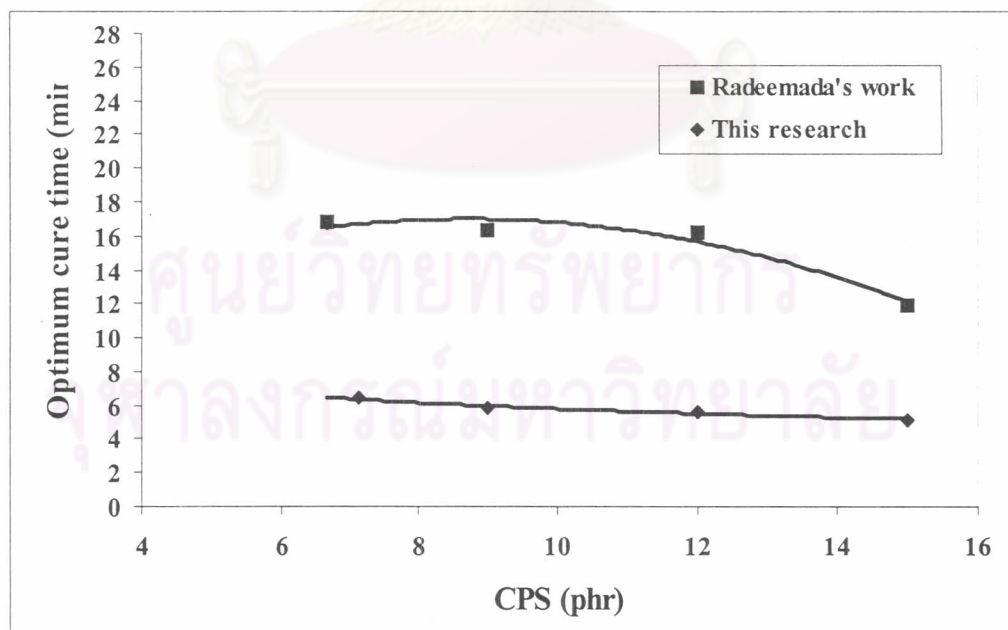

Figure 4.38 Optimum cure time of rubber compounds of Radeemada's work [25] and this work.

From Figure 4.37, at each amount of vulcanizing agent the delta torque of rubber compounds in this work, was found to be higher than that in Radeemada's work. This may be because pure CPS used in this work can liberate sulfur to crosslink with the molecules of rubber better than impure CPS in Radeemada's work. Consequently, the delta torque of rubber compounds in this work was higher than that in Radeemada's work. From Figure 4.38, the optimum cure time of rubber compounds in this work was found to be lower than that in Radeemada's work. This may be because pure CPS used in this work occurred rapid onset of vulcanization than impure CPS used in Radeemada's work.

4.6.2 Comparison with Rabindra's Work

Rabindra used alkyl phenol disulfide (Vultac[®] 710) as vulcanizing agent. A comparison of ingredients and mechanical properties is shown in Tables 4.8 and 4.9, respectively.

Table 4.8 Comparison of ingredients of Rabindra's Work and this work

Ingredients	Quantity (phr)	
	Rabindra's Work	This work
NR SMR CV	100	-
NR STR20	-	100
Carbon black	50	24
ZnO	5	3
Stearic acid	2	2
Aromatic oil	3	-
Naphthenic oil	-	3.5
CBS	1.5	1.5
Sulfur	1.5	1.5
BCI-MX*	0.6	-
Vultac [®] 710**	0.5	-
CPS	-	1.79

* N, N'-m-xylylene-bis-citraconimide

** alkyl phenol disulfide containing 27.4% sulfur

Table 4.9 Comparison of mechanical properties with Rabindra's work

Mechanical properties	Rabindra's Work	This research
Tensile strength (MPa)	28.9	26.04
Elongation (%)	455	633.32
Modulus 500% (MPa)	-*	13.83

* This property was not tested.

From Table 4.8, the amounts of ingredients used in this research, such as carbon black and ZnO, were less than those in Rabindra's work. The rubber compound of this research did not contain BCI-MX which anti-reversion coagent. From Table 4.9, the tensile strength of rubber compounds in this work was slightly lower than that in Rabindra's work. This may be due to carbon black which acts as reinforcing filler. Elongation of rubber compounds in this research was higher than Rabindra's work. This may be attributed to the plasticization effect of CPS.

4.6.3 A Comparison of Properties of Rubber Compounds in This Work with Standard Properties Specified by Thai Industrial Standard Institute (TISI)

Table 4.10 shows a comparison of the properties of rubber compound obtained from this work and those of some rubber products reported in [37-39].

Table 4.10 The properties of rubber compound in this work and standard specification of rubber products

Properties	Automotive rubber mats (5 th quality)	Motorcycle rubber inner tubes	Weather strips for automobile	This research
Tensile strength (MPa)	10.4 min.	11.77 min.	7.0 min	26.04
Elongation (%)	250 min.	500 min.	300 min.	633.32
Hardness	65+5	-*	60±5	46.45
Aging (change in)				
• Tensile strength	8.3		-25	-22.34
• Elongation at break (%)	200		-35	-23.37
• Hardness	+5		+10, -5	+1.3

* This property was not studied, min. refers to minimum value.

Table 4.10 shows that tensile strength and elongation of rubber compound in this work are higher than standard properties of all rubber products. Therefore, CPS can be used as a sulfur donor type vulcanizing agent in rubber compound. However, the hardness of rubber compound in this work is lower than the standard hardness. Addition of carbon black into rubber compounds obtained from this work is required in order to increase hardness of the rubber. It also tended to be high if the carbon black was used at a higher amount.



ศูนย์วิทยทรัพยากร
จุฬาลงกรณ์มหาวิทยาลัย