

CHAPTER II

MATERIALS AND METHODS

Materials

(A) Chemical for preformulation studies

1. Butylated hydroxyanisole (BHA) : Merck-Schuchardt, Germany.
2. Carbomer 934 : Distributed by S.Tong Chemical Co., Ltd.Thailand.
3. Colloidal silicon dioxide (Aerosil®) : Wacker chemical GmbH Munchen, Germany.
4. Dibutyl Phthalate-DBP : Electron Microscopy Sciences, Fort Washington, USA.
5. Dichloromethane AR : Mallinckrodt, Inc. Kentucky, USA.
6. Disodium hydrogen phosphate : E. Merck, D-6100 Darmstadt, F.R., Germany.
7. Ethylene/vinyl acetate copolymer (vinyl acetate content 40%) : Aldrich chemical company, USA.
8. Glycerin : Distributed by Srichand United Dispensary Co., Ltd, Thailand.
9. Hydrochloric acid : J.T. Baker Inc. Phillipsburg, USA.
10. S (-) Nicotine : Fluka chemical AGCH-9470 Buchs, Switzerland.
11. 1-Octanol : Fluka Chemika AGCH-9470 Buchs, Switzerland.
12. Ortho-Phosphoric acid 85% : E.Merck, D-6100 Darmstadt, F.R., Germany.
13. Paraffin liquid : Distributed by Srichand United Dispensary Co., Ltd, Thailand.
14. Pluronic F-127 : BASF corporation chemical division, New Jersey, USA.
15. Polyethylene glycol 400 : Distributed by Srichand United Dispensary Co., Ltd, Thailand.
16. Propylene glycol: Distributed by Srichand United Dispensary Co., Ltd, Thailand.
17. Silicone 350 : Distributed by S.Tong chemicals Co., Ltd., Thailand.
18. Simethicone: Distributed by Pharmaceutical Traders Co., Ltd., Thailand.

19. Sodium chloride : E.Merck, D-6100 Darmstadt, F.R., Germany.
20. Sodium dihydrogen phosphate : E. Merck, D-6100 Darmstadt, F.R., Germany.
21. Sodium EDTA : May and Baker Ltd., Dagenham, England.
22. Sodium sulfite : E. Merck, D-6100 Darmstadt, F.R., Germany.

(B) Chemicals for High Performance Liquid Chromatography

1. Glacial acetic acid : E. Merck, D-6100 Darmstadt, F.R.,Germany.
2. Methanol HPLC grade : J.T. Baker Inc., Phillipsburg, USA.
3. Sodium acetate : Farmitilia Carloerba, Italy.
4. Triethanolamine 99% : Distributed by Srichand United dispensary Co., Ltd.,Thailand.

Apparatus

1. Analytical balance : Sartorius model A 2005, Sartorius Ltd.,Co. Germany.
2. Hot Air Oven : Memmert,Type UL 80,Germany.
3. pH Meter : Pye Model 232, Pye Unichem Ltd., England.
4. Incubator : Memmert, Germany.
5. Vortex Mixer : Vortex Genie-2, model G-560E, Scientific Industries Inc., Bohermia, New York, USA.
6. Magnetic stirrer : Model SP-18420, Nuova 7 stir-plate, Sybron Thermolyne, USA.
7. Diffusion cell : Modified from Kerhary-Chien diffusion cell.
8. Spectrophotometer : Shimadzu model UV 180, Shimadzu Corporation, Kyoto, Japan.
9. High Performance Liquid Chromatography (HPLC):
 - Pump : Multiple solvent delivery system, Milton Roy model CM4000, Milton Roy, LDC division, Florida, USA.
 - UV Absorption detector : Milton Roy model CM 4000, Milton Roy, LDC division, Florida, USA.
 - Integrator : Computer integrator, Milton Roy model 4100, Milton Roy, LDC division, Florida, USA.



Methods

1. Analytical Methods and Conditions

1.1 Spectrophotometric Analysis of Nicotine

A Beckman DU-68 Spectrophotometer was employed to determine the maximum spectra of nicotine, it was performed by scanning the UV absorption in a wavelength range of 350-200 nm. A concentration of 40 $\mu\text{g/ml}$ nicotine in aqueous solution was prepared for scanning the maximum absorption wavelength. The procedure was done at an ambient condition with a scan speed of 750 nm/min. The characteristic peak was observed for nicotine at a maximum wavelength of 260 nm.

The absorbance value at the maximum wavelength of 260 nm was read and the correspondent nicotine concentration was calculated from the calibration curve. The calibration curve of nicotine was plotted between the concentration of drug as a function of the absorbance. The various concentrations of nicotine in phosphate buffer solutions (pH 2, 4, 6, 7, 8, and 10) were 10, 20, 30, 40, and 50 $\mu\text{g/ml}$, respectively. This calibration curve was used in the whole partition between n-octanol and aqueous buffer studies.

1.2 HPLC Analysis of Nicotine

Nicotine was quantitated by reversed-phase high performance liquid chromatography. The HPLC system was setted as follows :

column	: HPLC-reverse phase column; ODS Hypersil (C_{18}) 4.6 mm X 15 cm setted at an ambient temperature
injected volume	: 20 μl
flow rate	: 1.3 ml/min
pressure	: 2500 psi
detector	: UV detector wavelength was setted at 260 nm
chart speed	: 2 mm/min

Concentration of nicotine in the samples, taken from the receptor solution at predetermined intervals were determined by a

reverse phase HPLC as outlined above. The mobile phase used was a combination of 0.05 M sodium acetate : methanol (55:45 v/v) containing 1.3% triethanolamine ; the pH was adjusted to 4.2 with acetic acid (Berner, Mazzenga, Gargiulo and Steffens, 1992), The mixture solution was filtered through a 0.45 μm membrane filter and then was degassed by sonicating for 30 min prior to use. Under these conditions, excellent linearity and reproducibility were obtained between 5-200 $\mu\text{g/ml}$ of nicotine free base. Nicotine produced a very sharp, clear absorption peak at retention time of 3.30 min and dexamethasone (internal standard) at 7.35 min.

Standard solution containing 5-50 $\mu\text{g/ml}$ nicotine in mobile solution were prepared. Standard solution containing 5, 10, 20, 30, 40 and 50 $\mu\text{g/ml}$ of nicotine and 5 $\mu\text{g/ml}$ of dexamethasone in each dilution. The calibration curve was constructed by plotting the ratio of the peak area of nicotine and dexamethasone versus the concentration of nicotine.

2. Design of Improved Diffusion Cell

An *in-vitro* release and permeation study was carried out using a diffusion cell (Figure 13) modified from Franz diffusion cell (Chien and Valia, 1984), Keschary Chien diffusion cell (Keshary, 1985) and Patch cell (Mueller, Roberts and Scott, 1990). This diffusion cell consisted of two compartments. the donor compartment in the upper and the receptor compartment in the lower. The capacity of the receptor compartment was 60 ml and the cross-sectional area of the donor compartment which was corresponded to the effective permeation area of 12.5 cm^2 . In the meantime, the water-jacket compartment was extended to envelope a greater surface area of the receptor compartment than the Franz diffusion cell to provide a better temperature control and equilibrium release of drug.

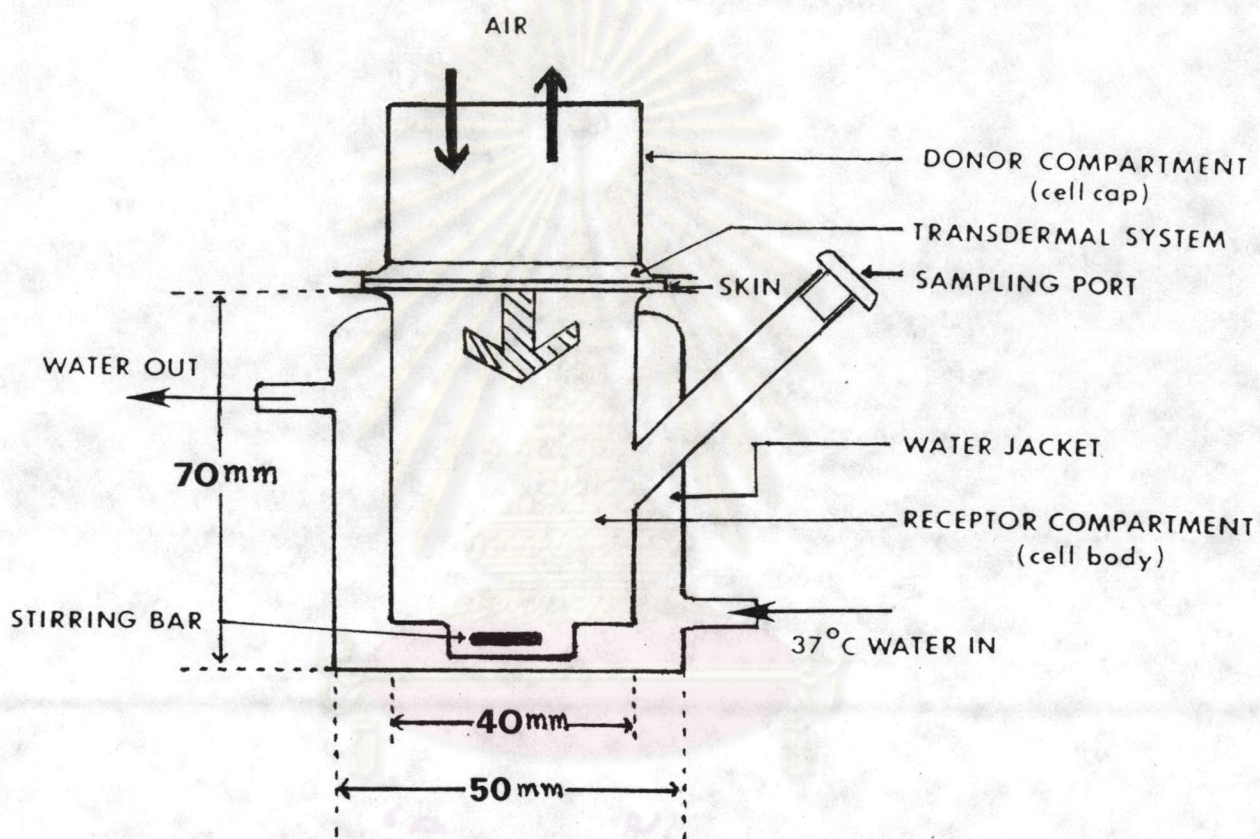

Figure 13 Schematic illustration of the modified diffusion cell used in this study.

3. Preparation of Transdermal Patch

The transdermal patch used in this study was prepared using impermeable backing membrane of heat sealable tan polyester film laminate. The membrane was obtained from non porous ethylene vinyl acetate which contain 9% vinyl acetate content. Scanning electron microscope can be observed in Figure 14. Ethylene vinyl acetate with vinyl acetate content less than 10% is not visibly attacked or dissolved by nicotine (Baker, et al., 1990). The adhesive layer of the system was hypoallergic acrylate pressure sensitive adhesive. The delivery device was protected using a release liner (Figure 15). Preparation of transdermal patch was cut backing membrane and EVA copolymer membrane into pieces (3.5 x 3.5 cm each) and sealed four rim with heat sealer. The system is square, multilaminate, which is then delivered across the rate-controlling membrane to the skin. A system with a contact surface area of 9 cm² and have a total nicotine content of 22.5 mg (2.5 mg/cm²) was used in this study.



Figure 14 Scanning electron microscope of ethylene vinyl acetate copolymer containing 9% vinyl acetate.

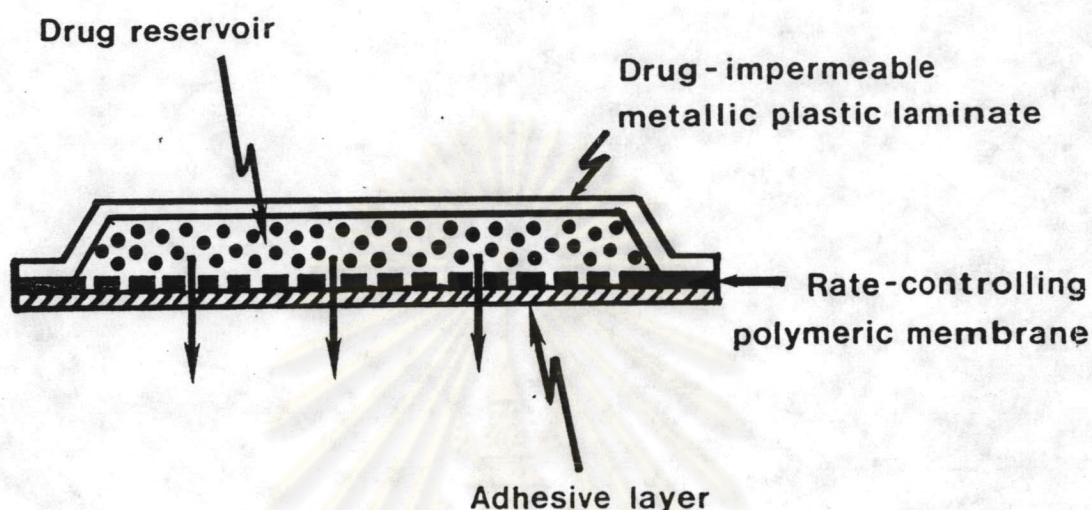

Figure 15 Cross sectional view of the rate-controlling membrane of TDS in this study (Kydonieus and Berner, 1987).

4. Skin Preparation

Permeation experiments were performed with full-thickness pig skin which were excised from a side of pigs. The age of the pig was 1-2 weeks. The whole skin was surgically removed and cleaned with sterile normal saline. The subcutaneous fat, tissue, blood vessel and epidermal hair were carefully removed by blunt section. The skin was free of obvious holes or defects. The full thickness skin was cleaned with normal saline and finally with sterile water, blotted dry, wrapped with aluminium foil and stored frozen before use. To perform *in-vitro* skin permeation experiment, full thickness skin was thawed at room temperature and cut into pieces (3.5 x 3.5 cm each) and a unit of nicotine-TDS was applied onto the stratum corneum surface of the skin and then mounted individually between the half-cells.

5. *In-vitro* Drug Release of Nicotine Patch

In-vitro drug release study was performed using a modified diffusion cell (as described in 4). The transdermal therapeutic system was clamped between the donor and the receptor compartments, with the drug releasing surface facing into the receptor compartment. The receptor compartment contained pH 7.4 isotonic phosphate buffer solution while the receptor compartment was maintained at $37\pm 1^\circ\text{C}$ by a circulating waterbath and controlled with a predetermined optimal stirring rate using a magnetic stirrer at 90 rpm. The donor compartment to be exposed to ambient temperature ($30\pm 1^\circ\text{C}$). Aliquots (1.0 ml each) were withdrawn at various time intervals (i.e. $\frac{1}{2}$, 1, 2, 3, 4, 6, 8, 10, 12, 14, 16, 20 and 24 hours) and was filled with the equal volume of freshly prepared (drug-free) isotonic phosphate buffer solution of pH 7.4. Samples were analyzed for nicotine concentration by the HPLC method.

6. *In-vitro* Skin Permeation of Nicotine Patch

The *in-vitro* skin permeation of nicotine from prepared membrane transdermal controlled systems was studied using a modified diffusion cell (as described in 4). The full-thickness pig skin was mounted onto the receptor compartment with the stratum corneum side facing upward into the donor compartment and the dermal side facing downward into the receptor compartment. A unit of prepared transdermal patch was placed over the skin with the drug-releasing surface in intimate contact with the stratum corneum and the whole assembly was clamped together with the donor cap on the top. The receptor compartment was then filled with the isotonic phosphate buffer solution pH 7.4 constantly stirred using a magnetic stirrer at 90 rpm and maintained at $37\pm 1^\circ\text{C}$ by a circulating waterbath. A portion (1.0 ml each) of buffer solutions were withdrawn from the receptor compartment at predetermined time intervals of $\frac{1}{2}$, 1, 2, 3, 4, 6, 8, 10, 12, 14, 16, 20 and 24 hours; the samples were replaced with an equal volume of freshly prepared pH 7.4 isotonic phosphate buffer solutions (drug-free). The nicotine concentrations in these samples were determined by the HPLC method.

7. Preformulation of Drug Reservoir for Nicotine-TDS

A. Non-aqueous Base Preformulation

1. Effect of Solvents/Vehicles on the Stability of Nicotine

Nicotine base was added to various solvents/vehicles, such as polyethylene glycol 400, propylene glycol, glycerin, mineral oil, silicone oil and simethicone, at 5% w/w concentration. Five ml Nicotine solutions were taken into six ml vials and closed with the rubber stopper and aluminium cap, accelerated the reaction by keeping in incubator at 45°C for 4 weeks and determined the color change of the nicotine in various solvents/vehicles at predetermined time interval.

2. Effect of Solvents/Vehicles on the Release and Skin Permeation of Nicotine Through Membrane, Adhesive and Skin

For release and skin permeation studies, 5% w/w nicotine solutions in various solvents/vehicles such as polyethylene glycol 400, propylene glycol, glycerin, mineral oil, silicone oil and simethicone were prepared and taken in a transdermal device (0.45 g/patch). The method of the release and skin permeation were described in 7 and 8 respectively. However, the time intervals of this study was 1, 2, 3, 4, 6, 8, 10 and 12 hours.

B. Aqueous Base Preformulation

1. Effect of pH Values on Preformulation of Nicotine-TDS

1.1 Effect of pH Values on Partition Coefficient

For partitioning in n-octanol, phosphate buffer solutions used for the aqueous phase and were prepared by mixing appropriate ratio of 0.1 M solutions of H_3PO_4 : NaH_2PO_4 (pH 2-4), NaH_2PO_4 : Na_2HPO_4 (pH 5-9) and Na_2HPO_4 : Na_3PO_4 (pH 10-12) (Oakley and Swarbrick, 1987). The pH values of buffer solutions were 2, 4, 6, 7, 8 and 10 (± 0.05 pH units), respectively. N-octanol and buffers were saturated overnight in a temperature controlled shaker bath and then separated. Nicotine base was dissolved in the buffer phase to achieve a concentration of 50 $\mu\text{g/ml}$. Then, 5 ml of buffer solution and 5 ml of n-octanol were pipetted into 20 ml of sealed centrifugal

tubes. The tubes were rotated in top to bottom rotator at room temperature (25°C) for 24 hours. After separating the two phases, the drug concentration in the aqueous phase was determined spectrophotometrically at 260 nm. The drug concentration in the n-octanol phase was calculated by abstraction from that found in the aqueous phase.

1.2 Effect of pH Values on the Stability of Nicotine

Studying the effect of pH values on the stability of nicotine, phosphate buffer solutions were prepared by mixing appropriate ratio of 0.1M solutions of H_3PO_4 : NaH_2PO_4 (pH 2-4), NaH_2PO_4 : Na_2HPO_4 (pH 5-9) and Na_2HPO_4 : Na_3PO_4 (pH 10-12). The pH values were adjusted to 2, 4, 6.5, 8.5 and 10.5, respectively. Nicotine base was dissolved in the buffer phase to achieve a concentration of 5 % w/w. Short-term stability studies were conducted by keeping in incubator at 45°C upto 4 weeks and then determined the stability by visually observed the color change of the solutions and also analyzed of nicotine recovering by the HPLC method.

1.3 Effect of pH Values on the Release and Skin Permeation of Nicotine Through Membrane, Adhesive and Skin

The buffer system that could stabilize nicotine was selected and also used as solvent for the drug reservoir in the transdermal device (3cm X 3cm each). The specifications of the components of the delivery device are described in 5. The quantity of 5% w/w nicotine, load to have nicotine 2.5 mg/cm² or 0.45 g/patch. The release and skin permeation of nicotine through membrane, adhesive and skin were described in 7 and 8, respectively. However, the time intervals of this study was 1, 2, 3, 4, 6, 8, 10 and 12 hours.

2. Effect of Antioxidant/Chelating Agent on the Stability of Nicotine

In order to study the effect of antioxidant/chelating agent on the stability of nicotine, 5% w/w nicotine in aqueous solutions was employed. The chelating agent selected in this study was sodium ethylenediaminetetraacetate (sodium EDTA) and the antioxidant was sodium sulfite. The ranges of concentration of sodium EDTA was 0.01-0.05 %w/w and sodium sulfite was 0.05-0.50 % w/w. The design of this study indicated in Table 5.

Additional short-term accelerated stability studies were conducted at 45°C for 4 weeks and the color change of the solution were observed.

Table 5 Experimental studies of the effect of antioxidant/chelating agent on nicotine stability

Experiment #	Conc. of nicotine (% w/w)	Conc. of sodium EDTA (% w/w)	Conc. of sodium sulfite (% w/w)
1	5.0	0.01	-
2	5.0	0.03	-
3	5.0	0.05	-
4	5.0	-	0.05
5	5.0	-	0.10
6	5.0	-	0.50
7	5.0	0.01	0.05
8	5.0	0.03	0.10
9	5.0	0.05	0.50

8. Formulation of Drug Reservoir for TDS

From the previous described experimental studies the effect of pH values, solvents/vehicles and chelating agent/antioxidant on the stability and release of nicotine were conducted. Then, the further study was the preparation of nicotine reservoir for TDS using the following three systems : (a) aqueous vehicles plus suitable gel polymer, chelating agent/antioxidant (b) nonaqueous vehicles plus suitable antioxidant that could stabilize nicotine and yielded a higher release rate : (c) preparation nicotine in EVA copolymer film as matrix system.

8.1 Preparation of Nicotine-carbomer 934

Carbomer 934 was used as a gel forming polymer in the formulation of nicotine in aqueous solution. This investigation was to study the effect of carbomer concentration on *in-vitro* drug release and skin permeation. The water was divided into two parts. To one large part, an appropriate amount of carbomer resin was added in small increments with constant stirring using a magnetic stirrer. After all the resin was added, the stirring was continued for about 30 minutes at a reduced speed in order to prevent the entrapment of air. An appropriate quantity of nicotine was added and the additives were dissolved in the other part of water and mixed with the carbomer mixture and triethanolamine was added to adjust pH, thus resulting in a stiff gel.

8.2 Preparation of Nicotine-pluronic F-127

The required amount of pluronic F-127 was slowly added to cold water and mixed. An appropriate quantity of nicotine was added and the additives were dissolved in a small part of water and then added, and mixed together. The pH was adjusted to. The obtained dispersion was stored overnight in a refrigerator to deaerate and form a clear viscous solution.

8.3 Preparation of Nicotine-EVA Copolymer (40% vinyl acetate)

Ethylene vinyl acetate copolymer (vinyl acetate content 40%) was used for preparing of drug reservoir in order to establish the effect of quantity of polymer on drug release, 10 percent polymer was used for the preparation of drug reservoir. Methylene chloride was used for polymeric solvent. 5% w/w Dibutyl phthalate was incorporated based on the polymer weight as a plasticizer. 10% w/w Propylene glycol was employed based on the polymer weight as a cosolvent. The drug reservoir films were prepared similar to the method developed by Deepak Thassu and S.P.Vyas (1993). Portions of 5, 10, 15 and 20 ml of the solution were poured into glass rings with the area of 63.62 cm². The thickness of the film were controlled by pouring constant volume of polymer solution of known concentration of nicotine in the glass ring of the same diameter and dimensions. After complete evaporation of the solvent at room temperature, the films were removed from the glass ring and cut in 3 x 3 cm² and inserted in the transdermal patch at the drug reservoir layer.

9. Evaluation of Nicotine TDS Formulations

Each formulation consisted of a fixed concentration of nicotine (2.5 mg/cm²) which was equal to that of Nicotinell®-TTS. Various preparations were compared for stability study by storage at 45°C for 4 weeks. In addition, the release of nicotine transdermal drug delivery preparations were also conducted. The formulations were put into the transdermal patch (described in 3) at drug reservoir layer. The method of *in-vitro* drug release and skin permeation was done as previously described in 5 and 6, respectively. The results were compared to that of Nicotinell®-TTS.