

ผลกระทบของกลุ่มประชากรแอมโมเนียออกไซด์ซึ่งค้แบคทีเรียในไนตริไฟอิงแอกทีเวเต้ดสลัดจ์ที่  
เพาะเลี้ยงและสลัดจ์จากระบบบำบัดน้ำเสียจริงในการย่อยสลาย17แอลฟา-เอทีนิวเอสตระไดออกอล  
โดยกระบวนการเมตาโบลีซึ่มร่วม

นางสาวนภสวรรณ คงขำ

วิทยานิพนธ์นี้เป็นส่วนหนึ่งของการศึกษาตามหลักสูตรปริญญาวิทยาศาสตรมหาบัณฑิต  
สาขาวิชาการจัดการสิ่งแวดล้อม (สหสาขาวิชา)  
บัณฑิตวิทยาลัย จุฬาลงกรณ์มหาวิทยาลัย  
ปีการศึกษา 2551  
ลิขสิทธิ์ของจุฬาลงกรณ์มหาวิทยาลัย

EFFECT OF AMMONIA OXIDIZING BACTERIA COMMUNITIES IN  
ENRICHED NITRIFYING ACTIVATED SLUDGE AND SLUDGE FROM FULL  
SCALE WASTEWATER TREATMENT PLANTS ON DEGRADATION OF  
17 $\alpha$ -ETHYNYLESTRADIOL VIA CO-METABOLISM.

Miss Napasawan Khongkham

A Thesis Submitted in Partial Fulfillment of the Requirements  
for the Degree of Master of Science Program in Environmental Management  
(Interdisciplinary Program)  
Graduate School  
Chulalongkorn University  
Academic Year 2008  
Copyright of Chulalongkorn University

Thesis Title


EFFECT OF AMMONIA OXIDIZING BACTERIA  
COMMUNITIES IN ENRICHED NITRIFYING  
ACTIVATED SLUDGE AND SLUDGE FROM FULL  
SCALE WASTEWATER TREATMENT PLANTS ON  
DEGRADATION OF 17 $\alpha$ -ETHYNYLESTRADIOL VIA  
CO-METABOLISM.

By  
Field of Study  
Advisor

Miss Napasawan Khongkham  
Environmental Management  
Tawan Limpiyakorn, Ph.D.

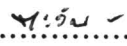
---

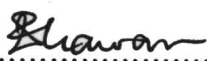
Accepted by the Graduate School, Chulalongkorn University in Partial  
Fulfillment of the Requirements for the Master's Degree


  
..... Dean of the Graduate School  
(Associate Professor Pornpote Piumsomboon, Ph.D.)


THESIS COMMITTEE

  
..... Chairman  
(Assistant Professor Manaskorn Rachakornkij, Ph.D.)

  
..... Advisor  
(Tawan Limpiyakorn, Ph.D.)

  
..... Examiner  
(Assistant Professor Ekawan Luepromchai, Ph.D.)

  
..... Examiner  
(Associate Professor Alissara Reungsang, Ph.D.)

  
..... External Examiner  
(Sorawit Powtongsook, Ph.D.)

นางสุวรรณ คงขำ : ผลกระทบของกลุ่มประชากรแอมโมเนียออกซิไดซิงค์แบคทีเรียในไนไตรไฟอิงแอกทิเวเตดสลัดจ์ที่เพาะเลี้ยงและสลัดจ์จากระบบบำบัดน้ำเสียจริงในการย่อยสลาย 17  $\alpha$ -เอทินิวเอสตราไดโวลโดยกระบวนการเมตาโบลิซึมร่วม (EFFECT OF AMMONIA OXIDIZING BACTERIA COMMUNITIES IN ENRICHED NITRIFYING ACTIVATED SLUDGE AND SLUDGE FROM FULL SCALE WASTEWATER TREATMENT PLANTS ON DEGRADATION OF 17 $\alpha$ -ETHYNYLESTRADIOL VIA CO-METABOLISM.) อ.ที่ปรึกษา  
วิทยานิพนธ์หลัก : อ. ดร. ตะวัน ลิ้มปิยากร, 76 หน้า.

แอมโมเนียออกซิไดซิงค์แบคทีเรีย (AOB) มีประสิทธิภาพในการย่อยสลายสารอินทรีย์มลพิษที่ย่อยสลายยากหลายชนิดในระหว่างกระบวนการออกซิเดชันแอมโมเนีย โดยผ่านกระบวนการเมตาโบลิซึมร่วม 17 $\alpha$ -เอทินิวเอสตราไดโวล (EE2) เป็นฮอร์โมนสังเคราะห์เพศหญิงชนิดหนึ่ง ซึ่งเป็นส่วนประกอบหลักของยาเม็ดคุมกำเนิด EE2 ถูกปลดปล่อยจากมนุษย์โดยการขับถ่ายลงสู่สิ่งแวดล้อมซึ่งทำให้น้ำเสียชุมชนเป็นแหล่งสำคัญที่พบ EE2 การศึกษาก่อนหน้านี้พบว่า EE2 มีความคงทนในระบบบำบัดน้ำเสียแบบแอกทิเวเตดสลัดจ์ แต่สามารถย่อยสลายได้โดย AOB ในไนไตรไฟอิงแอกทิเวเตดสลัดจ์ (NAS) ระหว่างกระบวนการออกซิเดชันแอมโมเนีย อย่างไรก็ตาม การศึกษาทั้งหมดก่อนหน้านี้ได้ทำการศึกษาเฉพาะ AOB ที่มาจากการเพาะเลี้ยงด้วยอาหารเลี้ยงเชื้อที่มีความเข้มข้นของแอมโมเนียสูงมาก ดังนั้นการศึกษานี้จึงมุ่งเน้นที่จะศึกษารูปแบบการย่อยสลาย EE2 (10 mg/L) โดย NAS ที่เพาะเลี้ยงขึ้น (ที่แอมโมเนียเริ่มต้น 2 และ 10 mM) และ สลัดจ์จากระบบบำบัดน้ำเสียจริง (จากระบบบำบัดน้ำเสียชุมชน 2 แห่ง และระบบบำบัดน้ำเสียโรงงานอุตสาหกรรม 2 แห่ง) ซึ่งกลุ่มประชากร AOB จากระบบบำบัดน้ำเสียทั้งหมดมีความแตกต่างกัน โดยกลุ่มประชากร AOB ใน NAS ที่เพาะเลี้ยงจากถังปฏิกรณ์ 2 และ 30 mM มีความแตกต่างของรูปแบบการย่อยสลาย EE2 โดย NAS ที่มีกลุ่มประชากร AOB ในกลุ่มความเข้มข้นของแอมโมเนียในระดับต่ำ (*Nitrosomonas oligotropha* cluster) จะสามารถย่อยสลาย EE2 ได้มากกว่า AOB ในกลุ่มความเข้มข้นของแอมโมเนียในระดับสูง (*Nitrosomonas europaea* cluster) ในสลัดจ์จากระบบบำบัดน้ำเสียชุมชน (MWWTP-A and MWWTP-B) AOB เป็นตัวทำหน้าที่หลักในการย่อยสลาย EE2 ในขณะที่ heterotrophs ย่อยสลาย EE2 เล็กน้อย ในทางตรงกันข้าม ในสลัดจ์จากระบบบำบัดน้ำเสียโรงงานอุตสาหกรรม (IWWTP-A and IWWTP-B) heterotrophs เป็นจุลินทรีย์สำคัญในการย่อย EE2 แนวโน้มของผลการทดลองแสดงให้เห็นว่าสลัดจ์ที่มีความแตกต่างกันของกลุ่มประชากร AOB แสดงรูปแบบการย่อยที่แตกต่างกัน โดย AOB ในกลุ่มความเข้มข้นของแอมโมเนียในระดับต่ำ (Unknown *Nitrosomonas* cluster, *Nitrosomonas communis* cluster และ *Nitrosomonas oligotropha* cluster, MWWTP-A, MWWTP-B, IWWTP-B) จะสามารถย่อยสลาย EE2 ได้มากกว่า AOB ในกลุ่มความเข้มข้นของแอมโมเนียในระดับสูง (*Nitrosomonas europaea*-*Nitrosomonas mobilis* cluster, IWWTP-A) อย่างไรก็ตามยังเป็นการยากที่จะสรุปผลดังกล่าวได้อย่างชัดเจน เนื่องจาก heterotrophs ทำหน้าที่ย่อย EE2 อย่างมีนัยสำคัญในสลัดจ์จากระบบบำบัดน้ำเสียจริงและไม่สามารถกละเลยได้

สาขาวิชา..... การจัดการสิ่งแวดล้อม..... ลายมือชื่อนิติติ..... นภศกวรรณ..... ๑๖/๑.....  
ปีการศึกษา 2551..... ลายมือชื่อ อ.ที่ปรึกษาวิทยานิพนธ์หลัก..... ๗๘๙ -

## 508 75214 20 : MAJOR ENVIRONMENTAL MANAGEMENT

KEYWORDS : 17 $\alpha$ -ETHYNYLESTRADIOL / AMMONIA-OXIDIZING BACTERIA / COMETABOLISM / DEGRADATION / NITRIFYING ACTIVATED SLUDGE

NAPASAWAN KHONGKHAM: EFFECT OF AMMONIA OXIDIZING BACTERIA COMMUNITIES IN ENRICHED NITRIFYING ACTIVATED SLUDGE AND SLUDGE FROM FULL SCALE WASTEWATER TREATMENT PLANTS ON DEGRADATION OF 17 $\alpha$ -ETHYNYLESTRADIOL VIA CO-METABOLISM. ADVISOR : TAWAN LIMPIYAKORN, Ph.D., 76 PP.

Ammonia oxidizing bacteria (AOB) has been reported for their capability of degrading several recalcitrant organic pollutants during ammonia oxidation by co-metabolism mechanism. 17 $\alpha$ -ethynylestradiol (EE2) is a synthetic female hormone that is the main component in oral contraceptive pill. EE2 can be released via human excretion causing the municipal sewage being an important source of EE2. Previous studies suggested that EE2 is persistent in contact with activated sludge but can be degraded by AOB in nitrifying sludge (NAS) during the oxidation of ammonia. However, all of the previous studies so far focused only on the AOB obtained from enriched NAS with extremely high ammonia levels. Therefore, this study, focused on the degradation patterns of EE2 (10 mg/L) by enriched NASs (with initial ammonium concentrations of 2 and 30 mM) and sludge from full-scale wastewater treatment plants (WWTPs) (two municipal and two industrial WWTPs) of which were different in AOB communities. AOB communities in enriched NASs from 2 and 30 mM reactors differed significantly. NASs from both reactors exhibited different degradation patterns of EE2. NAS containing AOB with high affinity to ammonia (*Nitrosomonas oligotropha* cluster) was able to degrade EE2 more than that with low affinity to ammonia (*Nitrosomonas europaea* cluster). In municipal sludge (MWWTP-A and MWWTP-B) AOB played a major role in EE2 degradation while small amounts of EE2 were degraded by heterotrophs. In contrast, in industrial sludge, heterotrophs were the one that degraded EE2 considerably. Results tended to showed that sludge with different AOB communities exhibited different degradation patterns of EE2. AOB with high affinity to ammonia (Unknown *Nitrosomonas* cluster, *Nitrosomonas communis* cluster and *Nitrosomonas oligotropha* cluster; MWWTP-A, MWWTP-B, IWWTP-B) was able to degrade more EE2 than AOB with low affinity to ammonia (*Nitrosomonas europaea*-*Nitrosomonas mobilis* cluster, IWWTP-A). However, it is hard to say this conclusion exactly as heterotrophs also played significant role in sludge from full-scale WWTPs and can not be neglected.

Field of Study: Environmental Management

Student's Signature: นางสาวณัฐพร อ.อ.อ.

Academic Year : 2008

Advisor's Signature: ท.อ.อ.อ.

## ACKNOWLEDGEMENTS

I do wish to express my graceful appreciation to Dr. Tawan Limpiyakorn who is my thesis advisor for the most valuable guidance and support during the entire of my study and for all the time, patience and suggestions and comments, I am greatly indebted.

Moreover, I would like to express my appreciation and sincere gratitude to Assistant Professor Manaskorn Rachakornkij who is a chairman of my thesis committee, Assistant Professor Ekawan Luepromchai, Associate Professor Alissara Reungsang, and Dr. Sorawit Powtongsook who are examiner for their suggestions and recommendations throughout my research work.

In addition, I would like to thank the National Center of Excellence for Environmental and Hazardous Waste Management (NCE-EHWM) for the scholarship, funding and supporting facilities for my study.

I also would like to thank the Bangkok Metropolitan Administration (BMA) for providing municipal wastewater samples and their information for this study.

Special thanks to Miss Chantana Intim who is a Laboratory coordinator and all staffs at NCE-EHWM program for their help especially in the analytical works.

The most thankful persons for Miss Supreeda Homklin, Mrs. Pantip Kayee, Miss Phanthipa Sonthipan, and Miss Natthawan Likitmongkonsakun. For the most useful help and gave me lots of good ideas, opinions and suggestions during my research work.

# CONTENTS

	<b>Page</b>
<b>ABSTRACT IN THAI</b> .....	iv
<b>ABSTRACT IN ENGLISH</b> .....	v
<b>ACKNOWLEDGEMENTS</b> .....	vi
<b>CONTENTS</b> .....	vii
<b>LIST OF TABLES</b> .....	xi
<b>LIST OF FIGURES</b> .....	xiii
<b>ABBREVIATIONS</b> .....	xviii
<b>CHAPTER I INTRODUCTION</b> .....	1
1.1 Background and motivation.....	1
1.2 Objectives.....	2
1.3 Hypotheses.....	2
1.4 Scope of the study.....	3
<b>CHAPTER II LITERATURE REVIEW</b> .....	4
2.1 Nitrogen .....	4
2.2 Nitrification.....	5
2.3 Ammonia oxidizing bacteria.....	6
2.3.1 General characteristics of genera of AOB.....	6
2.3.1.1 Genus Nitrosomonas .....	6
2.3.1.2 Genus Nitrospira.....	7
2.3.1.3 Genus Nitrosovibrio.....	7
2.3.1.4 Genus Nitrosolobus.....	8
2.3.1.5 Genus Nitrosococcus.....	8
2.3.2 Phylogeny of ammonia-oxidizing bacteria.....	9
2.3.3 Physiological properties of ammonia-oxidizing bacteria.....	12

	<b>Page</b>
2.3.4 Distribution of ammonia-oxidizing bacteria in WWTSs.....	13
2.4 Co-metabolism of organic compound by ammonia-oxidizing bacteria.....	14
2.5 Ethynylestradiol (EE2).....	15
2.5.1 Adverse effects of EE2.....	16
2.5.2 Effects of EE2 on living organisms.....	16
2.5.2.1 Effect of EE2 on human being.....	16
2.5.2.2 Effect of EE2 on aquatic organisms.....	16
2.5.2.3 Effect of EE2 on terrestrial organisms.....	17
2.6 Degradation of EE2 by AOB via co-metabolism.....	17
<b>CHAPTER III METHODOLOGY AND MATERIALS.....</b>	<b>18</b>
3.1 Experimental framework.....	18
3.2 Material and apparatus.....	19
3.2.1 Chemicals.....	19
3.2.1.1 Ethynylestradiol (EE2).....	19
3.2.2 Media.....	19
3.2.2.1 Medium for enriching nitrifying activated sludge...	19
3.2.2.2 Medium for degradation of EE2.....	19
3.2.3 Nitrifying activated sludge.....	20
3.3 Sample preparation and analytical methods.....	20
3.3.1 Sample preparation.....	20
3.3.2 Measurement of ammonium.....	20
3.3.3 Measurement of nitrite.....	21
3.3.4 Measurement of nitrate.....	21
3.3.5 Measurement of EE2.....	21



	<b>Page</b>
3.4 Enrichment of nitrifying activated sludge by inorganic medium containing different ammonium concentrations (2 and 30 mM)...	21
3.5 Degradation of EE2 by enriched NAS containing different ammonia-oxidizing bacterial communities.....	22
3.6 Collection of nitrifying activated sludge.....	23
3.7 Degradation of EE2 by sludge from full-scale WWTPs containing different ammonia-oxidizing bacterial communities.....	23
<b>CHAPTER IV RESULTS AND DISCUSSION.....</b>	<b>25</b>
4.1 Degradation of EE2 by enriched nitrifying activated sludge.....	25
4.1.1 Enrichment of nitrifying activated sludge by inorganic medium containing different ammonium concentrations of 2 and 30mM.....	25
4.1.2 Analysis of ammonia oxidizing bacterial communities in enriched nitrifying activated sludge.....	27
4.1.3 Degradation patterns of EE2 by enriched NASs under different ammonium concentrations (2 and 10mM).....	28
4.2 Degradation of EE2 by sludge from full-scale wastewater treatment plants.....	35
4.2.1 Collection of sludge from full-scale wastewater treatment plants.....	35
4.2.2 Analysis of ammonia oxidizing bacterial communities in sludge from full-scale wastewater treatment plants.....	37
4.2.3 Degradation patterns of EE2 by sludge from full-scale WWTPs under different ammonium concentrations (2 and 10mM).....	38
4.3 Degradation of EE2 by enriched nitrifying activated sludge and sludge from full-scale wastewater treatment plants.....	50

	<b>Page</b>
<b>CHAPTER V CONCLUSIONS AND SUGGESTIONS FOR FUTURE WORKS</b> .....	51
5.1 Conclusions.....	51
5.2 Suggestions for future works.....	52
<b>REFERENCES</b> .....	53
<b>APPENDICES</b> .....	55
<b>APPENDIX A</b> .....	56
<b>APPENDIX B</b> .....	63
<b>BIOGRAPHY</b> .....	76

## LIST OF TABLE

<b>Table</b>		<b>Page</b>
2.1	Physiological properties and preferred habitats of described AOB species.....	12
4.1	Summary of AOB found in enriched nitrifying activated sludge.....	27
4.2	Summarized values for degradation of EE2 by enriched nitrifying activated sludge.....	34
4.3	Detailed characteristics of full-scale wastewater treatment plants.....	36
4.4	Summary of AOB found in sludge from full-scale wastewater treatment plants.....	37
4.5	Summarized values for degradation of EE2 by sludge from full-scale WWTPs.....	49
A-1	Degradation of EE2 by enriched nitrifying activated sludge from 2mM reactor with initial ammonium concentrations of 2mM.....	57
A-2	Degradation of EE2 by enriched nitrifying activated sludge from 2mM reactor with initial ammonium concentrations of 10mM.....	58
A-3	Degradation of EE2 by enriched nitrifying activated sludge from 30mM reactor with initial ammonium concentrations of 2mM.....	59
A-4	Degradation of EE2 by enriched nitrifying activated sludge from 30mM reactor with initial ammonium concentrations of 10mM.....	60
B-1	Degradation of EE2 by sludge from MWWTP-A with initial ammonium concentrations of 2mM.....	64
B-2	Degradation of EE2 by sludge from MWWTP-A with initial ammonium concentrations of 10mM.....	65
B-3	Degradation of EE2 by sludge from MWWTP-B with initial ammonium concentrations of 2mM.....	66
B-4	Degradation of EE2 by sludge from MWWTP-B with initial ammonium concentrations of 10mM.....	67
B-5	Degradation of EE2 by sludge from IWWTP-A with initial ammonium concentrations of 2mM.....	68

<b>Table</b>		<b>Page</b>
B-6	Degradation of EE2 by sludge from IWWTP-A with initial ammonium concentrations of 10mM.....	69
B-7	Degradation of EE2 by sludge from IWWTP-B with initial ammonium concentrations of 2mM.....	70
B-8	Degradation of EE2 by sludge from IWWTP-B with initial ammonium concentrations of 10mM.....	71

## LIST OF FIGURES

<b>Figure</b>		<b>Page</b>
2.1	Nitrogen cycle.....	5
2.2	The genus <i>Nitrosomonas</i> . Phase contrast photomicrographs (A) and electron micrographs of thin sections (B) of cells of different <i>Nitrosomonas</i> species showing the variability of shapes and sizes and the details of their ultrastructure (intracytoplasmic membranes [IM] and carboxysomes [C]).....	7
2.3	The genus <i>Nitrospira</i> . Scanning electron micrograph (A) and electron micrograph of thin sections (B) of cells of <i>Nitrospira</i> species.....	7
2.4	The genus <i>Nitrosovibrio</i> . Scanning electron micrograph (A) and electron micrograph of thin sections (B) of cells of <i>Nitrosovibrio</i> species.....	8
2.5	The genus <i>Nitrosolobus</i> . Scanning electron micrograph (A) and electron micrograph of thin sections (B) of cells of <i>Nitrosolobus</i> species.....	8
2.6	The genus <i>Nitrosococcus</i> . Phase-contrast photomicrographs of whole cells (A) and electron micrographs of thin sections of cells (B) of <i>Nitrosococcus halophilus</i> . (C) Electron micrograph of a <i>Nitrosococcus halophilus</i> cell shadowed with chromium showing a tuft of flagella. (D) Freezeetch electron micrograph of <i>Nitrosococcus oceani</i> showing the macromolecular arrangement of the two layers outside of the envelope.....	9

<b>Figure</b>	<b>Page</b>
2.7 16S rRNA-based phylogenetic tree of the Betaproteobacterial AOB. Described species are depicted in bold. Maximum likelihood, maximum parsimony, and neighbor-joining trees were calculated and merged. Multifurcations connect branches for which a relative order cannot be unambiguously determined by applying different treeing methods. Filled and empty dots indicate parsimony bootstrap values (100 resamplings) above 90% and 70%, respectively. Scale bar represents 10% estimated sequence divergence.....	10
2.8 AmoA-based phylogenetic tree of the Betaproteobacterial AOB. Described species are depicted in bold. The 453-bp gene fragment obtainable with the most commonly used amoA PCR primers was used for phylogeny inference. AmoA sequences shorter than 414 nucleotides were excluded from the analysis. Protein maximum likelihood, protein maximum parsimony, neighbor-joining, and Fitch trees were calculated and merged. Multifurcations connect branches for which a relative order cannot be unambiguously determined by applying different treeing methods. Filled and empty dots indicate parsimony bootstrap values (100 resamplings) above 90% and 70%, respectively. Scale bar represents 10% estimated sequence divergence.....	11
2.9 FISH detection of an AOB microcolony in a nitrifying biofilm from a sequencing batch biofilm reactor. AOB were stained by probe NEU, and the fluorescence signals were recorded by confocal laser scanning microscopy. Probeconferred fluorescence is shown in yellow, while autofluorescence of the biofilm is depicted in blue. Bar = 10 $\mu$ m. The picture was kindly provided by Holger Daims.....	14
2.10 Co-metabolism of ethylene by AOB.....	15
2.11 Structures of Ethynylestradiol (EE2).....	15
3.1 Experimental framework.....	18

<b>Figure</b>	<b>Page</b>
3.2 Degradation of EE2 by enriched NAS containing different ammonia-oxidizing bacteria communities.....	23
3.3 Degradation of EE2 by sludge from full-scale WWTPs containing different ammonia-oxidizing bacteria communities.....	24
4.1 Concentrations of nitrogens during enrichment of nitrifying activated sludge of (a) 2 mM reactor and (b) 30 mM reactor.....	26
4.2 Degradation of EE2 by enriched nitrifying activated sludge from 2 mM reactor with initial ammonium concentrations of 2 mM : a) nitrogen concentrations, b) EE2 concentrations, and c) pH.....	30
4.3 Degradation of EE2 by enriched nitrifying activated sludge from 2 mM reactor with initial ammonium concentrations of 10 mM : a) nitrogen concentrations, b) EE2 concentrations, and c) pH.....	31
4.4 Degradation of EE2 by enriched nitrifying activated sludge from 30 mM reactor with initial ammonium concentrations of 2 mM : a) nitrogen concentrations, b) EE2 concentrations, and c) pH.....	32
4.5 Degradation of EE2 by enriched nitrifying activated sludge from 30 mM reactor with initial ammonium concentrations of 10 mM : a) nitrogen concentrations, b) EE2 concentrations, and c) pH.....	33
4.6 Degradation of EE2 by sludge from MWWTP-A with initial ammonium concentrations of 2 mM : a) nitrogen concentrations, b) EE2 concentrations, and c) pH.....	41
4.7 Degradation of EE2 by sludge from MWWTP-A with initial ammonium concentrations of 10 mM : a) nitrogen concentrations, b) EE2 concentrations, and c) pH.....	42
4.8 Degradation of EE2 by sludge from MWWTP-B with initial ammonium concentrations of 2 mM : a) nitrogen concentrations, b) EE2 concentrations, and c) pH.....	43
4.9 Degradation of EE2 by sludge from MWWTP-B with initial ammonium concentrations of 10 mM : a) nitrogen concentrations, b) EE2 concentrations, and c) pH.....	44

<b>Figure</b>	<b>Page</b>
4.10 Degradation of EE2 by sludge from IWWTP-A with initial ammonium concentrations of 2 mM : a) nitrogen concentrations, b) EE2 concentrations, and c) pH.....	45
4.11 Degradation of EE2 by sludge from IWWTP-A with initial ammonium concentrations of 10 mM : a) nitrogen concentrations, b) EE2 concentrations, and c) pH.....	46
4.12 Degradation of EE2 by sludge from IWWTP-B with initial ammonium concentrations of 2 mM : a) nitrogen concentrations, b) EE2 concentrations, and c) pH.....	47
4.13 Degradation of EE2 by sludge from IWWTP-B with initial ammonium concentrations of 10 mM : a) nitrogen concentrations, b) EE2 concentrations, and c) pH.....	48
A-1 First-order reaction kinetic of ammonium and estrogens during degradation of EE2 by enriched nitrifying activated sludge from 2 mM reactor with initial ammonium concentrations of 2 mM (a) and 10 mM (b).....	61
A-2 First-order reaction kinetic of ammonium and estrogens during degradation of EE2 by enriched nitrifying activated sludge from 30 mM reactor with initial ammonium concentrations of 2 mM (a) and 10 mM (b).....	62
B-1 First-order reaction kinetic of ammonium and estrogens during degradation of EE2 by nitrifying activated sludge from MWWTP-A with initial ammonium concentrations of 2 mM (a) and 10 mM (b).....	72
B-2 First-order reaction kinetic of ammonium and estrogens during degradation of EE2 by nitrifying activated sludge from MWWTP-B with initial ammonium concentrations of 2 mM (a) and 10 mM (b).....	73



<b>Figure</b>		<b>Page</b>
B-3	First-order reaction kinetic of ammonium and estrogens during degradation of EE2 by nitrifying activated sludge from IWWTP-A with initial ammonium concentrations of 2 mM (a) and 10 mM (b).....	74
B-4	First-order reaction kinetic of ammonium and estrogens during degradation of EE2 by nitrifying activated sludge from IWWTP-B with initial ammonium concentrations of 2 mM (a) and 10 mM (b).....	75

## ABBREVIATIONS

AMO	=	ammonia monooxygenase
AOB	=	ammonia-oxidizing bacteria
C18	=	octadecyl
Conc.	=	concentration
DGGE	=	denaturing gradient gel electrophoreses
DW	=	dry weight
EDs	=	endocrine disruptors
EE2	=	17 $\alpha$ -ethynylestradiol
EPA	=	environmental protection agency
g	=	gram
GC	=	gas chromatography
HAO	=	hydroxylamine oxidoreductase
HPLC	=	high performance liquid chromatography
Kow	=	octanol-water partitioning coefficient
LC	=	liquid chromatography
LOD	=	limit of detection
mg/L	=	milligram per liter
MW	=	molecular weight
NAS	=	nitrifying activated sludge
ng/L	=	nanogram per liter
NOB	=	nitrite-oxidizing bacteria
PCR	=	polymerase chain reaction
SPE	=	solid phase extraction
WWTP	=	wastewater treatment plant
WWTS	=	wastewater treatment system

# CHAPTER I

## INTRODUCTION

### 1.1 Background and motivation

Discharge of improperly treated wastewater into the natural receiving water is one of the major environmental problems in many countries. Wastewater treatment systems (WWTSs) have been developed along the last and this centuries and implemented to solve this problem. The major compounds that have been in concerns include organic matter, nitrogen, and phosphorous and some toxic compounds that exist in high amount (mg/L range) in wastewater. After the end of the last century since the mass spectrographic technique have been developed, a lot more compounds that are presence in tiny amounts ( $\mu\text{g/L}$  or  $\text{ng/L}$  range) have been observed. Some of them have been pointed out as micropollutants, the pollutant that exist in very small concentrations but can have significant effects to human health and eco systems. A good example of this is  $17\alpha$ -ethynylestradiol (EE2), the synthetic female hormones used as a main component in oral contraceptive pill. EE2 has been proven as a recalcitrant micropollutant in the environment. However, it has been reported that WWTSs can remove this compound to certain extend and this is probably done by ammonia oxidizing bacteria (AOB) in WWTSs. AOB has been reported for its capability of degrading several organic pollutants by co-metabolism mechanism (Keener et al., 1993). Co-metabolism is the second reaction of ammonia monooxygenase (AMO), the enzyme used for ammonia oxidation. In this case, AOB use ammonia as a primary substrate, and use electrons remain from this reaction in degrading organic compound as a secondary substrate. Therefore, co-metabolism is not about the process that produces energy. Thus this process can not occur without metabolism.

In fact, there are several species of AOB in nature. The species of AOB distribute based on their preference on the habitats. This depends on the environmental conditions in the habitats such as ammonia concentration, ammonia tolerance, salt requirement, salt tolerance, oxygen concentration, pH, etc (Koops et al., 2003). The

concentration of ammonia seem to be the most important factor reflecting the AOB distribution. In the environment with low ammonia levels, *Nitrosomonas oligotropha*, *Nitrosomonas communis* and *Nitrospira* clusters are generally dominant while in the environment with high ammonia levels *Nitrosomonas europaea* cluster dominate.

Many researches have studied the ability of AOB in degrading organic pollutants such as methane (CH<sub>4</sub>), ethylene (C<sub>2</sub>H<sub>4</sub>), EE2, and Trichloroethylene (TCE), etc (Keener et al., 1993; Vader et al., 2000). However, all the previous studies so far only focused on the classical isolated AOB, *Nitrosomonas europaea* or the nitrifying activated sludge (NAS) enriched with very high ammonia levels, so that comprised mainly the *Nitrosomonas europaea* cluster (Shi et al., 2004; Vader et al., 2000). Recently, Sermwaraphan et al., 2006 discovered that the degradation patterns of EE2 differed among NASs that contained different AOB communities. NASs from 3 reactors containing different AOB communities were tested for their ability to degrade 10 mg/L of EE2 under varying concentrations of ammonium (2, 10 and 30 mM NH<sub>4</sub><sup>+</sup>-N). The results demonstrated the similar EE2 degradation patterns (mgEE2/gNH<sub>4</sub><sup>+</sup>) for NAS from 2 mM and 10 mM reactors but different from those of 30 mM. However, this study only focused on enriched NASs which is still far different for the sludge from full-scale WWTSs. Whether the same phenomena will occur with the sludge from full-scale NASs or not is unclear. Therefore, this study aims to investigate the effect of AOB communities in enriched NAS and sludge from full-scale WWTPs on degradation of EE2.

## 1.2 Objective

1. To investigate the effect of AOB communities in enriched NASs on degradation of EE2 via co-metabolism.
2. To investigate the effect of AOB communities in sludge from full-scale WWTPs on degradation of EE2 via co-metabolism.

## 1.3 Hypotheses

1. AOB is the major microorganisms in NASs that degrade EE2.
2. Degradation patterns of EE2 by enriched NASs reflects those by sludge from full-scale WWTPs.

**1.4 Scope of the study**

1. This study focuses on the AOB communities in enriched NASs and sludge from full-scale WWTPs.
2. Enriched NASs will be carried out in laboratory-scale continuous-flow reactors.
3. Sludge will be taken from full-scale municipal and industrial WWTPs.
4. Degradation study will be carried out in laboratory-scale batch tests.

## **CHAPTER II**

### **LITERATURE REVIEW**

#### **2.1 Nitrogen cycle**

Nitrogen is the most of gas that is found in atmosphere. The process of the nitrogen cycle occurs by atmospheric nitrogen is converted to ammonia or nitrates. Nitrogen is the component in all living systems. Becoming a part of an organism nitrogen must first be combined or fixed with oxygen or hydrogen. Nitrogen is eliminated from the atmosphere by lightening and nitrogen fixing bacteria. During electrical storms, large amounts of nitrogen are oxidized and united with water to produce a kind of acid which is carried to the earth in rain producing nitrates. Plants take up nitrates and change them into proteins.

After that the nitrogen passes through the food chain from all kinds of plants to herbivores to carnivores. When animals and plants eventually die, the nitrogen compounds are broken down giving ammonia (ammonification). The plants take up some of the ammonia ; and some of it is dissolved in water or held in the soil where bacteria change it into nitrates (nitrification). Nitrates may be leached from the soil and carried to lakes and streams or stored in humus. It may also be changed into free nitrogen (denitrification) and returned to the atmosphere. The figure 2.1 show nitrogen cycle (The Michigan Water Research Center[MWRC], 2008).

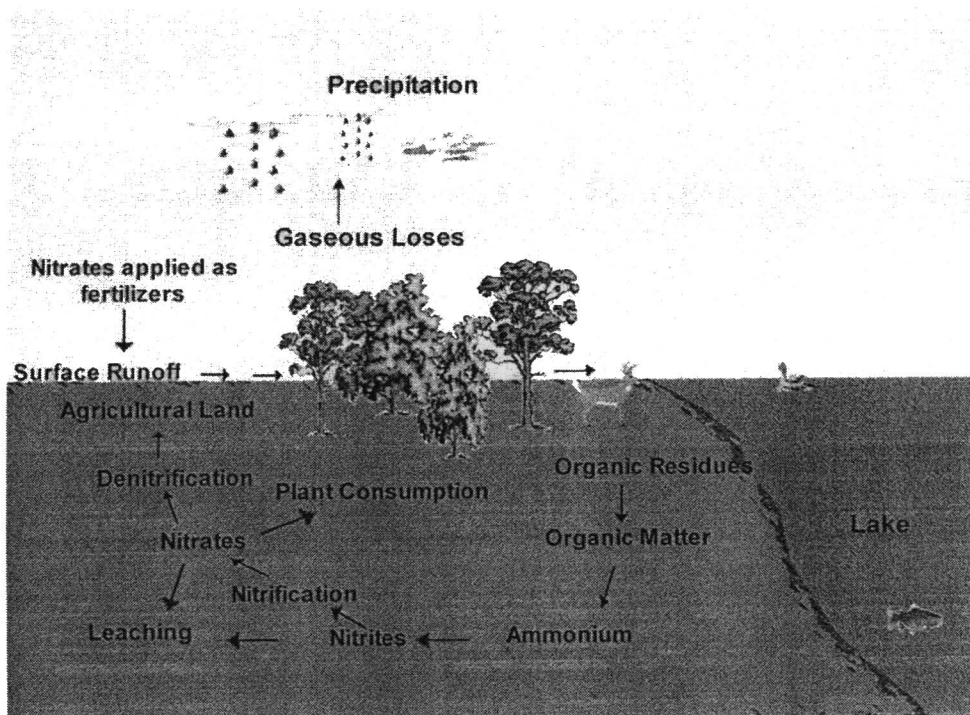


Figure 2.1 Nitrogen cycle  
Available from: MWRC (2008)

## 2.2 Nitrification

The biological oxidation of ammonia with oxygen into nitrite followed by the oxidation of these nitrites into nitrates is called nitrification. Degradation of ammonia to nitrite is usually the rate limiting step of nitrification. Nitrification is an important step in the nitrogen cycle in soil. This process was discovered by Sergei Winogradsky, the Russian microbiologist.

The oxidation of ammonia into nitrite is done by two groups of organisms, ammonia oxidizing archaea and ammonia oxidizing bacteria. Ammonia oxidizing bacteria can be found among the  $\beta$ - and  $\gamma$ -proteobacteria. In soils the most studied about ammonia oxidizing bacteria belong to the genera *Nitrosococcus* and *Nitrosomonas*. Though in soils ammonia oxidation occurs by both archaea and bacteria in harsher environments like oceans ammonia oxidation is controlled by archaea. The second step (oxidation of nitrite into nitrate) is mainly done by bacteria of the genus *Nitrobacter*. The both steps are bringing about energy to be coupled to ATP synthesis. Nitrifying organisms are chemoautotrophs, and use carbon dioxide as their carbon source for growth (Treusch et al., 2005).

Nitrification also plays an important role in the removal of nitrogen from municipal wastewater. The common removal is nitrification, followed by denitrification. The cost of this process resides mainly in aeration (bringing oxygen in the reactor) and the addition of an exterior carbon source (for example : methanol) for the denitrification.

In the most of environments both organisms are found together, yielding nitrate as the last product. It is possible to design systems in which specially nitrite is formed (the Sharon process).

Together with ammonification, nitrification forms a mineralization process which concerns to the complete decomposition of organic material, with the liberation of available nitrogen compounds. This refills the nitrogen cycle (MWRC, 2008).

## **2.3 Ammonia-oxidizing bacteria**

### **2.3.1 General characteristics of the genera of AOB**

On the basis of the shape of cells, the original isolation was categorized into genera. Later, the grouping of their intracytoplasmic membranes was brought as a second basic character. Using these criteria, the genera *Nitrosomonas*, *Nitrosococcus*, *Nitrospira*, *Nitrosolobus* and *Nitrosovibrio* have been set up. In the following, a brief listing of the distributing morphological features of the five recognized genera of AOB is given and the separate cultured species are described.

#### **2.3.1.1 Genus *Nitrosomonas***

Cells commonly are rod shaped or spherical. Extensive intracytoplasmic membranes are arranged as peripherally located flattened vesicles. Sometimes thrusts of membranes into the protoplasm are observed (Figure 2.2).



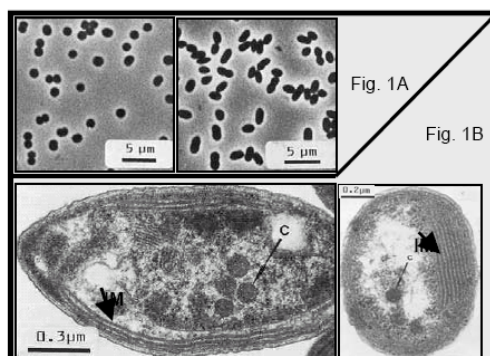


Figure 2.2 The genus *Nitrosomonas*. Phase contrast photomicrographs (A) and electron micrographs of thin sections (B) of cells of different *Nitrosomonas* species showing the variability of shapes and sizes and the details of their ultrastructure (intracytoplasmic membranes [IM] and carboxysomes [C]) (Koops et al., 2003).

### 2.3.1.2 Genus *Nitrospira*

Cells are densely closed spirals and occasionally vibrio shaped. Extensive intracytoplasmic membranes are absent. Thrusts of membranes into the protoplasm are sporadically observed (Figure 2.3).

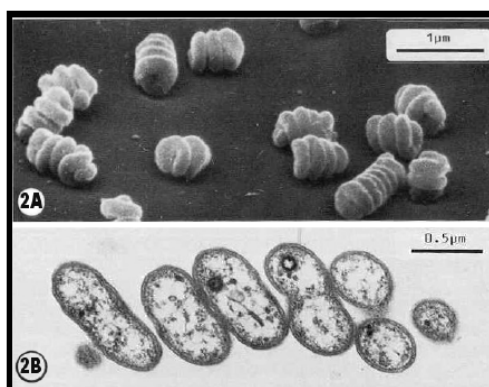


Figure 2.3 The genus *Nitrospira*. Scanning electron micrograph (A) and electron micrograph of thin sections (B) of cells of *Nitrospira* species (Koops et al., 2003).

### 2.3.1.3 Genus *Nitrosovibrio*

Cells are vibrio shaped. Extensive intracytoplasmic membranes are absent. Thrusts of membranes into the protoplasm are documented (Figure 2.4).

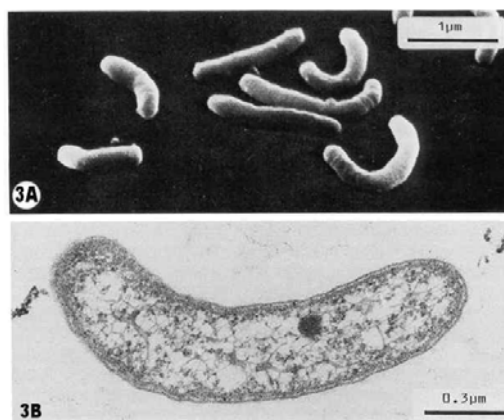


Figure 2.4 The genus *Nitrosovibrio*. Scanning electron micrograph (A) and electron micrograph of thin sections (B) of cells of *Nitrosovibrio* species (Koops et al., 2003).

#### 2.3.1.4 Genus *Nitrosolobus*

Cells are pleomorphic lobes compartmentalized by the cytoplasmic membrane (Figure 2.5).

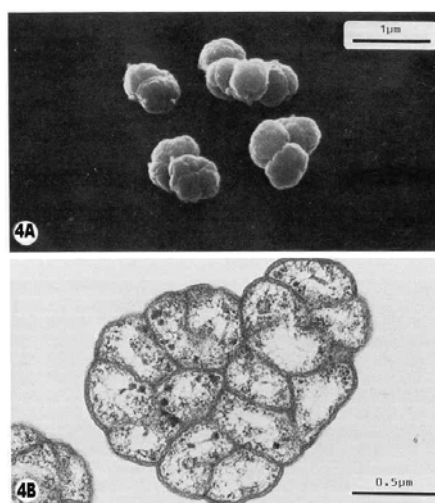


Figure 2.5 The genus *Nitrosolobus*. Scanning electron micrograph (A) and electron micrograph of thin sections (B) of cells of *Nitrosolobus* species (Koops et al., 2003).

#### 2.3.1.5 Genus *Nitrosococcus*

This genus only symbolises the gamma-proteobacterial AOB. Both explained species, *N. oceani* and *N. halophilus*, are characterized by large spherical to ellipsoidal cells exposing extensive intracytoplasmic membranes, arranged as a focal stack of vesicles (Figure 2.6).

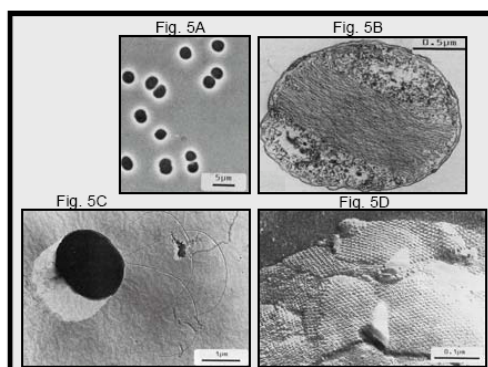


Figure 2.6 The genus *Nitrosococcus*. Phase-contrast photomicrographs of whole cells (A) and electron micrographs of thin sections of cells (B) of *Nitrosococcus halophilus*. (C) Electron micrograph of a *Nitrosococcus halophilus* cell shadowed with chromium showing a tuft of flagella. (D) Freezeetch electron micrograph of *Nitrosococcus oceani* showing the macromolecular arrangement of the two layers outside of the envelope (Koops et al., 2003).

### 2.3.2 Phylogeny of ammonia-oxidizing bacteria

The prevalent understanding of evolutionary relationships and the natural diversity of AOB is based on comparative sequence analyses of their genes encoding the 16S rRNA genes and *amoA* genes the gene that encode enzyme ammonia monooxygenase (AMO). Comparison of 16S rRNA gene sequence analyses of cultured AOB that found members of physiological group are limited to two monophyletic lineages within the *Proteobacteria*: *Gammaproteobacteria* and *Betaproteobacteria*. The *Gammaproteobacteria* have *Nitrosococcus oceani* is the member, despite members of the genera *Nitrosomonas* (including *Nitrosococcus mobilis*), *Nitrospira*, *Nitrosolobus* and *Nitrosovibrio* from a closely related grouping within the *Betaproteobacteria* (Perkhold et al., 2000). Figure 2.7 shows a phylogenetic 16S rRNA based tree of those AOB indicated to represent different genospecies (DNA-DNA similarity less than 60% and/or 16 rRNA sequence similarity less than 97.5%). Recently, the coding of *amoA* gene for the active site polypeptide of the ammonia monooxygenase has been increased to used in phylogenetic marker molecule for AOB. Phylogeny conclusion based on the inferred amino acid sequence of the *amoA* gene fragment is overall consistent with the 16S rRNA phylogeny of AOB (Figure 2.8) (Koops et al., 2003).

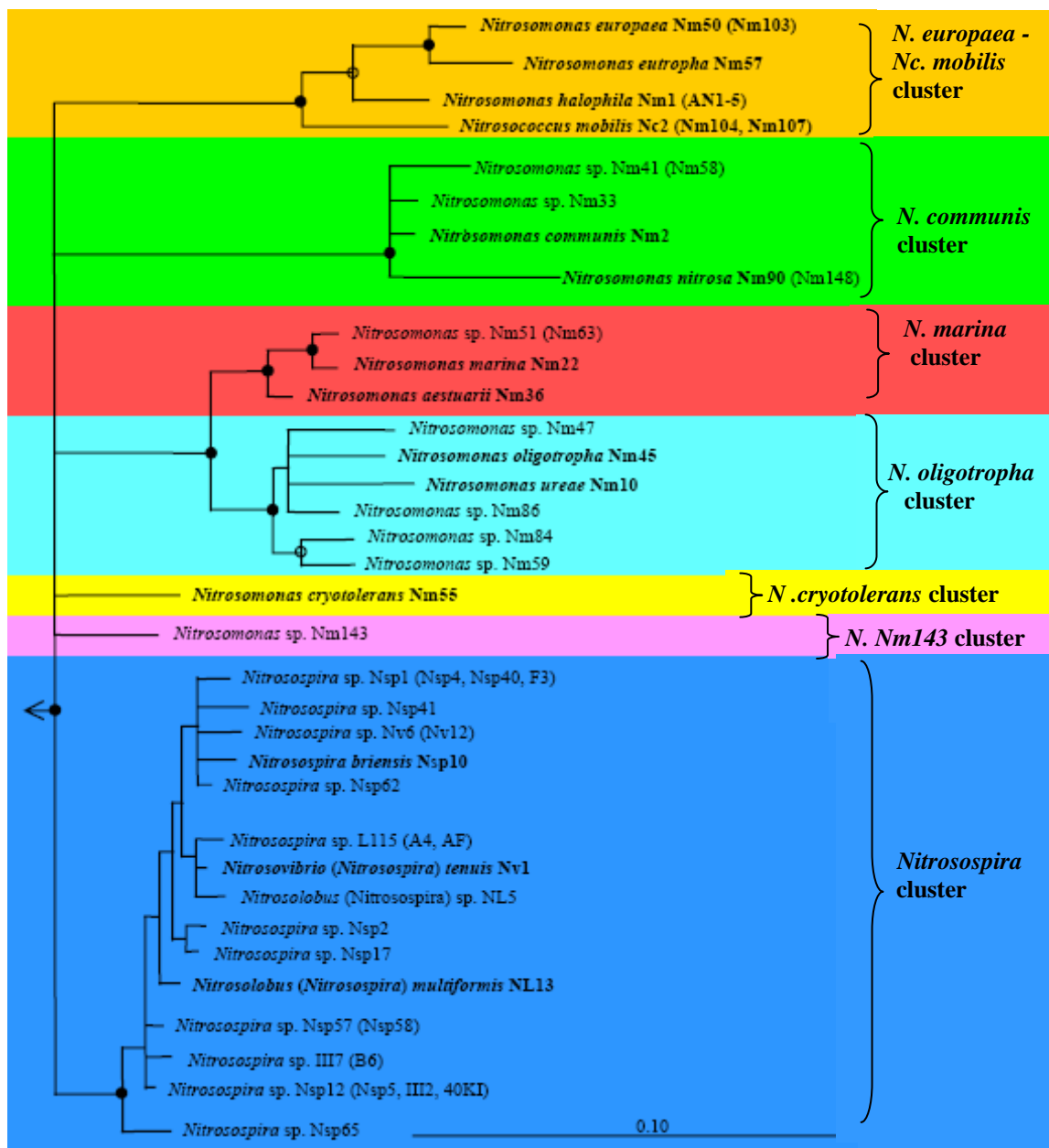


Figure 2.7 16S rRNA-based phylogenetic tree of the *Betaproteobacterial* AOB. Described species are depicted in bold. Maximum likelihood, maximum parsimony, and neighbor-joining trees were calculated and merged. Multifurcations connect branches for which a relative order cannot be unambiguously determined by applying different treeing methods. Filled and empty dots indicate parsimony bootstrap values (100 resamplings) above 90% and 70%, respectively. Scale bar represents 10% estimated sequence divergence

Available from: Koops et al. (2003)

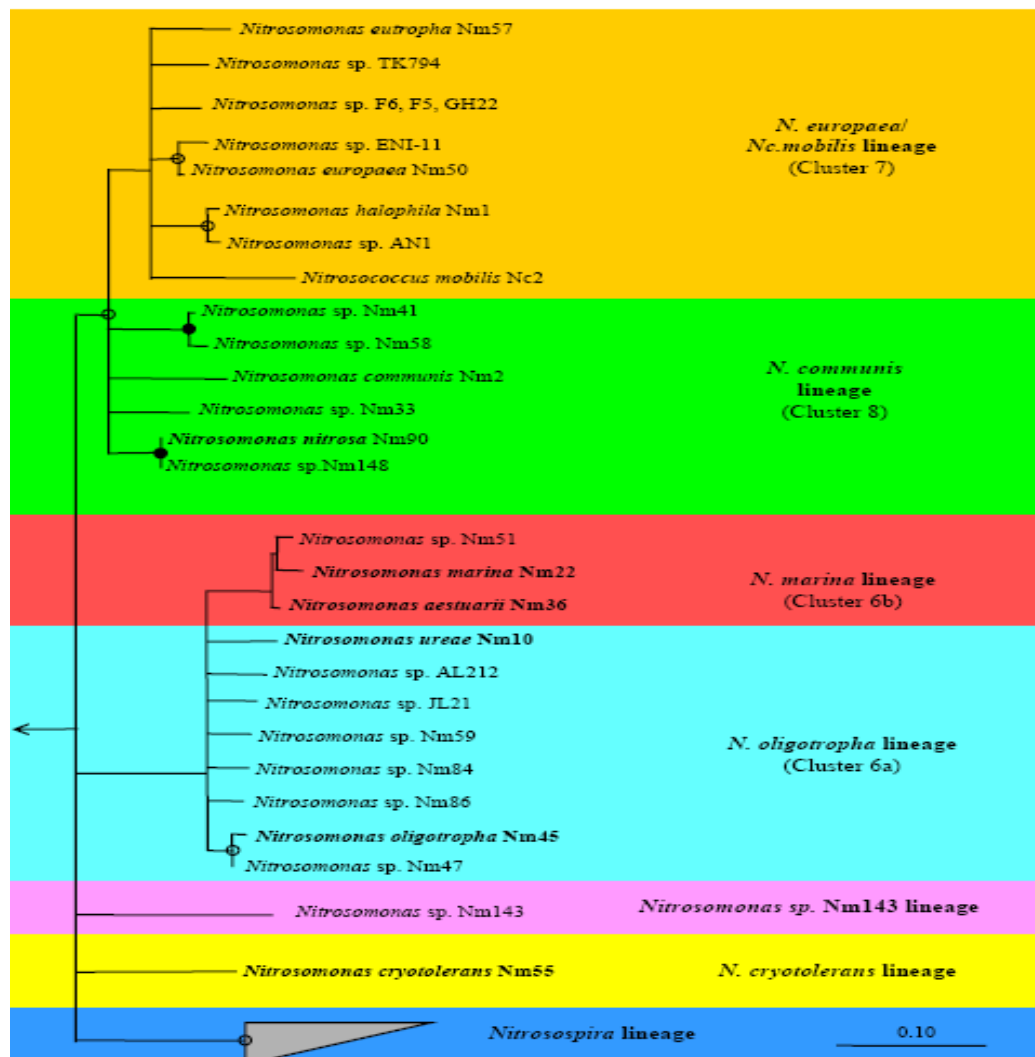


Figure 2.8 AmoA-based phylogenetic tree of the *Betaproteobacterial* AOB. Described species are depicted in bold. The 453-bp gene fragment obtainable with the most commonly used *amoA* PCR primers was used for phylogeny inference. AmoA sequences shorter than 414 nucleotides were excluded from the analysis. Protein maximum likelihood, protein maximum parsimony, neighbor-joining, and Fitch trees were calculated and merged. Multifurcations connect branches for which a relative order cannot be unambiguously determined by applying different treeing methods. Filled and empty dots indicate parsimony bootstrap values (100 resamplings) above 90% and 70%, respectively. Scale bar represents 10% estimated sequence divergence.

Available from: Koops et al. (2003)

### 2.3.3 Physiological properties of ammonia-oxidizing bacteria

Ammonia as an only energy source that All of AOB used. But the characterization of AOB differ importantly among species and diverse distribution patterns of evident species in different habitats (Koops et al., 2003).

Table 2.1 Physiological properties and preferred habitats of described AOB species  
Available from: Koops et al. (2003)

Species	G+C (mol %)	Substrate (NH <sub>3</sub> ) affinity (K <sub>s</sub> in μM)	Maximum ammonia tolerance NH <sub>4</sub> Cl (in mM ; pH 8.0)	Salt Requirement	Maximum salt tolerance (in mM)	Preferred habitats
<i>N. europaea</i>	50.6–51.4	30–61	400	–	400	Sewage disposal plants, freshwater and brackish water
<i>N. eutropha</i>	47.9–48.5		600	–	400	
<i>N. halophila</i>	53.8		400	+	900	
<i>Nc. mobilis</i>	49.3		250	+	500	
<i>N. communis</i>	45.6–46.0	14–43	250	–	250	Soils (not acid) and eutrophic freshwater Oligotrophic freshwater and natural soils
<i>N. nitrosa</i>	47.9	19–46	100	–	300	
<i>N. ureae</i>	45.6–46.0	1.9–4.2	200	–	200	
<i>N. oligotropha</i>	49.4–50.0		50	–	150	
<i>N. marina</i>	47.4–48.0	50–52	200	+	800	Marine environments
<i>N. aestuarii</i>	45.7–46.3		400	+	600	
<i>N. cryotolerans</i>	45.5–46.1	42–59	400	+	550	
<i>Ns. multiformis</i>	53.5	ND	50	–	200	Soils (not acid)
<i>Ns. tenuis</i>	53.9	ND	100	–	100	Soils, rocks and freshwater
<i>Ns. briensis</i>	54	ND	200	–	250	

Symbols and Abbreviations: +, present; –, not present; +/-, present in some strains; and ND, no data.

#### 2.3.4 Distribution of ammonia-oxidizing bacteria in WWTSs.

In industrial wastewater treatment plants (WWTPs), cultivated representatives of members of the *N. oligotropha* lineage as well as *N. nitrosa* has been usually reported. In laboratory experiments, an outstanding high tolerant members of the *N. oligotropha* lineage to heavy metals was observed, and the production of significant amounts of exopolymeric materials by these species was indicated to be the main reason for this tolerance. This resistance to heavy metals may be accountable for the attendance of members of this lineage in special WWTPs. During the last decade, molecular techniques were widely applied to characterize AOB community structure and activity in activated sludge and biofilm from diverse WWTPs. FISH shown that AOB regularly occur in firm microcolonies formed of up to several thousand individual cells (Figure 2.9). These microcolonies can be hard dispersed using ultrasonic or Ultraturrax homogenizer treatments and then contribute to the underestimation of AOB numbers in MPN assays. Typically, the AOB are discovered in situ in close nearness to nitrite oxidizers reflecting the mutualistic relationship between both guilds. The test using to combining of FISH with <sup>14</sup>C-bicarbonate microautoradiography indicated that almost all of AOB microcolonies in activated sludge are physiologically active. Moreover, AOB in WWTPs can combine pyruvate. Using quantitative FISH data, the particular activity of a single AOB cell in activated sludge has been estimated to be  $2.3 \pm 0.4$  fmol of ammonia per hour. According to FISH analyses, *nitrosomonads* are predominant over *nitrosospiras* in most activated sludge and biofilm systems. With the exception of *Nitrosomonas cryotolerans*, *Nitrosomonas halophila* and *Nitrosomonas sp.* Nm143, relevant of all the another *Nitrosomonas* species happen in WWTPs. *Nitrosococcus mobilis*, originally thought to be confined to brackish water, is abundant in many WWTPs. Some nitrifying WWTPs are dominated by a single AOB species, while the another plants shelter a high diversity of AOB. Whether and how differences in diversity of ammonia oxidizers are connected to the stability of the nitrification process is not answered the question. The examinations of AOB populations in the raw sewage most probably also could give significant insight into AOB diversity in sewage disposal plants (Koops et al., 2003).

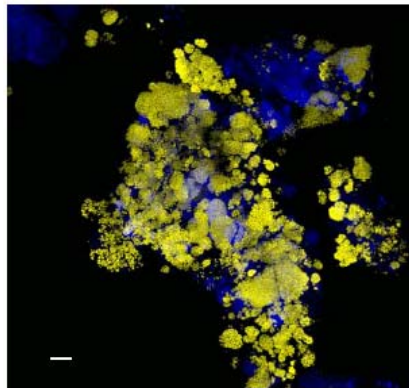


Figure 2.9 FISH detection of an AOB microcolony in a nitrifying biofilm from a sequencing batch biofilm reactor. AOB were stained by probe NEU, and the fluorescence signals were recorded by confocal laser scanning microscopy. Probeconferred fluorescence is shown in yellow, while autofluorescence of the biofilm is depicted in blue. Bar = 10  $\mu\text{m}$ . The picture was kindly provided by Holger Daims.

Available from: Koops et al. (2003)

#### **2.4 Co-metabolism of organic compound by ammonia-oxidizing bacteria**

AOB is obligate chemolithotrophic aerobe using ammonia as an only energy source and it is widely for the oxidation of hydrocarbon substrates through the action of ammonia monooxygenase (AMO) (Arciero, Vannelli, and Hooper, 1989).

For the process of oxidation of ammonia to nitrite, AMO catalyzes the oxidation of ammonia to hydroxylamine. Later, hydroxylamine is oxidized to nitrite by hydroxylamine oxidoreductase (HAO). During the last process four electrons are liberated. Two electrons transfer to AMO in order to activate oxygen and continue steady-state rate of ammonia oxidation. And the other two electrons are used in other oxidation reaction which is called co-metabolism (Arciero et al., 1989; Keener and Arp, 1993). Nowadays, AOB can degrade many hydrocarbons and halogenated hydrocarbons via co-metabolism such as in Figure 2.10 show ethylene is degraded by co-metabolism of AOB.



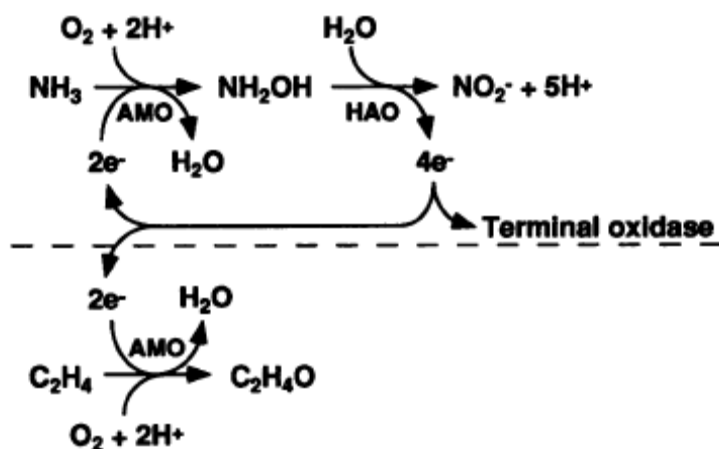
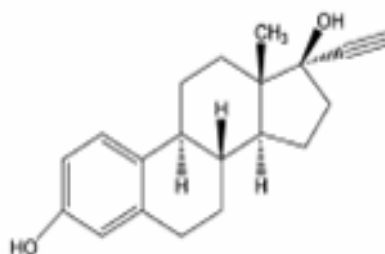


Figure 2.10 Co-metabolism of ethylene by AOB

Available from: Keener and Arp (1993)

## 2.5 Ethynylestradiol (EE2)

17 $\alpha$ -ethynylestradiol (EE2) as the synthetic estrogen is a regularly used oral contraceptive that has been increasingly detected in the effluent of WWTSs (Figure 2.11) (Irvin et al, 2003). Therefore, this compound used to hormone therapy as treated menopausal woman who suffer from lack of hormone . Adverse effects have been reported in fish exposed to this compound, such as vitellogenin induction or alteration of gonad structure. EE2 has the molecular weight equal 296.4 ,water solubility is 4.8 mg/l at 20°. Vapor pressure is  $4.5 \times 10^{-11}$  mmHg and Log Kow of EE2 is 4.15 (Sermwaraphan et al, 2006).



Ethynylestradiol (EE2)

Figure 2.11 Structures of Ethynylestradiol (EE2)

Available from: Sermwaraphan (2006)

### **2.5.1 Adverse effects of EE2**

Endocrine disruptors have negative impact to human and animal by interfere with the regular function of endocrine and reproductive system of human and animal. The definition of endocrine disruptors from US Environmental Protection Agency (EPA) is: “*An exogenous agent that interferes with the synthesis, secretion, transport, binding, action, or elimination of natural hormones in the body that are responsible for the maintenance of homeostasis, reproduction, development, and/or behavior*”. Estrogenic endocrine disruptor compounds are comprise of natural hormones and pharmaceutical estrogens, phytoestrogens, surfactants, pesticides and industrial compounds. Even though, pesticide, surfactants, and industrial compounds are not estrogen hormones, But they have negative impact to living organism the same as estrogens by interfere with endocrine and reproductive system of human and animal also (Institute of Population Health, 2007).

### **2.5.2 Effects of EE2 on living organisms**

#### **2.5.2.1 Effect of EE2 on human being**

The estrogens can enter into the human via food or drinking water. And it's may be caused decreasing of sperm count, increasing of incident of testicular cancer and male fertility disorder in human (Sharp and Skakkeback, 1993).

#### **2.5.2.2 Effect of EE2 on aquatic organisms**

Endocrine disruptors affect on living organisms that live near the contaminated area when they enter into environment. Water from wastewater treatment plant is discharged into water resources such as river, reservoir, lake, and ocean. Then, aquatic organisms in theirs are directly affected by endocrine disruptor. Aquatic organisms can exposure to endocrine disruptor compounds especially natural hormone and pharmaceutical estrogens that remain in effluent of wastewater. Estrogen contamination of waterways is involved because low concentrations (10-100 ng/L) of estrogens in water can adversely affect the reproductive biology of vertebrate species such as fish, turtles, and frogs by disrupting the normal function of their endocrine systems (Hanselman et al., 2003). For instance, 1 ng/L of E2 can lead to the induction of vitellogenin (an egg yolk precursor protein that is normally produced only by adult females) in male trout (Desbrow et al., 1998; Jobling et al., 1998). A laboratory study on the endocrine disrupting potency of EE2 indicated that EE2 at low

concentrations of 1-10 ng/L caused estrogenic response in caged fish (Purdom et al., 1994) and these changes may be expressed later in the life cycle or even in future generations.

### **2.5.2.3 Effect of EE2 on terrestrial organisms**

EE2 may interfere with the normal functioning of endocrine systems and affect reproduction and development in wildlife (Jobling et al., 1998). The effect of steroid hormones in the environment may be not only wildlife but also plants. Shore, Correll, and Charkraborty (1995) reported that Alfalfa irrigated with effluent in municipal, which contained steroid hormones, was observed to have elevated levels of phytoestrogens.

## **2.6 Degradation of EE2 by AOB via co-metabolism.**

Ammonium monooxygenase activity is mediated in EE2 degradation. AOB can co-metabolise many low molecular weight organic compounds. The pathway of ammonium oxidation is started by the enzyme ammonium monooxygenase. The insertion of oxygen into C-H bonds can carry out by Monooxygenases. Ammonium monooxygenase catalyses, for example, the hydroxylation of alkanes to produce primary and secondary alcohols. The activity of nitrifying activated sludge probably results in hydroxylation, transforming EE2 into hydrophilic products. Co-metabolic process is the degradation of EE2 by nitrifying micro-organisms. Co-metabolic conversions are thought to play a important role in the degradation of xenobiotic compounds in nature. Recently, pH was reported to have the effect to removed EE2 in abiotic condition. The investigate that was indicated the removal of EE2 at pH below 7.0 (Gaulke et al., 2008).

Nitrifying bacteria are widespread in the environment. As they can degrade EE2 without prior adaptation, it can be concluded that these bacteria influent a sink for EE2 in various environmental compartments and activated sludge systems. EE2 may be a non-competitive inhibitor of ammonia oxidation because it not competes with ammonia for oxidation by the enzyme of AMO (Vader et al., 2000). But, it may competes with another compound via co-metabolism.

# CHAPTER III

## METHODOLOGY

### 3.1 Experimental framework

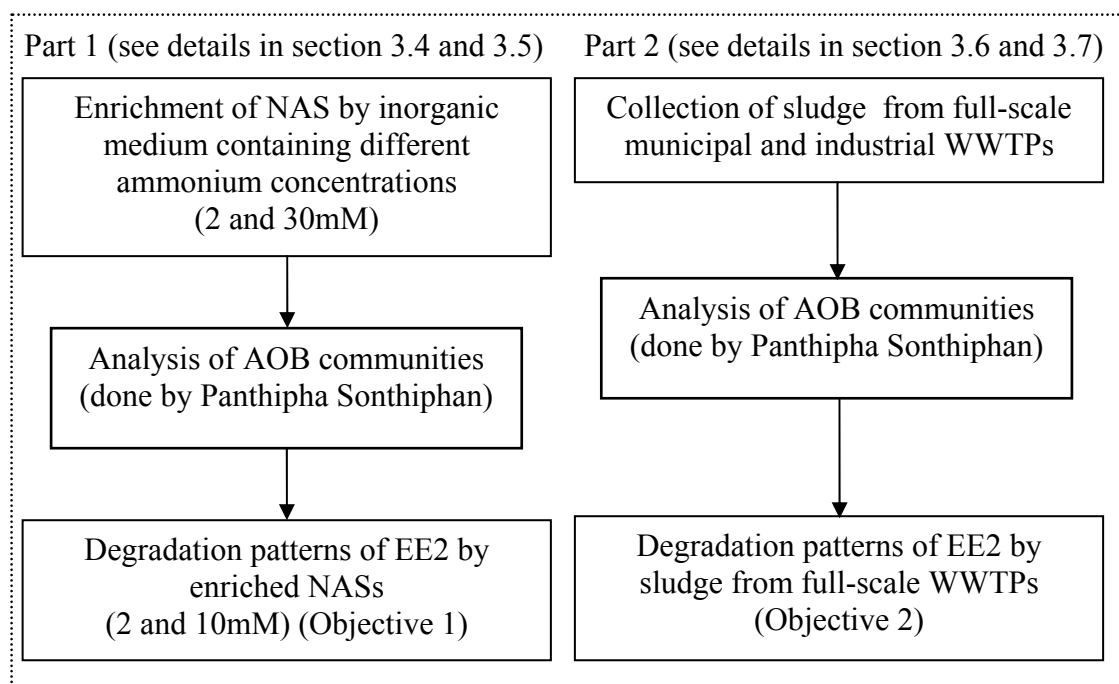


Figure 3.1 Experimental framework

The main part of this study concerns the effect of AOB communities in enriched NASs and sludge from full-scale WWTPs on degradation of EE2 via co-metabolism. The criteria to select the enriched NASs and the sludge from full-scale WWTPs was the ammonium level in the influent, as this is the most important factor in selecting AOB communities in the environment. AOB communities in each NASs and sludge were analyzed using molecular techniques in another work done by Sonthiphan(2008) on the topic of communities of ammonia oxidizing bacteria and archaea in full-scale WWTPs in Thailand. Then, each NAS or sludge was tested for their abilities to degrade EE2. The experiment was divided into 2 parts as in Figure 3.1. The first part concerned to the enriched NAS and the second part involved the sludge from full-scale WWTPs.

In the first part, sludge from a municipal WWTPs was enriched in continuous-flow reactors receiving inorganic medium containing different ammonium concentrations of 2 and 30 mM. AOB with low affinity to ammonia such as *Nitrosomonas oligotropha*, *Nitrosomonas communis* or *Nitrospira* were expected to dominant in 2mM reactor while AOB with high affinity to ammonia such as *Nitrosomonas europaea* and were thought to be predominant in 30mM reactor. Then these two enriched NASs were tested for their ability to degrade EE2 under initial ammonium concentration of 2 and 10mM. In the second part, sludge were taken from four full-scale WWTPs that received wastewater containing different levels of ammonia. Then the sludge from full-scale WWTSs were tested for their degradation patterns in degrading EE2 under initial ammonium concentrations of 2 and 10mM.

## 3.2 Materials and apparatus

### 3.2.1 Chemicals

#### 3.2.1.1 Ethynylestradiol (EE2)

EE2 (>98% pure) was purchased from Sigma (St.Louis, MO, USA). Stock solutions of EE2 was prepared to 50 mg/L in methanol.

### 3.2.2 Media

#### 3.2.2.1 Medium for enriching nitrifying activated sludge

The inorganic medium for enriching NAS contained  $(\text{NH}_4)_2\text{SO}_4$ , 40 mg of  $\text{MgSO}_4 \cdot 7\text{H}_2\text{O}$ , 40 mg of  $\text{CaCl}_2 \cdot 2\text{H}_2\text{O}$ , 200 mg of  $\text{KH}_2\text{PO}_4$ , 1 mg of  $\text{FeSO}_4 \cdot 7\text{H}_2\text{O}$ , 0.1 mg of  $\text{Na}_2\text{Mo}_4\text{O}_4 \cdot 2\text{H}_2\text{O}$ , 0.2 mg of  $\text{MnCl}_2 \cdot 4\text{H}_2\text{O}$ , 0.02 mg of  $\text{CuSO}_4 \cdot 5\text{H}_2\text{O}$ , 0.1 mg of  $\text{ZnSO}_4 \cdot 7\text{H}_2\text{O}$ , and 0.002 mg of  $\text{CoCl}_2 \cdot 6\text{H}_2\text{O}$  per liter (Limpiyakorn et al., 2007).  $\text{NaHCO}_3$  was added to achieve 2 mg bicarbonate ( $\text{HCO}_3^-$ ) per 1 mg of ammonium added. pH was adjusted to around 7.5-8.0 using 40 g/L  $\text{NaHCO}_3$ .

#### 3.2.2.2 Medium for degradation of EE2

The inorganic medium for degradation of EE2 by NAS contained  $(\text{NH}_4)_2\text{SO}_4$ ,  $\text{NaHCO}_3$ , 40 mg of  $\text{MgSO}_4 \cdot 7\text{H}_2\text{O}$ , 40 mg of  $\text{CaCl}_2 \cdot 2\text{H}_2\text{O}$ , 200 mg of  $\text{KH}_2\text{PO}_4$ , 1 mg of  $\text{FeSO}_4 \cdot 7\text{H}_2\text{O}$ , 0.1 mg of  $\text{Na}_2\text{Mo}_4\text{O}_4 \cdot 2\text{H}_2\text{O}$ , 0.2 mg of  $\text{MnCl}_2 \cdot 4\text{H}_2\text{O}$ , 0.02 mg of  $\text{CuSO}_4 \cdot 5\text{H}_2\text{O}$ , 0.1 mg of  $\text{ZnSO}_4 \cdot 7\text{H}_2\text{O}$ , and 0.002 mg of  $\text{CoCl}_2 \cdot 6\text{H}_2\text{O}$ , 5 g of  $\text{CaCO}_3$ , 4 g of HEPES, and 0.5% phenol 10 mg/L (modified from Limpiyakorn et al., 2007).

Nitrogen gas flow was purged to remove methanol and then 5 mL of inorganic medium described above was added.

### **3.2.3 Nitrifying activated sludge**

Two types of NASs were used in this study. First type was NASs enriched in continuous-flow reactor receiving inorganic medium containing different ammonium concentrations of 2 and 30mM. Details of these NASs can be obtained from section 3.4. Second type was NASs taken from full-scale WWTPs. The criteria to select WWTS was ammonia concentrations in the influent, the most important factor in the inclusion of AOB in the environments. Therefore, the selected WWTPs included both municipal and industrial WWTPs. Municipal WWTPs (Chong-nonsi and Dindang) represented the systems receiving low ammonia level wastewater while industrial WWTPs (food industry and slaughter-house) represented those receiving high ammonia level wastewater.

## **3.3 Sample preparation and analytical methods**

### **3.3.1 Sample preparation**

One mL of liquid medium was taken from test tubes to analyze for nitrogen concentrations. Equal volume of methanol (4 mL) was added into test tube containing remaining liquid medium (4 mL). Test tube was then vortexed to allow completely dissolving EE2.

### **3.3.2 Measurement of ammonium**

Sample was diluted with deionized water. 5 mL of dilution sample and 0.2 mL of phenol solution (Mix 11.1 mL liquefied phenol ( $\geq 89\%$ ) with 95% v/v ethyl alcohol to a final volume of 100 mL) were added and then mixed. 0.2 mL of sodium nitroprusside solution (0.5% w/v: dissolve 0.5 g of sodium nitroprusside in 100 mL of deionized water), and 0.5 mL of oxidizing solution (Mix 100 mL alkaline citrate solution: dissolve 200 g of trisodium citrate and 10 g of sodium hydroxide in 1000 mL of deionized water with 25 mL of sodium hypochloride) were added into the tube. Sample was covered with plastic wrap or paraffin wrapper film and kept at room temperature in subdued light for at least 1 hr to develop color. Sample was measured for absorbance at 640 nm with UV visible spectrophotometers (Thermo Electron

Corporation, Hexious  $\alpha$ , Cambridge, UK) (Phenate method, Standard Method for the Examination of Water and Wastewater 20<sup>th</sup> edition).

### **3.3.3 Measurement of nitrite**

Sample was diluted with deionized water. 5 mL of diluted sample and 0.1 mL of Sulphanilamide solution (dissolve 5 g of Sulphanilamide and 50 mL of hydrochloric in 500 mL) was added, and allowed to react 5 min, then 0.1 mL of NNED solution (dissolve 1 g of (N-(1-Naphthyl)-Ethylenediamine Dihydrochloride in 1000 mL of de-ionized water) was added and allowed at room temperature in subdued light for at least 1 hr to develop color . Sample was measured for absorbance at 543 nm with UV visible spectrophotometers (Thermo Electron Corporation, Hexious  $\alpha$ , Cambridge, UK) (Phenate method, Standard Method for the Examination of Water and Wastewater 20<sup>th</sup> edition).

### **3.3.4 Measurement of nitrate**

Sample was diluted with deionized water. 5 mL of diluted sample was filtered and measured for absorbance at 220 nm to obtain  $\text{NO}_3^-$  reading and absorbance at 275 nm to determine interference due to dissolved organic matter with UV visible spectrophotometers (Thermo Electron Corporation, Hexious  $\alpha$ , Cambridge, UK) (Phenate method, Standard Method for the Examination of Water and Wastewater 20<sup>th</sup> edition).

### **3.3.5 Measurement of EE2**

One mL of inorganic medium added with methanol was filtered through 0.45  $\mu\text{m}$  filter. EE2 was analyzed using High Performance Liquid Chromatography (HPLC; Agilent 1100 Series LC, Germany) with UV diode array detector (Agilent 1100 Series LC, Germany) at  $\lambda = 210$  nm. Elution was carried out by using 40 % v/v acetonitrile/water at a flow rate of 1 mL/min with retention time of 15 min (Weber et al., 2005). Retention time of EE2 is 11.524 min, respectively.

## **3.4 Enrichment of nitrifying activated sludge by inorganic medium containing different ammonium concentrations (2 and 30 mM)**

This experiment aimed to develop NAS containing different AOB communities. Sludge taken from the municipal wastewater treatment system was

enriched in two laboratory-scale continuous flow reactors without sludge recycling introduced with inorganic medium containing two different ammonium concentrations: 2 and 30 mM  $\text{NH}_4^+\text{-N}$  (28 and 420 mg N/L, respectively). Total volume of each reactor was 6 L, with an effective volume of 3 L. To obtain the optimum condition for AOB growth, temperature was kept at the room temperature, pH was maintained in a range of 7.5-8.0 using 1 N HCl and 1 N NaOH. Inorganic medium was introduced into all reactors at a fixed dilution rate of  $0.01 \text{ hr}^{-1}$  (Limpiyakorn et al., 2007).

### **3.5 Degradation of EE2 by enriched NAS containing different ammonia-oxidizing bacterial communities**

This experiment aimed to study degradation patterns of EE2 by enriched NAS containing different AOB communities, NASs were tested for their ability to degrade 10 mg/L of EE2 under varying concentrations of ammonium (2 and 10 mM  $\text{NH}_4^+$ ). The tests comprising of degradation test, inhibition test and control test were performed in triplicate (Figure 3.2). In the degradation test, NAS was added into 5 mL of inorganic medium containing EE2 (10 mg/L) and varying concentration of ammonium (2 and 10 mM  $\text{NH}_4^+$ ) to obtain final MLSS concentration of 300 mg/L. The inhibition test and control test were prepared in the same manner as the degradation test except that for inhibition test, allythiourea (10 mg/L) (Shi et al., 2004) was added to inhibit ammonia oxidation by AOB and for the control test, no NAS was added. The cultivations were at  $25^\circ\text{C}$  with rotating speed of 250 rpm. Samples in each tube were taken at time 0, 24, 48, 72, 96, 144, 192, 240, 288 and 336 hr. Concentrations of ammonium, nitrite, nitrate, EE2 were analyzed as described previously.



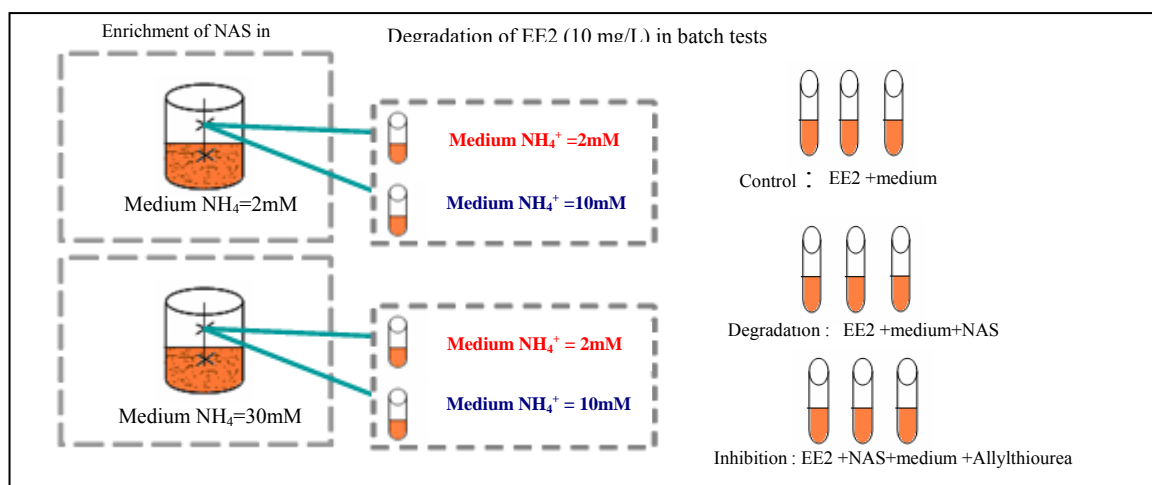


Figure 3.2 Degradation of EE2 by enriched NAS containing different ammonia-oxidizing bacteria communities

### 3.6 Collection of nitrifying activated sludge

Sludge from full-scale WWTPs were collected as described in 3.2.3. Sludge were kept at 4°C and before used, they were activated by aeration for 3-4 hours at room temperature.

### 3.7 Degradation of EE2 by sludge from full-scale WWTPs containing different ammonia-oxidizing bacterial communities

This experiment aimed to study degradation patterns of EE2 by sludge from full-scale WWTPs containing different AOB communities. The experimental approaches are as described in section 3.5 (MWWTP-A, MWWTP-B, IWWTP-A, and IWWTP-B) (Figure 3.3).

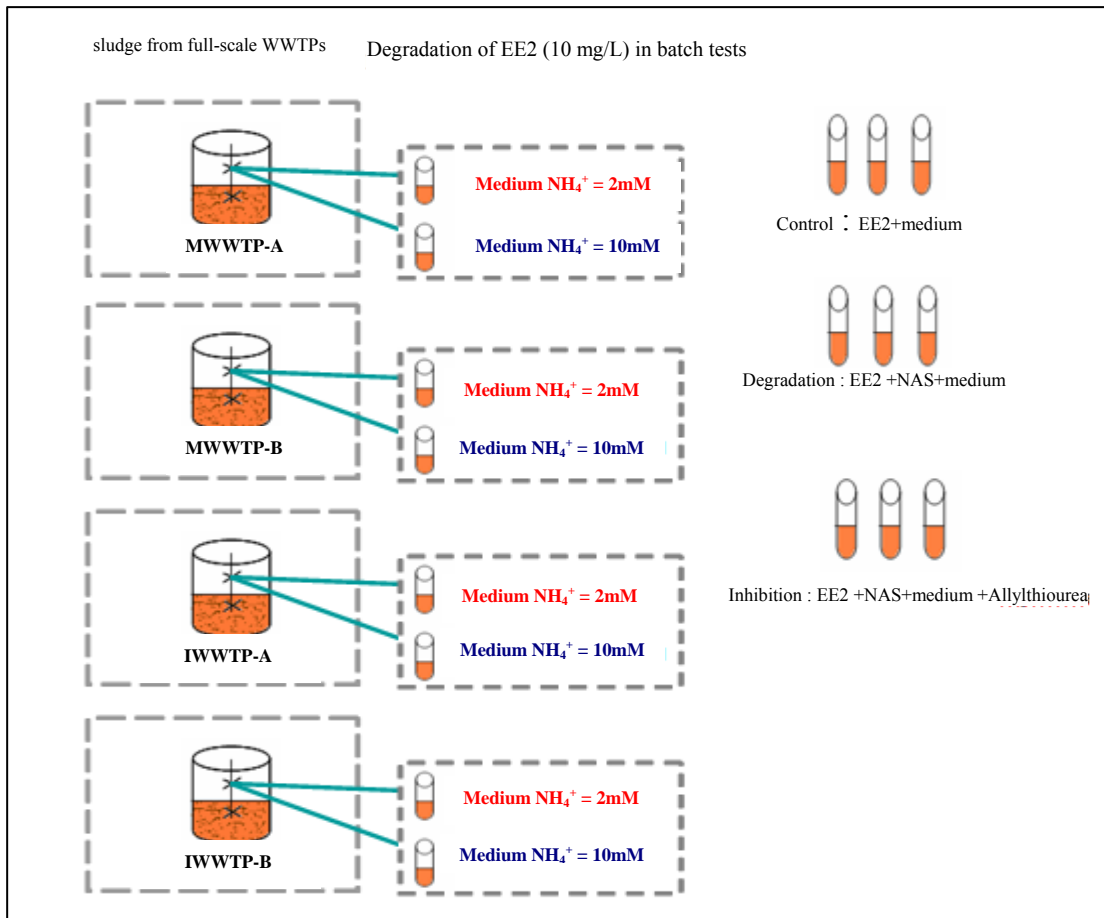


Figure 3.3 Degradation of EE2 by sludge from full-scale WWTPs containing different ammonia-oxidizing bacteria communities

## CHAPTER IV

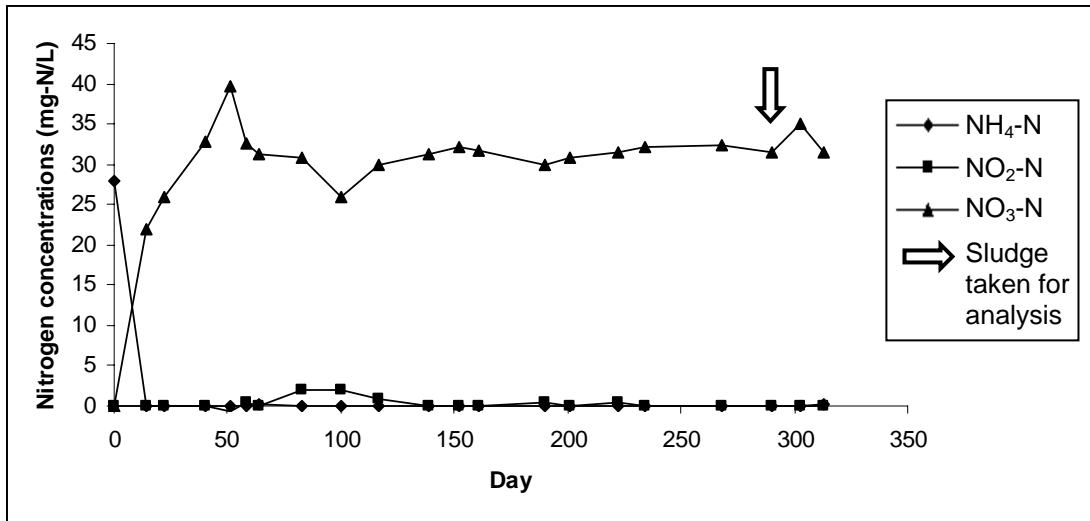
### RESULTS AND DISCUSSION

#### 4.1 Degradation of EE2 by enriched nitrifying activated sludge

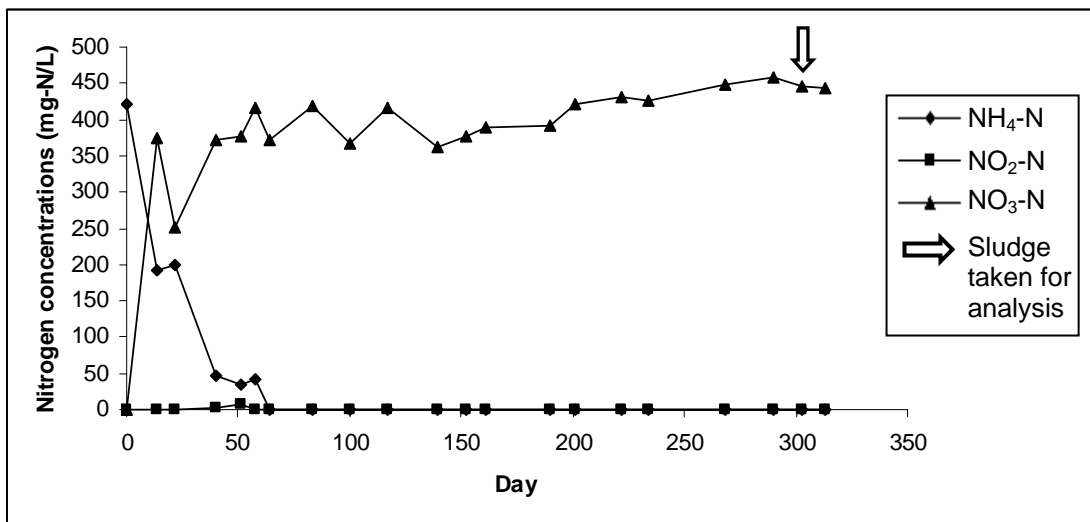
This experiment aimed to study the degradation patterns of EE2 by enriched NASs that contained different AOB communities. Sludge from a municipal WWTP was enriched in continuous-flow reactors receiving inorganic medium containing different ammonium concentrations of 2 and 30 mM. AOB with low affinity to ammonia such as those belonging to *Nitrosomonas oligotropha*, *Nitrosomonas communis* or *Nitrospira* cluster were expected to dominate in 2mM reactor while AOB with high affinity to ammonia such as those of *Nitrosomonas europaea*-*Nitrosococcus mobilis* cluster were thought to predominate in 30mM reactor. Then, these two enriched NASs were tested for their ability to degrade EE2 under different initial ammonium concentration of 2 and 10mM.

##### 4.1.1 Enrichment of nitrifying activated sludge by inorganic medium containing different ammonium concentrations of 2 and 30mM

This part of experiment aimed to enriched NASs containing different AOB communities. Sludge taken from a municipal WWTP was enriched in two continuous-flow reactors receiving inorganic medium containing different ammonium concentrations of 2 and 10mM. NASs were enriched for 10 months and during the operation, concentrations of nitrogens in both reactors were monitored as shown in Figure 4.1. Ammonium concentrations in 2 and 30mM reactors reached the steady state conditions in 14 and 64 days of operation, respectively. Nitrite accumulation was not observed and nitrate concentrations at equivalent levels to the supplied ammonium were observed after the reactors got into the steady state conditions. After both of the reactors were in steady state, NASs were taken for the analysis of AOB communities and tested for EE2 degradation patterns (290 and 303 days for 2 and 30mM reactors, respectively).



(a)



(b)

Figure 4.1 Concentrations of nitrogens during enrichment of nitrifying activated sludge of (a) 2 mM reactor and (b) 30 mM reactor

#### 4.1.2 Analysis of ammonia oxidizing bacterial communities in enriched nitrifying activated sludge

Communities of AOB in enriched NASs (2 and 30 mM reactors) were analyzed by specific PCR amplification, DGGE, and sequencing of bacterial 16S rRNA gene. All bands recovered from DGGE were cut, reamplified, and run on new gels until it was purified before selecting for sequencing. All bacterial 16S rRNA sequences were blasted by BLAST program. And then, the phylogenetic tree was constructed by ARB programs package. Detailed analysis can be found in Sontipan study. Table 4.1 summarizes AOB found in enriched NAS. Results suggested that a band analyzed from 2 mM reactor related to *Nitrosomonas oligotropha* cluster and that of the reactor 30 mM closely related to *N. europaea* cluster (Sonthipan et al., 2008).

Table 4.1 Summary of AOB found in enriched nitrifying activated sludge

AOB cluster	Reactor	
	2mM	30mM
<i>Nitrospira</i> cluster		
unknown <i>Nitrosomonas</i> cluster		
<i>Nitrosomonas cryototerans</i> cluster		
<i>Nitrosomonas europaea</i> - <i>Nitrosococcus mobilis</i> cluster		✓
<i>Nitrosomonas communis</i> cluster		
<i>Nitrosomonas marina</i> cluster		
<i>Nitrosomonas oligotropha</i> cluster	✓	

Symbol and Abbreviation: ✓, present

#### **4.1.3 Degradation patterns of EE2 by enriched NASs under different ammonium concentrations (2 and 10mM)**

Analysis of AOB communities demonstrated that AOB community in low ammonium level (2mM) reactor were different with that in high ammonia level (30mM) reactor. Therefore, enriched NASs were used to degrade EE2 at the different initial ammonia concentrations of 2 and 10mM. This experiment consisted of control test, inhibition test, and degradation test. Control test observed abiotic degradation of EE2 where no microorganisms were added. Inhibition test exhibited the degradation of EE2 by most microorganisms except for AOB. In this test, allylthiourea was added to inhibit AMO enzyme of AOB. Degradation test showed the degradation of EE2 by both heterotrops and AOB. Therefore, the different between degradation test and inhibition test were due to the degradation of EE2 by AOB.

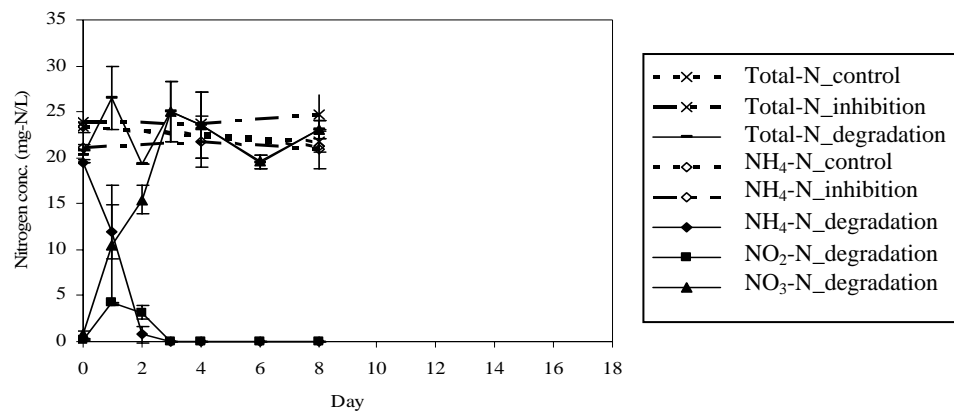
Results (Figure 4.2 (a) - 4.5 (a)) suggested that nitrogen concentrations in the control tests and inhibition tests changed insignificantly. These indicated that no abiotic ammonia oxidation occurred and AOB was inhibited completely by allylthiourea. In the degradation tests, ammonia was degraded completely (in 2 days for initial ammonium concentration of 2mM (2 and 30mM reactors), 11 and 8 days for initial ammonium concentration of 10mM (2 and 30mM reactors)). Nitrite concentrations were slightly increased from the first day and then reduced by changing to nitrate making increasing in nitrate concentrations. EE2 concentrations in all control tests were not reduced (Figure 4.2 (b) - 4.5 (b)) indicating that EE2 was not degraded abiotically. In the inhibition tests, EE2 concentrations slightly decreased in all tests suggesting that another microorganisms other than AOB degraded EE2. In the degradation tests, EE2 reduced corresponding to the ammonium oxidized. When ammonium oxidized completely, EE2 concentration became more stable but still decreased slowly. This may cause by some AMO enzyme remaining in the cells.

For NAS from 2mM reactor, the percent of EE2 degraded by AOB and heterotroph were 78.74 and 21.26%, respectively for the initial ammonium concentration 2mM and 63.34 and 36.66% for the initial ammonium concentration 10mM (Table 4.2). For NAS from 30mM reactor, the percent of EE2 degraded by AOB and heterotroph were 44.68 and 55.32%, respectively, for the initial ammonium concentration of 2mM and 57.66 and 42.34% for the initial ammonium concentration

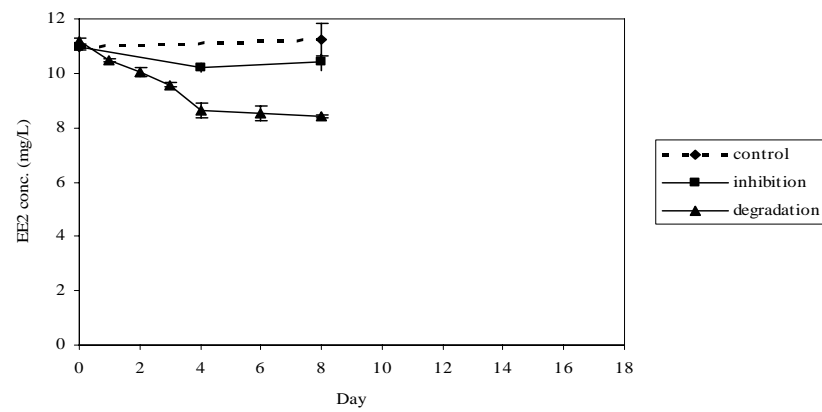
of 10mM. These results suggested that AOB was an important microorganisms degrading EE2 in 2mM reactor. However, in 30mM reactor, the role of heterotrophs must also be accounted.

For both NASs, although initial ammonium concentrations were varied resulting in increasing in the amounts of ammonium oxidized, the amounts of EE2 degraded seemed to be stable (comparing between initial ammonium concentrations of 2 and 10mM). These results showed clearly that EE2 degradation is independent from ammonia oxidation. This phenomena occurred probably by the fact that the amount of ammonium supplied in this study not yet limited (2mM) for the degradation of 10 mg/l EE2.

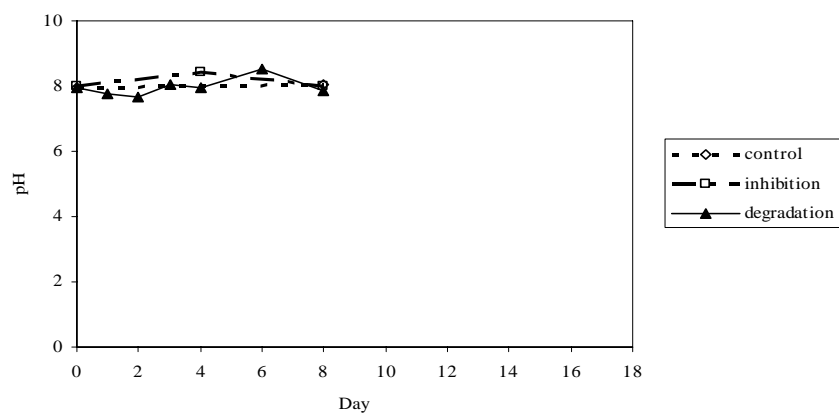
The ability of AOB to degrade EE2 can be considered by the ratio of EE2 degraded per ammonia oxidized ( $\text{mgEE2/gNH}_4^+$ ). For 2mM reactor, the ratios were 106.95 and 19.24  $\text{mgEE2/gNH}_4^+$  for initial ammonium concentration 2 and 10mM, respectively. And for 30mM reactor, they were 19.44 and 4.55  $\text{mgEE2/gNH}_4^+$  for initial ammonium concentration 2 and 10mM, respectively. With the same amount of ammonium degraded. This result suggested that NAS from 2mM reactor can degrade EE2 more than NAS from 30mM reactor. It must be noted that AOB communities in both reactors differed. AOB in 2mM reactor was a member of *Nitrosomonas* cluster while AOB in 30mM reactor was in *Nitrosomonas europaea* cluster. These results suggested that NASs with different AOB communities exhibited different degradation patterns of EE2. AOB with high affinity to ammonia (*Nitrosomonas* cluster) was able to degraded EE2 more than AOB with low affinity to ammonia (*Nitrosomonas europaea* cluster). Recently, Gaulke et al, 2008 discovered that pH below 7.0 have effect on abiotic degradation of EE2. Therefore, in this study, pH levels was monitored in all tests and results confirmed that the pH levels in all tests were above the effective level for the abiotic EE2 transformation (Figure 4.2 (c) and 4.3(c)).



(a)



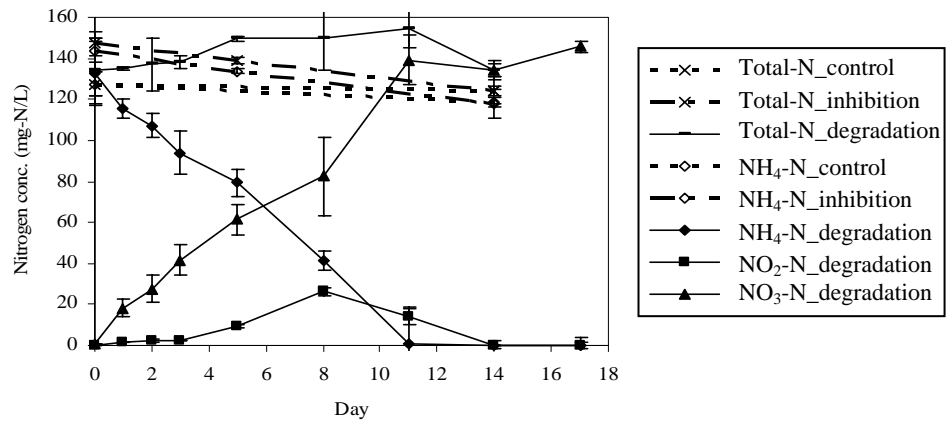
(b)



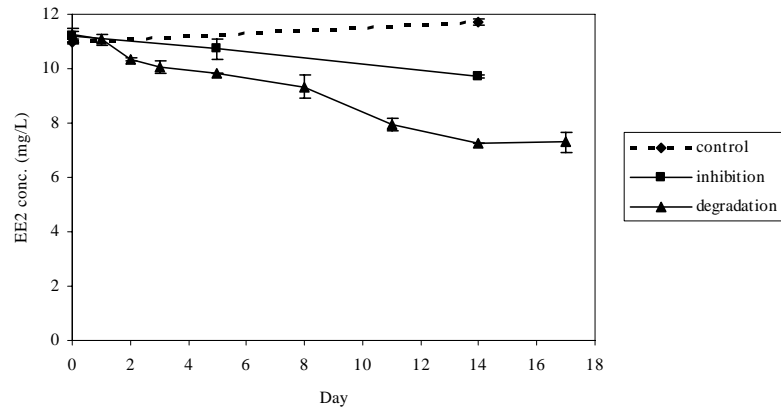
(c)

Figure 4.2 Degradation of EE2 by enriched nitrifying activated sludge from 2 mM reactor with initial ammonium concentrations of 2 mM : a) nitrogen concentrations, b) EE2 concentrations, and c) pH

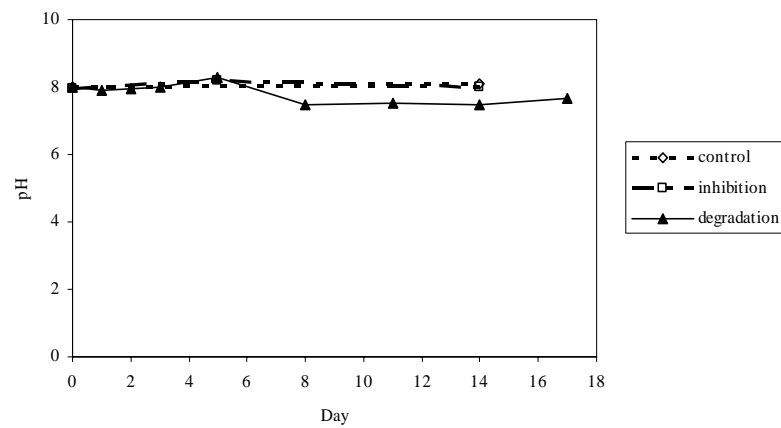




(a)

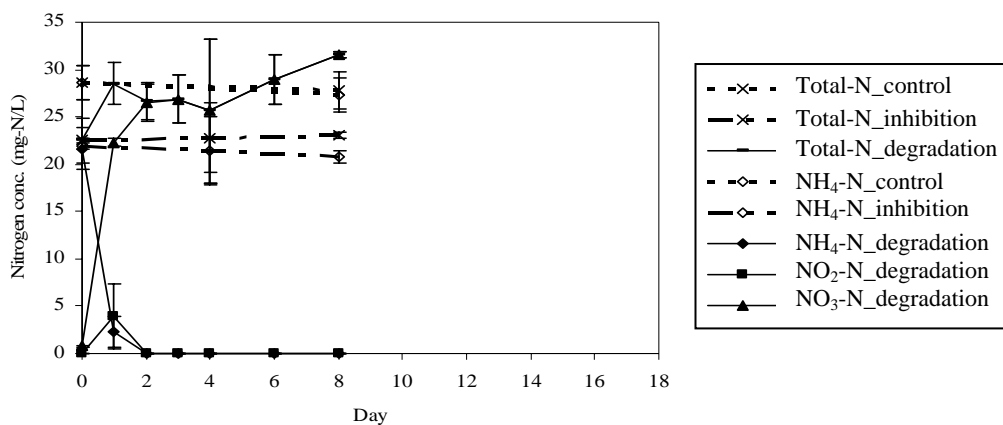


(b)

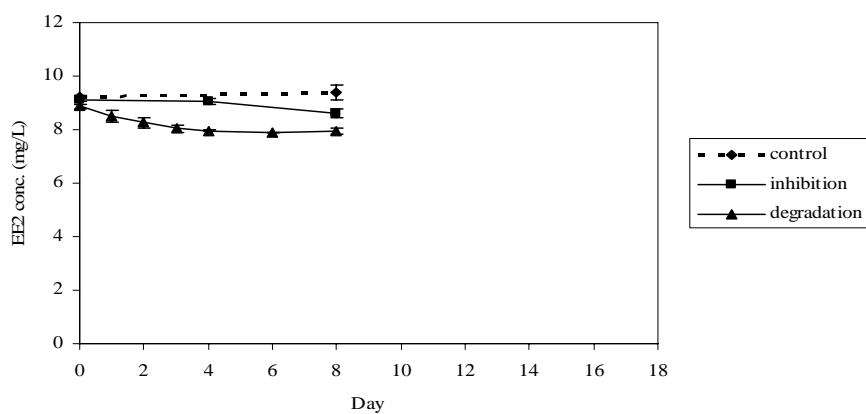


(c)

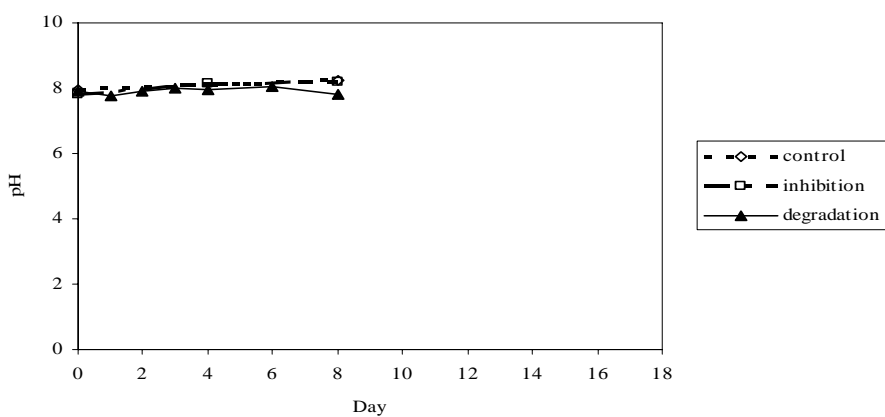
Figure 4.3 Degradation of EE2 by enriched nitrifying activated sludge from 2 mM reactor with initial ammonium concentrations of 10 mM : a) nitrogen concentrations, b) EE2 concentrations, and c) pH



(a)

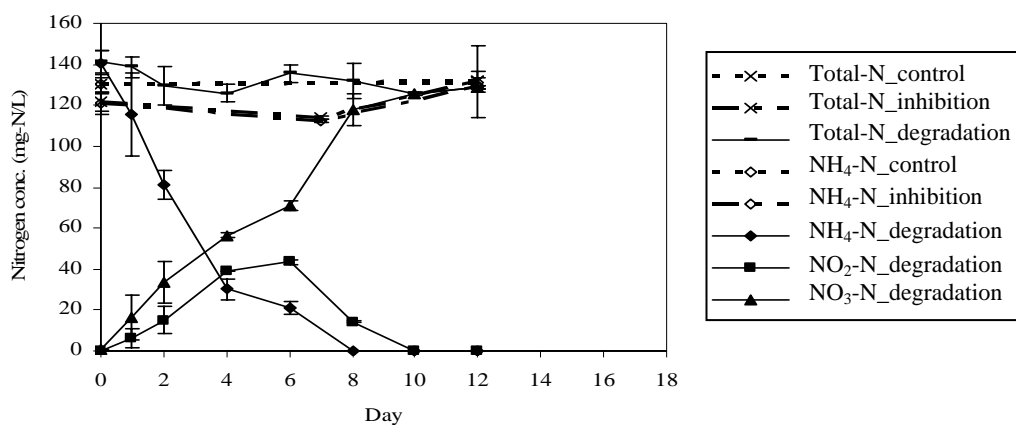


(b)

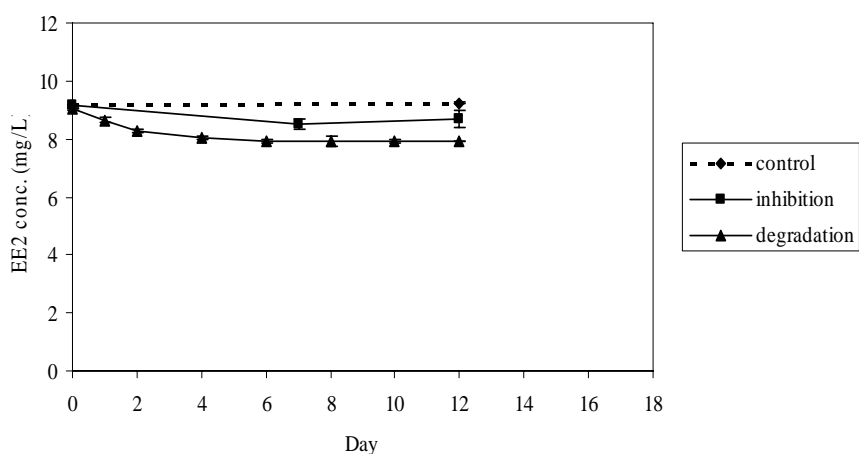


(c)

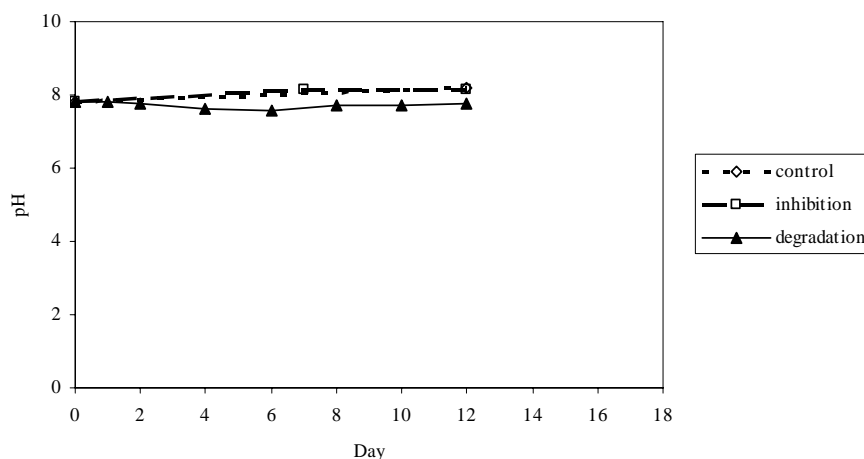
Figure 4.4 Degradation of EE2 by enriched nitrifying activated sludge from 30 mM reactor with initial ammonium concentrations of 2 mM : a) nitrogen concentrations, b) EE2 concentrations, and c) pH



(a)



(b)



(c)

Figure 4.5 Degradation of EE2 by enriched nitrifying activated sludge from 30 mM reactor with initial ammonium concentrations of 10 mM : a) nitrogen concentrations, b) EE2 concentrations, and c) pH

Table 4.2 Summarized values for degradation of EE2 by enriched nitrifying activated sludge

NAS (mM reactor)	Initial NH <sub>4</sub> conc. (mM)	Ammonium oxidized (g)	EE2 degraded (mg)			EE2 degraded (%)			hours	Ammonium rate		EE2 rate			EE2:ammonium (AOB)	
			overall	AOB	Heterotrophs	overall	AOB	Heterotrophs		K (1/hr)	mg/hr	K (1/hr)	AOB (mg/hr)	Heterotrophs (mg/hr)	mgEE2 /gNH <sub>4</sub>	mgEE2/ gNH <sub>4</sub> /hr
2	2	0.02	2.54	2.00	0.54	22.74	78.74	21.26	96	-0.0025	0.19	-0.0880	0.0208	0.0056	106.95	1.11
	10	0.13	4.01	2.54	1.47	35.61	63.34	36.66	336	-0.0253	0.39	-0.0013	0.0076	0.0044	19.24	0.06
30	2	0.02	0.94	0.42	0.52	10.56	44.68	55.32	96	-0.0717	0.23	-0.0012	0.0044	0.0054	19.44	0.20
	10	0.14	1.11	0.64	0.47	12.31	57.66	42.34	192	-0.0332	0.73	-0.0006	0.0033	0.0024	4.55	0.02

## **4.2 Degradation of EE2 by sludge from full-scale wastewater treatment plants**

This experiment aimed to study degradation patterns of EE2 by sludge from full-scale WWTPs that contained different AOB communities. Sludge were taken from four full-scale WWTPs that received wastewater containing different levels of ammonium. Then the sludge from four full-scale WWTPs were tested for their ability to degrade EE2 under initial ammonium concentrations of 2 and 10mM.

### **4.2.1 Collection of sludge from full-scale wastewater treatment plants**

Four sludge were taken from two municipal WWTPs (MWWTP-A and MWWTP-B) to represent low ammonium load system and two industrial WWTPs (IWWTP-A and IWWTP-B) to represent high ammonium load system. The influent ammonium concentrations of MWWTP-A and MWWTP-B were 13.87 and 8.11 mg-N/L, respectively, while the influent ammonium concentrations of IWWTP-A and IWWTP-B were 422.26 and 77.11 mg-N/L, respectively. Detailed characteristics of WWTPs were described in Table 4.3.

Table 4.3 Detailed characteristics of full-scale wastewater treatment plants

Type	WWTP	System configuration	Wastewater flow (m <sup>3</sup> /day)	MLSS in AS reactor (mg/l)	Influent nitrogen concentrations				Effluent nitrogen concentrations			
					BOD	[NH <sub>4</sub> ] (mg-N/L)	[NO <sub>2</sub> ] (mg-N/L)	[NO <sub>3</sub> ] (mg-N/L)	BOD	[NH <sub>4</sub> ] (mg-N/L)	[NO <sub>2</sub> ] (mg-N/L)	[NO <sub>3</sub> ] (mg-N/L)
Municipal	MWWTP-A	Activated sludge	2,000,000	6,000	102.00	13.87	0.01	2.27	2.00	0.00	0.02	18.15
	MWWTP-B	Activated Sludge (CASS)	2,000,000	NA	27.31	8.11	0.02	0.81	7.04	4.22	0.33	3.95
Industrial	IWWTP-A (Food industry)	Activated Sludge	5,000	4,000	1,400	422.26	0.04	3.24	7.00	29.19	0.22	31.05
	IWWTP-B (Slaughterhouse)	Activated Sludge	2,500	6,600	NA	77.11	0.02	3.61	NA	7.54	0.08	0.38

Symbol and Abbreviation: MLSS, mixed liquor suspended solids and NA, not available

#### 4.2.2 Analysis of ammonia-oxidizing bacterial communities in sludge from full-scale wastewater treatment plants

Communities of AOB in sludge from full-scale WWTPs were analyzed by specific PCR amplification, DGGE, and sequencing of bacterial 16S rRNA gene. All bands recovered from DGGE were cut, reamplified, and run on new gels until it was purified before selecting for sequencing. All bacterial 16S rRNA sequences were blasted by BLAST program. Then, the phylogenetic tree was constructed by ARB programs package. Table 4.4 summarized AOB found in sludge from WWTPs. Bands analyzed for MWWTP-A related to *Nitrosomonas communis* cluster. AOB in MWWTP-B was found to closely relate to *Nitrosomonas communis* cluster and *Nitrosomonas oligotropha* cluster. AOB in IWWTP-A was found to be a member of *Nitrosomonas europaea-Nitrosomonas mobilis* cluster. And AOB of *Nitrosomonas communis* cluster was found in IWWTP-B (Sonthipan et al., 2008).

Table 4.4 Summary of AOB found in sludge from full-scale wastewater treatment plants

AOB cluster	Wastewater treatment plants			
	MWWTP-A	MWWTP-B	IWWTP-A	IWWTP-B
<i>Nitrospira</i> cluster				
unknown <i>Nitrosomonas</i> cluster				✓
<i>Nitrosomonas cryototerans</i> cluster				
<i>Nitrosomonas europaea-Nitrosococcus mobilis</i> cluster			✓	
<i>Nitrosomonas communis</i> cluster	✓	✓		✓
<i>Nitrosomonas marina</i> cluster				
<i>Nitrosomonas oligotropha</i> cluster		✓		

Symbol and Abbreviation: ✓, present

### 4.2.3 Degradation patterns of EE2 by sludge from full-scale WWTPs under different ammonium concentrations (2 and 10mM)

Analysis of AOB communities demonstrated that AOB communities in sludge from municipal WWTPs varied significantly. Sludge was used to degrade EE2 at the different initial ammonia concentrations of 2 and 10mM. This experiment consisted of control test, inhibition test, and degradation test. Control test observed abiotic degradation of EE2 where no microorganisms were added. Inhibition test exhibited the degradation of EE2 by most microorganisms except for AOB. In this test, Allylthiourea was added to inhibit AMO enzyme of AOB. Degradation test showed the degradation of EE2 by both heterotrophs and AOB. Therefore, the difference between degradation test and inhibition test were due to the degradation of EE2 by AOB.

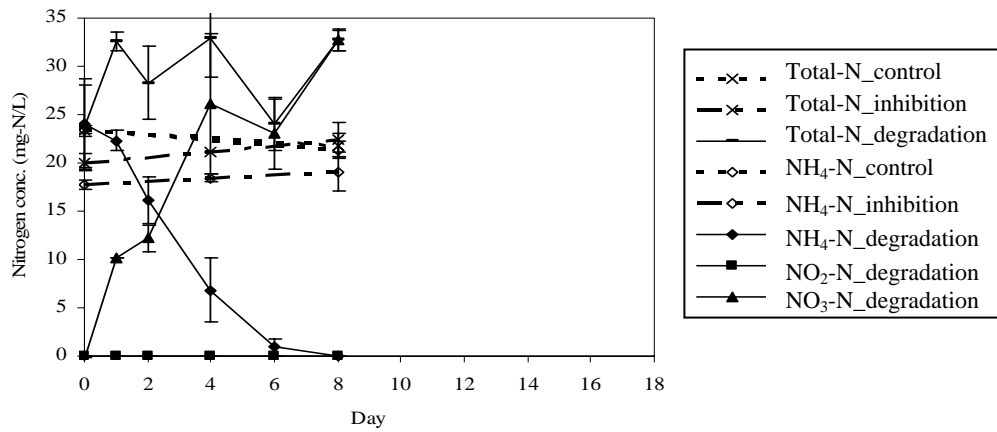
Results (Figure 4.6 (a) - 4.13(a)) suggested that nitrogen concentrations in the control tests and the inhibition tests changed insignificantly. These indicated that no abiotic ammonia oxidation occurred and AOB was inhibited completely by allylthiourea. In the degradation tests, ammonium was degraded completely in 8, 4, 3, and 4 days for initial ammonium concentration 2mM (MWWTP-A, MWWTP-B, IWWTP-A, and IWWTP-B respectively); 11, 16, 14, and 12 days for initial ammonium concentration 10mM (MWWTP-A, MWWTP-B, IWWTP-A, and IWWTP-B respectively). Nitrite concentrations were increased little from the first day and then reduced by changing to nitrate making the increase in nitrate concentrations. EE2 concentrations in all control tests were not reduced (Figure 4.6 (b) - 4.13(b)). This indicated that EE2 was not abiotically degraded. In all inhibition tests, EE2 concentrations decreased suggesting that another microorganisms other than AOB degraded EE2. In the degradation tests, EE2 reduced corresponding to the ammonium oxidized. When ammonium oxidized completely, EE2 concentration became more stable but still decreased slowly. This may be caused by some AMO enzyme remaining in the cells. For NAS from MWWTP-A, the percent of EE2 degraded by AOB and heterotrophs were 59.39 and 40.61%, respectively, for initial ammonium concentration of 2mM and 73.56 and 26.44% for initial ammonium concentration of 10mM (Table 4.5). For NAS from MWWTP-B, the percent of EE2 degraded by AOB and heterotrophs were 67.06 and 32.94%, respectively, for initial ammonium



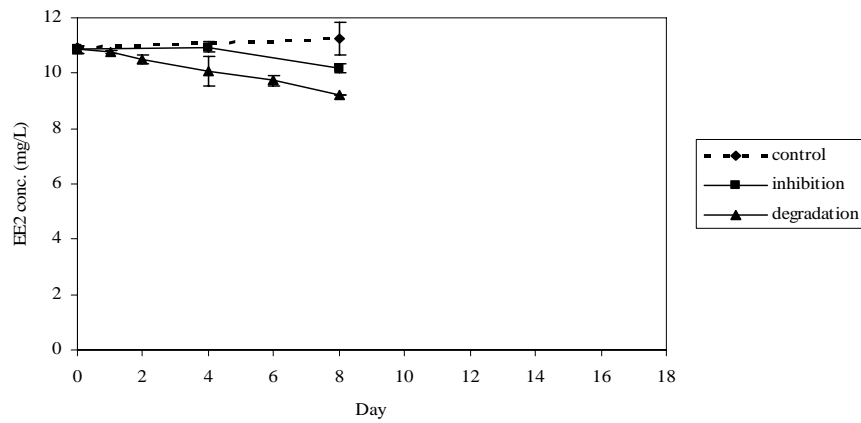
concentration 2mM and 73.91 and 26.09% for initial ammonium concentration 10mM. For NAS from IWWTP-A, the percent of EE2 degraded by AOB and heterotrophs were 10.06 and 89.94%, respectively, for initial ammonium concentration of 2mM and 72.27 and 27.73% for initial ammonium concentration of 10mM. In addition, NAS from IWWTP-B, the percent of EE2 degraded by AOB and heterotrophs were 24.27 and 75.73%, respectively, for initial ammonium concentration 2mM and 47.37 and 52.63% for initial ammonium concentration 10mM. These results showed that in municipal sludge (MWWTP-A and MWWTP-B) AOB played a major role in EE2 degradation while small amounts of EE2 were degraded by heterotrophs. In addition, in the municipal sludge, the role of AOB increased when more ammonium was supplied (comparing between initial ammonium concentrations of 2 and 10mM). In the case of industrial sludge, heterotrophs were the one that degraded EE2 considerably. However, when more ammonium was supplied, the role of AOB increased significantly, especially in case of IWWTP-A. This may cause by the fact that AOB from this plant get used to high ammonium level. They may lost some activity at low ammonium level of 2mM. However, when ammonium level increased to 10mM, they can be more active.

The ability of AOB to degrade EE2 can be considered by the ratio of EE2 degraded per ammonium oxidized (mgEE2/gNH<sub>4</sub><sup>+</sup>). For MWWTP-A, the ratios were 42.35 and 25.48 mgEE2/gNH<sub>4</sub><sup>+</sup> for initial ammonium concentration 2 and 10mM, respectively. And for MWWTP-B, they were 23.71 and 8.27 mgEE2/gNH<sub>4</sub><sup>+</sup> for initial ammonium concentration 2 and 10mM, respectively. For IWWTP-A, the ratios were 7.61 and 22.21 mgEE2/gNH<sub>4</sub><sup>+</sup> for initial ammonium concentration 2 and 10mM, respectively. And for IWWTP-B they were 10.90 and 2.74 mgEE2/gNH<sub>4</sub><sup>+</sup> for initial ammonium concentration 2 and 10mM, respectively. These results suggested that NASs from municipal WWTSs can degrade EE2 more than NASs from industrial WWTSs and amount industrial sludge, IWWTP-B degraded EE2 better than IWWTP-A. AOB communities among the sludge varied (*Nitrosomonas communis* cluster in MWWTP-A, *Nitrosomonas communis* cluster and *Nitrosomonas oligotropha* cluster in MWWTP-B, *Nitrosomonas europaea*-*Nitrosomonas mobilis* cluster in IWWTP-A, and Unknown *Nitrosomonas* cluster and *Nitrosomonas communis* cluster in IWWTP-B).

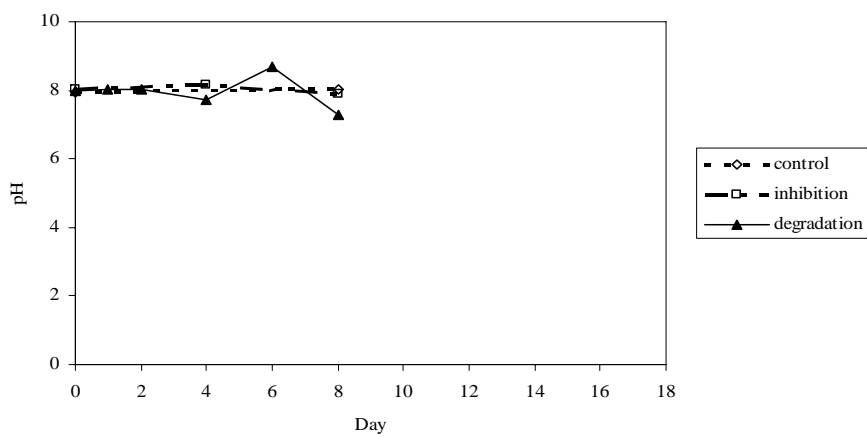
The result suggested that NASs with different AOB communities exhibited different degradation patterns of EE2. AOB with high affinity to ammonia (Unknown *Nitrosomonas* cluster, *Nitrosomonas communis* cluster and *Nitrosomonas oligotropha* cluster, MWWTP-A, MWWTP-B, IWWTP-B) was able to degrade EE2 more than AOB with low affinity to ammonia (*Nitrosomonas europaea*-*Nitrosomonas mobilis* cluster, IWWTP-A) at low ammonium concentration. pH levels was monitored during the all tests and results confirmed that the pH levels in all tests were above the effective level for the abiotic EE2 transformation (Figure 4.6 (c) and 4.13(c)).



(a)

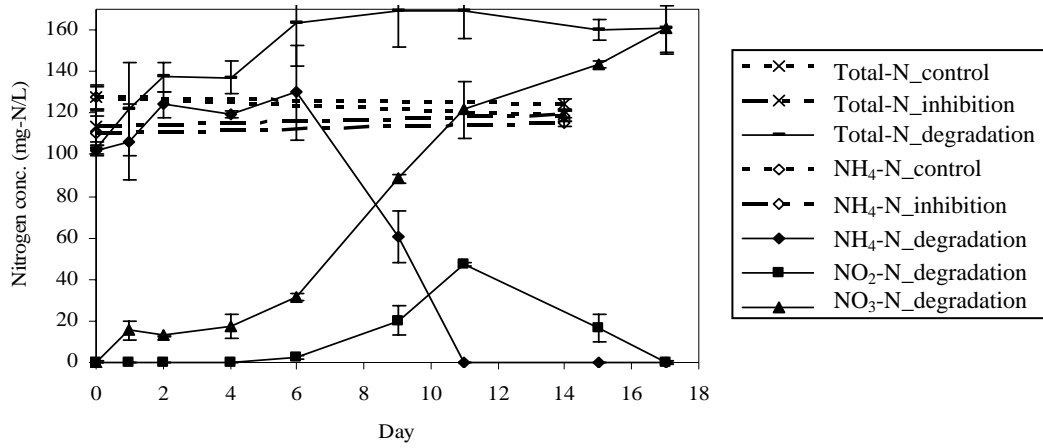


(b)

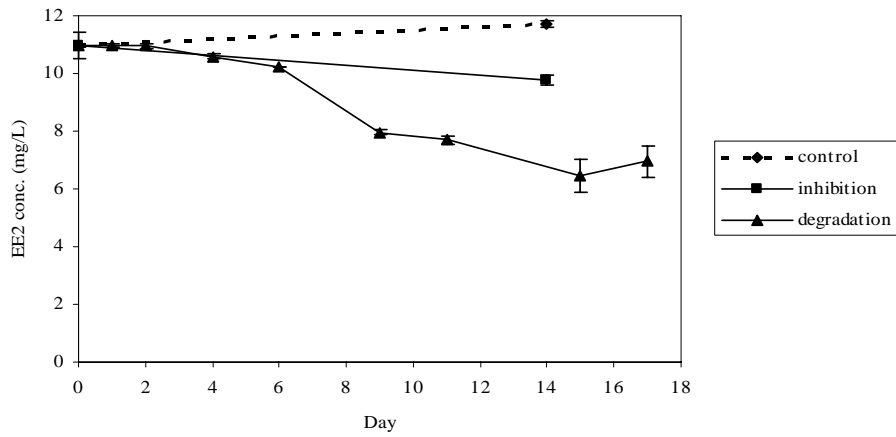


(c)

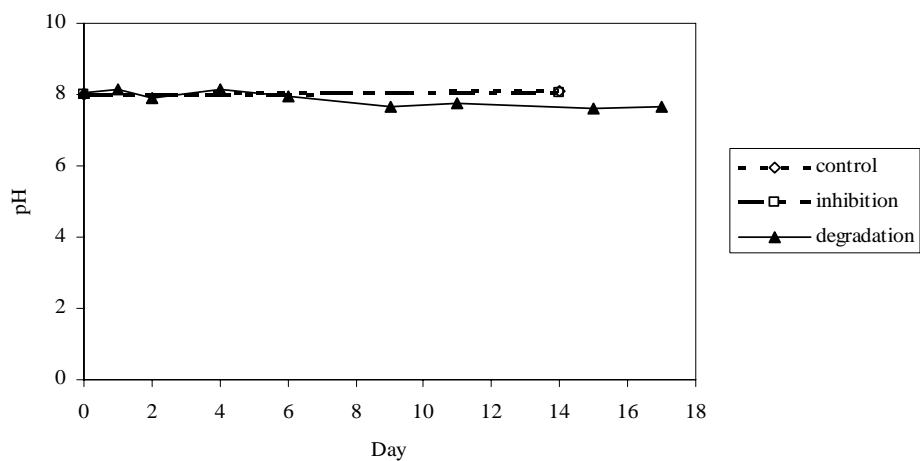
Figure 4.6 Degradation of EE2 by sludge from MWWTP-A with initial ammonium concentrations of 2 mM : a) nitrogen concentrations, b) EE2 concentrations, and c) pH



(a)

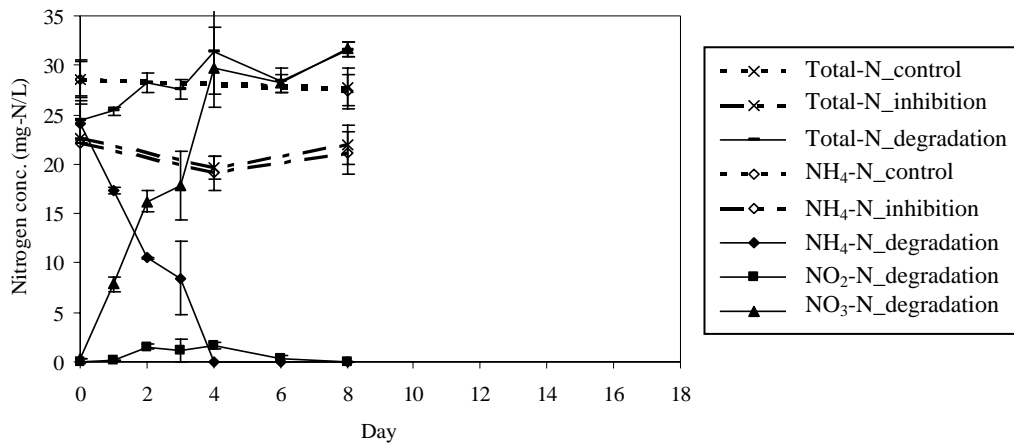


(b)

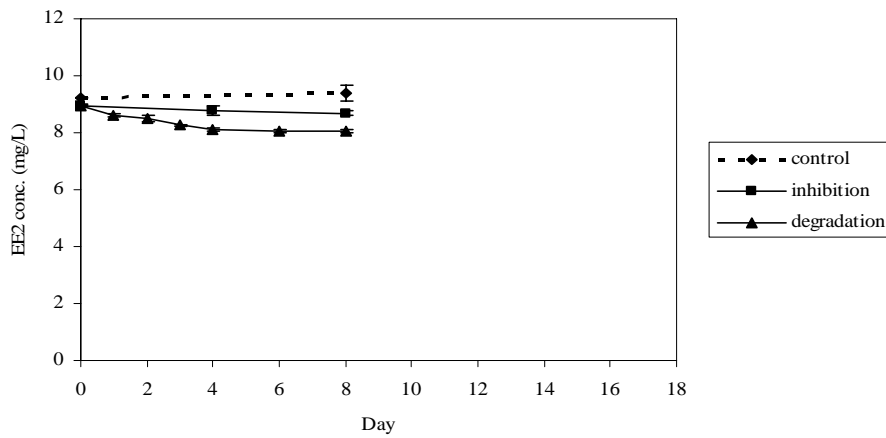


(c)

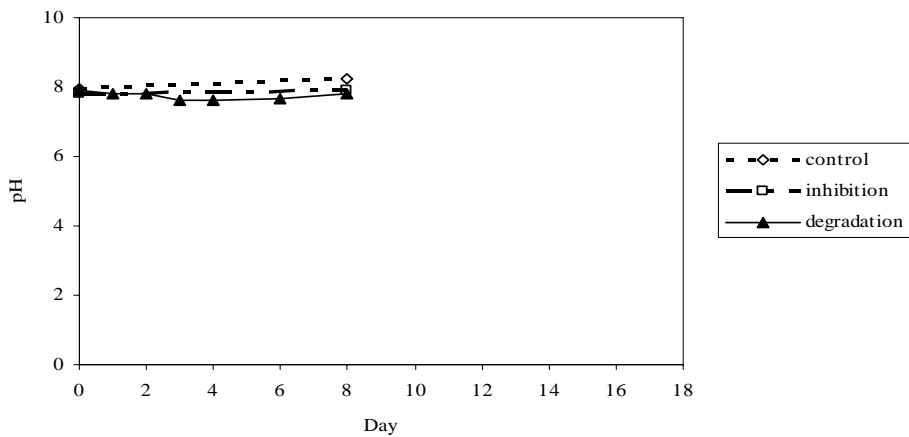
Figure 4.7 Degradation of EE2 by sludge from MWWTP-A with initial ammonium concentrations of 10 mM : a) nitrogen concentrations, b) EE2 concentrations, and c) pH



(a)

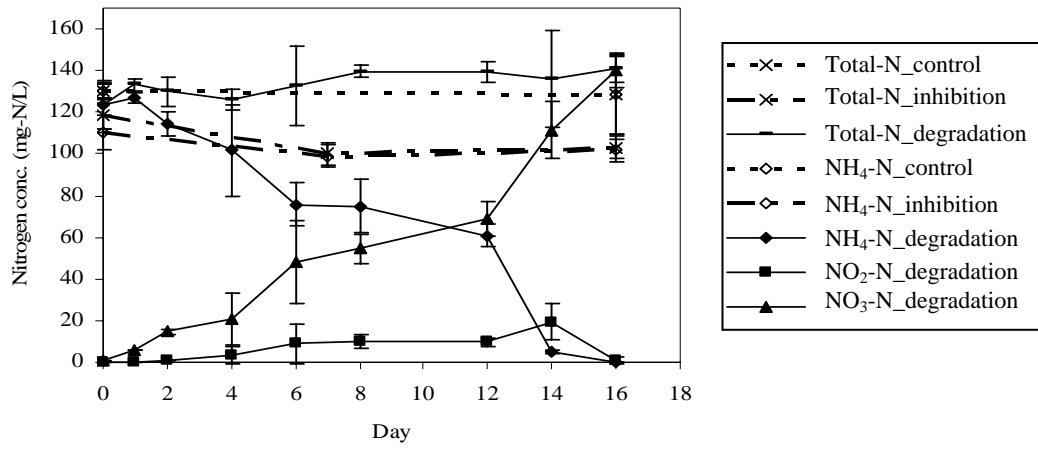


(b)

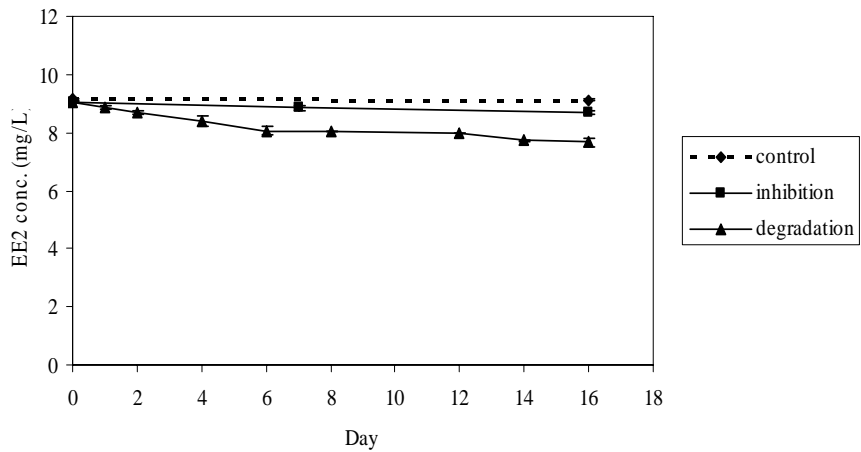


(c)

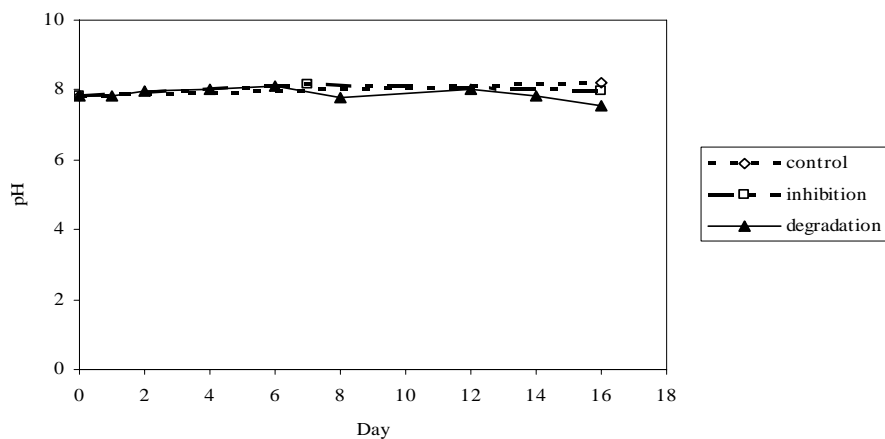
Figure 4.8 Degradation of EE2 by sludge from MWWTP-B with initial ammonium concentrations of 2 mM : a) nitrogen concentrations, b) EE2 concentrations, and c) pH



(a)

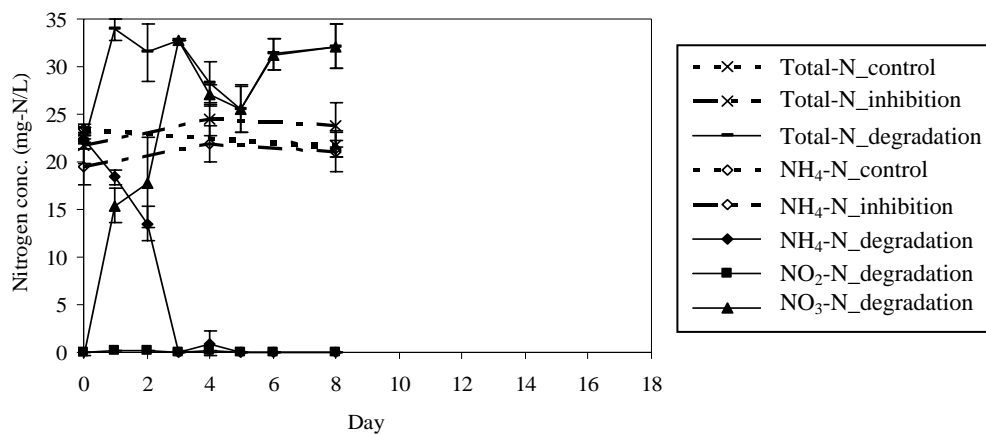


(b)

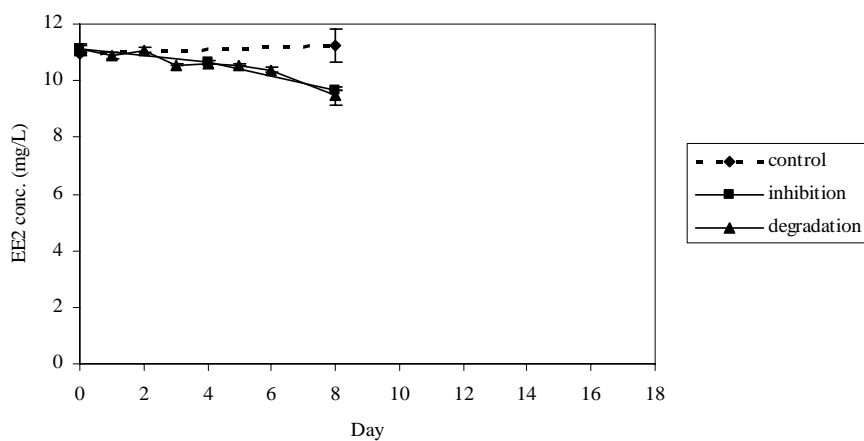


(c)

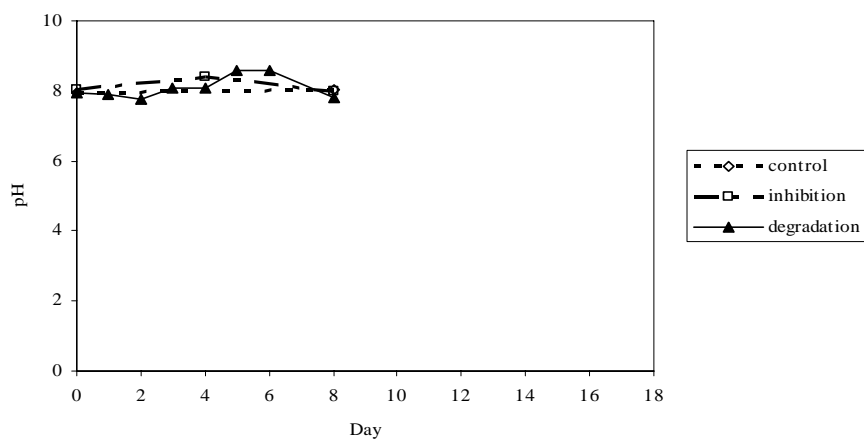
Figure 4.9 Degradation of EE2 by sludge from MWWTP-B with initial ammonium concentrations of 10 mM : a) nitrogen concentrations, b) EE2 concentrations, and c) pH



(a)

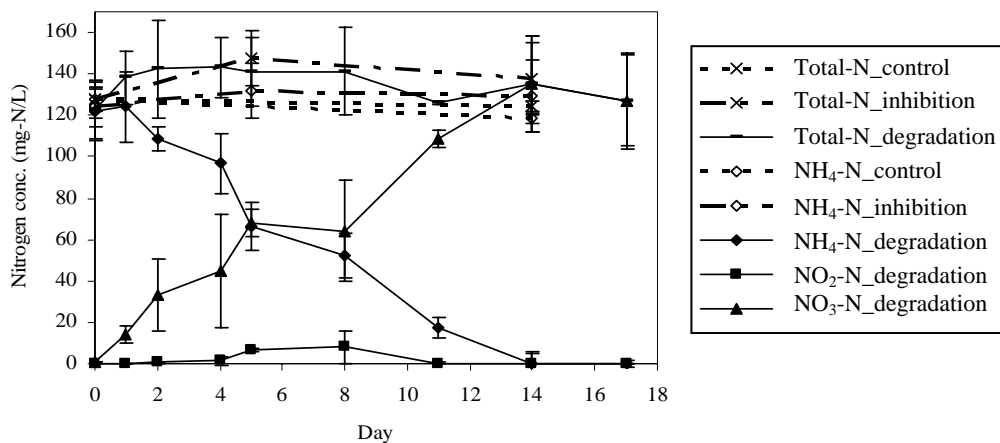


(b)

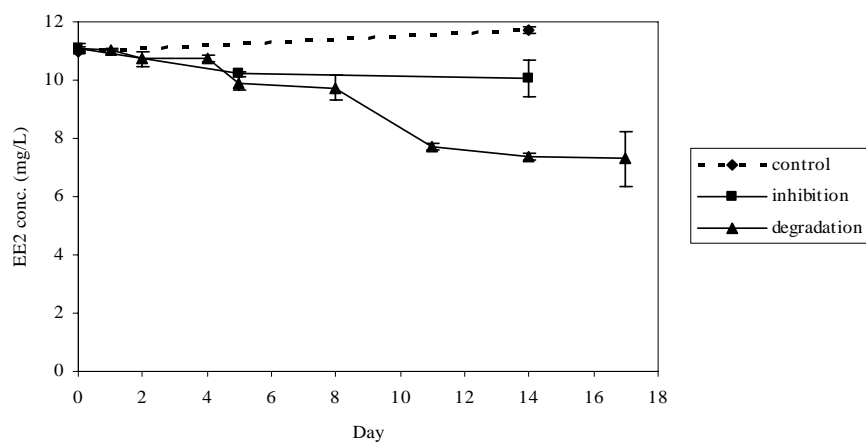


(c)

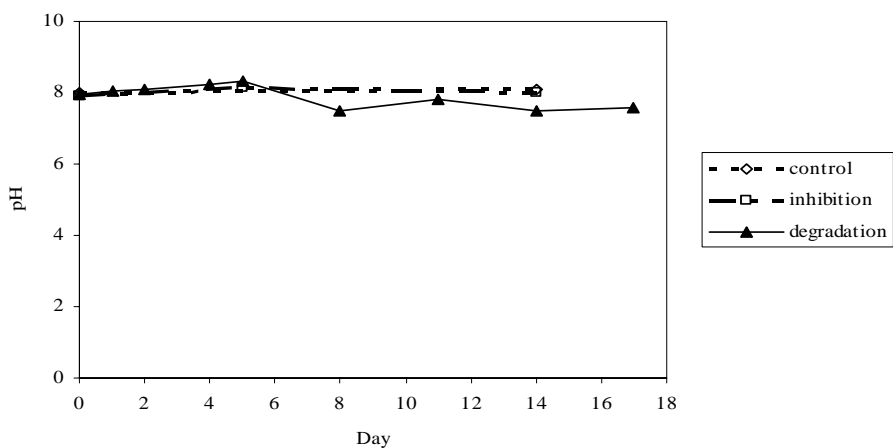
Figure 4.10 Degradation of EE2 by sludge from IWWTP-A with initial ammonium concentrations of 2 mM : a) nitrogen concentrations, b) EE2 concentrations, and c) pH



(a)



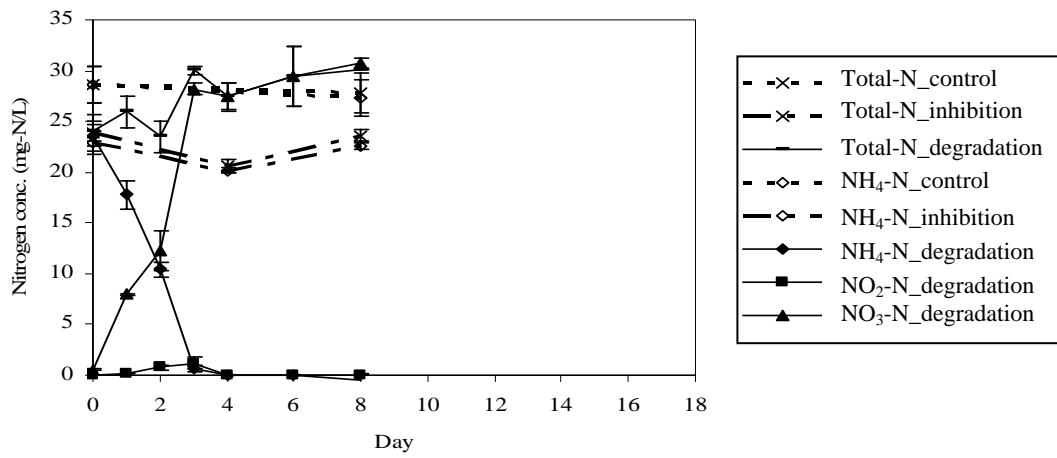
(b)



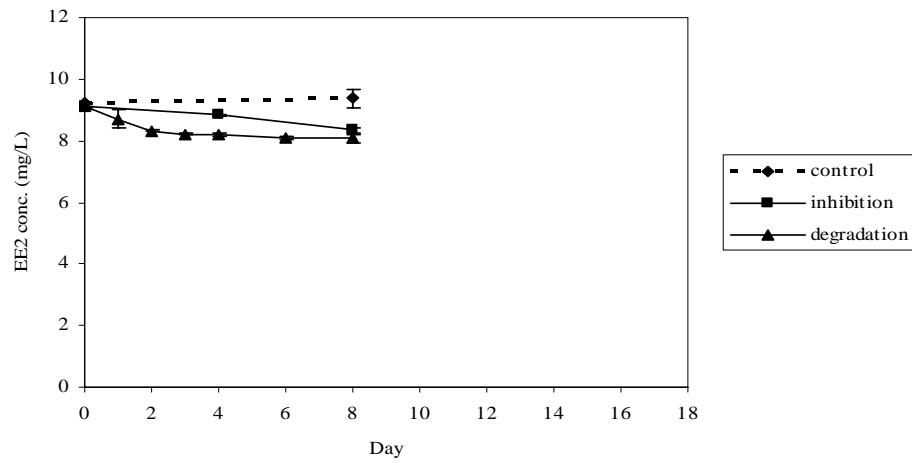
(c)

Figure 4.11 Degradation of EE2 by sludge from IWWTP-A with initial ammonium concentrations of 10 mM : a) nitrogen concentrations, b) EE2 concentrations, and c) pH

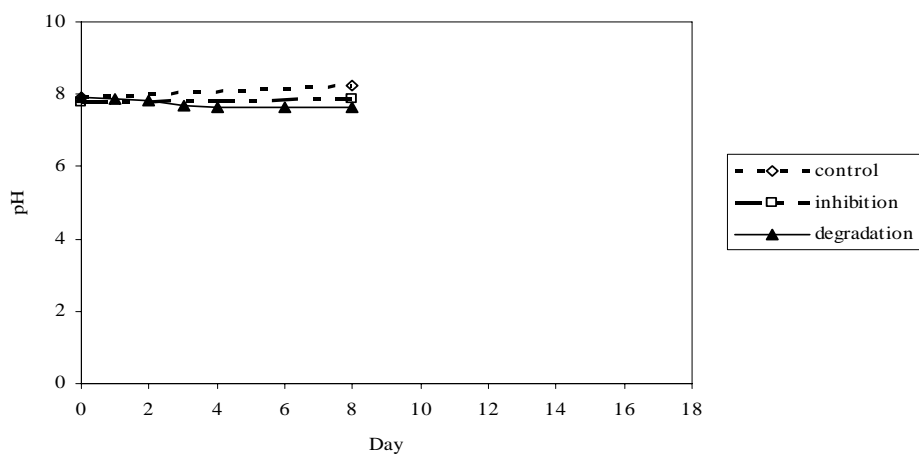




(a)

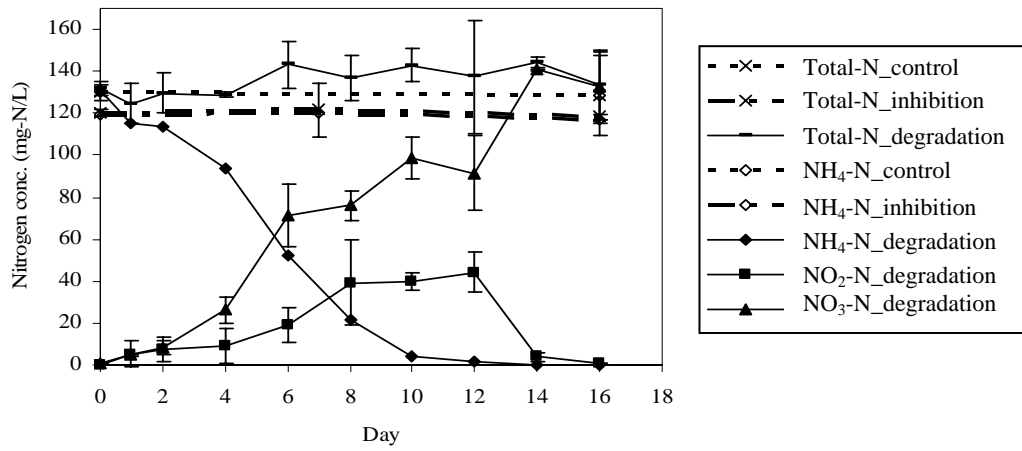


(b)

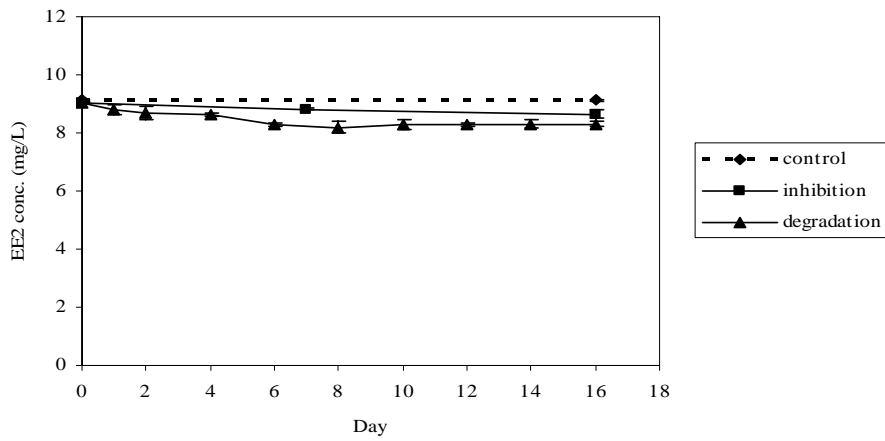


(c)

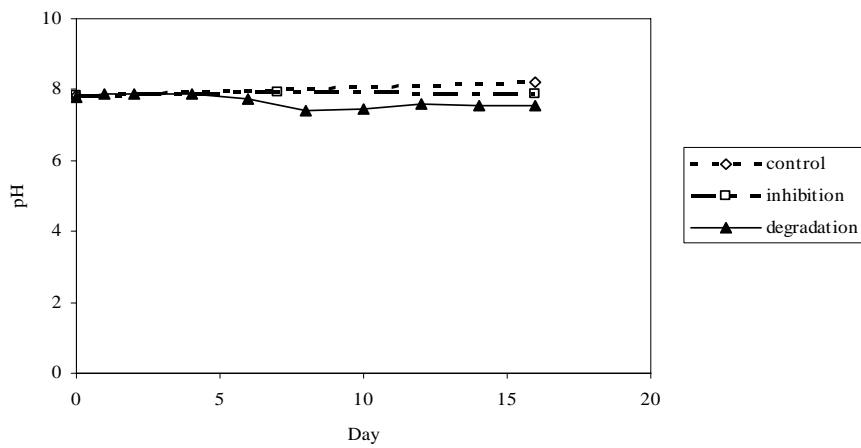
Figure 4.12 Degradation of EE2 by sludge from IWWTP-B with initial ammonium concentrations of 2 mM : a) nitrogen concentrations, b) EE2 concentrations, and c) pH



(a)



(b)



(c)

Figure 4.13 Degradation of EE2 by sludge from IWWTP-B with initial ammonium concentrations of 10 mM : a) nitrogen concentrations, b) EE2 concentrations, and c) pH

Table 4.5 Summarized values for degradation of EE2 by sludge from full-scale WWTPs

WWTS	Initial NH <sub>4</sub> conc. (mM)	Ammonium oxidized (g)	EE2 degraded (mg)			EE2 degraded (%)			hours	Ammonium rate		EE2 rate			EE2:ammonium (AOB)	
			overall	AOB	Heterotrophs	overall	AOB	Heterotrophs		K (1/hr)	mg/hr	K (1/hr)	AOB (mg/hr)	Heterotrophs (mg/hr)	mgEE2/gNH <sub>4</sub>	mgEE2/gNH <sub>4</sub> /hr
MWWTP-A	2	0.02	1.65	0.98	0.67	15.21	59.39	40.61	192	-0.0222	0.1205	-0.0009	0.0054	0.0035	42.35	0.22
	10	0.13	4.50	3.31	1.19	41.02	73.56	26.44	408	-0.0019	0.3184	-0.0014	0.0082	0.0029	25.48	0.06
MWWTP-B	2	0.02	0.85	0.57	0.28	9.48	67.06	32.94	192	-0.0151	0.1254	-0.0008	0.0031	0.0015	23.67	0.12
	10	0.12	1.38	1.02	0.36	15.27	73.91	26.09	384	-0.0070	0.3211	-0.0004	0.0024	0.0009	8.27	0.02
IWWTP-A	2	0.02	1.69	0.17	1.52	15.17	10.06	89.94	192	-0.0587	0.1164	-0.0008	0.0020	0.0072	7.61	0.07
	10	0.12	3.75	2.71	1.04	33.78	72.27	27.73	336	-0.0051	0.3632	-0.0009	0.0074	0.0034	22.21	0.08
IWWTP-B	2	0.02	1.03	0.25	0.78	11.29	24.27	75.73	144	-0.0473	0.1592	-0.0008	0.0016	0.0054	10.90	0.01
	10	0.13	0.76	0.36	0.40	8.40	47.37	52.63	336	-0.0194	0.3905	-0.0002	0.0009	0.0013	2.74	0.01

#### **4.3 Degradation of EE2 by enriched nitrifying activated sludge and sludge from full-scale wastewater treatment plants.**

Both studies (enriched NASs and sludge from full-scale WWTPs) showed similar results. AOB communities with high affinity to ammonia degraded EE2 better than AOB communities with low affinity to ammonia.

## CHAPTER V

### CONCLUSIONS AND SUGGESTIONS FOR FUTURE WORK

#### 5.1 Conclusions

This study investigated the degradation of EE2 by enriched NAS and sludge from full-scale wastewater treatment plants (WWTPs) that contained different AOB communities. The findings of this study fulfill all the objectives. Significant details of the findings can be summarized as follow.

AOB communities in enriched NASs from 2 and 30 mM reactors differed significantly. AOB in 2 mM reactor related to *Nitrosomonas oligotropha* cluster and AOB in 30 mM reactor closely related to *Nitrosomonas europaea* cluster. NASs from both reactors exhibited different degradation patterns of EE2. NAS containing AOB with high affinity to ammonia (*Nitrosomonas oligotropha* cluster) was able to degrade EE2 more than that with low affinity to ammonia (*Nitrosomonas europaea* cluster). In addition, although the initial ammonium concentrations were varied resulting in increasing in the amounts of ammonium oxidized, the amounts of EE2 degraded seemed to be stable (comparing between initial ammonium concentrations of 2 and 10mM). This suggested that EE2 degradation is a result of ammonia oxidation but independent from the initial ammonium concentrations and thus the amounts of ammonia oxidized.

Four sludges were taken from two municipal WWTPs (MWWTP-A and MWWTP-B) to represent low ammonium load systems and two industrial WWTPs (IWWTP-A and IWWTP-B) to represent high ammonium load systems. Communities of AOB in MWWTP-A related to *Nitrosomonas communis* cluster, MWWTP-B related to *Nitrosomonas communis* cluster and *Nitrosomonas oligotropha* cluster, IWWTP-A related to *Nitrosomonas europaea-Nitrosomonas mobilis* cluster, and IWWTP-B related to *Nitrosomonas communis* cluster. In municipal sludge (MWWTP-A and MWWTP-B) AOB played a major role in EE2 degradation while

small amounts of EE2 were degraded by heterotrophs. In contrast, in industrial sludge, heterotrophs were the one that degraded EE2 considerably. However, when more ammonium was supplied, the role of AOB increased significantly, especially in case of IWWTP-A. This may be caused by the fact that AOB from this plant get used to high ammonium level. They may lose some activity at low ammonium level of 2mM. However, when ammonium level increased to 10 mM, they can be more active.

Results tended to show that NAS or sludge with different AOB communities exhibited different degradation patterns of EE2. AOB with high affinity to ammonia (Unknown *Nitrosomonas* cluster, *Nitrosomonas communis* cluster and *Nitrosomonas oligotropha* cluster MWWTP-A, MWWTP-B, IWWTP-B) was able to degrade more EE2 than AOB with low affinity to ammonia (*Nitrosomonas europaea*-*Nitrosomonas mobilis* cluster, IWWTP-A). However, it is hard to say this conclusion exactly as heterotrophs also played significant role in sludge from full-scale WWTPs and can not be neglected.

## 5.2 Suggestions for future works

There are several points that should be studied in more details; most important point is whether different AOB species degraded EE2 differently. This can be done by studying the degradation patterns of EE2 by different AOB pure cultures and study mechanisms of metabolism and co-metabolism of AOB in terms of enzyme induction, enzyme expression, and enzyme activity. Also, the similar approach can be applied for the degradation of other recalcitrant pollutants existing in municipal wastewater by AOB via co-metabolism.

## REFERENCES

- American Public Health Association. Standard methods for the examination of water and wastewater, 20<sup>th</sup> edition, Washington D.C., USA, 1998
- Arciero, D. T., Vannelli, M. L., and Hooper, A. B. Degradation of trichloroethylene by the ammonia-oxidizing bacterium *Nitrosomonas europaea*. *Archives of Biochemistry and Biophysics* 159 (1989): 640-643.
- Desbrow, C., Routledge, E. J., Brighty, G., Sumpter, J. P., and Waldock, M. Identification of estrogenic chemicals in STW effluent-I. Chemical fractionation and in vitro biological screening. *Environmental Science and Technology* 32 (1998): 1549-1558.
- Gaulke S. Linda., Strand E. Stuart., Kalthorn F. Thomas., and Stensel H. David., 17 $\alpha$ -ethynylestradiol transformation via abiotic nitration in the presence of ammonia oxidizing bacteria. (DOI: 10.1021/es801503u)
- Hanselman, T. A., Graetz, D. A., and Wilkie, A. C. Review of Manure-Borne Estrogens as Potential Environmental Contaminants. *Soil and Water Science Department* 33 (2003): 5471-5478.
- Institute of Population Health. Endocrine disruption[online]. University of Ottawa, R. Samuel McLaughlin Centre for Population Health Risk Assessment. 2007. Available from: <http://www.emcom.ca/EM/index.shtml> [2007, January 9]
- Irvin, R. S., Ann S., Jean, M. N., Daniel, G. C., and James, J. N. Short-Term exposure to 17 $\alpha$ -Ethinylestradiol decreases the fertility of sexually maturing male rainbow trout. *Setac Journal* DOI: 10.1897/1551-5028(2003)022<1272:STETED>2.0.CO;2
- Jobling, S., Sheaham, D. A., Osborne, J. A., Matthiessen, P., and Sumpter, J. P. Widespread sexual disruption in wild fish. *Environmental Science and Technology* 32 (1998): 2498-2506.
- Keener, K. William., and Arp, J. Daniel. Kinetic studies of ammonia monooxygenase inhibition in *Nitrosomonas europaea* by hydrocarbons and halogenated hydrocarbons in an optimized whole-cell assay. *Applied and Environment Microbiology* 59 (1993): 501-510.
- Koops, H. P., Purkhold, U., Pommeren, R. A., Timmermann, G., and Wagner, M. The Lithoautotrophic Ammonia-Oxidizing Bacteria. In M. Dworkin et al (eds.), *The Prokaryotes: An Evolving Electronic Resource For the Microbiological Community*, pp.1-22. New York, 2003.
- Limpiyakorn, T., Futoshi, K., Yoriko, S., and Osami, Y. Effects of ammonia and nitrite on communities and populations of ammonia-oxidizing bacteria in laboratory-scale continuous-flow reactors. *FEMS Microbiology Ecology* (DOI: 10.1111/j.1574-6941.2007.00307.x)
- Nitrogen cycle. The Michigan Water Research Center (MWRC) [online]. 2008. Available from : <http://mwrc.bio.cmich.edu/nitrogen.htm#The%20Nitrogen%20Cycle> [2008, February 15]
- Purdom, C. E., Hardiman, P. A., Bye, V. J., Eno, N. C., Tyler, C. R., and Sumpter, J. P. Estrogenic affects of effluents from sewage treatment works. *Journal Of Chemical Ecology* 8 (1994): 275-285.

- Sermwaraphan P. Degradation of 17 $\alpha$ -ethynylestradiol (EE2) by nitrifying activated sludge containing different ammonia oxidizing bacterial communities. Master's Thesis, Science Program in Environmental Management, Graduate School, Chulalongkorn University, 2006.
- Sharpe, R. M., and Skakkebaek, N. E. Are estrogens involved in falling sperm counts and disorders of the male reproductive tract? *Lancet* 341 (1993): 1392-1395.
- Shi, J., Fujisawa, S., Nakai, S., and Hosomi, M. Biodegradation of natural and synthetic estrogens by nitrifying activated sludge and ammonia-oxidizing bacterium *Nitrosomonas europaea*. *Water Research* 38 (2004): 2323-2330.
- Shore, L. S., Correll, D. L., and Chakraborty, P. K. Relationship of fertilization with chick manure and concentrations of estrogens in small streams. In Steele, K (ed.), *Animal waste and the land -water interface*, pp.155-162. Florida: CRC Press, 1995a.
- Sonthipan, P. Communities of ammonia oxidizing bacteria and archaea in full-scale WWTPs in Thailand. Master's Thesis, Science Program in Environmental Management, Graduate School, Chulalongkorn University, 2008.
- Strickland, J. D., and Parson, T. R. *A practical handbook of seawater analysis*. Fishery research board of Canada. Ottawa (1972), pp 310.
- Treusch, A. H., Leininger, S., Kletzin, A., Schuster, S.C., Klenk, H.P., and Schleper, C. Nitrification [online]. 2005. Available from: <http://en.wikipedia.org/wiki/Nitrification>
- Vader, J. S., Ginkel, C., Stokman, F. M., Sperling, G. M., Jong, J., Boer, W., Graaf, J., Most, M., and Stokman, P. Degradation of ethinyl estradiol by nitrifying activated sludge. *Chemosphere* 41 (2000): 1239-1243.
- Weber, S., Leuschner, P., Peter, K., Wolfgang, D., and Juliane, H. Degradation of Estradiol and Ethinyl estradiol by activated sludge and by a defined mixed culture. *Applied Microbiology and Biotechnology* 67 (2005): 106-112.



## **APPENDICES**

## **APPENDIX A**

**Table A-1** Degradation of EE2 by enriched nitrifying activated sludge from 2mM reactor with initial ammonium concentrations of 2mM

t (hr)	Ammonia concentrations (mg-N/L)			Nitrite concentrations (mg-N/L)			Nitrate concentrations (mg-N/L)			Estrogen concentrations (mg/L)		
	Degradation	Inhibition	Control	Degradation	Inhibition	Control	Degradation	Inhibition	Control	Degradation	Inhibition	Control
0	19.45	21.16	23.37	0.11	0.00	-0.01	0.75	2.74	-0.05	11.17	10.95	10.95
24	11.87			4.19			10.48			10.49		
48	0.75			3.13			15.45			10.05		
72	0.03			0.04			24.99			9.58		
96	0.01	21.78		0.02	0.00		23.56	1.98		8.63	10.21	
144	-0.02			0.00			19.55			8.54		
192	-0.02	20.92	21.34	0.00	0.00	0.02	23.08	3.77	0.46	8.42	10.41	11.24

**Table A-2** Degradation of EE2 by enriched nitrifying activated sludge from 2mM reactor with initial ammonium concentrations of 10mM

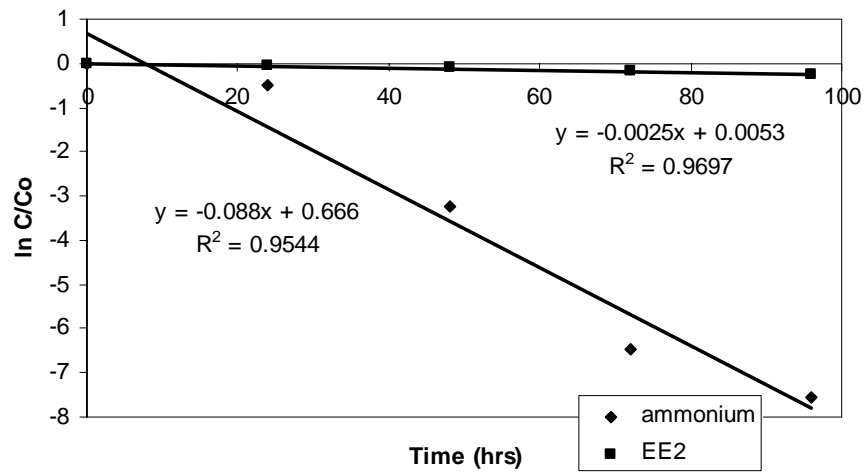
t (hr)	Ammonia concentrations (mg-N/L)			Nitrite concentrations (mg-N/L)			Nitrate concentrations (mg-N/L)			Estrogen concentrations (mg/L)		
	Degradation	Inhibition	Control	Degradation	Inhibition	Control	Degradation	Inhibition	Control	Degradation	Inhibition	Control
0	133.00	143.90	127.50	0.09	0.00	-0.01	0.89	3.44	-0.01	11.26	11.19	10.95
24	115.30			1.68			18.08			11.06		
48	107.30			2.28			27.52			10.34		
72	94.02			2.32			41.56			10.05		
120	79.36			9.05			61.32			9.84		
192	41.59	133.80		26.20	0.00		82.38	5.03		9.34	10.72	
264	0.99			14.40			139.30			7.93		
336	0.01			0.31			134.20			7.25		
408	0.02	117.90	118.70	0.00	-0.01	0.01	145.80	6.28	0.73	7.31	9.72	11.70

**Table A-3** Degradation of EE2 by enriched nitrifying activated sludge from 30mM reactor with initial ammonium concentrations of 2mM

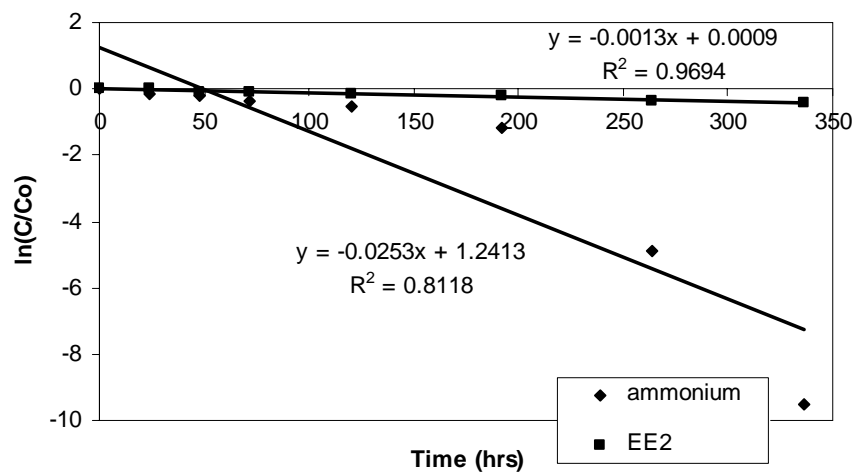
t (hr)	Ammonia concentrations (mg-N/L)			Nitrite concentrations (mg-N/L)			Nitrate concentrations (mg-N/L)			Estrogen concentrations (mg/L)		
	Degradation	Inhibition	Control	Degradation	Inhibition	Control	Degradation	Inhibition	Control	Degradation	Inhibition	Control
0	21.66	21.89	28.61	0.08	0.00	0.00	0.75	0.75	0.00	8.90	9.13	9.24
24	2.29			3.94			22.31			8.50		
48	0.06			0.00			26.54			8.27		
72	0.04			0.00			26.85			8.03		
96	0.03	21.48		0.00	0.01		25.60	1.31		7.96	9.06	
144	-0.01			0.00			28.90			7.90		
192	-0.02	20.72	27.34	0.00	-0.01	0.00	31.57	2.38	0.45	7.93	8.61	9.38

**Table A-4** Degradation of EE2 by enriched nitrifying activated sludge from 30mM reactor with initial ammonium concentrations of 10mM

t (hr)	Ammonia concentrations (mg-N/L)			Nitrite concentrations (mg-N/L)			Nitrate concentrations (mg-N/L)			Estrogen concentrations (mg/L)		
	Degradation	Inhibition	Control	Degradation	Inhibition	Control	Degradation	Inhibition	Control	Degradation	Inhibition	Control
0	140.70	120.70	130.1	0.08	0.01	0.00	0.58	0.84	-0.06	9.02	9.16	9.14
24	115.70			6.48			16.39			8.65		
48	81.28			15.10			33.44			8.28		
96	30.14			39.30			56.54			8.06		
144	20.88			43.60			71.05			7.91		
168		112.20			0.00			1.86			8.52	
192	0.08			14.10			117.70			7.92		
240	0.05			0.00			125.80			7.93		
288	-0.04	124.8	131.30	0.00	0.00	0.00	129.00	2.37	0.40	7.92	8.69	9.24

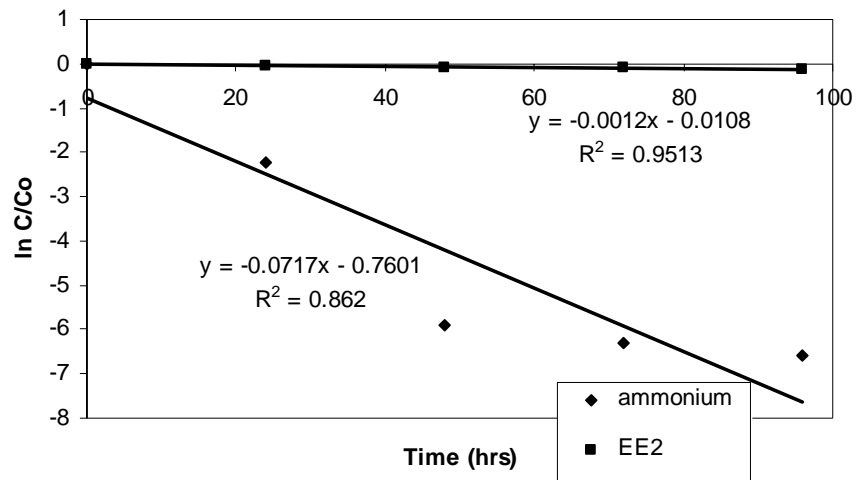


(a)

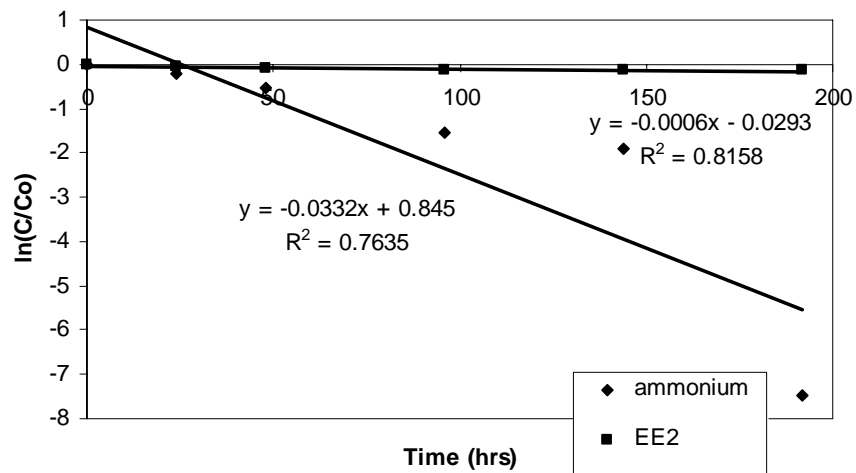


(b)

**Figure A-1** First-order reaction kinetic of ammonium and estrogens during degradation of EE2 by enriched nitrifying activated sludge from 2 mM reactor with initial ammonium concentrations of 2 mM (a) and 10 mM (b)



(a)



(b)

**Figure A-2** First-order reaction kinetic of ammonium and estrogens during degradation of EE2 by enriched nitrifying activated sludge from 30 mM reactor with initial ammonium concentrations of 2 mM (a) and 10 mM (b)



## **APPENDIX B**

**Table B-1** Degradation of EE2 by sludge from MWWTP-A with initial ammonium concentrations of 2mM

t (hr)	Ammonia concentrations (mg-N/L)			Nitrite concentrations (mg-N/L)			Nitrate concentrations (mg-N/L)			Estrogen concentrations (mg/L)		
	Degradation	Inhibition	Control	Degradation	Inhibition	Control	Degradation	Inhibition	Control	Degradation	Inhibition	Control
0	24.10	17.77	23.37	0.01	0.00	-0.01	-0.38	2.28	-0.05	10.90	10.85	10.95
24	22.31			0.02			10.22			10.76		
48	16.09			0.01			12.2			10.51		
96	6.79	18.42		0.03	-0.01		26.14	2.68		10.06	10.95	
144	0.96			0.05			22.99			9.73		
192	-0.05	19.07	21.34	0.00	-0.01	0.02	32.75	3.40	0.46	9.20	10.18	11.24

**Table B-2** Degradation of EE2 by sludge from MWWTP-A with initial ammonium concentrations of 10mM

t (hr)	Ammonia concentrations (mg-N/L)			Nitrite concentrations (mg-N/L)			Nitrate concentrations (mg-N/L)			Estrogen concentrations (mg/L)		
	Degradation	Inhibition	Control	Degradation	Inhibition	Control	Degradation	Inhibition	Control	Degradation	Inhibition	Control
0	102.20	110.50	127.50	0.00	0.00	-0.01	0.32	3.07	-0.01	10.97	10.95	10.95
24	106.40			0.01			15.47			10.97		
48	124.20			0.02			13.05			10.95		
96	119.40			0.07			17.48			10.60		
144	129.90			2.45			31.32			10.23		
216	60.51			20.10			88.43			7.97		
264	-0.01			47.40			121.50			7.69		
360	-0.04			16.60			143.20			6.47		
408	-0.03	114.90	118.70	-0.09	-0.01	0.01	160.7	4.51	0.73	6.95	9.78	11.70

**Table B-3** Degradation of EE2 by sludge from MWWTP-B with initial ammonium concentrations of 2mM

t (hr)	Ammonia concentrations (mg-N/L)			Nitrite concentrations (mg-N/L)			Nitrate concentrations (mg-N/L)			Estrogen concentrations (mg/L)		
	Degradation	Inhibition	Control	Degradation	Inhibition	Control	Degradation	Inhibition	Control	Degradation	Inhibition	Control
0	24.05	22.19	28.61	0.01	0.00	0.00	0.34	0.40	0.00	8.99	8.97	9.24
24	17.36			0.14			7.90			8.60		
48	10.51			1.54			16.24			8.51		
72	8.50			1.20			17.83			8.27		
96	-0.01	19.10		1.65	-0.01		29.79	0.57		8.12	8.79	
144	-0.03			0.29			28.19			8.06		
192	-0.03	21.16	27.34	0.00	-0.01	0.00	31.62	0.81	0.45	8.06	8.69	9.38

**Table B-4** Degradation of EE2 by sludge from MWWTP-B with initial ammonium concentrations of 10mM

t (hr)	Ammonia concentrations (mg-N/L)			Nitrite concentrations (mg-N/L)			Nitrate concentrations (mg-N/L)			Estrogen concentrations (mg/L)		
	Degradation	Inhibition	Control	Degradation	Inhibition	Control	Degradation	Inhibition	Control	Degradation	Inhibition	Control
0	123.30	110.00	130.10	0.02	0.00	0.00	0.47	0.84	-0.06	8.96	9.04	9.14
24	126.80			0.23			6.05			8.87		
48	114.40			1.10			14.61			8.67		
96	101.60			3.46			20.75			8.38		
144	75.85			8.82			48.08			8.06		
168		98.92			0.00			1.06			8.85	
192	74.99			9.90			54.48			8.02		
288	60.79			9.74			69.04			7.98		
336	5.00			19.40			111.40			7.72		
384	-0.02	101.80	128.20	0.62	0.01	0.01	140.30	1.41	0.40	7.66	8.68	9.12

**Table B-5** Degradation of EE2 by sludge from IWWTP-A with initial ammonium concentrations of 2mM

t (hr)	Ammonia concentrations (mg-N/L)			Nitrite concentrations (mg-N/L)			Nitrate concentrations (mg-N/L)			Estrogen concentrations (mg/L)		
	Degradation	Inhibition	Control	Degradation	Inhibition	Control	Degradation	Inhibition	Control	Degradation	Inhibition	Control
0	22.43	19.45	23.37	0.02	0.00	-0.01	-0.54	2.34	-0.05	11.23	11.02	10.95
24	18.38			0.13			15.40			10.90		
48	13.51			0.15			17.83			11.07		
72	0.08			0.02			32.72			10.56		
96	0.94	21.87		0.12	0.00		27.14	2.59		10.59	10.66	
120	0.02			0.01			25.56			10.54		
144	0.01			0.02			31.29			10.39		
192	-0.02	21.10	21.34	-0.01	-0.01	0.02	32.12	2.77	0.46	9.46	9.63	11.24

**Table B-6** Degradation of EE2 by sludge from IWWTP-A with initial ammonium concentrations of 10mM

t (hr)	Ammonia concentrations (mg-N/L)			Nitrite concentrations (mg-N/L)			Nitrate concentrations (mg-N/L)			Estrogen concentrations (mg/L)		
	Degradation	Inhibition	Control	Degradation	Inhibition	Control	Degradation	Inhibition	Control	Degradation	Inhibition	Control
0	122.02	124.07	127.50	0.02	0.00	-0.01	0.87	3.72	-0.01	10.97	11.20	10.95
24	124.24			0.10			13.91			11.05		
48	108.48			0.63			33.20			10.73		
96	96.95			1.47			44.77			10.72		
120	66.31	131.72		6.62	-0.01		66.94	3.73		9.89	10.25	
192	52.30			8.18			64.25			9.74		
264	17.29			0.34			108.80			7.71		
336	-0.02			-0.01			135.00			7.35		
408	0.03	129.40	118.70	0.00	-0.01	0.01	127.20	4.10	0.73	7.29	10.06	11.70

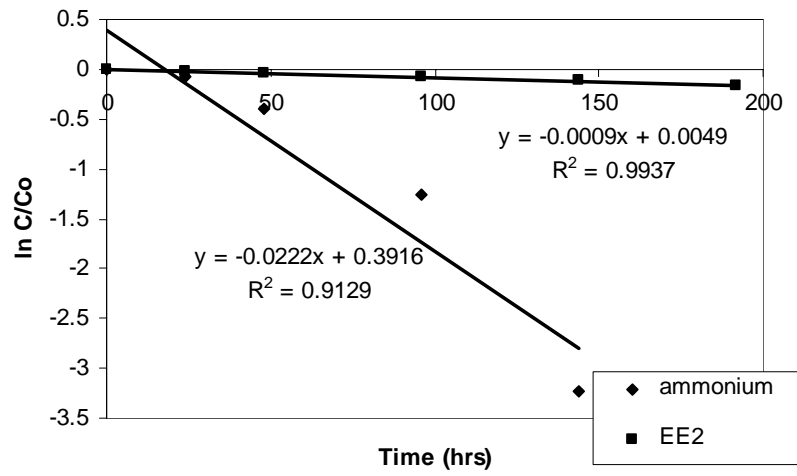
**Table B-7** Degradation of EE2 by sludge from IWWTP-B with initial ammonium concentrations of 2mM

t (hr)	Ammonia concentrations (mg-N/L)			Nitrite concentrations (mg-N/L)			Nitrate concentrations (mg-N/L)			Estrogen concentrations (mg/L)		
	Degradation	Inhibition	Control	Degradation	Inhibition	Control	Degradation	Inhibition	Control	Degradation	Inhibition	Control
0	23.57	22.87	28.61	0.02	0.03	0.00	0.52	1.00	0.00	9.10	9.12	9.24
24	17.78			0.19			7.96			8.69		
48	10.39			0.80			12.29			8.33		
72	0.64			1.19			28.19			8.21		
96	-0.03	20.19		0.02	-0.01		27.47	0.47		8.22	8.83	
144	-0.01			0.00			29.44			8.09		
192	-0.52	22.60	27.34	-0.01	0.00	0.00	30.68	0.93	0.45	8.07	8.34	9.38

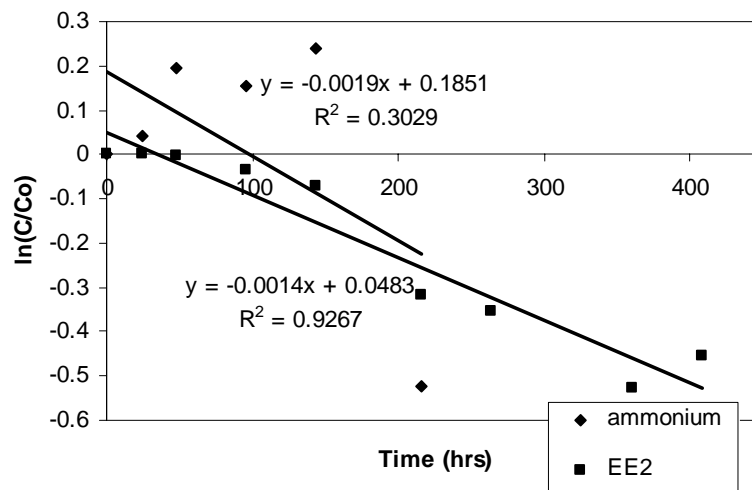


**Table B-8** Degradation of EE2 by sludge from IWWTP-B with initial ammonium concentrations of 10mM

t (hr)	Ammonia concentrations (mg-N/L)			Nitrite concentrations (mg-N/L)			Nitrate concentrations (mg-N/L)			Estrogen concentrations (mg/L)		
	Degradation	Inhibition	Control	Degradation	Inhibition	Control	Degradation	Inhibition	Control	Degradation	Inhibition	Control
0	131.3	119.40	130.10	0.01	0.00	0.00	0.57	0.84	-0.06	9.02	9.07	9.14
24	114.90			5.19			4.68			8.80		
48	113.80			7.61			8.05			8.68		
96	93.44			9.12			26.28			8.61		
144	52.46			19.40			71.24			8.30		
168		120.20			0.00			1.41			8.81	
192	21.72			39.10			75.90			8.18		
240	4.39			39.80			98.63			8.27		
288	1.89			44.00			91.48			8.29		
336	0.09			3.82			140.60			8.31		
384	-0.03	116.70	128.20	0.96	0.00	0.01	132.60	1.53	0.40	8.31	8.65	9.12

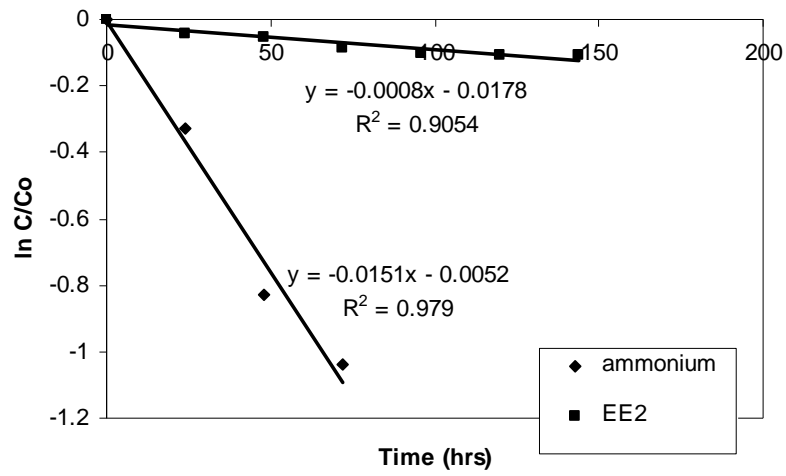


(a)

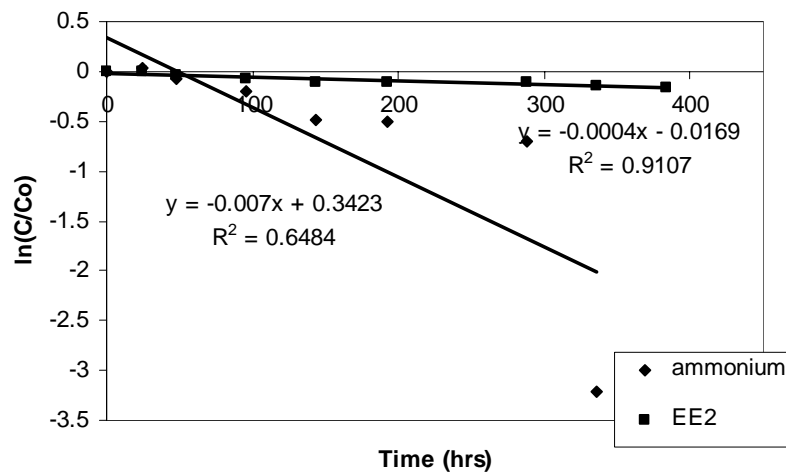


(b)

**Figure B-1** First-order reaction kinetic of ammonium and estrogens during degradation of EE2 by nitrifying activated sludge from MWWTP-A with initial ammonium concentrations of 2 mM (a) and 10 mM (b)

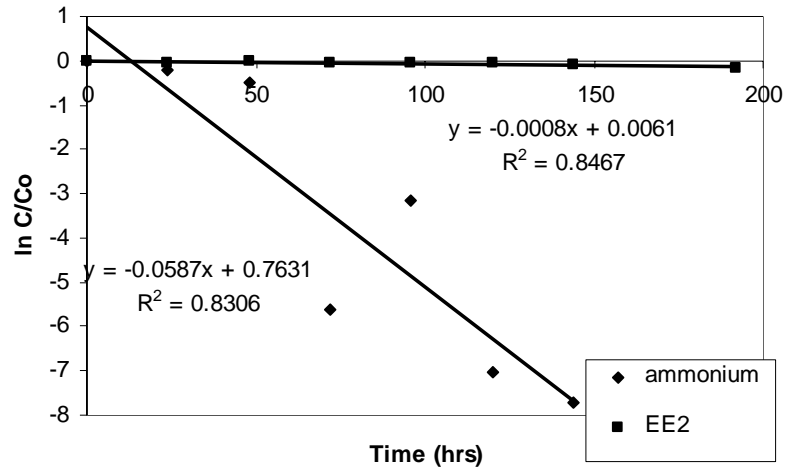


(a)

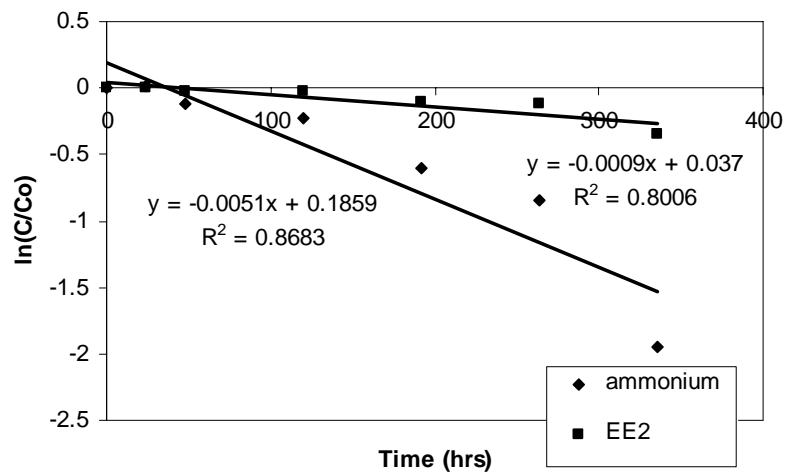


(b)

**Figure B-2** First-order reaction kinetic of ammonium and estrogens during degradation of EE2 by nitrifying activated sludge from MWWTP-B with initial ammonium concentrations of 2 mM (a) and 10 mM (b)

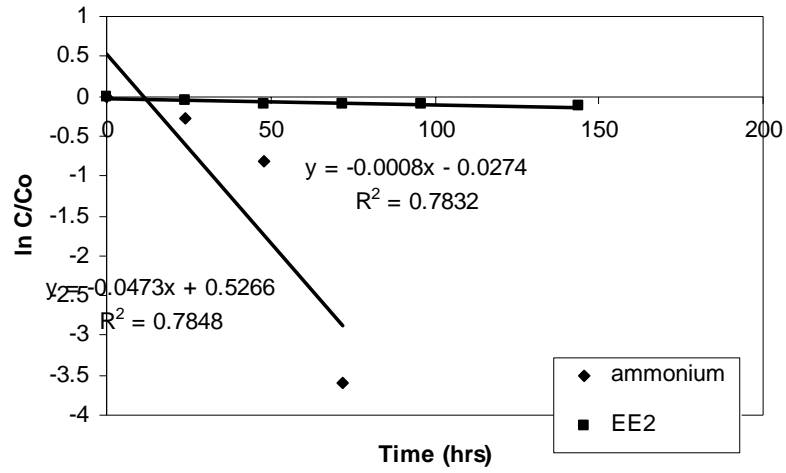


(a)

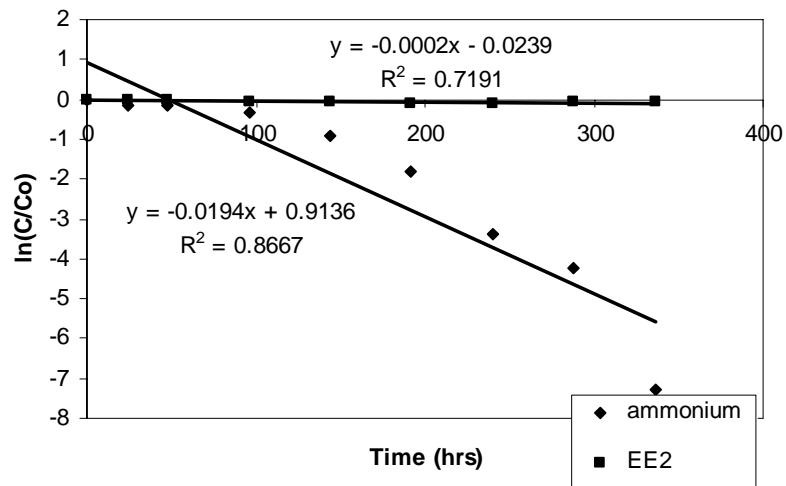


(b)

**Figure B-3** First-order reaction kinetic of ammonium and estrogens during degradation of EE2 by nitrifying activated sludge from IWWTP-A with initial ammonium concentrations of 2 mM (a) and 10 mM (b)



(a)



(b)

**Figure B-4** First-order reaction kinetic of ammonium and estrogens during degradation of EE2 by nitrifying activated sludge from IWWTP-B with initial ammonium concentrations of 2 mM (a) and 10 mM (b)

## **BIOGRAPHY**

Miss Napasawan Khongkham was born on July 9, 1984 in Angthong province, Thailand. She graduated her B.Sc. Degree in Environmental Science from the Faculty of Science of Silpakorn University in 2006. She was educated her Master Degree at The International Postgraduate Programs in Environmental Management, Inter-Department of Environment Management, Chulalongkorn University, Bangkok, Thailand since May 2006. She finished her Master of Science Degree in Environmental Management in May 2008.