

THE EFFECT OF A TREHALASE INHIBITOR, VALIDAMYCIN A, ON THE GROWTH OF
ASPERGILLUS FLAVUS

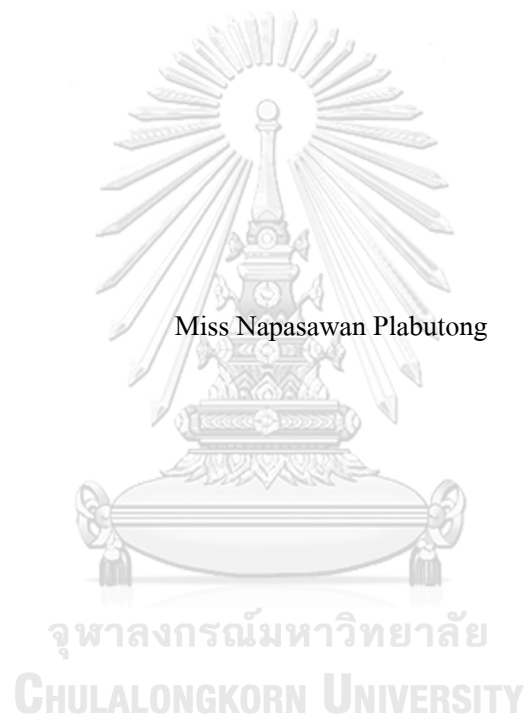

A Thesis Submitted in Partial Fulfillment of the Requirements
for the Degree of Master of Science in Medical Microbiology

Medical Microbiology, Interdisciplinary Program

GRADUATE SCHOOL

Chulalongkorn University

Academic Year 2019

Copyright of Chulalongkorn University

การศึกษาผลของสารต้านการทำงานของเอนไซม์ trehalase , validamycin A , ต่อการเจริญของเชื้อ
Aspergillus flavus



วิทยานิพนธ์นี้เป็นส่วนหนึ่งของการศึกษาตามหลักสูตรปริญญาวิทยาศาสตรมหาบัณฑิต
สาขาวิชาจุลชีววิทยาทางการแพทย์ สหสาขาวิชาจุลชีววิทยาทางการแพทย์
บัณฑิตวิทยาลัย จุฬาลงกรณ์มหาวิทยาลัย
ปีการศึกษา 2562
ลิขสิทธิ์ของจุฬาลงกรณ์มหาวิทยาลัย

นักสวรรณ ปลายู่ทอง : การศึกษาผลของสารต้านการทำงานของเอนไซม์ trehalase , validamycin A , ต่อการเจริญของเชื้อ *Aspergillus flavus*. (THE EFFECT OF A TREHALASE INHIBITOR, VALIDAMYCIN A, ON THE GROWTH OF *ASPERGILLUS FLAVUS*) อ.ที่ปรึกษาหลัก : ดร. นพ.อาสา ชรรณหงส์, อ.ที่ปรึกษาร่วม : ดร. นพ.ดิเรกฤทธิ์ เชี่ยวเชิงชล

Aspergillus flavus เป็นเชื้อที่สามารถพบได้ในสิ่งแวดล้อม สามารถก่อโรคติดเชื้อทางตา ทางผิวหนัง ทางโพรงจมูก และโรคติดเชื้อที่ปอดแบบลุกลามในมนุษย์ได้ สำหรับการรักษาในปัจจุบัน มีการใช้ต้านเชื้อราในการยับยั้งการเจริญเติบโตของเชื้อ แต่อย่างไรก็ตามยาต้านเชื้อรา สำหรับเชื้อ *A. flavus* ล้วนมีผลข้างเคียงต่อมนุษย์ ขณะเดียวกันในเชื้อราส่วนใหญ่ พบว่ามี trehalase ซึ่งเป็นเอนไซม์ที่ทำหน้าที่ในการย่อย trehalose เป็นกลูโคสสองโมเลกุลและ trehalose มีความสำคัญในการก่อให้เกิดโรคของเชื้อราหลายชนิด ในการศึกษาครั้งนี้จึงได้นำ validamycin A ซึ่งเป็น trehalase inhibitor และมีฤทธิ์ยับยั้งการเจริญของเชื้อราที่ก่อโรคในต้นข้าว คือ *Rhizoctonia solani* มาศึกษาผลการยับยั้งการเจริญเติบโตของเชื้อ *A. flavus* โดยพบว่า validamycin A เพิ่มระดับของ trehalose ในสปอร์อย่างมีนัยสำคัญ และสามารถลดการเจริญของสปอร์ (germination) ของเชื้อ *A. flavus* ได้ นอกจากนี้ยังได้ตรวจสอบผลการทำงานร่วมกันของ validamycin A กับยาต้านเชื้อรา amphotericin B โดยใช้วิธี checkerboard assay ทดสอบกับเชื้อ *A. flavus* ATCC 204304 และเชื้อ *A. flavus* ที่ได้มาจากตัวอย่างผู้ป่วยที่มีค่า minimum inhibitory concentrations (MICs) ของ amphotericin B ที่สูงกว่ามาตรฐาน และพบว่า ในการยับยั้งการเจริญของเชื้อ *A. flavus* ที่ได้มาจากตัวอย่างคนไข้ นั้น validamycin A และ amphotericin B นั้นมีผลเสริมฤทธิ์ซึ่งกันและกัน (Synergistic effect) อีกทั้งยังพบว่า validamycin A นั้นไม่มีความเป็นพิษต่อ human bronchial epithelial cells จากผลการศึกษาดังกล่าว สามารถสรุปได้ว่า validamycin A สามารถยับยั้งการเจริญเติบโตของเชื้อ *A. flavus* ได้ โดยหนึ่งกลไกเบื้องหลังในการทำงานของ validamycin A คือการลดการเจริญของสปอร์ (Delayed germination) ของเชื้อ *A. flavus* นอกจากนี้ validamycin A ยังมีฤทธิ์เสริมกันกับยาต้านเชื้อรา amphotericin B โดยไม่มีผลกระทบต่อ human bronchial epithelial cells อย่างมีนัยสำคัญ

สาขาวิชา จุลชีววิทยาทางการแพทย์
ปีการศึกษา 2562

ลายมือชื่อนิสิต
ลายมือชื่อ อ.ที่ปรึกษาหลัก
ลายมือชื่อ อ.ที่ปรึกษาร่วม

6087288520 : MAJOR MEDICAL MICROBIOLOGY

KEYWORD: Trehalase enzyme *Aspergillus flavus* validamycin A

Napasawan Plabutong : THE EFFECT OF A TREHALASE INHIBITOR, VALIDAMYCIN A, ON THE GROWTH OF *ASPERGILLUS FLAVUS*. Advisor: ARSA THAMMAHONG, M.D., PhD Co-advisor: DIREKRIT CHIEWCHENGCHOL, M.D., Ph.D.

Aspergillus flavus is a fungus found in the environment causing keratitis, cutaneous infections, sinusitis, invasive pulmonary aspergillosis in humans. Although this fungus can be treated with antifungal agents, these main antifungal agents have many side effects. Trehalase is an enzyme for digesting trehalose into two glucose subunits and is essential for virulence in many fungi. A trehalase inhibitor, called validamycin A, has been used effectively against a rice fungal pathogen, *Rhizoctonia solani*. In this study, we observed that validamycin A increased trehalose levels significantly in *A. flavus* spores and delayed the germination of those spores. In addition, to further investigate the combinative effect of validamycin A with an antifungal agent, amphotericin B, the checkerboard assay was performed with *A. flavus* ATCC204304 and *A. flavus* clinical isolates with high minimum inhibitory concentrations (MICs) of amphotericin B. We observed that validamycin A and amphotericin B had a synergistic effect with these *A. flavus* clinical isolates. The cytotoxicity of validamycin A to human bronchial epithelial cells was not observed in this study. In conclusion, this study showed that validamycin A was able to inhibit the growth of *A. flavus*. One of the mechanisms behind the effect of validamycin A was to delay the germination of *A. flavus* spores. Furthermore, validamycin A also possessed a combinative effect with amphotericin B without significant cytotoxic effect on human bronchial epithelial cells.

Field of Study: Medical Microbiology

Student's Signature

Academic Year: 2019

Advisor's Signature

Co-advisor's Signature

ACKNOWLEDGEMENTS

I have been accompanied and supported by many people. Without their passionate participation and help, this research project could not have been successfully completed. First of all, I would like to express my sincere gratitude to my advisor, Arsa Thammahong, M.D., Ph.D., and my thesis co-advisor, Direkrit Chewichengchol, M.D., Ph.D., at the Department of Microbiology, Faculty of Medicine, Chulalongkorn University, for their constant support throughout my master's degree. Thank you for their advice, attention and motivation throughout my research. Their advice helped me all the time in researching and writing for this thesis.

I would like to acknowledge Sita Virakul, Ph.D., and all members in Sita Virakul's Laboratory at the Department of Microbiology, Faculty of Science, Chulalongkorn University, for technical assistance on LDH cytotoxicity assay.

This research has received support from Ratchadapiseksompotch Fund, Faculty of Medicine, Chulalongkorn University, grant number RA61/045.

Thanks to all staffs of the Department of Microbiology, Faculty of Medicine, Chulalongkorn University, for their kindness and support.

Thanks to all members DC-AT Laboratory at the Department of Microbiology, Faculty of Medicine, Chulalongkorn University, for their support and encouragement.

Finally, I would like to express my gratitude to my family for their understanding, support and encouragement throughout my master's degree of study.

Napasawan Plabutong

TABLE OF CONTENTS

	Page
ABSTRACT (THAI).....	iii
ABSTRACT (ENGLISH).....	iv
ACKNOWLEDGEMENTS.....	v
TABLE OF CONTENTS.....	vi
LIST OF TABLES.....	ix
LIST OF FIGURES.....	x
LIST OF ABBREVIATIONS.....	1
CHAPTER I INTRODUCTION.....	3
Background information and rationale.....	3
Hypothesis.....	6
Objectives.....	6
CHAPTER II LITERATURE REVIEW.....	7
1. <i>Aspergillus flavus</i>	7
1.1 Epidemiology of <i>Aspergillus flavus</i>	8
1.2 Microbiology of <i>Aspergillus flavus</i>	8
1.3 Pathogenesis and virulence factors of <i>Aspergillus flavus</i>	9
1.4 Diseases.....	10
1.5 Diagnosis of invasive aspergillosis.....	11
1.6 Treatment of invasive aspergillosis.....	13
1.7 Antifungal resistance in <i>Aspergillus flavus</i>	15
2. Trehalose pathway and fungal pathogens.....	16

3. Trehalase enzymes	22
4. Validamycin A and fungal pathogens	23
CHAPTER III MATERIALS AND METHODS.....	26
1. Fungal strain, media, and conditions.....	26
2. Trehalose measurement.....	27
3. Germination assay	27
4. XTT assay	28
5. Broth microdilution assay and checkerboard assay	28
6. Time-kill kinetics assay.....	29
7. Cell lines and culture.....	29
8. Cytotoxicity assay	30
9. Statistical analysis	30
10. Ethics statement.....	31
CHAPTER IV RESULTS.....	32
1. Trehalase homologs exist in <i>Aspergillus flavus</i>	32
2. Validamycin A inhibits the growth of <i>Aspergillus flavus</i> and increases conidial trehalose levels with delayed conidial germination.....	36
3. Validamycin A has a synergistic effect with amphotericin B in <i>A. flavus</i> clinical isolates with high MICs of amphotericin B	42
4. Validamycin A has no cytotoxicity to human bronchial epithelial cells.....	46
CHAPTER V DISCUSSION AND CONCLUSION.....	48
REFERENCES	54
VITA	56
APPENDIX I.....	69

<i>Aspergillus flavus</i> and <i>Aspergillus fumigatus</i> are able to utilize trehalose as a sole carbon source.	69
APPENDIX II	71
Validamycin A inhibits the growth of <i>Aspergillus flavus</i>	71
APPENDIX III.....	73
1. Validamycin A has combinative effects against <i>Aspergillus flavus</i> ATCC204304 and <i>Aspergillus flavus</i> clinical isolates	73
2. Time-kill kinetics assay.....	78
APPENDIX IV.....	81
Validamycin A has no cytotoxicity to human bronchial epithelial cell lines.....	81

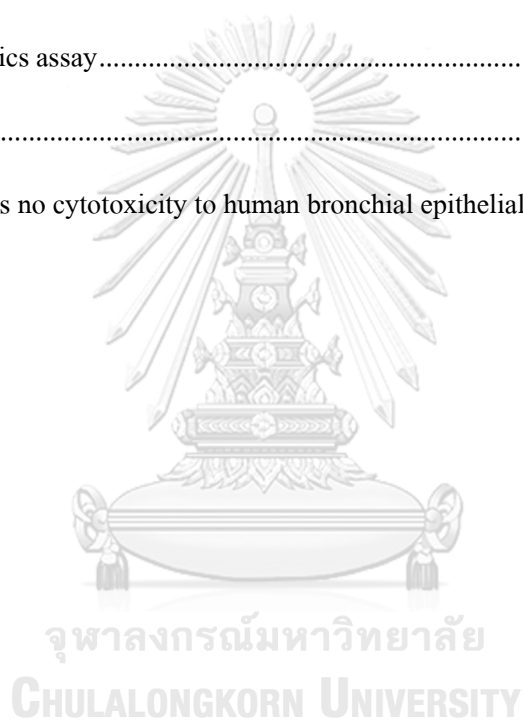

LIST OF TABLES

	Page
Table 1. The diagnosis of invasive aspergillosis using EORTC/MSG	11
Table 2. Patient characteristics and fractional inhibitory concentration index (FICI) of Aspergillus flavus clinical isolates with high amphotericin B minimum inhibitory concentrations (MICs) (Interpretation: A: additive; S: synergistic).....	44



LIST OF FIGURES

	Page
Figure 1. Trehalose metabolic pathway.	17
Figure 2. The trehalose biosynthetic pathways.....	19
Figure 3. Localization of trehalase enzymes.....	22
Figure 4. Structure of trehalose and validamycin A.	24
Figure 5. <i>Aspergillus flavus</i> possesses trehalase homologs.	33
Figure 6. <i>Aspergillus flavus</i> utilizes trehalose as a sole carbon source similar to glucose.....	36
Figure 7. The hypothesis of the mechanism of validamycin against acid trehalase and neutral trehalase.	38
Figure 8. Validamycin A inhibits the growth and increases trehalose level in <i>Aspergillus flavus</i> conidia with delayed conidial germination.	41
Figure 9. Validamycin A has a synergistic effect with amphotericin B against <i>A. flavus</i> clinical isolates.....	45
Figure 10. Validamycin A and the combination of validamycin A and amphotericin B have no cytotoxic effect on human bronchial epithelial cells.	46
Figure 11. Model of the effects of validamycin A on the growth of <i>Aspergillus flavus</i> and the combinative effects of validamycin A and amphotericin B.....	53

LIST OF ABBREVIATIONS

ATCC	American Type Culture Collection
ATP	Adenosine triphosphate
<i>Afu</i>	<i>Aspergillus fumigatus</i>
<i>Afla</i>	<i>Aspergillus flavus</i>
Ath1p	Acid trehalase
BEAS-2B	Human bronchial epithelial cell line
BSA	Bovine serum albumin
CFU	Colony-Forming Unit
°C	Degree Celsius
ECV	Epidemiological Cutoff Value
EORTC/MSG	European Organization for the Research and Treatment of Cancer/Mycoses Study Group
FICI	Fractional inhibitory concentration index
G6P	Glucose 6-phosphate
IA	Invasive aspergillosis
LD50	Lethal dose at 50 percentage
LDH	Lactate Dehydrogenase

mg	Milligram
MIC	Minimum inhibitory concentration
mL	Milliliter
NADH/NAD ⁺	Nicotinamide adenine dinucleotide (NAD) + hydrogen (H)
nm	nanometer
Nth1p	Neutral trehalase
OD	Optical density
<i>Sc</i>	<i>Saccharomyces cerevisiae</i>
SDA	Sabouraud Dextrose Agar
Tps1p	Trehalose-6-phosphate synthase
Tps2p	Trehalose-6-phosphate phosphatase
UDP-G	Uracil-diphosphate glucose, UDP-glucose
XTT	(sodium 2,3-bis (2-methoxy-4-intro-5-sulfo-phenyl)-5- [(phenylamino)-carbonyl]-2H-tetrazolium)
μg	Microgram
μl	Microliter
μM	Micromolar

CHAPTER I INTRODUCTION

Background information and rationale

Currently, patients with impaired immune status have increased in number every year, such as AIDS patients, patients with organ transplantation receiving immunosuppressive agents, cancer patients receiving chemotherapy or radiotherapy, and hematological cancer patients, including patients with abnormal immune status from complications or side effects from medications., e.g. diabetic patients, who cannot control their blood sugar levels and SLE (Systemic Lupus Erythematosus) patients, who take steroids (1). This increase would result in an increased incidence of opportunistic infections, including bacteria, e.g. *Mycobacterium avium* complex (MAC); viruses, e.g. Cytomegalovirus, Varicella Zoster Virus; fungi, e.g. *Aspergillus* spp., *Cryptococcus neoformans*, and parasites, e.g. *Toxoplasma gondii* (1). These infections are generally non-pathogenic in immunocompetent hosts.

Furthermore, these opportunistic infections are clearly increasing in many countries, including in Japan (2), India (3), Australia (4), and Thailand (5-8). *Candida* species are the most common cause of the opportunistic yeast infections, while *Aspergillus* species are the most common cause of mold infections. At King Chulalongkorn Memorial Hospital, from 2006 to 2011, *Aspergillus* infections had an

increased rate of infections every year. For invasive mold infections, *A. fumigatus* was the main causative agent, followed by *A. flavus* (9-11). Nevertheless, in non-HIV and non-burn patients, *Aspergillus flavus* caused infections more than other *Aspergillus* species (10).

Aspergillus flavus is a fungus that can be found in the environment. This fungus can also produce aflatoxins, which are toxins contaminated in many agricultural crops may lead to a liver cancer in humans (12). Furthermore, *A. flavus* is able to grow at high temperatures and can cause a wide variety of disease spectra in humans, i.e., keratitis, cutaneous infections, sinusitis, and invasive infections (10, 13, 14). Although *A. fumigatus* is the most common cause of invasive aspergillosis in the United States, *A. flavus* is a more common cause of cutaneous infections and invasive sinusitis infections in India (13, 14). However, the study of epidemiology and pathogenesis of *A. flavus* infections in humans is still limited in comparison to other *Aspergillus* species (3).

For the treatment of invasive aspergillosis from *Aspergillus flavus*, voriconazole is the drug of choice together with surgery (15). Voriconazole, however, has many adverse reactions, e.g. the transient visual disturbances, hepatotoxicity, tachyarrhythmias and QT interval prolongations (16). For superficial skin infections

from *A. flavus*, topical ketoconazole is not active, and the recurrent infections are common (10). Nonetheless, itraconazole also has many drug-drug interactions, e.g. with some chemotherapeutic agents (cyclophosphamide and vincristine) and causes hepatotoxicity and prolonged QTc interval (16). Amphotericin B is an antifungal drug which is used to treat severe fungal infections. However, amphotericin B has serious side effects on nephrotoxicity (17).

In addition, even if the patient is receiving antifungal drugs as standard, patients with invasive aspergillosis had a high mortality rate in the range of 45-80% (18). Thus, the discovery of novel antifungal agents and fewer side effects to the patients are the most important for the treatment of *Aspergillus* fungal infections. As mentioned above, many main antifungal agents have a lot of side effects. Therefore, the disruption of virulence factor or metabolic pathway specific to the fungus, not in humans, maybe an alternative way to develop new antifungal agents that are specific to the fungus and reduce unwanted side effects in humans (19, 20). Thus, this study has the ultimate goal to develop a novel but a less toxic antifungal agent that will be specific to only fungi.

Hypothesis

Validamycin A inhibits trehalase enzyme affecting the growth of *Aspergillus flavus*.

Objectives

1. To study the effect of validamycin A (a trehalase inhibitor) on the growth of *Aspergillus flavus*.
2. To study the additive/synergistic effect of validamycin A and amphotericin B, a fungicidal antifungal agent.
3. To study the toxicity of validamycin A to human cell lines.

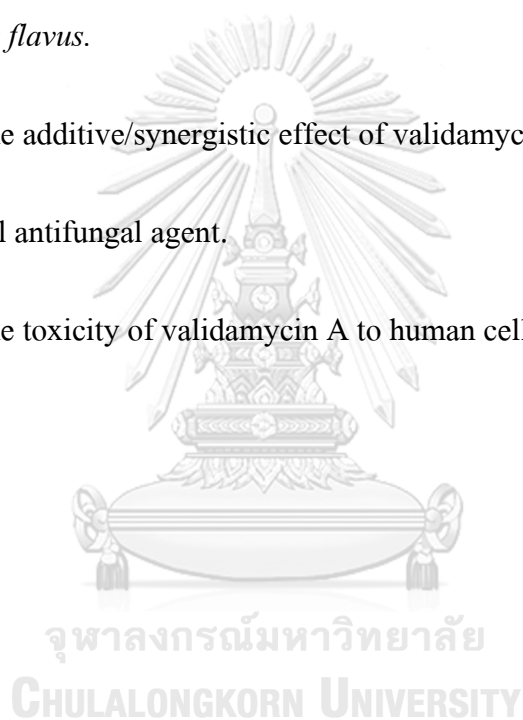

CHAPTER II LITERATURE REVIEW

1. *Aspergillus flavus*

Aspergillus flavus is in the family Trichocomaceae of the order Eurotiales of Ascomycetes (13). *A. flavus* is a saprophytic fungus found in the environment. It is in *A. flavus* complex mainly consisting of *A. flavus*, *A. oryzae*, *A. avenaceus*, *A. tamari*, *A. alliaceus*, and *A. nomius* (13). Many species in this complex, including *A. flavus*, can produce aflatoxins, e.g. aflatoxin B₁, which is the most toxic and causes a liver cancer in humans (12, 13, 21). However, in this complex, only *A. flavus* is the main fungus causing diseases in both humans, animals, and plants (13, 22).

A. flavus is able to grow at high temperatures and causes many infection forms in humans, i.e. keratitis, cutaneous infections, sinusitis, and invasive aspergillosis (10, 13, 14). Although *Aspergillus fumigatus* is the most common cause of invasive aspergillosis in the United States, *A. flavus* is a common cause of cutaneous infections and sinusitis in South Asia, e.g. India, Sri Lanka (13, 14). However, epidemiological and pathogenesis studies of *A. flavus* infections in humans is still limited in comparison to other *Aspergillus* species (3).

1.1 Epidemiology of *Aspergillus flavus*

A. flavus is a ubiquitous fungus found in air, soil, dust, and environment (13, 22). It is also found in contaminated crops, e.g. peanuts, grains, and corn (23). In some developing countries, e.g. India, Sri Lanka, *A. flavus* was isolated at higher frequency from invasive sino-orbital aspergillosis or *Aspergillus* eye infections/skin infections. In India, many studies reported that *A. flavus* is the most common mold infections in fungal rhinosinusitis and fungal keratitis (24-28). In Taiwan, *A. flavus* was the most common mold isolated from invasive sinusitis in patients with hematological malignancy. *A. flavus* is also common invasive mold infections in the Middle East and Africa (15, 29). In Thailand, for invasive aspergillosis, *A. fumigatus* is the most common followed by *A. flavus* (30). Nonetheless, the epidemiological study of *A. flavus* in Thailand is still limited. Therefore, further epidemiological studies of a wide variety of *A. flavus* infections in humans are still necessary.

1.2 Microbiology of *Aspergillus flavus*

Macroscopic colonies of *A. flavus* are granular to powdery in texture with radial grooves. Colony surface color is yellow to yellowish green depending on age of *A. flavus*. *A. flavus* has a hyaline septate hyphae with rough conidiophore (up to 800 μm long and 15-20 μm wide) and globose vesicle (20-45 μm) with radiations (15). It

can be uniseriate attaching to vesicle directly or biseriate attaching to metulae (supporting cells) (15). The *A. flavus* conidia are about 2-5 μm in diameter (15). Sclerotia may be observed and can be used to identify *A. flavus* in some special media, e.g. Czapek Dox media (15). It can grow on Sabouraud dextrose agar, Czapek Dox, and malt extract agar at 37°C (15).

1.3 Pathogenesis and virulence factors of *Aspergillus flavus*

For the pathogenesis of *A. flavus* in human infections, it is believed to be similar to *A. fumigatus* because of the lack of solid evidence in *A. flavus* (13, 15). In *A. fumigatus*, conidia are inhaled into alveoli of immunocompromised patients and then conidia may germinate and penetrate out of alveoli into blood vessels to cause an invasive infection (31). For *A. flavus*, other sites of infections, e.g. cutaneous infections, rhinosinusitis, keratitis, usually occur in patients with skin or epithelial barrier defects, e.g. burn patients, long term corticosteroid usage, or immunocompromised patients (13, 15)

For virulence factors of *A. flavus*, it possesses many virulence factors similar to other *Aspergillus* species (13, 15). Extracellular proteinases, e.g. secreted aspartyl proteinase (SAP), serine proteinase (SP), metalloproteinase (MP), and alkaline proteinase, are common important virulence factors found in many *Aspergillus* species

including *A. flavus* for absorbing nutrients and playing a role in *A. flavus* infections (32-35). Aflatoxins cause a liver cancer in humans and they also inhibit neutrophil functions that may lead to an infection (36). For the pigments, they may play a role indirectly to protect the fungus from the environment, e.g. heat, UV light, pH, oxidative stress, free oxygen radicals (13, 15). However, the role of these virulent factors and other potential virulent factors in *A. flavus* still needs to be further investigated including both *in vitro* and *in vivo* models.

1.4 Diseases

Aspergillus species is a fungus that can be found in the environment. It can cause a wide variety of infections in humans, e.g. allergic bronchopulmonary aspergillosis, aspergilloma, invasive aspergillosis. Invasive aspergillosis form is the most invasive form and cause high morbidity and mortality rates in immunocompromised patients. This invasive aspergillosis form is mainly caused by an inhalation of *Aspergillus* conidia into the lungs, in which healthy people do not develop the disease but for people with immunosuppressive conditions, it can cause an invasive infection leading to high mortality rates.

The risk factors of invasive aspergillosis are organ transplantation receiving immunosuppressive agents, hematopoietic stem cell transplantation (HSCT), long-term

corticosteroid use, and AIDS (37, 38). In which most clinical symptoms are found in the lungs, therefore, resulting in a high risk of high mortality rate. The clinical manifestation of *Aspergillus species* is spread from the lungs to the bloodstream. The symptoms may not be specific, such as fever, cough, coughing up blood, or chest pain in the respiration, and can cause infection of various organs throughout the body (39, 40).

1.5 Diagnosis of invasive aspergillosis

The diagnosis of invasive aspergillosis uses the criteria set by the EORTC / MSG which is divided into a proven diagnosis, probable diagnosis, and possible diagnosis (Table 1) (41, 42).

Table 1. The diagnosis of invasive aspergillosis using EORTC/MSG
(38, 39, 42-44)

Diagnosis of invasive aspergillosis (EORTC/MSG)	Criteria for diagnosis
Proven diagnosis	<p><u>Microscopic analysis</u>: There will be a histopathological examination of tissue invading by septate hyphae into the body.</p> <p><u>Culture</u>:</p> <p>Sterile material: Recovery of a mold or “black yeast” by</p>

Diagnosis of invasive aspergillosis (EORTC/MSG)	Criteria for diagnosis
	<p>culture of a specimen obtained by a sterile procedure from a normally sterile and clinically or radiologically abnormal site consistent with an infectious disease process, excluding bronchoalveolar lavage fluid, a cranial sinus cavity specimen, and urine</p> <p>Blood: Blood culture that yields a mold such as <i>Fusarium species</i> in the context of a compatible infectious disease process.</p> <p>Serological analysis: CSF -> Not applicable</p> <p>PCR with sequencing from formalin-fixed paraffin-embedded tissue</p>
Probable diagnosis	<p><u>Host factors:</u> - Recent history of neutropenia (<500 neutrophils /mm³ for >10 days)</p> <ul style="list-style-type: none"> - Receipt of an allogeneic stem cell transplant - Prolonged use of corticosteroids at a dose of 0.3 mg/kg/day of prednisone equivalent for >3 weeks - Treatment with other recognized T or B cell immunosuppressants, such as cyclosporine, TNF-α blockers, specific monoclonal antibodies or nucleoside analogues during the past 90 days - Inherited severe immunodeficiency or acute graft-versus-host disease grade III or IV <p><u>Clinical criteria:</u> Patients must undergo a CT scan at least</p>

Diagnosis of invasive aspergillosis (EORTC/MSG)	Criteria for diagnosis
	<p>once and must show 1 in 4 of the following signs: A) Dense, well-circumscribed lesions(s) with or without a halo sign, B) Air-crescent sign, C) Cavity D) Wedge-shaped and segmental or lobar consolidation</p> <p><u>Mycological criteria:</u></p> <ul style="list-style-type: none"> - Direct test (cytology, direct microscopy, or culture): Mold in bronchoalveolar lavage fluid, sputum indicated by 1 of the following: <ul style="list-style-type: none"> a) Presence of fungal elements indicating a mold b) Recovery by culture of <i>Aspergillus</i> spp. - Indirect tests (detection of antigen or cell-wall constituents): The ELISA test was used to detect galactomannan in bronchoalveolar lavage fluid, plasma, CSF or serum and <i>Aspergillus</i> PCR.
Possible diagnosis	Host factor and clinical criteria without mycological criteria

1.6 Treatment of invasive aspergillosis

For the treatment recommendation in invasive aspergillosis, that is commonly used in primary therapy is voriconazole. Alternative therapy is liposomal amphotericin B (L-AMB), isavuconazole, amphotericin B lipid complex (ABLCL), amphotericin B,

posaconazole, itraconazole, caspofungin, micafungin, anidulafungin (45-48). In developing countries including Thailand, amphotericin B is often the first option to treat invasive aspergillosis due to socioeconomic status and drug availability (30, 49).

Amphotericin B is commonly used to treat many severe invasive fungal infections including invasive aspergillosis (50, 51). Mechanisms of action of amphotericin B are the binding property to ergosterol on the plasma membrane and increasing membrane permeability (52-54). There are four available formulations, i.e. amphotericin B deoxycholate (ABD), amphotericin B colloidal dispersion (ABCD), amphotericin B lipid complex (ABLC), and liposomal amphotericin B (LAMB) (50, 51, 55). Nephrotoxicity is a common side effect of ABD causing from a direct vasoconstrictive effect on afferent renal arterioles (56). This side effect is also depending on the dose of the drug (57). Wasting of potassium, magnesium, bicarbonate, and decreased erythropoietin production are also side effects of ABD. However, using lipid-associated formulations reduces these toxicities (58). Although the lipid-associated formulations have less undesirable side effects, the cost and the availability of the drug is still the problems for developing countries with poor socioeconomic status.

1.7 Antifungal resistance in *Aspergillus flavus*

Previously, the resistance mechanisms of the *Aspergillus* species have been studied. In most cases, there are the following resistance mechanisms, such as decreased drug concentrations, drug target alteration, and drug efflux (59). In this study, it was studied in *A. fumigatus* and *A. terreus* (60). In azole-resistant strain *A. fumigatus*, the mutation and overexpress of the *cyp51* gene is a gene resistant by *cyp51* encode to 14- α -sterol demethylase-ergosterol, which is the main component of the fungal cell wall (61). When the structure of 14- α -sterol demethylase changes, the drug will show reduced efficiencies due to the increased production of 14- α -sterol demethylase, changes in (+/- conformational changes). Additionally, the drug is reduced due to increased efflux pump activity (62). In *A. terreus*, which was found to be resistant to amphotericin B, it was found up-regulation of the synthesis of ergosterol gene (*ERG5*, *ERG6* and *ERG25*) which are resistant to amphotericin B (60). Furthermore, upregulation of oxidative stress response may play a major role in the amphotericin B resistance of *A. terreus* (63).

For *A. flavus* clinical isolates, MICs of these isolates to amphotericin B are usually two-fold higher than *A. fumigatus* clinical isolates and these results are also associated with clinical treatment failure (64-67). This is believed to be due to *A.*

flavus intrinsic resistance to amphotericin B (15). This intrinsic resistance was believed to be from an altered cell wall of *A. flavus*, higher alpha 1,3-glucan levels on the cell wall (15, 68). The result of this change was that amphotericin B may poorly penetrate into the fungus leading to decreased accumulation of amphotericin B inside *A. flavus* (68). Nevertheless, few studies were investigated in this *A. flavus* intrinsic resistance and further investigation needs to be done.

2. Trehalose pathway and fungal pathogens

Trehalose is a disaccharide from two glucose molecules, conjugated with α α -1,1-glycosidic linkage, found in both bacteria, plants, insects, and invertebrate, except mammals, including humans (69). Trehalose pathway is important in the pathogenesis of fungal pathogens such as *Candida albicans*, *Cryptococcus neoformans*, *Aspergillus fumigatus* (70-76). Trehalose is an important source of fungal energy, conidia survival and germination. It is responsible for the prevention of fungus from environmental conditions such as cold, heat, dryness, etc. (76-78)

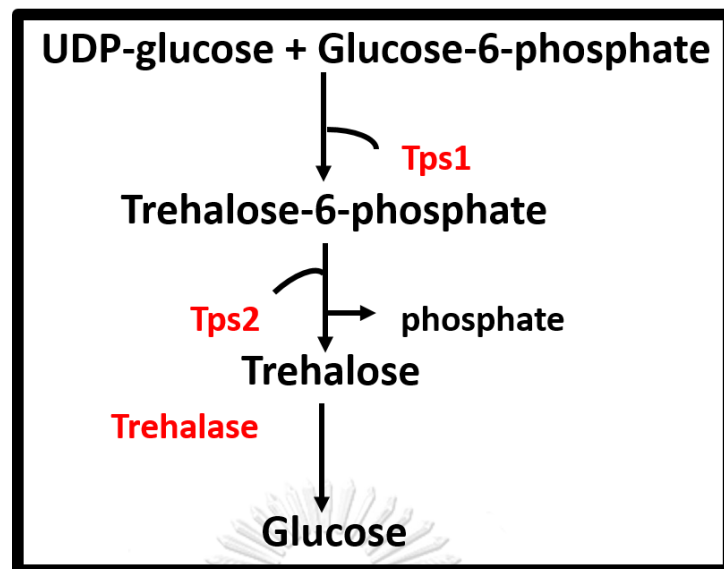

Figure 1. Trehalose metabolic pathway.

Trehalose, also known as a disaccharide from two glucose molecules, conjugated with α,α -1,1-glycosidic linkage, and giving in the formal name is α -D-glucopyranosyl-(1 \rightarrow 1)- α -D-glucopyranoside ($C_{12}H_{22}O_{11}$, anhydride). In addition, because the general energy of the glycosidic bond is thermodynamically and kinetically the most stable, it can help fungi survive at high temperatures, even under acidic conditions (79).

Trehalose biosynthesis in the fungus consists of five pathways (69, 70, 80). The first pathway is a common pathway found in bacteria, fungi, insect, and plants. It involves two enzymes, trehalose-6-phosphate synthase (Tps1) and trehalose-6-phosphate phosphatase (Tps2). Tps1 is the enzyme that changes UDP-glucose and glucose 6-phosphate into trehalose 6-phosphate (69). Tps2 is the enzyme that

removes phosphate from trehalose 6-phosphate to form trehalose (69) (Figure 1). The second pathway is the trehalose synthase found in bacteria. Which consists of the α 1- α 4 linkage of maltose into the α 1- α 1 linkage of trehalose (70, 81) (Figure 2A). The third pathway is related to change maltooligosaccharides to trehalose with the synthesis of trehalose are catalyzed by two enzymes, maltooligosyl trehalose synthase (TreY), leading to maltooligosyltrehalose and accelerating reaction with maltooligosyl trehalose trehalohydrolase (TreZ) into trehalose (70, 82) (Figure 2B). The fourth pathway is trehalose phosphorylase (TreP), an enzyme that transfers glucose to Glucose 1-phosphate and releases the remaining glucose to trehalose (83, 84) (Figure 2C). The fifth pathway involves trehalose glycosyl transferring synthase (TreT), an enzyme produced by accelerating the formation of trehalose reversed from ADP-glucose and glucose by trehalose glycosyl transferring synthase. In conclusion, TreT enzyme transfers glucose from ADP-glucose to trehalose (85) (Figure 2D).

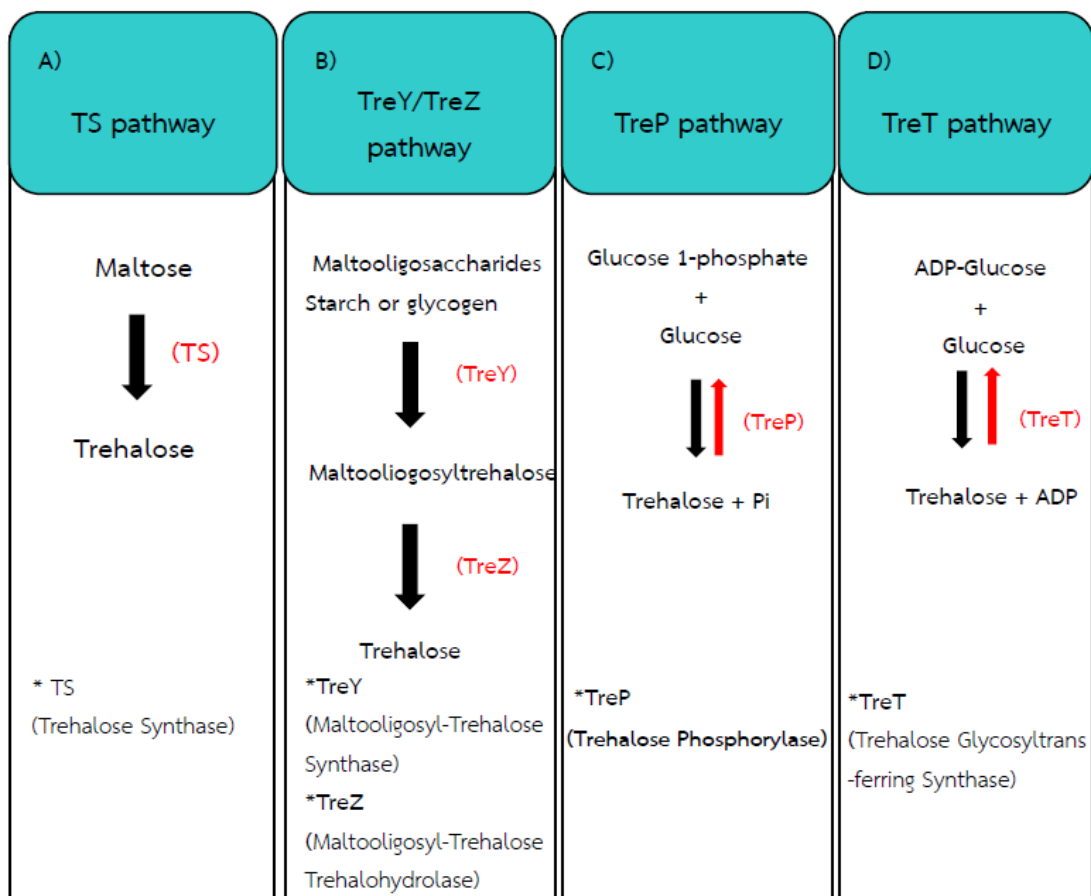

Figure 2. The trehalose biosynthetic pathways

(A) TS pathway, (B) TreY/TreZ pathway, (C) TreP pathway, (D) TreT pathway(80).

Trehalose is also an important element in the spores of fungi. Trehalose degradation is an important event at the beginning of germination and is assumed to act as a source of carbon for synthesis and glucose for energy (86). For example, in *Schizosaccharomyces pombe*, deletion of the neutral trehalase gene causes slow spore germination rates compared to wild type (87). It is also responsible for the prevention of fungi from environmental conditions such as cold, heat, dryness, etc. (76-78)

From many studies, they showed that the enzymes in trehalose pathway are important for the growth and pathogenesis of *Candida albicans*, *Cryptococcus neoformans*, *Aspergillus fumigatus* (76, 77). For example, in *Aspergillus fumigatus*, the mice were inoculated intranasally with wild type, $\Delta orlA$ (*TPS2* homolog) and *orlA* reconstituted strain of *Aspergillus fumigatus*. The results showed that mice infected with $\Delta orlA$ have a higher survival rate compared to mice that are infected with wild type and *orlA* reconstituted strain. It suggests that *orlA* affects the virulence of *Aspergillus fumigatus* (77). In *Aspergillus fumigatus*, the deletion of *tpsA/tpsB* gene (*TPS1* homolog) had an effect of delayed conidial germination at 37°C. This study showed that the deletion of *tpsA/tpsB* gene was important for spore germination and heat stress (76).

In *Candida albicans*, lack of *Tps1* affected the normal growth at 37°C and under other stress conditions, including decreased virulence in mouse models (75). In *Cryptococcus neoformans*, the deletion of *tps1* affected the survival of mice in murine inhalational cryptococcosis with H99 (wild type strain) model (72). In *Cryptococcus gattii*, the *tps1* deletion mutant reduced virulence in both murine and *Caenorhabditis elegans* models (88).

Lack of Tps2 protein in *Candida albicans*, *Cryptococcus gattii* and *Aspergillus fumigatus*, the growth of the fungi decreased at temperatures above 37°C and decreased virulence in mouse models (72, 76, 88). For example, in *Candida albicans*, *tps2*Δ/*tps2*Δ strain was resistant to stress tolerance growth and decreased the growth at a temperature of 44°C compared to wild type and heterozygous strain (74). In mouse models, mice infected with *tps2*Δ/*tps2* Δ strain had a higher survival rate compared to wild type and heterozygous strain (74). In *Saccharomyces cerevisiae*, disruption of the *TPS2* gene caused temperature-sensitive growth by stopping the growth at 40 °C (89).

There are also other targets in the trehalose pathway which are regulatory subunits. In *Saccharomyces cerevisiae* has two additional proteins in the complex (Tps3p/Tsl1p) (90). Tps3p is a regulatory subunit of trehalose-6-phosphate and trehalose-6-phosphate phosphatase. There are involved in the synthesis and storage of trehalose. The expression is caused by stress conditions (90). Tsl1p is a large subunit of this regulatory subunit and it contributes to survival of fungi from heat stress (90, 91). In fungi without *TPS3* and *TSL1*, they could not grow at high temperatures (90, 91). Furthermore, lack of both *TPS3* and *TSL1* affected trehalose synthase activity (90, 91).

3. Trehalase enzymes

In addition to Tps1p and Tps2p, trehalase is a trehalose hydrolyzing enzyme responsible for degrading trehalose into two glucose molecules (92). There are two types of trehalase found in *Saccharomyces cerevisiae* (93), which are neutral trehalase and acid trehalase (Figure 3). Neutral trehalase (Nth1p) found in cytosol and Nth1p worked at an optimum pH of 7.0 (92, 94). Acid trehalase (Ath1p) found in the vacuole and worked at an optimum pH of 5.0 (95-97).

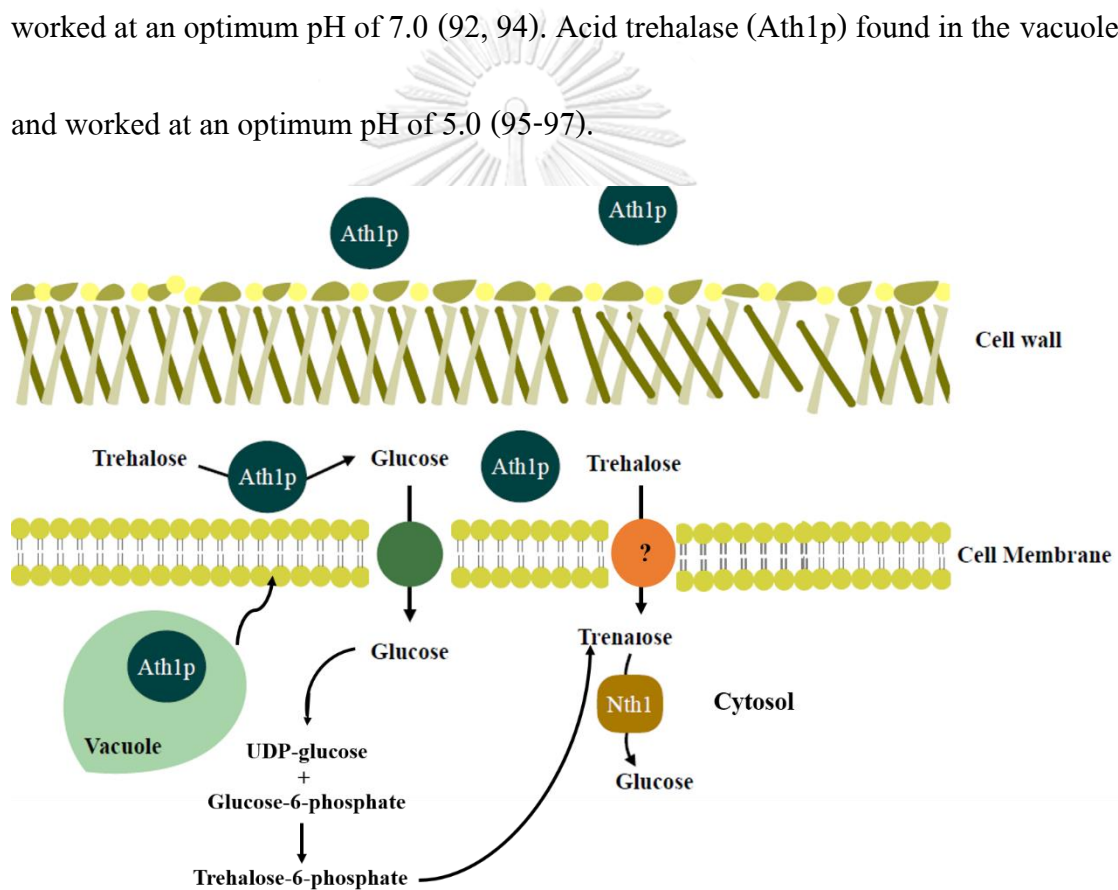

Figure 3. Localization of trehalase enzymes

The pathway is shown on the localization of acid trehalase and neutral trehalase.

(Ath1p: acid trehalase, Nth1p: neutral trehalase)

Trehalase enzyme in fungi is important for virulence in mouse models and survival under the heat stress. For example, in *Candida albicans*, deletion of acid trehalase gene showed more survival in the mouse model compared to other strain (98). In *Aspergillus niger*, they performed the heat stress experiment with *Aspergillus niger* trehalase-deletion mutant at 55 °C at different time-points. At 40 minutes, *Aspergillus niger* trehalase-deletion mutant showed less CFU, compared to the wild type and the complement strains. This study showed that the deletion of the trehalase gene is important for the survival of *Aspergillus niger* under heat stress (99).

4. Validamycin A and fungal pathogens

There is a trehalase inhibitor, called validamycin A (100-102) (Figure 4A-B). Originally, validamycin A was first used to inhibit *Rhizoctonia solani*, rice fungal pathogen (102). It was shown to inhibit the branching of this fungus at the concentration of 200 $\mu\text{g/mL}$ (102, 103). Moreover, validamycin could inhibit conidial production of *Fusarium culmorum* at the concentration of 100 μM (103).

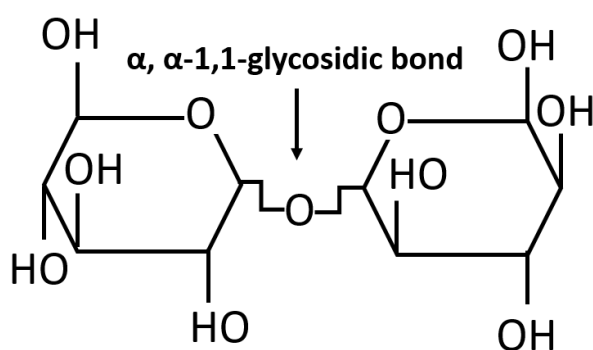

A: Trehalose structure

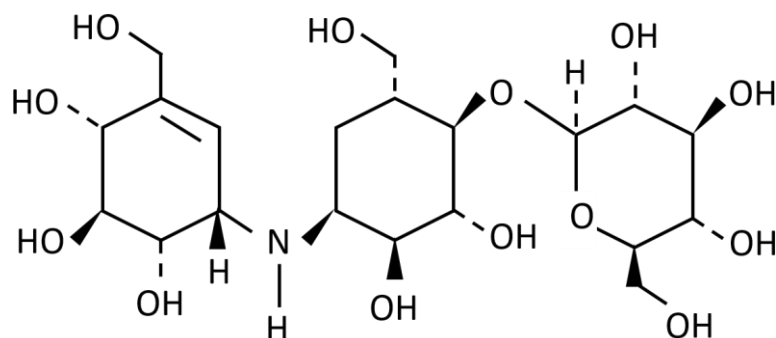

B: Validamycin A

Figure 4. Structure of trehalose and validamycin A.

(A) Structure of trehalose. (B) Structure of validamycin A. It is used as an inhibitor of trehalase. Validamycin A is a competitive inhibitor of trehalase enzyme.

For human fungal pathogens, validamycin A at 0.1 mg / mL significantly inhibited the growth of *Candida albicans* (104). Additionally, validamycin A was not irritating to the skin of rabbits (105). In 90-day feeding trials of validamycin A, rats receiving 1000 mg/kg/day and mice receiving 2000 mg/kg-day showed no toxic effects (105). However, there is still limited data on the effectiveness of validamycin A on other fungal pathogens, including *Aspergillus flavus*. Although there were some studies on the toxicity of validamycin A, it has never been performed in human cell lines. Therefore, the effectiveness against other fungal pathogens and the toxicity to humans are still unclear. Thus, the main objective of this study is to understand the effect of validamycin A on the growth of *A. flavus* and to study the combinative effect

of validamycin A and amphotericin B together while evaluating the toxic effect of validamycin A to human cell lines.



CHAPTER III MATERIALS AND METHODS

1. Fungal strain, media, and conditions

Aspergillus flavus ATCC 204304 was cultured on Sabouraud Dextrose Agar (SDA, Oxoid, Thermo Fisher Scientific) at 37°C for three days before harvesting using sterile distilled water with 0.01% tween 80. Briefly, 5 mL of sterile distilled water with 0.01% tween 80 was utilized to harvest *A. flavus* on SDA petri-dish plates using cell scrapers. The mixture between distilled water and *A. flavus* spores was filtered using miracloth. A number of spores were counted from filtrate using a hemocytometer. Then, 10³ spores were inoculated into each culture medium (106): glucose peptone agar (peptone 10 g, glucose 20 g, agar 20 g, distilled water 1000 ml, pH 6.8–7.0), trehalose peptone agar (peptone 10 g, trehalose 10 g, agar 20 g, distilled water 1000 ml, pH 6.8–7.0), and peptone agar (peptone 10 g, agar 20 g, distilled water 1000 ml, pH 6.8–7.0), at 37°C for 2 and 5 days to measure the radial growth of these fungal growths on days 2 and 5. This experiment was performed in a biological triplicate manner. *A. flavus* strains from 20 clinical isolates from patients (sinus, sputum, skin, nail, including sterile sites) and ATCC204304 were utilized and all the isolates were stored in the stock - 80 °C. All clinical isolates were obtained from the Department of Microbiology, Faculty of Medicine, Chulalongkorn University and King Chulalongkorn Memorial Hospital in 2019. Patient characteristics were retrieved from King Chulalongkorn Memorial Hospital records. Patients with invasive aspergillosis (IA) were classified as proven, probable, and possible invasive aspergillosis, according to EORTC/MSG criteria (41).

2. Trehalose measurement

To study trehalose levels of *Aspergillus flavus* ATCC 204304, spores from 5-day cultures in Sabouraud dextrose media and trehalose peptone media in the media with or without 1 $\mu\text{g}/\text{mL}$ validamycin A were collected. Trehalose levels were measured from *A. flavus* conidia, as previously described (107). Briefly, 2×10^8 conidia were boiled at 100°C for 20 minutes and cell-free extracts were obtained from centrifuging at $11,000\times g$ for 10 minutes. The supernatant was used to measure trehalose levels using the glucose oxidase assay protocol (Sigma; GAGO20). These tests were performed in biological triplicates.

3. Germination assay

1×10^8 spores of *Aspergillus flavus* ATCC 204304 were collected and incubated in 10 mL Sabouraud dextrose broth at 37°C in an orbital shaker at 200 rpm (Forma Orbital Shaker, Thermo Scientific, USA). 500 μL of each culture was used for counting germling percentage at each time point. Each strain was cultured for 24 hours at 37°C in three biological replicates (108).

4. XTT assay

To measure the metabolic activity and viability of *Aspergillus flavus* ATCC 204304 after incubating with validamycin A, XTT assays (sodium 2,3-bis (2-methoxy-4-nitro-5-sulfophenyl) -5- [(phenylamino) -carbonyl] -2H-tetrazolium) were performed (109, 110). Briefly, 10^3 spores of *A. flavus* ATCC 204304 were incubated with different culture media or with validamycin A for 18 hours at 37°C. XTT solution (0.5 mg/mL in PBS) was added to each well, and the plate was further incubated for 15 minutes at 37°C. Then, the plate was centrifuged, and the supernatant was collected to measure the OD at 490nm using a spectrophotometer (Lambda 1050+ UV/Vis/NIR, PerkinElmer, USA).

5. Broth microdilution assay and checkerboard assay

The CLSI broth microdilution M38 method was performed to observe the minimum inhibitory concentrations (MICs) of amphotericin B in *Aspergillus flavus* ATCC 204304 and clinical isolates (111). After that, the additive/synergistic effect of validamycin A and amphotericin B was studied using the checkerboard assays (112). To determine the additive and synergistic effect, the fractional inhibitory concentration index (FICI) was calculated for each antifungal drug in each combination using the following formula (112): $FIC_A (MIC_A/MIC_{A+B}) + FIC_B (MIC_B/MIC_{A+B}) = FICI$ and

the following FICI results were determined as synergy: <0.5 ; additivity: $0.5-1$; indifference: $>1-4$; and antagonism: >4 .

6. Time-kill kinetics assay

10^3 spores of *A. flavus* with high amphotericin B (AMB) MIC strains were prepared, and liquid cultures in Sabouraud dextrose broth were performed at a concentration of $0.5 \times \text{MIC}$ from validamycin A ($0.125 \mu\text{g/ml}$) and amphotericin B ($2 \mu\text{g/ml}$). Cultures were placed on the shaker at 200 rpm and incubated at 37°C . At each time point (4, 8, 12, 24, and 48 h), 100 μl of cultures was plated on SDA plates at 37°C for 48 h. The time-killing curves were determined by a count of colony-forming units (CFU/mL), at each time point (113-115).

7. Cell lines and culture

BEAS-2B (Human bronchial epithelial cell line) (ATCC[®] CRL9609[™]) was cultured in bronchial epithelial cell growth media, and tissue culture flasks were coating using 0.01 mg/mL fibronectin, 0.03 mg/mL bovine collagen type I, and 0.01 mg/mL bovine serum albumin (BSA) dissolved in the culture medium. Cell cultures were incubated at 37°C in a humidified environment with 5% CO_2 (116).

8. Cytotoxicity assay

The cytotoxicity test was performed to observe the toxicity of validamycin A to human epithelial cell lines using Lactate Dehydrogenase (LDH)-Cytotoxicity Colorimetric Assay Kit II (Biovision Inc, CA, USA). Briefly, 1×10^4 BEAS-2B cells were incubated with 50 μ l of DMEM in a pre-coating 96-well plate and then validamycin A will be added at the different concentrations (1 μ g/mL - 1mg/mL), for each time point. LDH reaction mixture was added and incubated at 37°C for 30 minutes. Then ODs were measured at 450 nm using a spectrophotometer. Later, the percentage of the cytotoxicity was calculated using the following formula:

$$\text{Cytotoxicity (\%)} = \frac{(\text{test sample} - \text{low control}) \times 100}{(\text{high control} - \text{low control})}$$

Test sample: cell lines with media and test sample

Low control: cell lines with media alone

High control: cell lines with media and 10 % lysis solution

9. Statistical analysis

All statistical analyses were conducted with Prism 8 software (GraphPad Software, Inc., San Diego, CA). Error bars represent standard errors of the means. Student's t-test for differences and *, P -value < 0.05; **, P -value < 0.01; ***, P -value < 0.001 showed that the difference was statistically significant.

10. Ethics statement

This study has been approved by the Institutional Review Board (IRB No. 546/60),

Faculty of Medicine, Chulalongkorn University, Bangkok, Thailand.



CHAPTER IV RESULTS

1. Trehalase homologs exist in *Aspergillus flavus*

To identify *Aspergillus flavus* trehalase enzyme homologs, a BLASTp search was performed on the *Saccharomyces cerevisiae* and *Aspergillus fumigatus* compared to *Aspergillus flavus*. We compared the protein data using FungiDB database and Simple Modular Architecture Research Tool (SMART) to compare the putative protein domain of trehalase proteins in *S. cerevisiae* (*Sc*), *A. fumigatus* (*Afu*), *A. flavus* (*Afla*) (Database: <https://fungidb.org>, <http://smart.emblheidelberg.de/>). AFLA_090490 protein possesses one signal peptide at positions 1-18 and two O-glycosyl hydrolase domains (EC 3.2.1) at positions 70-339 and positions 407-638, which are similar to *S. cerevisiae* and *A. fumigatus* acid trehalase proteins (Figure 5A). In addition, AFLA_052430 protein possesses a neutral trehalase calcium binding domain at positions 105-134 and an O-glycosyl hydrolase domain (EC 3.2.1) at positions 162-725 similarity to *S. cerevisiae*, *A. fumigatus* neutral trehalase proteins (Figure 5B). From these data, it suggests that *A. flavus* has at least two trehalase enzymes similar to *S. cerevisiae* and *A. fumigatus*.

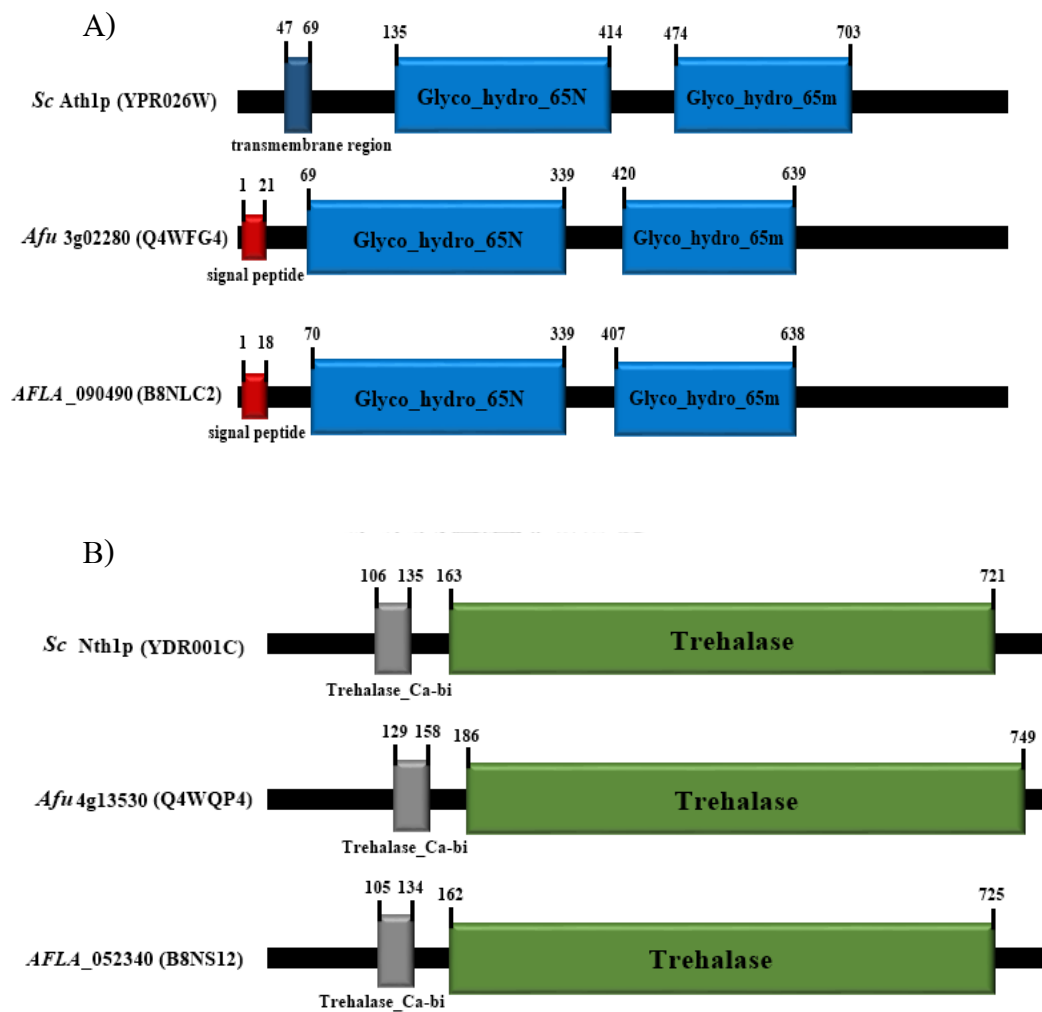

Figure 5. *Aspergillus flavus* possesses trehalase homologs.

A) From BLASTp analyses, percentages of identity and similarity of *ScAth1p* (YPR026W) : *AFLA_090490* (B8NLC2) and *Afu3g02280* (Q4WFG4) : *AFLA_090490* (B8NLC2) are identity (29%), similarity (46%) and identity (68%),

similarity (81%), respectively. *ScAth1p*: *Saccharomyces cerevisiae* acid trehalase protein; *Afu*: *Aspergillus fumigatus*; *AFLA*: *Aspergillus flavus*; Glycosyl hydrolase family 65 (Glyco_hydro_65N; Glyco_hydro_65m). (Adapted from SMART analyses (<http://smart.embl-heidelberg.de/>)).

B) From BLASTp analyses, percentages of identity and similarity of *ScNth1p* (YDR001C) : AFLA_052438 (B8NS12) and *Afu*4g13530 (Q4WQP4) : AFLA_052438 (B8NS12) are identity (55%), similarity (69%) and identity (81%), similarity (88%), respectively. *ScNth1p*: *Saccharomyces cerevisiae* neutral trehalase protein; *Afu*: *Aspergillus fumigatus*; *AFLA*: *Aspergillus flavus*; Trehalase_Ca-bi: Neutral trehalase calcium binding domain; Trehalase: Trehalose hydrolysis domain. (Adapted from SMART analyses (<http://smart.embl-heidelberg.de/>)).

จุฬาลงกรณ์มหาวิทยาลัย
CHULALONGKORN UNIVERSITY

To study the ability of *A. flavus* to utilize trehalose as a sole carbon source, *A. flavus* was grown on trehalose peptone media, which contained trehalose as a sole carbon source. The radial growth and viability of *A. flavus* ATCC204304 was then measured. As a result, we observed that the growth of *A. flavus* on glucose peptone media and trehalose peptone media was similar compared to peptone media alone (Figure 6A). Furthermore, the viability of *A. flavus* on glucose peptone media and

trehalose peptone media using XTT assays was also similar compared to peptone media alone (Figure 6B). These data supports that *A. flavus* utilizes trehalose as a sole carbon source, which implies that *A. flavus* degrades extracellular trehalose into glucose for the growth of the fungus, possibly using trehalase enzymes.

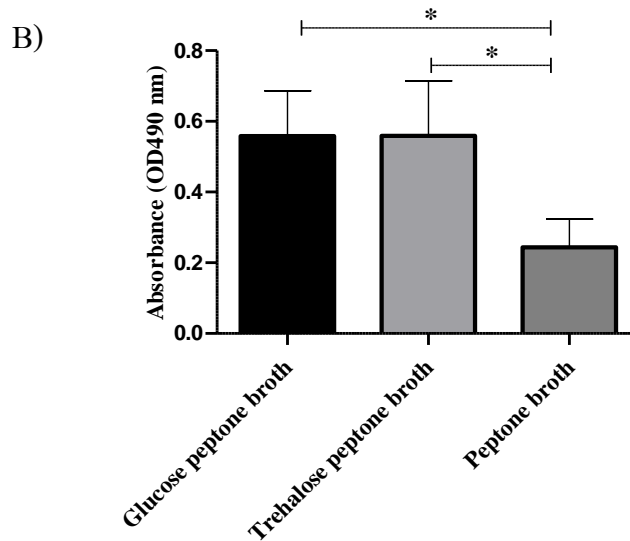
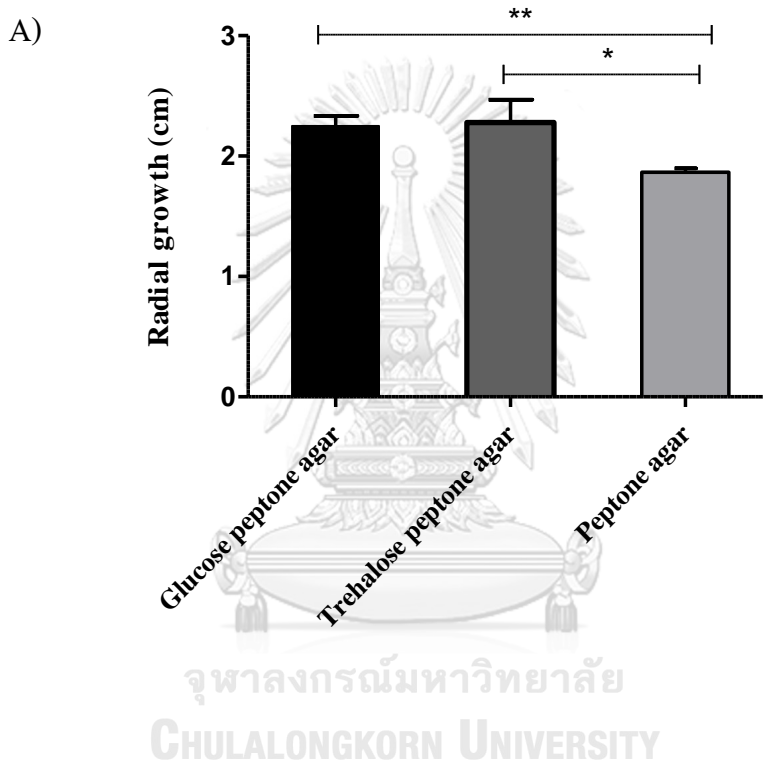

Figure 6. *Aspergillus flavus* utilizes trehalose as a sole carbon source similar to glucose.

A) *Aspergillus flavus* ATCC 204304 was incubated at 37°C on glucose peptone, trehalose peptone, and peptone alone media. The radial growth of these fungal growths was measured on the second day. Data are presented as means \pm SE from three biological replicates. *, P -value < 0.05; **, P -value < 0.01 (unpaired two-tailed Student's t -test compared to the peptone media control). B) *Aspergillus flavus* ATCC 204304 was incubated at 37°C on glucose peptone, trehalose peptone, and peptone alone liquid media for 24 hours. The viability tests using XTT assays were performed. Data are presented as means \pm SE from three biological replicates. *, P -value < 0.05 (unpaired two-tailed Student's t -test compared to the peptone media control).

จุฬาลงกรณ์มหาวิทยาลัย
CHULALONGKORN UNIVERSITY

2. Validamycin A inhibits the growth of *Aspergillus flavus* and increases conidial trehalose levels with delayed conidial germination

From previous experiments, we found that *A. flavus* possessed trehalase enzymes from the BLAST and SMART search and it utilized these trehalase enzymes to digest extracellular trehalose in the trehalose peptone media. Next, we utilized validamycin A, a trehalase inhibitor, to observe the minimal inhibition concentration (MIC) of

validamycin A against *A. flavus* ATCC 204304 using broth microdilution assays. We observed that MIC of validamycin A against *A. flavus* was at 1 $\mu\text{g}/\text{mL}$ (Table 2).

Next, to observe the effect of validamycin A at the concentration of 1 $\mu\text{g}/\text{mL}$ on the viability of *A. flavus* ATCC204304 using XTT assays, we observed that validamycin A inhibited the viability of *A. flavus* ATCC 204304 significantly at 1 $\mu\text{g}/\text{mL}$ compared to validamycin A at 0.5 $\mu\text{g}/\text{mL}$ and amphotericin B at 0.25 $\mu\text{g}/\text{mL}$ (Figure 8A).

To observe the effect of validamycin A on trehalose levels, we grew *A. flavus* ATCC 204304 in Sabouraud dextrose media and trehalose peptone media with or without 1 $\mu\text{g}/\text{mL}$ validamycin A and collected conidia of each group to measure trehalose levels in the conidia. We observed that conidia collected from validamycin A-contained media had higher trehalose levels than conidia from control media significantly (Figure 8B). This result suggests that validamycin A inhibits trehalase enzymes in the conidia leading to increased trehalose levels. In trehalose peptone media, overall conidial trehalose level was decreasing. However, there was no difference in trehalose level of conidia from trehalose peptone media with or without validamycin A (Figure 8C). This result suggests that there may be a trehalose

transporter and validamycin A has a major inhibitory effect on acid trehalase but partially inhibits neutral trehalase (Figure 7). Therefore, with the supplementation of trehalose in the media, trehalose level inside conidia would not increase as much as in the glucose media in the presence of validamycin A.

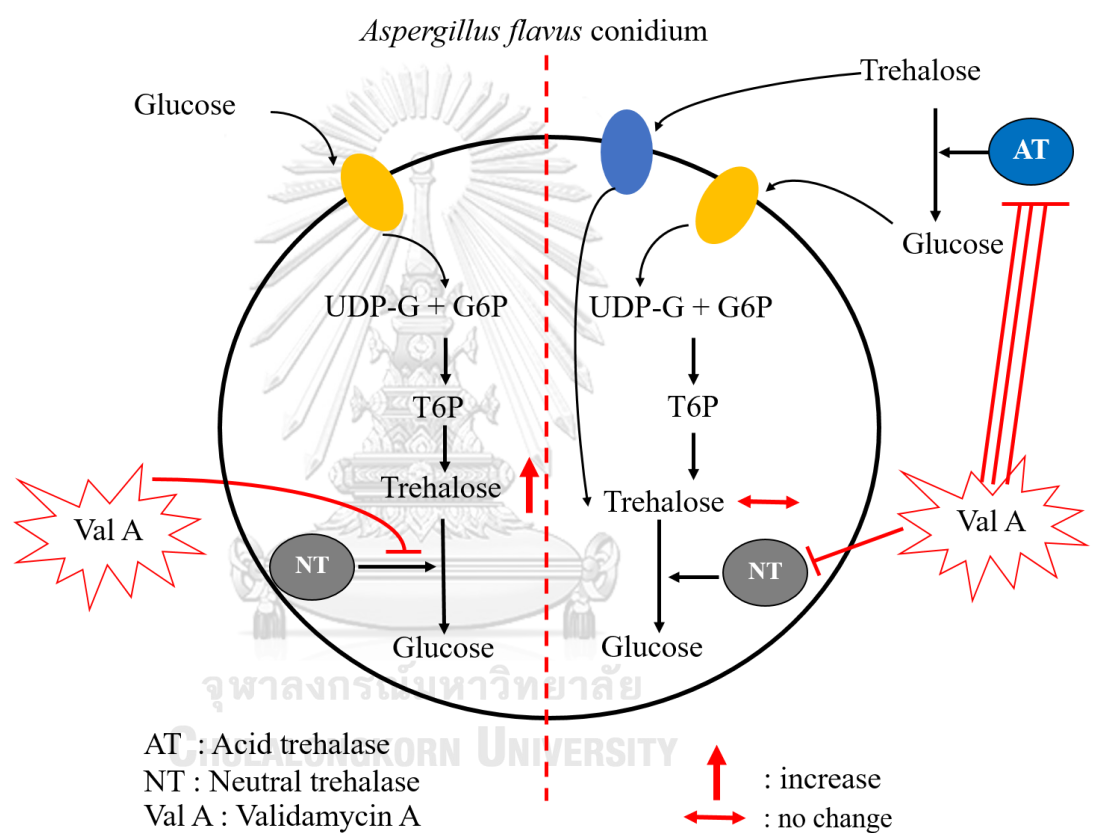
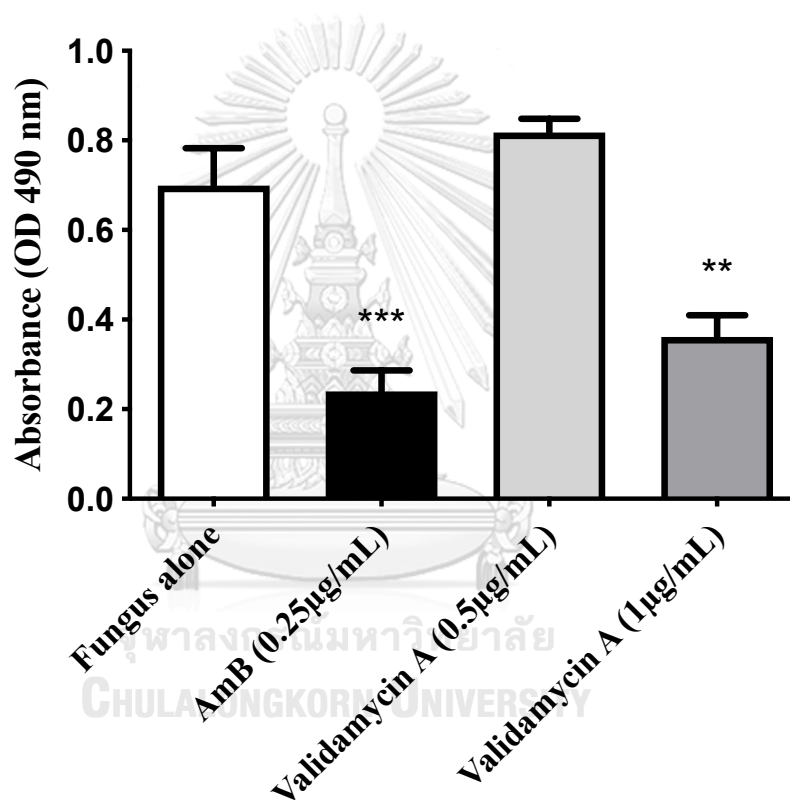

Figure 7. The hypothesis of the mechanism of validamycin against acid trehalase and neutral trehalase.

To further study the effect of validamycin A behind the decreased growth of *A. flavus*, we performed germination assays to observe the rate of conidial germination in the presence of 1 $\mu\text{g/mL}$ validamycin A. We observed that validamycin A delayed the

conidial germination of *A. flavus* ATCC 204304 significantly at 10 hours and 12 hours (Figure 8D). This data suggests that the effect of validamycin A on trehalase enzymes results in delayed conidial germination.

A)



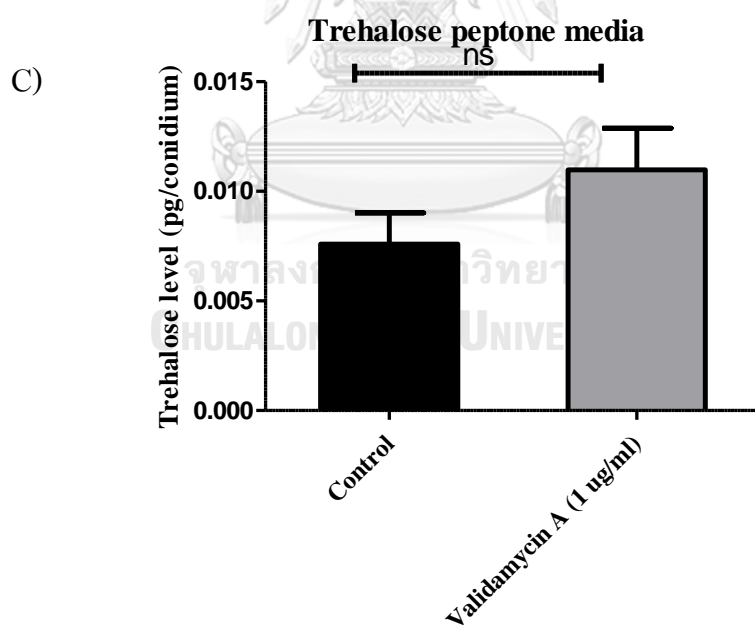
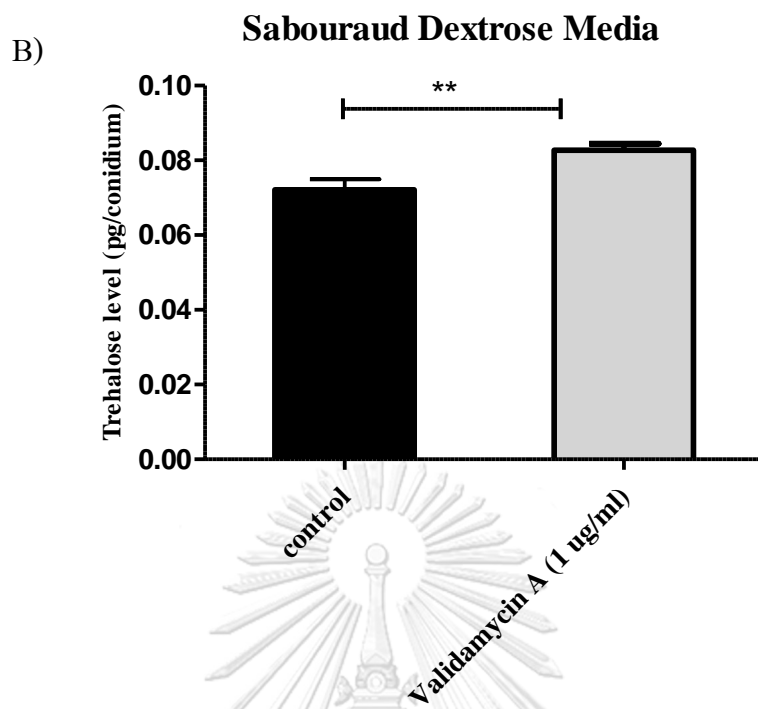

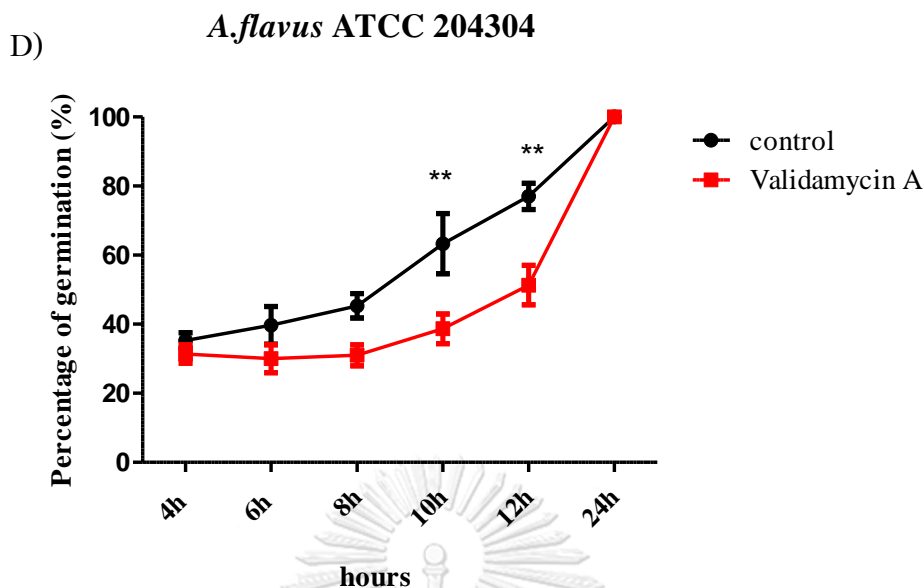

Figure 8. Validamycin A inhibits the growth and increases trehalose level in *Aspergillus flavus* conidia with delayed conidial germination.

A) *Aspergillus flavus* ATCC204304 was cultured at 37°C on RPMI media in 24-well plate for 18 hours. Fungal viability was measured by XTT assays at 490 nm. Unpaired t-test was used to compare the fungal growths. Amp: Amphotericin B at 0.25 µg/mL, Data are presented as means ± SE from three biological replicates. *, *P*-value < 0.05; **, *P*-value < 0.01; ***, *P*-value < 0.001 (unpaired two-tailed Student's *t*-test compared to the control or amphotericin B). B) *Aspergillus flavus* ATCC 204304 was cultured at 37°C on Sabouraud dextrose agar for five days with or without 1 µg/mL validamycin A. Trehalose assays were performed to measure trehalose levels in the conidia using glucose oxidase assays. Data are presented as means ± SE from three biological replicates. **, *P*-value < 0.01 (unpaired two-tailed Student's *t*-test compared to the control). C) *Aspergillus flavus* ATCC 204304 was cultured at 37°C on trehalose peptone agar for five days with or without 1 µg/mL validamycin A. Trehalose assays were performed to measure trehalose levels in the conidia using

glucose oxidase assays. Data are presented as means \pm SE from three biological replicates. ns: no significance (unpaired two-tailed Student's *t*-test compared to the control). D) *Aspergillus flavus* ATCC 204304 was cultured at 37⁰C in Sabouraud dextrose broth with or without 1 μ g/mL validamycin A in an orbital shaker at 200 rpm. Spore germination at each time point was counted and calculated. Data are presented as means \pm SE from three biological replicates. **, *P*-value < 0.01 (unpaired two-tailed Student's *t*-test compared to the control).

3. Validamycin A has a synergistic effect with amphotericin B in *A. flavus* clinical isolates with high MICs of amphotericin B

Next, we hypothesize that validamycin A may have a combination effect with antifungal agents, amphotericin B. To test our hypothesis, the antifungal susceptibility assays of *A. flavus* ATCC 204304 was performed to find minimum inhibitory concentrations (MICs) according to the CLSI broth microdilution method, CLSI M38 (2017). The results showed that the MIC of amphotericin B against *A. flavus* ATCC 204304 was at 4 μ g/mL (Table 2). Furthermore, checkerboard assays were performed to observe the combination effect between validamycin A and amphotericin B. The fractional inhibitory concentration index (FICI) was calculated for validamycin A and amphotericin B in each combination. As a result, the additive effect between validamycin A and amphotericin B was observed with the FICI at 0.625 in *A. flavus*

ATCC204304. The MICs in the combination of validamycin A and amphotericin B were at 0.125 $\mu\text{g}/\text{mL}$ and 2 $\mu\text{g}/\text{mL}$, respectively (Table 2).

Additionally, three *A. flavus* clinical isolates with high MICs of amphotericin B, which were higher than Epidemiological Cutoff Value (ECV) of amphotericin B in *A. flavus* (4 $\mu\text{g}/\text{mL}$) (Table 2), were chosen to perform checkerboard assays to observe the combination effect of validamycin A and amphotericin B. All isolates came from the lower respiratory tract including the sinus cavity with the diagnosis of invasive aspergillosis (Table 2). None of these patients had exposure to amphotericin B before. Interestingly, the FICI of validamycin A and amphotericin B of these clinical isolates was about 0.25-0.28 with synergistic effects (Table 2).

Table 2. Patient characteristics and fractional inhibitory concentration index (FICI) of *Aspergillus flavus* clinical isolates with high amphotericin B minimum inhibitory concentrations (MICs) (Interpretation: A: additive; S: synergistic)

<i>A. flavus</i> strains	Specimen	Diagnosis	MICs of single agent alone (µg/mL)			MICs of combined agents (µg/mL)		FICI (µg/mL)	Interpretation
			Validamycin A	Amphotericin B	Amphotericin B	Validamycin A	Amphotericin B		
(ECV, µg/mL)				4					
ATCC204304	Human sputum		1	4		0.125	2	0.625	A
<i>A. flavus</i> SI 1	Invasive aspergillosis at left sphenoid sinus; sinus tissue	Diabetes, hypertension, dyslipidemia	>128	8		0.125	2	<0.251	S
<i>A. flavus</i> SP 2	Invasive pulmonary aspergillosis; sputum	Hepatitis C virus cirrhosis	1	8		0.0312	2	0.281	S
<i>A. flavus</i> EN 3	Invasive pulmonary aspergillosis; endotracheal aspirate	Acute lymphoblastic leukemia	>128	8		0.0039	2	<0.250	S

A. flavus EN 3

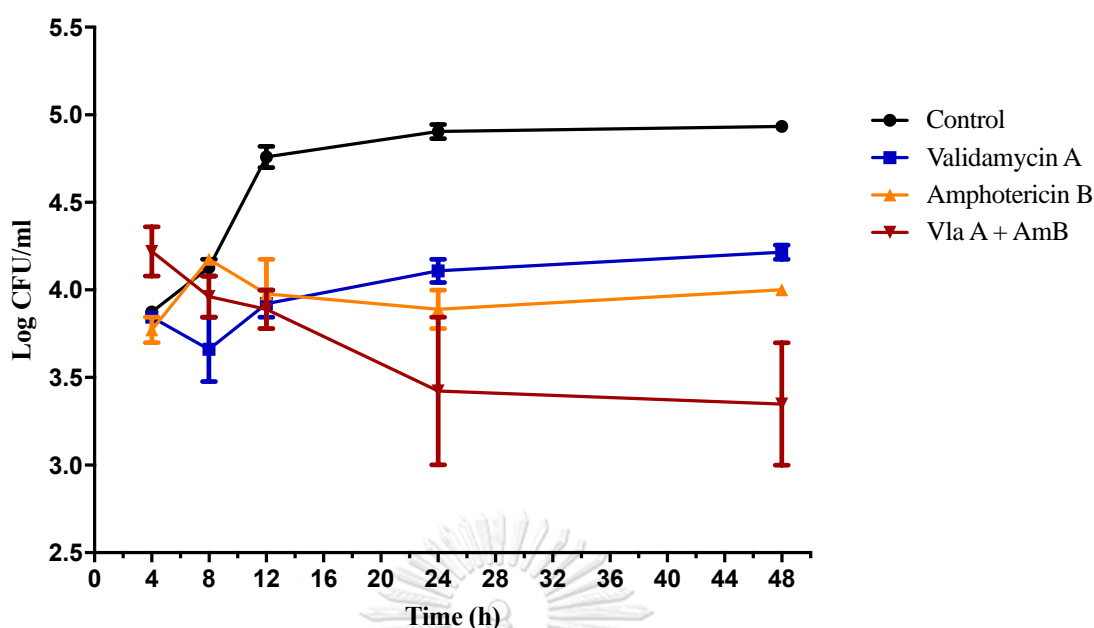

Figure 9. Validamycin A has a synergistic effect with amphotericin B against *A. flavus* clinical isolates.

10^3 spores of *A. flavus* with high amphotericin B (AMB) MIC strain was incubated at a concentration of $0.5 \times$ MIC of validamycin A ($0.125 \mu\text{g/mL}$) and amphotericin B ($2 \mu\text{g/mL}$). The *A. flavus* clinical isolate was then exposed to no drug (control, black circle), validamycin A at $0.125 \mu\text{g/mL}$ (blue square), amphotericin B at $2 \mu\text{g/mL}$ (yellow triangle), the combination of validamycin A at $0.125 \mu\text{g/mL}$ and amphotericin B at $2 \mu\text{g/mL}$ (red triangle).

These synergistic effects were again confirmed by time-kill assays (Figure 9).

The effect of inhibiting the growth of the *A. flavus* clinical isolate was at the peak at 48 hours between the control and the combination of amphotericin B and validamycin A, and the amount of colony-forming units was significantly different at $2 \log_{10}$ decreases in CFU /ml between the control and the combination of amphotericin B and validamycin A.

4. Validamycin A has no cytotoxicity to human bronchial epithelial cells

To observe the toxicity of validamycin A on human bronchial epithelial cells, BEAS-2B, we performed LDH cytotoxicity assays using LDH-Cytotoxicity Colorimetric Assay Kit II. The results showed that 0.125 $\mu\text{g/mL}$ of validamycin A, 2 $\mu\text{g/mL}$ of amphotericin B, and the combination of validamycin A and amphotericin B did not cause significant toxicity to human bronchial epithelial cells (Figure 10).

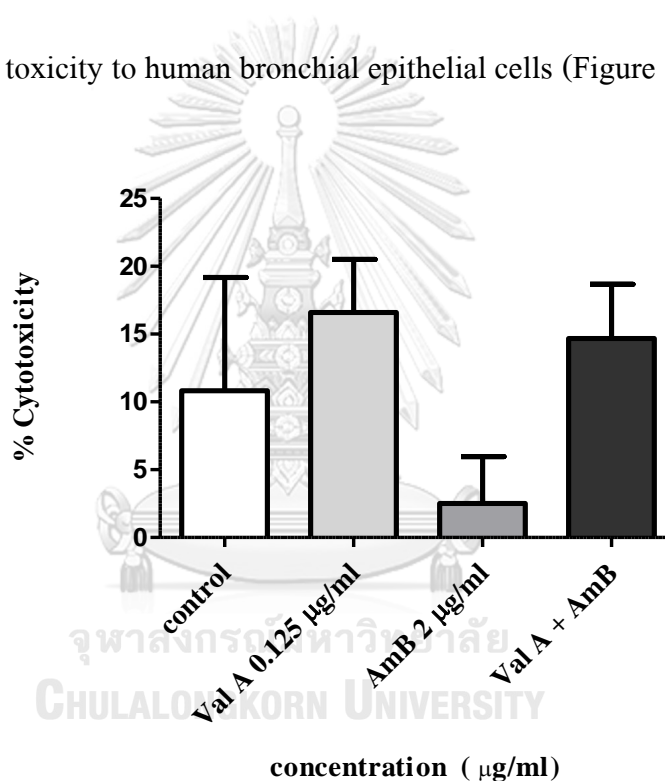

Figure 10. Validamycin A and the combination of validamycin A and amphotericin B have no cytotoxic effect on human bronchial epithelial cells.

The cytotoxicity test was performed to observe the toxicity of validamycin A on BEAS-2B using lactate dehydrogenase (LDH)-Cytotoxicity Colorimetric Assay Kit II.

Cell cultured were incubated at 37°C in a humidified environment containing 95% air-5% CO₂. After 24 hours, Using LDH reaction mixture was added for the volume of 25 µl, incubated at 37°C for 30 minutes. Then ODs were measured at 450 nm using a spectrophotometer. Data are presented as means \pm SE from three biological replicates. There was no statistical significance (unpaired two-tailed Student's t-test compared to the control).



CHAPTER V DISCUSSION AND CONCLUSION

Trehalose pathway is apparently important for the growth and pathogenesis of pathogenic fungi while the significance of trehalase enzymes in pathogenic fungi is still unclear (70-76). Our study utilized a trehalase inhibitor, validamycin A, to study the effect on the growth and the combinative effect on amphotericin B against a pathogenic fungus, *Aspergillus flavus*. Validamycin A is firstly produced by *Streptomyces hygroscopicus* (117, 118). It is a trehalase inhibitor of fungi, plants, and insects (100-102). Validamycin A was previously demonstrated to inhibit the growth of *Rhizoctonia solani*, rice fungal pathogen, and *Fusarium culmorum* (102, 103). For human fungal pathogens, *Candida albicans*, validamycin A at 0.1 mg/mL inhibited growth significantly compared to amphotericin B and controls (104).

In this study, *A. flavus* possessed trehalase homologs compared to *Saccharomyces cerevisiae* and *Aspergillus fumigatus*. We observed that *A. flavus* was able to grow on trehalose peptone media similar to glucose peptone media (Figure 6A, B). These results support that *A. flavus* has trehalase enzymes for utilizing trehalose as a sole carbon source. To further observe the effect of validamycin A, which inhibits trehalase enzymes, on the growth of *A. flavus*, we utilized XTT assays to observe the

growth of *A. flavus*. We found that validamycin A decreased the growth of *A. flavus* significantly (Figure 8A). These results imply indirectly that trehalase activity is important for *A. flavus*. Nevertheless, further genetic approaches, i.e., generating trehalase gene-deletion mutants, is crucial to discover the function and importance of trehalase enzymes in *A. flavus*.

Validamycin A was reported to increase trehalose levels in a pathogenic fungus, *Candida albicans* (104). We also observed similar results that validamycin A was able to increase trehalose levels of *A. flavus* conidia (Figure 8B). However, the trehalase activity assay is also necessary to confirm the effect of validamycin A. Trehalose pathway is vital for conidial germination (76, 77, 119). Normal trehalose metabolism helps the early stages of the conidial germination process (86). Therefore, the disruption of enzymes in the trehalose pathway affects conidial germination. We further observed similar effects from the inhibition of trehalase enzymes using validamycin A that *A. flavus* conidia in the presence of validamycin A delayed germination at 10-12 hours (Figure 8C). Furthermore, inhibition of trehalase enzymes in the trehalose pathway would affect the production of trehalose degradation, which are glucose 6-phosphate (G6P) and UDP-glucose (UDP-G). These building blocks are essential for other metabolic pathways, e.g., glycolysis pathway, glycogen synthesis

pathway, which would lead to impaired ATP generation and imbalance of NADH/NAD⁺ ratio. ATP generation and NADH/NAD⁺ levels are important for the fungal growth and fungal pathogenesis (108, 120, 121). Therefore, ATP and NADH/NAD⁺ levels are necessary to be further investigated to observe other effects from trehalase enzyme inhibition. Nonetheless, we observed that at 24 hours, the conidial germination in the presence of validamycin A caught up with the control. This result suggests that *A. flavus* may use alternative pathways, e.g., mannitol pathway (122, 123), to assist the germination and cope with increased trehalose levels while decreasing building blocks, G6P and UDP-G. From this data, it also suggests that validamycin A may have a fungistatic effect on *A. flavus*.

In addition, we further observed that validamycin A had a combinative effect with amphotericin B. *A. flavus* ATCC204304, which is a standard strain for the antifungal susceptibility test, showed an additive effect of validamycin A and amphotericin B. For clinical isolates with high MICs of amphotericin B, more than 4 $\mu\text{g/mL}$, in the CLSI reference, it did not indicate the cutoff value of MIC for the resistance of amphotericin B in *A. flavus*, but Barchiesi F, et al. suggested that an *A. flavus* clinical isolate with MIC of amphotericin B $\geq 2 \mu\text{g/mL}$ should be considered as a resistant strain (111, 124). Interestingly, in these *A. flavus* clinical isolates, we

observed that there were synergistic effects between validamycin A and amphotericin B. Previously, in *A. fumigatus*, disruption of trehalose enzymes, TpsA/B and OrlA, or a regulatory-like subunit, TslA, affects the cell wall structure and components, glucan and chitin (76, 77, 107). We hypothesize that disruption of trehalase enzymes may affect the cell wall structure and components leading to increasing effects of antifungal agents, i.e. amphotericin B. However, changes on *A. flavus* cell wall in the presence of validamycin A or in *A. flavus* mutants without trehalase enzymes need further investigation. Furthermore, we also hypothesize that different combinative effects of these agents between strains may be from the difference of cell wall structure and components in each clinical isolate with high MICs of amphotericin B. A previous study showed that amphotericin B resistant strains of *A. flavus* had similar sterol content while on the cell wall (1,3)- β -D-glucan content was higher in resistant strains (68). Therefore, the cell wall structure and components of these isolates need to be further studied. Moreover, more clinical isolates and animal models are also necessary to study this synergistic effect between validamycin A and amphotericin B.

Additionally, for the cytotoxic effect of validamycin A, we observed that validamycin A had no cytotoxic effect with human bronchial epithelial cells (Figure 10). However, we only utilized one human cell line, which may not represent the

overall cytotoxic effect on humans. However, acute toxicity in rodents, Lethal dose at 50 percentage (LD50), was found in a very high dose manner (<https://pubchem.ncbi.nlm.nih.gov/compound/Validamycin-A>). More animal studies are warranted to observe the toxicity of validamycin A in vivo.

In conclusion, validamycin A, a trehalase inhibitor, was able to inhibit the growth of *A. flavus*. One of the mechanisms behind the effect of validamycin A was to delay the germination of *A. flavus* spores. In addition, validamycin A also possessed synergistic effects with amphotericin B, a fungicidal antifungal agent, in amphotericin B-resistant clinical isolates. The cytotoxicity of validamycin A to human bronchial epithelial cells was not observed. This validamycin A could be one of the potential combinatorial agents for future treatment of amphotericin B-resistant *A. flavus* clinical isolates (Figure 11).

Figure 11. Model of the effects of validamycin A on the growth of *Aspergillus flavus* and the combinative effects of validamycin A and amphotericin B

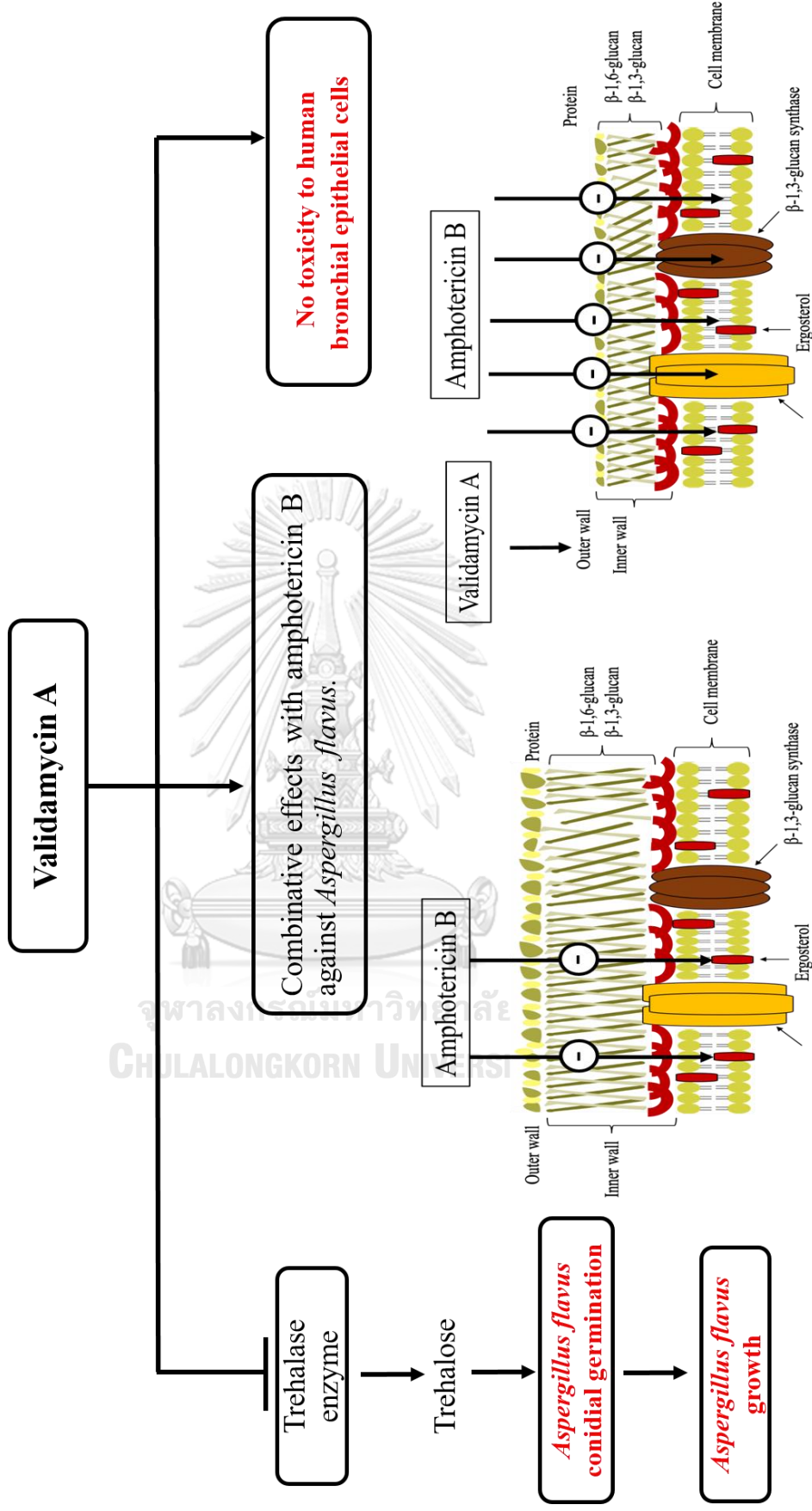

REFERENCES



จุฬาลงกรณ์มหาวิทยาลัย
CHULALONGKORN UNIVERSITY



จุฬาลงกรณ์มหาวิทยาลัย
CHULALONGKORN UNIVERSITY

VITA

NAME Napasawan Plabutong

DATE OF BIRTH 6 March 1995

PLACE OF BIRTH Kanchanaburi

INSTITUTIONS ATTENDED Bachelor's Degree: Faculty of Applied Science Department of Biotechnology, King Mongkut's University of Technology North Bangkok

HOME ADDRESS 14 Moo.2 Nongkum Bo Phloi District Kanchanaburi 71160



1. Jung JY, Yoon D, Choi Y, Kim HA, Suh CH. Associated clinical factors for serious infections in patients with systemic lupus erythematosus. *Sci Rep*. 2019;9(1):9704.
2. Kume H, Yamazaki T, Togano T, Abe M, Tanuma H, Kawana S, et al. Epidemiology of visceral mycoses in autopsy cases in Japan: comparison of the data from 1989, 1993, 1997, 2001, 2005 and 2007 in Annual of Pathological Autopsy Cases in Japan. *Med Mycol J*. 2011;52(2):117-27.
3. Chakrabarti A, Chatterjee SS, Shivaprakash MR. Overview of opportunistic fungal infections in India. *Nihon Ishinkin Gakkai Zasshi*. 2008;49(3):165-72.
4. Slavin MA, Australian Mycology Interest G. The epidemiology of candidaemia and mould infections in Australia. *J Antimicrob Chemother*. 2002;49 Suppl 1:3-6.
5. Chayakulkeeree M, Denning DW. Serious fungal infections in Thailand. *Eur J Clin Microbiol Infect Dis*. 2017;36(6):931-5.
6. Imwidthaya P. Systemic fungal infections in Thailand. *J Med Vet Mycol*. 1994;32(5):395-9.
7. Mahaisavariya P, Chaiprasert A, Sivayathorn A, Khemngern S. Deep fungal and higher bacterial skin infections in Thailand: clinical manifestations and treatment regimens. *Int J Dermatol*. 1999;38(4):279-84.
8. Kiertiburanakul S, Thibbadee C, Santanirand P. Invasive aspergillosis in a tertiary-care hospital in Thailand. *J Med Assoc Thai*. 2007;90(5):895-902.
9. Thammahong A, Thayidathara P, Suksawat K, Chindamporn A. Invasive Aspergillus Infections in a Thai Tertiary-Care Hospital during 2006-2011. *Adv Microbiol*. 2015;5(5):298-306.
10. van Burik JA, Colven R, Spach DH. Cutaneous aspergillosis. *J Clin Microbiol*. 1998;36(11):3115-21.
11. Brown GD, Denning DW, Gow NA, Levitz SM, Netea MG, White TC. Hidden killers: human fungal infections. *Sci Transl Med*. 2012;4(165):165rv13.
12. Hsu IC, Metcalf RA, Sun T, Welsh JA, Wang NJ, Harris CC. Mutational hotspot in the p53 gene in human hepatocellular carcinomas. *Nature*. 1991;350(6317):427-8.

13. Hedayati MT, Pasqualotto AC, Warn PA, Bowyer P, Denning DW. *Aspergillus flavus*: human pathogen, allergen and mycotoxin producer. *Microbiology*. 2007;153(Pt 6):1677-92.
14. Pasqualotto AC. Differences in pathogenicity and clinical syndromes due to *Aspergillus fumigatus* and *Aspergillus flavus*. *Med Mycol*. 2009;47 Suppl 1:S261-70.
15. Krishnan S, Manavathu EK, Chandrasekar PH. *Aspergillus flavus*: an emerging non-*fumigatus* *Aspergillus* species of significance. *Mycoses*. 2009;52(3):206-22.
16. Patterson TF, Thompson GR, 3rd, Denning DW, Fishman JA, Hadley S, Herbrecht R, et al. Practice Guidelines for the Diagnosis and Management of Aspergillosis: 2016 Update by the Infectious Diseases Society of America. *Clin Infect Dis*. 2016;63(4):e1-e60.
17. Fanos V, Cataldi L. Amphotericin B-induced nephrotoxicity: a review. *J Chemother*. 2000;12(6):463-70.
18. Perltroth J, Choi B, Spellberg B. Nosocomial fungal infections: epidemiology, diagnosis, and treatment. *Med Mycol*. 2007;45(4):321-46.
19. Gauwerky K, Borelli C, Korting HC. Targeting virulence: a new paradigm for antifungals. *Drug Discov Today*. 2009;14(3-4):214-22.
20. Perfect JR. Fungal virulence genes as targets for antifungal chemotherapy. *Antimicrob Agents Chemother*. 1996;40(7):1577-83.
21. Hu W, Feng Z, Eveleigh J, Iyer G, Pan J, Amin S, et al. The major lipid peroxidation product, trans-4-hydroxy-2-nonenal, preferentially forms DNA adducts at codon 249 of human p53 gene, a unique mutational hotspot in hepatocellular carcinoma. *Carcinogenesis*. 2002;23(11):1781-9.
22. Amaike S, Keller NP. *Aspergillus flavus*. *Annu Rev Phytopathol*. 2011;49:107-33.
23. Sommer NF, Buchanan JR, Fortlage RJ. Aflatoxin and sterigmatocystin contamination of pistachio nuts in orchards. *Applied and environmental microbiology*. 1976;32(1):64-7.
24. Jain R, Singhal SK, Singla N, Punia RS, Chander J. Mycological Profile and Antifungal Susceptibility of Fungal Isolates from Clinically Suspected Cases of Fungal Rhinosinusitis in a Tertiary Care Hospital in North India. *Mycopathologia*. 2015;180(1-2):51-9.
25. Singh AK, Gupta P, Verma N, Khare V, Ahamad A, Verma V, et al. Fungal Rhinosinusitis: Microbiological and Histopathological Perspective. *J Clin Diagn Res*. 2017;11(7):DC10-DC2.

26. Prateek S, Banerjee G, Gupta P, Singh M, Goel MM, Verma V. Fungal rhinosinusitis: a prospective study in a University hospital of Uttar Pradesh. *Indian J Med Microbiol.* 2013;31(3):266-9.
27. Slavin MA, Chakrabarti A. Opportunistic fungal infections in the Asia-Pacific region. *Med Mycol.* 2012;50(1):18-25.
28. Tilak R, Singh A, Maurya OP, Chandra A, Tilak V, Gulati AK. Mycotic keratitis in India: a five-year retrospective study. *J Infect Dev Ctries.* 2010;4(3):171-4.
29. Surya Prakash Rao G, Mann SB, Talwar P, Arora MM. Primary mycotic infection of paranasal sinuses. *Mycopathologia.* 1984;84(2-3):73-6.
30. Thammahong A, Thayidathara P, Suksawat K, Chindamporn A. Invasive aspergillosis infections in a Thai tertiary-care hospital during 2006-2011. *Advances in Microbiology.* 2015;5(5):298-306.
31. Dagenais TR, Keller NP. Pathogenesis of *Aspergillus fumigatus* in Invasive Aspergillosis. *Clin Microbiol Rev.* 2009;22(3):447-65.
32. Ramesh MV, Sirakova TD, Kolattukudy PE. Cloning and characterization of the cDNAs and genes (*mep20*) encoding homologous metalloproteinases from *Aspergillus flavus* and *A. fumigatus*. *Gene.* 1995;165(1):121-5.
33. Zhu WS, Wojdyla K, Donlon K, Thomas PA, Eberle HI. Extracellular proteases of *Aspergillus flavus*. Fungal keratitis, proteases, and pathogenesis. *Diagnostic microbiology and infectious disease.* 1990;13(6):491-7.
34. Monod M, Capoccia S, Lechenne B, Zaugg C, Holdom M, Jousson O. Secreted proteases from pathogenic fungi. *Int J Med Microbiol.* 2002;292(5-6):405-19.
35. Pavlukova EB, Belozersky MA, Dunaevsky YE. Extracellular proteolytic enzymes of filamentous fungi. *Biochemistry (Mosc).* 1998;63(8):899-928.
36. Mori T, Matsumura M, Yamada K, Irie S, Oshimi K, Suda K, et al. Systemic aspergillosis caused by an aflatoxin-producing strain of *Aspergillus flavus*. *Med Mycol.* 1998;36(2):107-12.
37. Cadena J, Thompson GR, 3rd, Patterson TF. Invasive Aspergillosis: Current Strategies for Diagnosis and Management. *Infect Dis Clin North Am.* 2016;30(1):125-42.

38. Maschmeyer G, Haas A, Cornely OA. Invasive aspergillosis: epidemiology, diagnosis and management in immunocompromised patients. *Drugs*. 2007;67(11):1567-601.
39. Sherif R, Segal BH. Pulmonary aspergillosis: clinical presentation, diagnostic tests, management and complications. *Curr Opin Pulm Med*. 2010;16(3):242-50.
40. Kosmidis C, Denning DW. The clinical spectrum of pulmonary aspergillosis. *Thorax*. 2015;70(3):270-7.
41. De Pauw B, Walsh TJ, Donnelly JP, Stevens DA, Edwards JE, Calandra T, et al. Revised definitions of invasive fungal disease from the European Organization for Research and Treatment of Cancer/Invasive Fungal Infections Cooperative Group and the National Institute of Allergy and Infectious Diseases Mycoses Study Group (EORTC/MSG) Consensus Group. *Clin Infect Dis*. 2008;46(12):1813-21.
42. Donnelly JP, Chen SC, Kauffman CA, Steinbach WJ, Baddley JW, Verweij PE, et al. Revision and Update of the Consensus Definitions of Invasive Fungal Disease From the European Organization for Research and Treatment of Cancer and the Mycoses Study Group Education and Research Consortium. *Clin Infect Dis*. 2019.
43. Ullmann AJ, Aguado JM, Arikian-Akdagli S, Denning DW, Groll AH, Lagrou K, et al. Diagnosis and management of *Aspergillus* diseases: executive summary of the 2017 ESCMID-ECMM-ERS guideline. *Clin Microbiol Infect*. 2018;24 Suppl 1:e1-e38.
44. Guinea J, Bouza E. Current challenges in the microbiological diagnosis of invasive aspergillosis. *Mycopathologia*. 2014;178(5-6):403-16.
45. Stewart ER, Thompson GR. Treatment of Primary Pulmonary Aspergillosis: An Assessment of the Evidence. *J Fungi (Basel)*. 2016;2(3).
46. Martin-Pena A, Aguilar-Guisado M, Espigado I, Cisneros JM. Antifungal combination therapy for invasive aspergillosis. *Clin Infect Dis*. 2014;59(10):1437-45.
47. Medeiros BC. Management of invasive Aspergillosis in acute myelogenous leukemia. *Clin Adv Hematol Oncol*. 2016;14(7):502-4.
48. George R, Thompson TFP. *Aspergillus Species* John E. Bennett RD, Martin J. Blaser, editor. Philadelphia, United States: Elsevier - Health Sciences Division; 2020. 257 p.
49. Chakrabarti A, Chatterjee SS, Das A, Shivaprakash MR. Invasive aspergillosis in developing countries. *Med Mycol*. 2011;49 Suppl 1:S35-47.

50. Cornely OA, Maertens J, Bresnik M, Ebrahimi R, Ullmann AJ, Bouza E, et al. Liposomal amphotericin B as initial therapy for invasive mold infection: a randomized trial comparing a high-loading dose regimen with standard dosing (AmBiLoad trial). *Clin Infect Dis*. 2007;44(10):1289-97.
51. Kuse ER, Chetchotisakd P, da Cunha CA, Ruhnke M, Barrios C, Raghunadharao D, et al. Micafungin versus liposomal amphotericin B for candidaemia and invasive candidosis: a phase III randomised double-blind trial. *Lancet*. 2007;369(9572):1519-27.
52. Hamilton-Miller JM. Fungal sterols and the mode of action of the polyene antibiotics. *Adv Appl Microbiol*. 1974;17(0):109-34.
53. Torrado JJ, Espada R, Ballesteros MP, Torrado-Santiago S. Amphotericin B formulations and drug targeting. *J Pharm Sci*. 2008;97(7):2405-25.
54. Anderson TM, Clay MC, Cioffi AG, Diaz KA, Hisao GS, Tuttle MD, et al. Amphotericin forms an extramembranous and fungicidal sterol sponge. *Nat Chem Biol*. 2014;10(5):400-6.
55. Wong-Beringer A, Jacobs RA, Guglielmo BJ. Lipid formulations of amphotericin B: clinical efficacy and toxicities. *Clin Infect Dis*. 1998;27(3):603-18.
56. Sawaya BP, Weihprecht H, Campbell WR, Lorenz JN, Webb RC, Briggs JP, et al. Direct vasoconstriction as a possible cause for amphotericin B-induced nephrotoxicity in rats. *J Clin Invest*. 1991;87(6):2097-107.
57. Laniado-Laborin R, Cabrales-Vargas MN. Amphotericin B: side effects and toxicity. *Rev Iberoam Micol*. 2009;26(4):223-7.
58. Safdar A, Ma J, Saliba F, Dupont B, Wingard JR, Hachem RY, et al. Drug-induced nephrotoxicity caused by amphotericin B lipid complex and liposomal amphotericin B: a review and meta-analysis. *Medicine (Baltimore)*. 2010;89(4):236-44.
59. Pai V, Ganavalli A, Kikkeri NN. Antifungal Resistance in Dermatology. *Indian J Dermatol*. 2018;63(5):361-8.
60. Shishodia SK, Tiwari S, Shankar J. Resistance mechanism and proteins in *Aspergillus* species against antifungal agents. *Mycology*. 2019;10(3):151-65.
61. Kanafani ZA, Perfect JR. Antimicrobial resistance: resistance to antifungal agents: mechanisms and clinical impact. *Clin Infect Dis*. 2008;46(1):120-8.

62. Beardsley J, Halliday CL, Chen SC, Sorrell TC. Responding to the emergence of antifungal drug resistance: perspectives from the bench and the bedside. *Future Microbiol.* 2018;13:1175-91.
63. Vahedi Shahandashti R, Lass-Flörl C. Antifungal resistance in *Aspergillus terreus*: A current scenario. *Fungal Genet Biol.* 2019;131:103247.
64. Van Der Linden JW, Warris A, Verweij PE. *Aspergillus* species intrinsically resistant to antifungal agents. *Med Mycol.* 2011;49 Suppl 1:S82-9.
65. Gomez-Lopez A, Garcia-Effron G, Mellado E, Monzon A, Rodriguez-Tudela JL, Cuenca-Estrella M. In vitro activities of three licensed antifungal agents against spanish clinical isolates of *Aspergillus* spp. *Antimicrob Agents Chemother.* 2003;47(10):3085-8.
66. Koss T, Bagheri B, Zeana C, Romagnoli MF, Grossman ME. Amphotericin B-resistant *Aspergillus flavus* infection successfully treated with caspofungin, a novel antifungal agent. *J Am Acad Dermatol.* 2002;46(6):945-7.
67. Bowman JC, Abruzzo GK, Flattery AM, Gill CJ, Hickey EJ, Hsu MJ, et al. Efficacy of caspofungin against *Aspergillus flavus*, *Aspergillus terreus*, and *Aspergillus nidulans*. *Antimicrob Agents Chemother.* 2006;50(12):4202-5.
68. Seo K, Akiyoshi H, Ohnishi Y. Alteration of cell wall composition leads to amphotericin B resistance in *Aspergillus flavus*. *Microbiol Immunol.* 1999;43(11):1017-25.
69. Thammahong A, Puttikamonkul S, Perfect JR, Brennan RG, Cramer RA. Central Role of the Trehalose Biosynthesis Pathway in the Pathogenesis of Human Fungal Infections: Opportunities and Challenges for Therapeutic Development. *Microbiol Mol Biol Rev.* 2017;81(2).
70. Elbein AD, Pan YT, Pastuszak I, Carroll D. New insights on trehalose: a multifunctional molecule. *Glycobiology.* 2003;13(4):17r-27r.
71. Elbein AD. The metabolism of alpha,alpha-trehalose. *Adv Carbohydr Chem Biochem.* 1974;30:227-56.
72. Petzold EW, Himmelreich U, Mylonakis E, Rude T, Toffaletti D, Cox GM, et al. Characterization and regulation of the trehalose synthesis pathway and its importance in the pathogenicity of *Cryptococcus neoformans*. *Infect Immun.* 2006;74(10):5877-87.

73. Zaragoza O, de Virgilio C, Ponton J, Gancedo C. Disruption in *Candida albicans* of the TPS2 gene encoding trehalose-6-phosphate phosphatase affects cell integrity and decreases infectivity. *Microbiology*. 2002;148(Pt 5):1281-90.
74. Van Dijck P, De Rop L, Szlufcik K, Van Ael E, Thevelein JM. Disruption of the *Candida albicans* TPS2 gene encoding trehalose-6-phosphate phosphatase decreases infectivity without affecting hypha formation. *Infect Immun*. 2002;70(4):1772-82.
75. Zaragoza O, Blazquez MA, Gancedo C. Disruption of the *Candida albicans* TPS1 gene encoding trehalose-6-phosphate synthase impairs formation of hyphae and decreases infectivity. *J Bacteriol*. 1998;180(15):3809-15.
76. Al-Bader N, Vanier G, Liu H, Gravelat FN, Urb M, Hoareau CM, et al. Role of trehalose biosynthesis in *Aspergillus fumigatus* development, stress response, and virulence. *Infect Immun*. 2010;78(7):3007-18.
77. Puttikamonkul S, Willger SD, Grahl N, Perfect JR, Movahed N, Bothner B, et al. Trehalose 6-phosphate phosphatase is required for cell wall integrity and fungal virulence but not trehalose biosynthesis in the human fungal pathogen *Aspergillus fumigatus*. *Mol Microbiol*. 2010;77(4):891-911.
78. Perfect JR, Tenor JL, Miao Y, Brennan RG. Trehalose pathway as an antifungal target. *Virulence*. 2017;8(2):143-9.
79. Burek M, Waskiewicz S, Wandzik I, Kaminska K. Trehalose - properties, biosynthesis and applications. *Chemik*. 2015;69(8):473-6.
80. Avonce N, Mendoza-Vargas A, Morett E, Iturriaga G. Insights on the evolution of trehalose biosynthesis. *BMC Evol Biol*. 2006;6:109.
81. Higashiyama T. Novel functions and applications of trehalose. *Pure Appl Chem*. 2002;74(7):1263-9.
82. Streeter JG, Bhagwat A. Biosynthesis of trehalose from maltooligosaccharides in *Rhizobia*. *Can J Microbiol*. 1999;45(8):716-21.
83. Wannet WJ, Op den Camp HJ, Wisselink HW, van der Drift C, Van Griensven LJ, Vogels GD. Purification and characterization of trehalose phosphorylase from the commercial mushroom *Agaricus bisporus*. *Biochim Biophys Acta*. 1998;1425(1):177-88.

84. Schiraldi C, Di Lernia I, De Rosa M. Trehalose production: exploiting novel approaches. *Trends Biotechnol.* 2002;20(10):420-5.
85. Qu Q, Lee SJ, Boos W. TreT, a novel trehalose glycosyltransferring synthase of the hyperthermophilic archaeon *Thermococcus litoralis*. *J Biol Chem.* 2004;279(46):47890-7.
86. Thevelein JM. Regulation of trehalose mobilization in fungi. *Microbiol Rev.* 1984;48(1):42-59.
87. Beltran FF, Castillo R, Vicente-Soler J, Cansado J, Gacto M. Role for trehalase during germination of spores in the fission yeast *Schizosaccharomyces pombe*. *FEMS Microbiol Lett.* 2000;193(1):117-21.
88. Ngamskulrunroj P, Himmelreich U, Breger JA, Wilson C, Chayakulkeeree M, Krockenberger MB, et al. The Trehalose Synthesis Pathway Is an Integral Part of the Virulence Composite for *Cryptococcus gattii*. *Infection and Immunity.* 2009;77(10):4584-96.
89. De Virgilio C, Burckert N, Bell W, Jenö P, Boller T, Wiemken A. Disruption of TPS2, the gene encoding the 100-kDa subunit of the trehalose-6-phosphate synthase/phosphatase complex in *Saccharomyces cerevisiae*, causes accumulation of trehalose-6-phosphate and loss of trehalose-6-phosphate phosphatase activity. *Eur J Biochem.* 1993;212(2):315-23.
90. Hellweger FL, Fredrick ND, Berges JA. Age-correlated stress resistance improves fitness of yeast: support from agent-based simulations. *BMC Syst Biol.* 2014;8:18.
91. Bell W, Sun W, Hohmann S, Wera S, Reinders A, De Virgilio C, et al. Composition and functional analysis of the *Saccharomyces cerevisiae* trehalose synthase complex. *J Biol Chem.* 1998;273(50):33311-9.
92. Zhou Y, Keyhani NO, Zhang Y, Luo Z, Fan Y, Li Y, et al. Dissection of the contributions of cyclophilin genes to development and virulence in a fungal insect pathogen. *Environ Microbiol.* 2016;18(11):3812-26.
93. Kienle I, Burgert M, Holzer H. Assay of trehalose with acid trehalase purified from *Saccharomyces cerevisiae*. *Yeast (Chichester, England).* 1993;9(6):607-11.
94. Zahringer H, Burgert M, Holzer H, Nwaka S. Neutral trehalase Nth1p of *Saccharomyces cerevisiae* encoded by the NTH1 gene is a multiple stress responsive protein. *FEBS Lett.* 1997;412(3):615-20.

95. Nwaka S, Mechler B, Holzer H. Deletion of the ATH1 gene in *Saccharomyces cerevisiae* prevents growth on trehalose. *FEBS Lett.* 1996;386(2-3):235-8.
96. Pedreno Y, Maicas S, Arguelles JC, Sentandreu R, Valentin E. The ATC1 gene encodes a cell wall-linked acid trehalase required for growth on trehalose in *Candida albicans*. *J Biol Chem.* 2004;279(39):40852-60.
97. Jules M, Guillou V, Francois J, Parrou JL. Two distinct pathways for trehalose assimilation in the yeast *Saccharomyces cerevisiae*. *Applied and environmental microbiology.* 2004;70(5):2771-8.
98. Pedreno Y, Gonzalez-Parraga P, Martinez-Esparza M, Sentandreu R, Valentin E, Arguelles JC. Disruption of the *Candida albicans* ATC1 gene encoding a cell-linked acid trehalase decreases hypha formation and infectivity without affecting resistance to oxidative stress. *Microbiology.* 2007;153(Pt 5):1372-81.
99. Svanstrom A, Melin P. Intracellular trehalase activity is required for development, germination and heat-stress resistance of *Aspergillus niger* conidia. *Res Microbiol.* 2013;164(2):91-9.
100. Mahmud T, Lee S, Floss HG. The biosynthesis of acarbose and validamycin. *Chem Rec.* 2001;1(4):300-10.
101. Dong H, Mahmud T, Tornus I, Lee S, Floss HG. Biosynthesis of the validamycins: identification of intermediates in the biosynthesis of validamycin A by *Streptomyces hygroscopicus* var. *limoneus*. *J Am Chem Soc.* 2001;123(12):2733-42.
102. Mahmud T, Deng Z, Bai L, Xu H, Yang J. Methods of producing validamycin A analogs and uses thereof. *Google Patents*; 2012.
103. Robson GD, Kuhn PJ, Trinci AP. Effects of validamycin A on the morphology, growth and sporulation of *Rhizoctonia cerealis*, *Fusarium culmorum* and other fungi. *J Gen Microbiol.* 1988;134(12):3187-94.
104. Guirao-Abad JP, Sanchez-Fresneda R, Valentin E, Martinez-Esparza M, Arguelles JC. Analysis of validamycin as a potential antifungal compound against *Candida albicans*. *Int Microbiol.* 2013;16(4):217-25.
105. Hartley D, Kidd H. *The Agrochemicals Handbook*. 2nd ed ed. Lechworth, Herts, England: The Royal Society of Chemistry; 1987.

106. Randhawa HS, Chowdhary A, Preeti Sinha K, Kowshik T, Vijayan VK. Evaluation of peptone glucose fluconazole agar as a selective medium for rapid and enhanced isolation of *Aspergillus fumigatus* from the respiratory tract of bronchopulmonary aspergillosis patients colonized by *Candida albicans*. *Med Mycol*. 2006;44(4):343-8.
107. Thammahong A, Caffrey-Card AK, Dhingra S, Obar JJ, Cramer RA. *Aspergillus fumigatus* Trehalose-Regulatory Subunit Homolog Moonlights To Mediate Cell Wall Homeostasis through Modulation of Chitin Synthase Activity. *MBio*. 2017;8(2).
108. Grahl N, Dinamarco TM, Willger SD, Goldman GH, Cramer RA. *Aspergillus fumigatus* mitochondrial electron transport chain mediates oxidative stress homeostasis, hypoxia responses and fungal pathogenesis. *Mol Microbiol*. 2012;84(2):383-99.
109. van de Sande WW, Tavakol M, van Vianen W, Bakker-Woudenberg IA. The effects of antifungal agents to conidial and hyphal forms of *Aspergillus fumigatus*. *Med Mycol*. 2010;48(1):48-55.
110. Shepardson KM, Ngo LY, Amanianda V, Latge JP, Barker BM, Blosser SJ, et al. Hypoxia enhances innate immune activation to *Aspergillus fumigatus* through cell wall modulation. *Microbes Infect*. 2013;15(4):259-69.
111. Clinical and Laboratory Standards Institute. Reference Method for Broth Dilution Antifungal Susceptibility Testing of Filamentous Fungi; Approved Standard. Third ed. CLSI document M38-A3: Pennsylvania, USA; 2017.
112. Meletiadiis J, Pournaras S, Roilides E, Walsh TJ. Defining fractional inhibitory concentration index cutoffs for additive interactions based on self-drug additive combinations, Monte Carlo simulation analysis, and in vitro-in vivo correlation data for antifungal drug combinations against *Aspergillus fumigatus*. *Antimicrob Agents Chemother*. 2010;54(2):602-9.
113. Perdoni F, Signorelli P, Cirasola D, Caretti A, Galimberti V, Biggiogera M, et al. Antifungal activity of Myriocin on clinically relevant *Aspergillus fumigatus* strains producing biofilm. *BMC Microbiol*. 2015;15:248.
114. Pfaller MA, Sheehan DJ, Rex JH. Determination of fungicidal activities against yeasts and molds: lessons learned from bactericidal testing and the need for standardization. *Clin Microbiol Rev*. 2004;17(2):268-80.

115. Balouiri M, Sadiki M, Ibnsouda SK. Methods for in vitro evaluating antimicrobial activity: A review. *J Pharm Anal.* 2016;6(2):71-9.
116. Park YH, Kim D, Dai J, Zhang Z. Human bronchial epithelial BEAS-2B cells, an appropriate in vitro model to study heavy metals induced carcinogenesis. *Toxicol Appl Pharmacol.* 2015;287(3):240-5.
117. Zhou TC, Kim BG, Zhong JJ. Enhanced production of validamycin A in *Streptomyces hygroscopicus* 5008 by engineering validamycin biosynthetic gene cluster. *Appl Microbiol Biotechnol.* 2014;98(18):7911-22.
118. Wu Q, Zhang L, Xia H, Yu C, Dou K, Li Y, et al. Omics for understanding synergistic action of validamycin A and *Trichoderma asperellum* GDFS1009 against maize sheath blight pathogen. *Sci Rep.* 2017;7:40140.
119. Thammahong A, Dhingra S, Bultman KM, Kerkaert JD, Cramer RA. An Ssd1 Homolog Impacts Trehalose and Chitin Biosynthesis and Contributes to Virulence in *Aspergillus fumigatus*. *mSphere.* 2019;4(3).
120. Joseph-Horne T, Hollomon DW, Wood PM. Fungal respiration: a fusion of standard and alternative components. *Biochim Biophys Acta.* 2001;1504(2-3):179-95.
121. Willger SD, Grahl N, Cramer RA, Jr. *Aspergillus fumigatus* metabolism: clues to mechanisms of in vivo fungal growth and virulence. *Med Mycol.* 2009;47 Suppl 1:S72-9.
122. Ruijter GJ, Bax M, Patel H, Flitter SJ, van de Vondervoort PJ, de Vries RP, et al. Mannitol is required for stress tolerance in *Aspergillus niger* conidiospores. *Eukaryot Cell.* 2003;2(4):690-8.
123. van Leeuwen MR, Krijgsheld P, Bleichrodt R, Menke H, Stam H, Stark J, et al. Germination of conidia of *Aspergillus niger* is accompanied by major changes in RNA profiles. *Stud Mycol.* 2013;74(1):59-70.
124. Barchiesi F, Spreghini E, Sanguinetti M, Giannini D, Manso E, Castelli P, et al. Effects of amphotericin B on *Aspergillus flavus* clinical isolates with variable susceptibilities to the polyene in an experimental model of systemic aspergillosis. *J Antimicrob Chemother.* 2013;68(11):2587-91.



จุฬาลงกรณ์มหาวิทยาลัย
CHULALONGKORN UNIVERSITY

APPENDIX I

***Aspergillus flavus* and *Aspergillus fumigatus* are able to utilize trehalose as a sole carbon source.**

Aspergillus flavus ATCC 204304 and *Aspergillus fumigatus* ATCC 204305 were cultured on Sabouraud Dextrose Agar (SDA) at 37°C for three days before harvesting using sterile distilled water. Then, 10³ spores were inoculated into each culture medium: glucose peptone agar, trehalose peptone agar, and peptone alone agar at 37°C for 2 and 5 days to measure the radial growth of these fungi. These experiments were performed in a biological triplicate manner

In this study, the results showed that *Aspergillus flavus* and *Aspergillus fumigatus* grew normally on trehalose peptone media. The growth of *Aspergillus flavus* on glucose peptone media was similar to trehalose peptone media (Figure 1). This preliminary data supports that *Aspergillus flavus* could utilize trehalose as a sole carbon source, which implies that *Aspergillus flavus* can degrade trehalose into glucose for the growth of the fungus using trehalase enzyme.

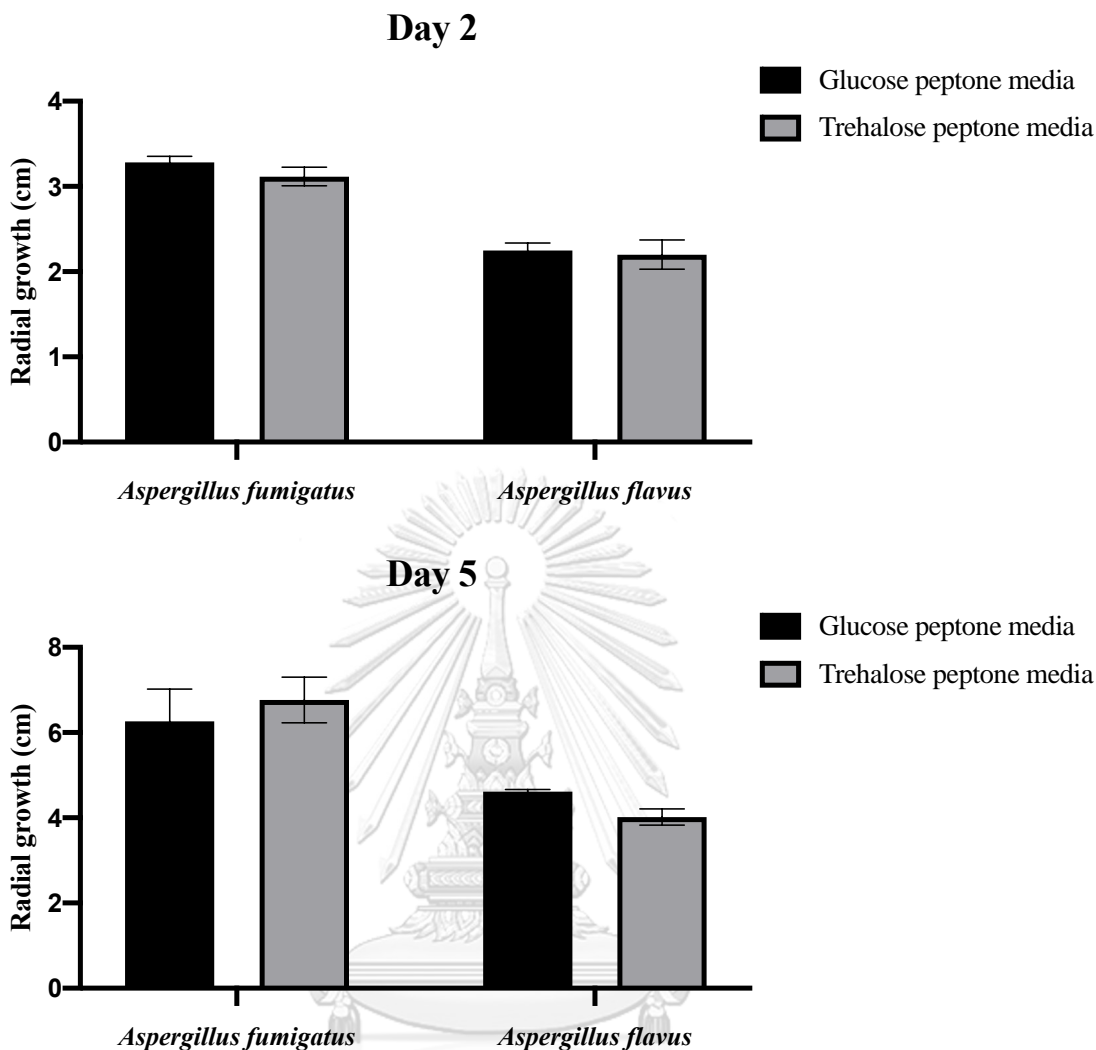

Figure 1. *Aspergillus fumigatus* and *Aspergillus flavus* grow normally on both glucose and trehalose peptone media on the second day and fifth day. *Aspergillus fumigatus* ATCC204305 and *Aspergillus flavus* ATCC204304 were cultured at 37°C on different media, glucose and trehalose peptone media. The radial growth of these fungi was measured on the second day. Unpaired *t*-test was used to compare the radial growth. These experiments were performed in a biological triplicate manner.

APPENDIX II

Validamycin A inhibits the growth of *Aspergillus flavus*.

10^3 spores of *Aspergillus flavus* ATCC 204304 strain were grown on glucose peptone media with or without validamycin A at concentration of 20 $\mu\text{g}/\text{mL}$ at 37 °C.

Radial growth was measured at 2 and 5 days (Figure 1)

The results show that validamycin A could inhibit the radial growth of *Aspergillus flavus*. The preliminary result showed that validamycin A inhibited the radial growth of *A. flavus* significantly at the second and fifth day (Figure 1).

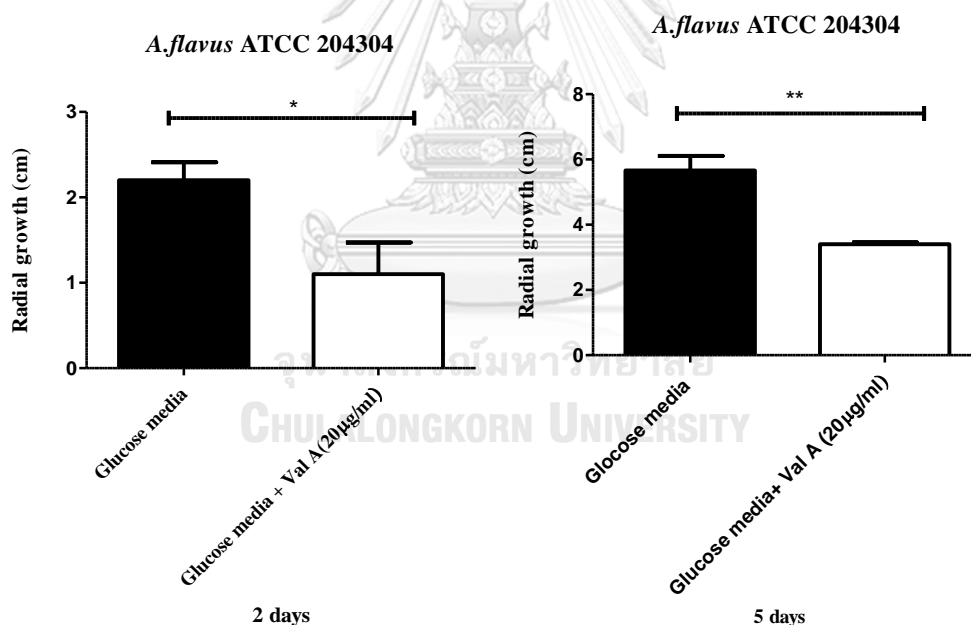

Figure 1. Validamycin inhibits the growth of *A. flavus*. *Aspergillus flavus* ATCC204304 was cultured at 37°C on glucose peptone media with or without 20

$\mu\text{g/mL}$ validamycin A. We measured the radial growth on the second and fifth day.

Unpaired t-test, three biological replicates, * p-value < 0.05; ** p-value < 0.01



APPENDIX III

1. Validamycin A has combinative effects against *Aspergillus flavus* ATCC204304 and *Aspergillus flavus* clinical isolates

The broth microdilution method (CLSI M38) was performed to observe the minimum inhibitory concentrations (MICs) of amphotericin B in *Aspergillus flavus* ATCC 204304 and clinical isolates (111). After that, the additive/synergistic effect of validamycin A and amphotericin B were studied using the checkerboard assays (112). To determine the additive and synergistic effect, the fractional inhibitory concentration index (FICI) was calculated for each antifungal drug in each combination using the following formula (112): $FIC_A (MIC_A/MIC_{A+B}) + FIC_B (MIC_B/MIC_{A+B}) = FICI$ and the following FICI results were determined as synergy: <0.5 ; additivity: $0.5-1$; indifference: $>1-4$; and antagonism: >4 .

Table 1 shows the results of checkerboard assays that were performed to observe the combination effect between validamycin A and amphotericin B. The fractional inhibitory concentration index (FICI) was calculated for validamycin A and amphotericin B in each combination of *Aspergillus flavus* clinical isolates

(Interpretation: A: additive; S: synergistic) and patient characteristics.

Table 1. Patient characteristics and FICI of *Aspergillus flavus* clinical isolates (Interpretation: A: additive; S: synergistic). DM2: Diabetes mellitus type 2; HT: Hypertension; CVA: Cerebrovascular accident; DLP: Dyslipidemia; Rt: Right; Lt: Left; HCV: Hepatitis C virus infection; AF: Atrial fibrillation; ALL: Acute lymphoblastic leukemia; COPD: Chronic obstructive pulmonary disease; ESRD: End stage renal disease; HBV: Hepatitis B virus infection; DIC: Disseminated intravascular coagulopathy ; CRBSI: Catheter-related bloodstream infection; VAP: Ventilator-associated pneumonia; CKD: Chronic kidney disease; N/A: Not available)

<i>A. flavus</i> strains	Specimen	Underlying diseases	Diagnosis	Treatment	Outcome	MICs of single agent alone (µg/mL)		MICs of combined agents (µg/mL)		FICI (µg/mL)	Interpretation
						Validamycin A	Amphotericin B	Validamycin A	Amphotericin B		
<i>A. flavus</i> (ECV, µg/ml)							4				
<i>A. flavus</i> ATCC204304						1	4	0.0125	2	0.5125	A
<i>A. flavus</i> ENT 2933.1	Invasive aspergillosis	DM2, HT, old CVA, DLP	Rt malignant otitis externa with skull base osteomyelitis/ chronic otitis Rt ear	N/A	Survive	>128	4	0.0039	1	0.25	S
<i>A. flavus</i> ENT 2932.1	Invasive aspergillosis	N/A	N/A	N/A	Survive	>128	2	0.0039	4	2	I
<i>A. flavus</i> Eye 0753	Invasive aspergillosis	DM2, DLP	Corneal ulcer Lt	Itraconazole, Natamycin, voriconazole	Survive	>128	2	0.125	1	0.5009	A

<i>A. flavus</i> strains	Specimen	Underlying diseases	Diagnosis	Treatment	Outcome	MICs of single agent alone (µg/mL)		MICs of combined agents(µg/mL)		FICI (µg/mL)	Interpretation
						Validamycin A	Amphotericin B	Validamycin A	Amphotericin B		
<i>A. flavus</i> ENT 9987	Invasive aspergillosis	HCV , paroxysmal AF	Acute-on-chronic liver failure; CRBSI with VAP with septic shock	Anidulafungin	Dead	>128	4	0.0039	4	1	I
<i>A. flavus</i> SP 0892	Invasive pulmonary aspergillosis	DM2	Autoimmune hepatitis; Invasive pulmonary aspergillosis	Liposomal amphotericin B	Dead	>128	2	0.0078	4	2	I
<i>A. flavus</i> Endo 7752	Invasive pulmonary aspergillosis	N/A	N/A	N/A	Survive	>128	4	0.0039	1	0.25	S
<i>A. flavus</i> Endo 0828	Invasive pulmonary aspergillosis	N/A	N/A	N/A	Survive	>128	2	0.0039	2	1	I

<i>A. flavus</i> strains	Specimen	Underlying diseases	Diagnosis	Treatment	Outcome	MICs of single agent alone (µg/mL)		MICs of combined agents (µg/mL)		FICI (µg/mL)	Interpretation
						Validamycin A	Amphotericin B	Validamycin A	Amphotericin B		
<i>A. flavus</i> Nasal 2544	Invasive aspergillosis	Dm2, HTN, CKD	<i>Klebsiella</i> pneumonia with septic shock	N/A	Survive	>128	4	0.0039	2	0.5	A
<i>A. flavus</i> NA 2993	Invasive aspergillosis	Pigmented basal cell carcinoma, nodular pattern; actinic keratosis, seborrheic dermatitis,	onychomycosis	N/A	Survive	>128	4	0.0039	4	1	I
<i>A. flavus</i> Tis 5976	Invasive aspergillosis	Gestational HTN	Chronic pulmonary aspergillosis with infected bronchiectasis	N/A	Survive	2	2	0.0039	2	1.0019	I

<i>A. flavus</i> strains	Specimen	Underlying diseases	Diagnosis	Treatment	Outcome	MICs of single agent alone (µg/mL)		MICs of combined agents (µg/mL)		FICI (µg/mL)	Interpretation
						Validamycin A	Amphotericin B	Validamycin A	Amphotericin B		
<i>A. flavus</i> 4312	Invasive aspergillosis	ALL: very high risk Pre B cell ALL	Recurrent epistaxis with invasive aspergillosis	Amphotericin B , voriconazole , posaconazole	Survive	>128	2	0.0039	1	0.5	A
<i>A. flavus</i> SP2690.2	Invasive aspergillosis	HT, COPD, ESRD, chronic HBV infection	Disseminated aspergillosis with septic shock and DIC	Amphotericin B	Dead	>128	2	0.0039	2	1	I
<i>A. flavus</i> ENT 1180	Invasive aspergillosis	N/A	Foreign body in Rt ear	N/A	Survive	>128	2	0.0039	4	2	I

2. Time-kill kinetics assay

Time kill assay was performed using the CLSI M26-A method. 10^3 spores of *A. flavus* with high amphotericin B (AMB) MIC strains were prepared, and liquid cultures in Sabouraud dextrose broth were performed at a concentration of $0.5 \times \text{MIC}$ from validamycin A and amphotericin B. Cultures were placed on the shaker at 200 rpm and incubated at 37°C . At each time point (4, 8, 12, 24, and 48 h), 100 μl of cultures were plated on SDA plates at 37°C for 24-48 h. The time-killing curves were determined by a count of colony-forming units (CFU/mL), at each time point (113-115).

The results showed that validamycin A had a synergistic effect with amphotericin B in *A. flavus* clinical isolates with high MIC of amphotericin B, and these synergistic effects were again confirmed by time-kill assays. The time-kill assay test found that when using a concentration of $0.5 \times \text{MIC}$ from validamycin A (0.125 $\mu\text{g}/\text{mL}$) and amphotericin B (2 $\mu\text{g}/\text{mL}$) to inhibit the growth of *Aspergillus flavus* clinical isolates. It could enhance the effect of inhibiting the growth of the *Aspergillus flavus* clinical isolates that was the best for 24 hours and the amount of colony-forming units was significantly different at 2 log decreases in CFU/mL (Figure 1A- C).

A)

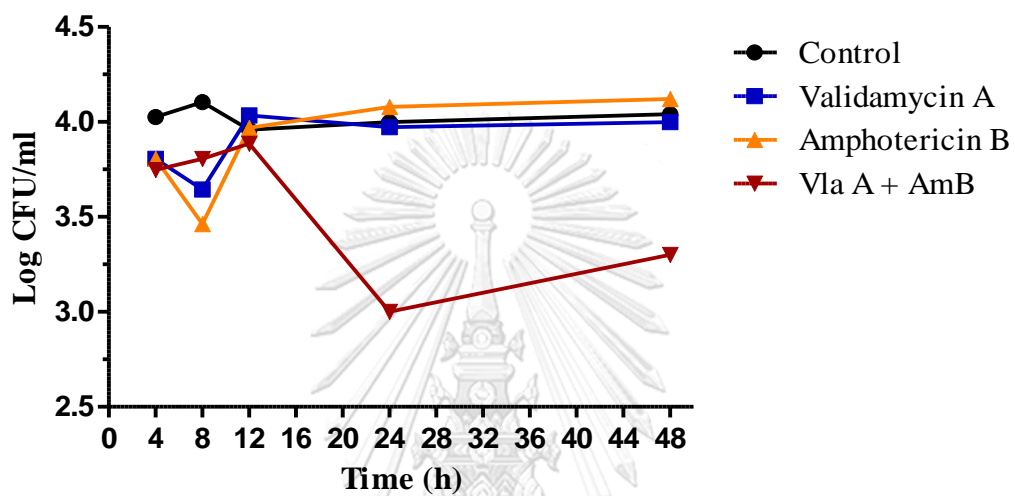
A.flavus SP 7183

B)

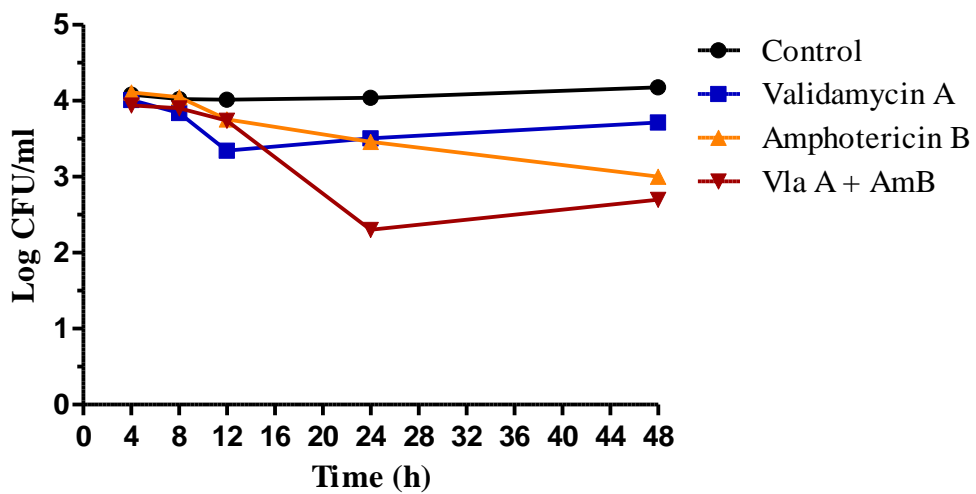
A.flavus SP 2252.3

C)

A.flavus sinus 2431

Figure 1. Validamycin has a synergistic effect with amphotericin B against *A. flavus* clinical isolates. Time kill assay was performed using the CLSI M26-A method. 10^3 spores of *A. flavus* with high amphotericin B (AMB) MIC strains were incubated at a concentration of $0.5 \times \text{MIC}$ of validamycin A ($0.125 \mu\text{g/mL}$) and amphotericin B ($2 \mu\text{g/mL}$). Each isolate was exposed to no drug (control, black circle), validamycin A at $0.125 \mu\text{g/mL}$ (blue square), amphotericin B at $2 \mu\text{g/mL}$ (yellow triangle), the combination of validamycin A at $0.125 \mu\text{g/mL}$ and amphotericin B at $2 \mu\text{g/mL}$ (red triangle). (A) SP7183, B) SP 2252.3, C) sinus 2431)

APPENDIX IV

Validamycin A has no cytotoxicity to human bronchial epithelial cell lines

BEAS-2B (Human bronchial epithelial cell line) (ATCC[®] CRL9609[™]) was cultured in bronchial epithelial cell growth media, and tissue culture flasks were coating with 0.01 mg/mL fibronectin, 0.03 mg/mL bovine collagen type I, and 0.01 mg/mL bovine serum albumin (BSA) dissolved in the culture medium. Cell cultures were incubated at 37°C in a humidified environment with 5% CO₂ (116).

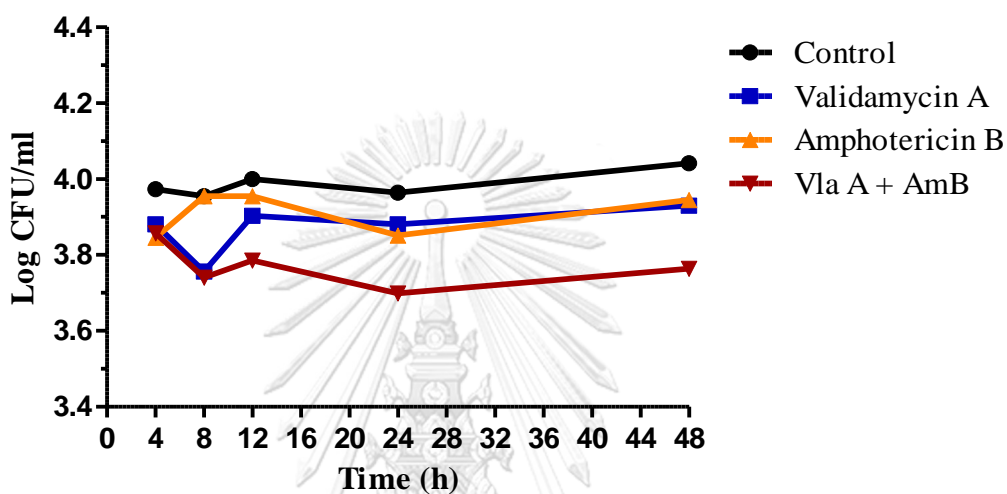
The cytotoxicity test was then performed to observe the toxicity of validamycin A to human epithelial cell lines using Lactate Dehydrogenase (LDH)-Cytotoxicity Colorimetric Assay Kit II (Biovision Inc, CA, USA). Briefly, 1 x 10⁴ BEAS-2B cells were incubated with 50 µl of DMEM in a pre-coating 96-well plate and then validamycin A will be added at the different concentrations, for each time point. LDH reaction mixture was added and incubated at 37°C for 30 minutes. Then ODs were measured at 450 nm using a spectrophotometer. Later, the percentage of the cytotoxicity was calculated using the following formula:

$$\text{Cytotoxicity (\%)} = \frac{(\text{test sample} - \text{low control}) \times 100}{(\text{high control} - \text{low control})}$$

The results showed that 0.5, 1 $\mu\text{g}/\text{mL}$ validamycin A and 0.5, 1 $\mu\text{g}/\text{mL}$ amphotericin B did not cause significant toxicity to human bronchial epithelial cells.

(Figure 1)

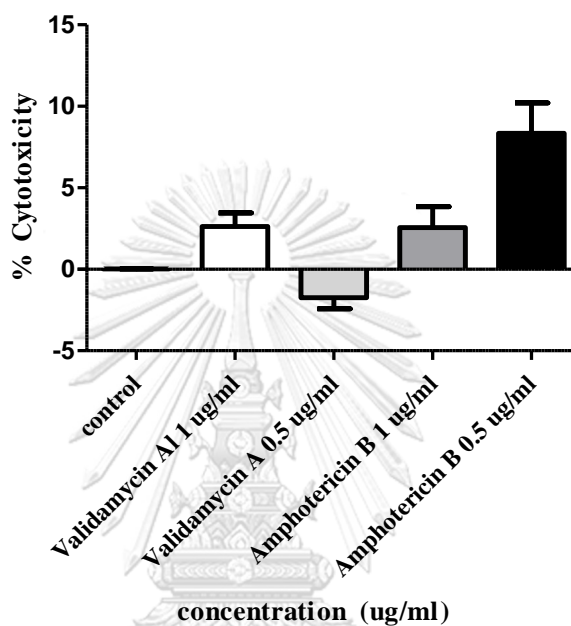

Figure 1. Validamycin A and amphotericin B have no cytotoxic effect on human bronchial epithelial cells. The cytotoxicity test was performed to observe the toxicity of validamycin A on BEAS-2B using lactate dehydrogenase (LDH)-Cytotoxicity Colorimetric Assay Kit II. Cell cultured were incubated at 37°C in a humidified environment containing 95% air-5% CO₂. After 24 hours, Using LDH reaction mixture was added for the volume of 25 μl , incubated at 37°C for 30 minutes. Then ODs were measured at 450 nm using a spectrophotometer. Data are presented as

means \pm SE from three biological replicates. NS: not significant (unpaired two-tailed

Student's t-test compared to the control).

