

CHAPTER III

EXPERIMENTAL

3.1 Materials

3.1.1 Banana Trunks

The *Musa sapientum* Linn banana trunks were obtained from local banana farm in Bangkok province, Thailand.

3.1.2 Natural Rubber Latex

Natural rubber latex was obtained from *Hevea brasiliensis* trees (Chantaburi province, Thailand).

3.1.3 Other Chemicals

Sodium hydroxide (NaOH) pellets (RANKEM, analytical grade), hydrogen peroxide (H₂O₂) (Fisher Scientific Co., Ltd, analytical grade), hydrochloric acid 37% (HCl) (Labscan analytical science, analytical grade), acetone (Chemical enterprise, commercial grade), 28.0-30.0 wt.% ammonium hydroxide (NH₃) solution (J.T. Baker, analytical grade), Zn(NO₃)₂, (Ajax Finechem Pty Ltd., technical grade) and toluene (Labscan analytical science, analytical grade) were used in this study.

3.1.4 Air gas for plasma treatment

Air zero (high purity) used in the plasma treatment was obtained from Thai Industrial Gas Co., Ltd. (Thailand).

3.2 Equipment

3.2.1 Water Contact angle measurement

Hydrophobicity of the surface will be evaluated by measuring the contact angle formed between water drops and the surface of the modified cellulose sheets and NR-coated cellulose sheets using contact angle measuring system G 10 (KRUSS). For this purpose, the drops of water will be mounted on three different areas of the surface with a microsyringe. The results will be mean values of three measurements on different parts of the sheet.

3.2.2 Ultraviolet–Visible Spectrophotometer (UV-Vis)

The UV-Vis Spectrophotometer (Tecan, Infinite M200) was used to examine the concentrations of bromine that reacted with double bond of coated natural rubber to determine the amount of coated natural rubber on cellulose sheet. The NR-coated cellulose sheets were soaked in solution of bromine in dichloromethane for 24 hr. The solution was analyzed at 240 nm with UV-VIS Spectrophotometer.

3.2.3 Wide Angle X-ray Diffraction (WAXD) Analysis

The crystalline structure of cellulose was characterized by an X-ray diffractometer (Bruker AXS, D8 advance) operated with the use of Cu K α as the X-ray source. The WAXD analysis was done in a continuous mode with a scan speed of 1° min⁻¹ covering the angle (2 θ) from 10° to 50°.

3.2.4 Fourier Transformed Infrared Spectroscopy (FTIR)

The untreated and DBD plasma treated banana cellulose-based sheets will be analyzed by a Thermo Nicolet Nexus 670 FTIR spectrometer. Samples will be recorded at a spectral resolution and wave number precision of 0.09 and 0.01 cm⁻¹, respectively. The fibers will be placed into the Smart Multi-Bounce HATR sample compartment of the spectrometer and continuously purged with dry air. For each spectrum, 64 scans will be acquired at a spectra resolution of 4 cm⁻¹.

3.2.5 Thermogravimetric Analyzer (TGA)

The thermal stability and the decomposition temperature of natural rubber, untreated and NR-coated cellulose sheets were analyzed by thermogravimetric analysis (TGA) (Dupont Instrument TGA 5.1, model 2950). The temperature range studied was 30-700 °C. TGA patterns were measured at a heating rate of 10 °C/min under a nitrogen gas atmosphere.

3.2.6 Scanning Electron Microscopy (SEM)

Scanning electron microscopy (SEM) will be performed on gold-coated samples, which will be obtained using a polaron sputter coater. A SEM operating condition typically at 10 kV will be employed for morphology study. Samples will be mounted onto the sample holder, sputter-coated with gold, and finally used for SEM analysis.

3.2.7 X-ray Photoelectron Spectroscopy (XPS)

The chemical composition of treated cellulose sheets and NR-coated cellulose sheets were also analyzed by Kratos Axis Ultra DLD with the active area 2 mm². The XPS spectra were excited by the Al K α X-ray source (1486.6 eV).

3.2.8 Brookfield Viscometer

The brookfield viscometer was used to examine the viscosity of natural rubber in toluene at different concentrations with NO. spindle 1 at 200 RPM.

3.2.9 Water absorbency time

Water absorbency time of the cellulose sheets was measured according to AATCC 79-2007 method. A water droplet of 37 μ l was placed on the sheet, which was held horizontally in a frame. The time for the water droplet to get fully absorbed by the sheet was recorded.

3.3 Methodology

3.3.1 Preparation of Cellulose Fiber

M. sapientum Linn banana trunks were cut into the length of 10 mm to 30 mm and dried for 48 hours in an oven at 60°C. The dried banana chips were then soaked in a 10 % (w/v) NaOH solution at 100°C for 1 hr. After thoroughly rinsed with distilled water, the banana chips were treated with a 15% (w/v) H₂O₂ solution at 95°C for 1.5 hr. The purified cellulose was disintegrated with a mixer and partially hydrolyzed at 70°C for 30 minutes in a 2 M hydrochloric acid solution. The resulting cellulose fibers were rinsed with distilled water until neutral and then disintegrated with a mixer until they were free of lumps when suspended in water.

3.3.2 Preparation of Cellulose-based Sheet

Cellulose fiber suspension was poured through a filter paper placed in a Buchner funnel. Water was drawn through the funnel into the flask below by vacuum. The fibers were trapped by the filter and formed sheet. The cellulose sheet was put in between two filter papers to absorb moisture and a weight was applied on the top to provide pressing force during drying at room temperature for 24 hr. The cellulose sheet was then dried in an oven at 60°C for 24 hr.

3.3.3 Preparation of Deproteinized Natural Rubber Solution

The commercial natural rubber latex was centrifuged at 13000 rpm for 5 min at room temperature to remove serum. Then, a 4 % (v/v) NH_4OH solution was added to the natural rubber latex. To remove the protein residues in the natural rubber latex, a 0.04 % (w/v) protease was added into the natural rubber latex suspension. The suspension was stirred for 24 hr at 50 °C. After that, the suspension was centrifuged at 13000 rpm for 5 min and the supernatant was discharged. The deproteinized natural rubber latex was resuspended and preserved in a 4 % (v/v) NH_4OH solution. The protein was removed from natural rubber latex in order to diminish the interference of protein on the interaction between natural rubber and cellulose induced by plasma treatment. The rubber latex was casted on the Teflon mold at room temperature before drying at 35°C to form a film. The rubber films were dissolved in toluene to prepare natural rubber solution.

3.3.4 Plasma Treatment and Sample Preparation

The banana cellulose-based sheets were cut into a square shape with the dimension of 3 cm × 3 cm before the DBD plasma treatment. The optimum operating condition for the DBD plasma treatment was operated at the voltage of 50 kV, the frequency of 325 Hz, and the electrode gap of 4 mm under air environment (Onsuratoom *et al.*, 2009). Figure 3.1 shows the experimental set up for DBD plasma treatment.

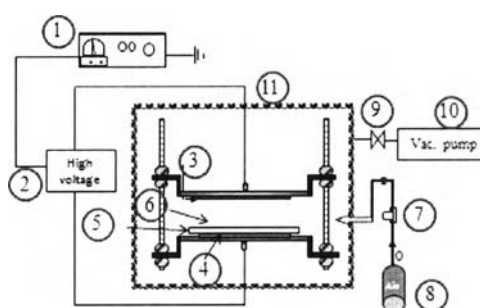

Figure 3.1 The DBD set up (1) power supply unit, (2) high voltage transformer, (3) upper electrode, (4) lower electrode, (5) dielectric glass, (6) cellulose sheet, (7) mass-flow controller, (8) air gas, (9) needle valve, (10) vacuum pump and (11) plasma chamber.

There are three ways of natural rubber-coated cellulose sheet preparation

A. After the plasma treatment, the cellulose-based sheet was immediately immersed in a natural rubber solution at different concentrations. The natural rubber-coated cellulose sheet was washed with an excess amount of toluene to remove the unreacted rubber and dried in air at 60°C overnight.

B. The cellulose-based sheet was immersed in a natural rubber solution and immediately treated with DBD plasma. After the plasma treatment, the cellulose-based sheet was immediately immersed in a natural rubber solution. Next, the natural rubber-coated cellulose sheet was washed with an excess amount of toluene to remove the unreacted rubber and dried in air at 60°C overnight.

C. After the plasma treatment, the cellulose-based sheet was dipped into an 0.5 M aqueous $\text{Zn}(\text{NO}_3)_2$ solution, followed by a drop wise addition of a 2.5 M NaOH solution. Next, the sample was washed with an excess amount of deionized water and dried in air at 60°C. ZnO-coated cellulose-based sheet was immersed in a natural rubber solution and immediately treated with DBD plasma. After the plasma treatment, the cellulose-based sheet was immediately immersed in a natural rubber solution. Next, the natural rubber-coated cellulose sheet was washed with an excess amount of toluene to remove the unreacted rubber and dried in air at 60°C overnight.

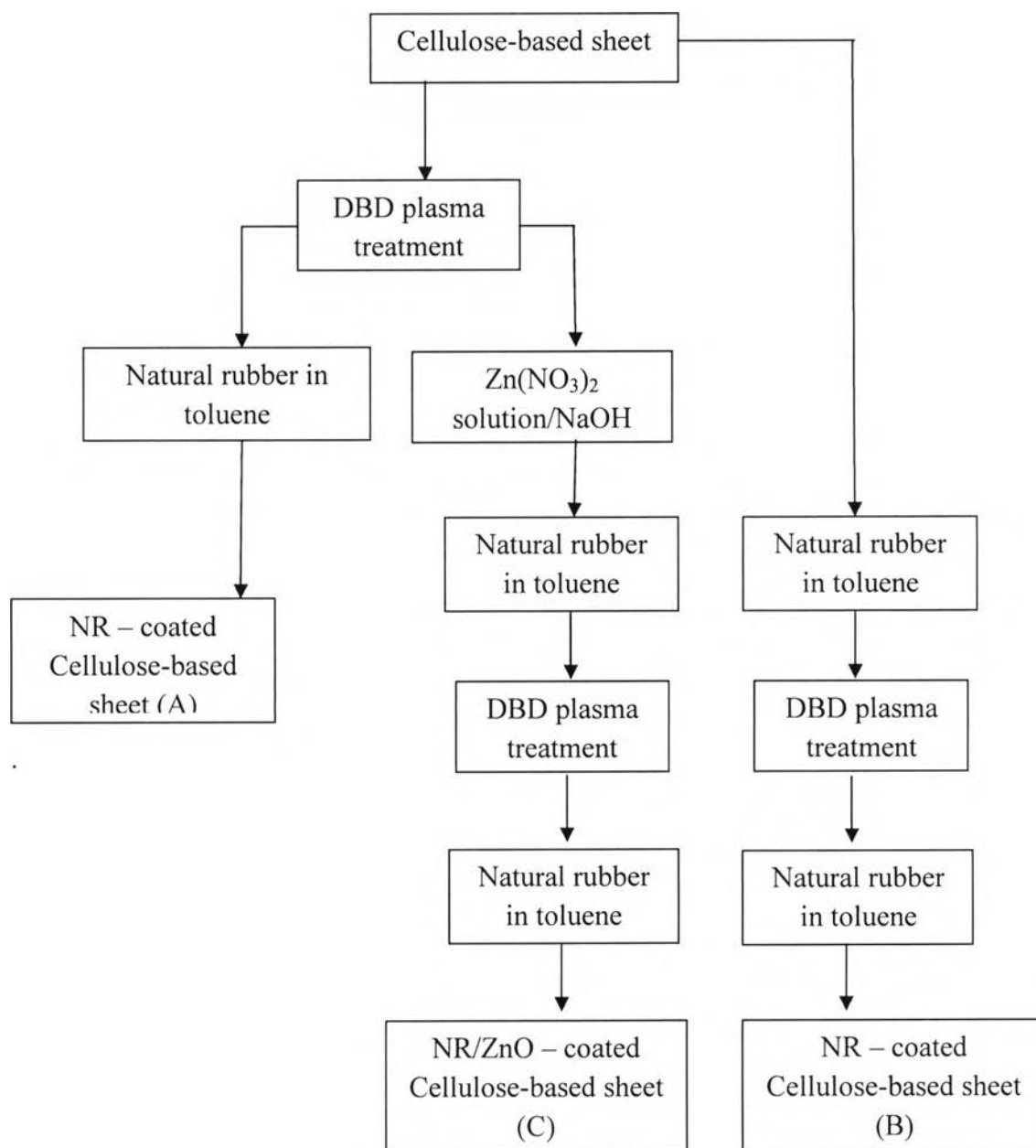

Figure 3.2 Flow chart of the entire experimental procedure.