



CHAPTER III METHODOLOGY

3.1 Materials

3.1.1 Gases

Gases used in this research work are:

- Pure nitrogen from Thai Industrial Gases Public Company Limited,
- High purity helium (99.99%) from Thai Industrial Gases Public Company Limited,
- Air Zero,
- 10.3% carbon monoxides in helium from Thai Industrial Gases Public Company Limited,
- High purity hydrogen (99.99%) from Thai Industrial Gases Public Company Limited,
- 5.46% oxygen balanced in helium from Thai Industrial Gases Public Company Limited, and
- 20% carbon dioxide from Thai Industrial Gases Public Company Limited.

3.1.2 Chemicals

Catalyst preparation required the following chemicals:

- Sodium carbonate anhydrous (Na_2CO_3) from MERCK,
- Hydrogen tetrachloroaurate (III) ($\text{HAuCl}_4 \cdot 3\text{H}_2\text{O}$) 99.9% purity from ACROS,
- Manganese (II) nitrate tetrahydrate ($\text{Mn}(\text{NO}_3)_2 \cdot 4\text{H}_2\text{O}$) 93.5% purity from MERCK, and
- Ferric (III) nitrate nonahydrate ($\text{Fe}(\text{NO}_3)_3 \cdot 9\text{H}_2\text{O}$) 99.9% purity from CARLD ERBA.

3.2 Experimental Setup

3.2.1 PROX Unit

The experimental system had 3 main parts as shown in Figure 3.1.

3.2.1.1 Gas Blending Section

The reactant gas was consisted of 1% CO, 1% O₂, and 40% H₂ balanced in He. Firstly, each stream was passed through a micro filter in order to remove particles before it entered the mass flow controllers; in order to achieve the desired concentration and then checked valve to prevent reverse flow. After that, all of streams were mixed in a mixer before going into the reactor with a total flow rate of 50 ml/min (SV=30000 mlg⁻¹h⁻¹) under atmospheric pressure.

3.2.1.2 Catalytic Reactor

The preferential oxidation (PROX) of CO was carried out in a pyrex glass U-tube micro-reactor with an inside diameter of 6 mm at atmospheric pressure. The catalyst was packed between glass wool plugs in the middle of the reactor. The temperature of the catalyst bed was monitored and controlled by PID temperature controller equipped with a chromel-alumel thermocouple (Type K).

3.2.1.3 Analytical Instrumentation

The effluent gas from the reactor was passed through water trapper before being qualitatively and quantitatively analyzed by auto-sampling into on-line gas chromatograph equipped with a packed carbosphere column, 80/100 mesh, and 10 ft x 1/8 inch and a thermal conductivity detector (TCD).

Figure 3.1 Schematic flow of PROX process.

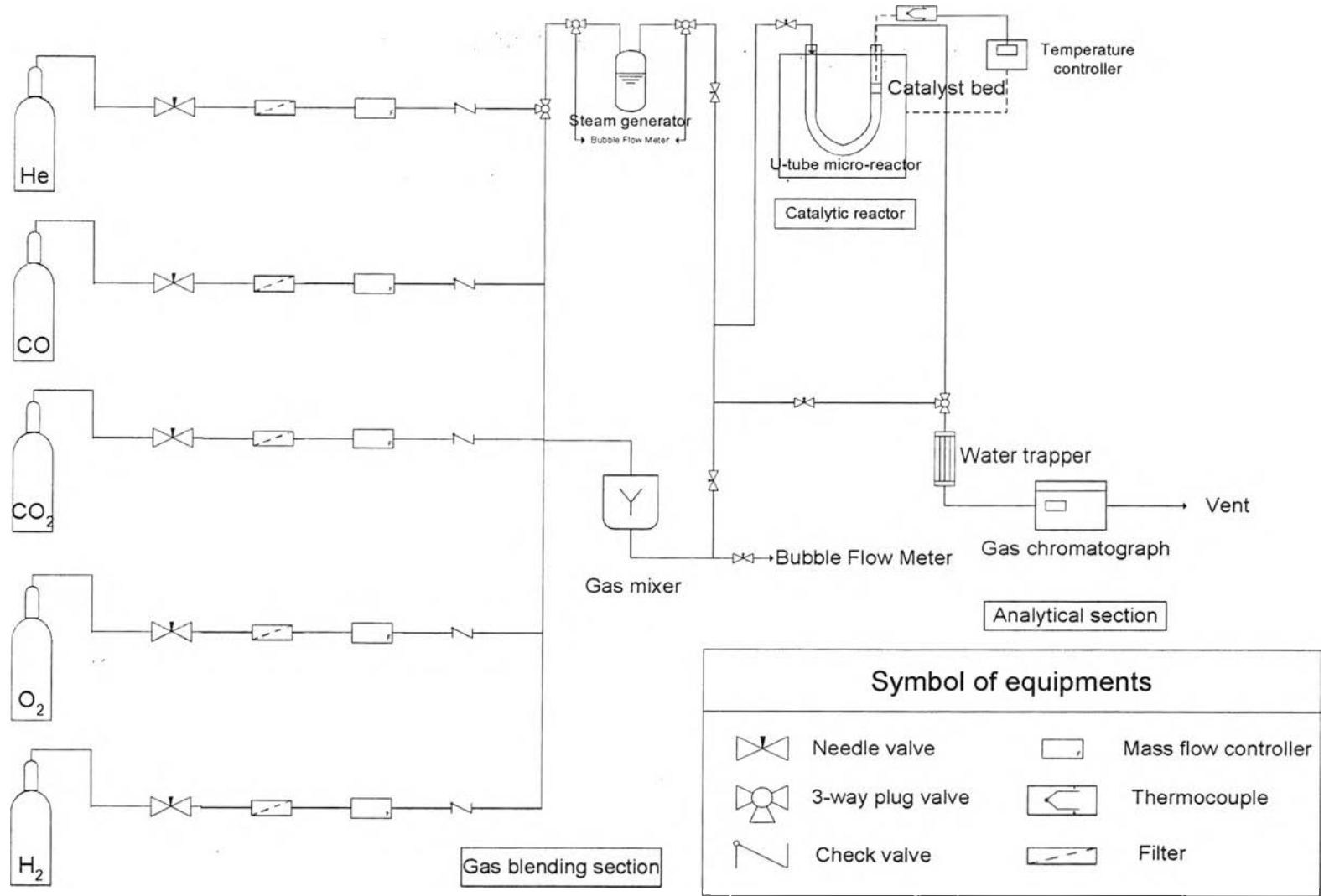

3.2.2 Fuel Processing System

The fuel processing system, consisting of four major units in series i.e. evaporators, methanol steam reformer reactor, high and low temperature water gas shift reactors, and preferential CO oxidation reactors, was constructed (Figure 3.2) to observe the catalytic activities in the real reformat. The methanol steam reformer is used to generate hydrogen stream. A methanol-water mixture was used as fuel in a reformer over a shifmax 240, commercial catalyst, to produce H₂, CO₂ and CO. The products coming out from the methanol steam reformer was passed through the high and low temperature water gas shift reactors. Finally, the H₂-rich gas was introduced to the PROX unit to eliminate trace amounts of CO in the H₂-rich stream to an acceptable level (<10 ppm), by the oxidation over a synthesized catalyst.

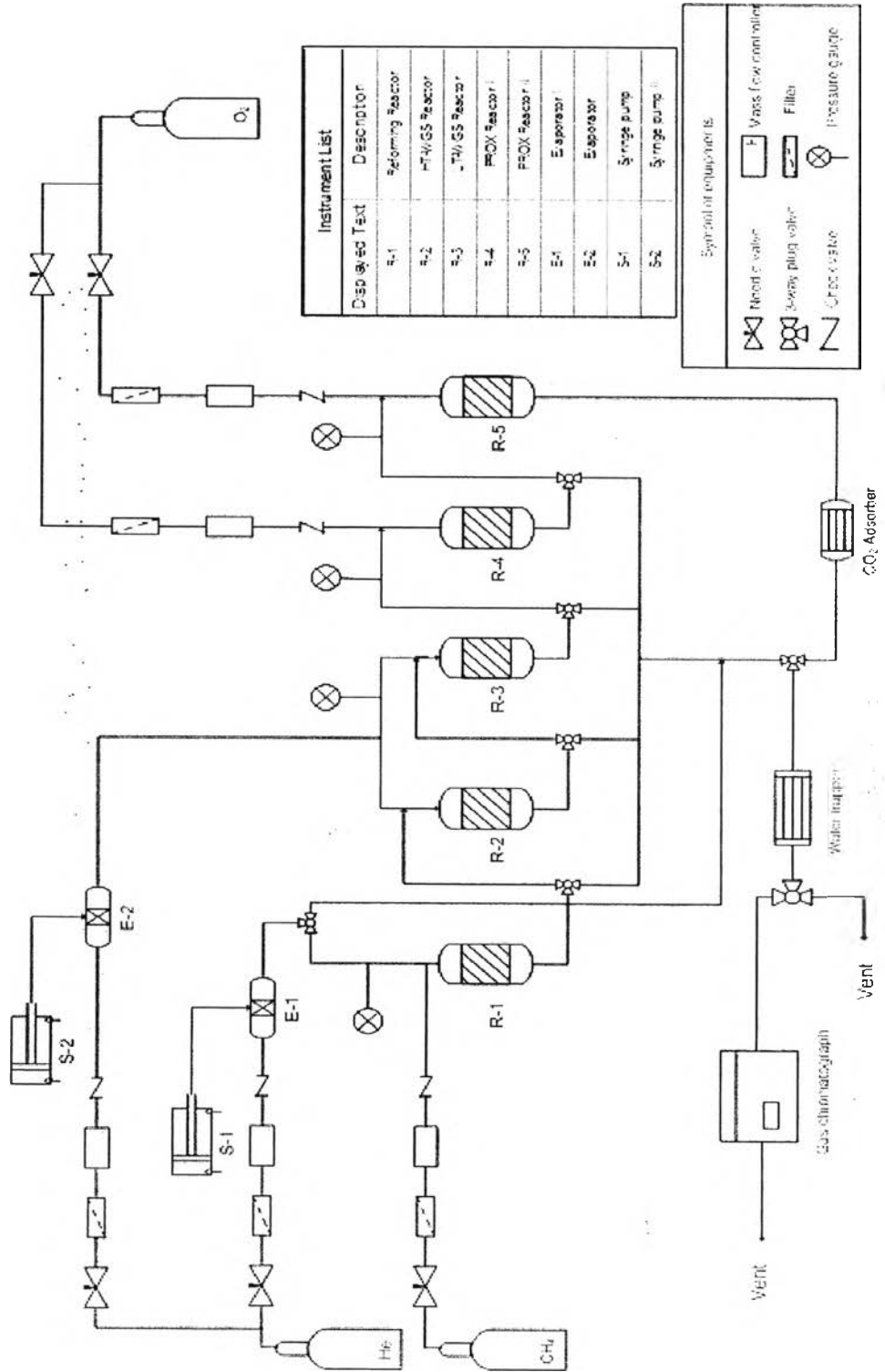

Figure 3.2 Schematic of fuel processor system.

3.3 Catalyst Preparation Procedure

The gold catalysts (Au/FeO_x, Au/MnO_x, and Au/FeO_x-MnO_x) were prepared by deposition precipitation (DP) technique (Au/FeO_x, Au/MnO_x, and Au/FeO_x-MnO_x). The supports (FeO_x, and MnO_x) were prepared by precipitation technique whereas the FeO_x-MnO_x were prepared by co-precipitation (CP) technique.

3.3.1 Support Preparation

3.3.1.1 Preparation of FeO_x-MnO_x Support

The FeO_x-MnO_x was prepared using the by co-precipitation from a mixture of 1M Na₂CO₃, 0.1M Mn(NO₃)₂, and 0.1M Fe(NO₃)₃ under efficient stirring condition at 80°C. The mixture was kept at a pH of 8 for 1 h. The precipitate was separated out from solution by centrifuge HERMLE Z383 at 2,000 rpm for 5 min. Excess ions, NO₃⁻ and CO₃²⁻, were eliminated by washing with warm deionized water. Deionized precipitate was dried at 110°C overnight and calcined 400°C for 4 h. Finally, deionized precipitate was ground and sieved to 80-120 mesh size and kept in a desiccator.

3.3.1.2 Preparation of FeO_x Support

The aqueous mixture of 0.1M Fe(NO₃)₃ was added into an aqueous solution of 1M Na₂CO₃ under vigorous stirring condition at 80°C. The mixture was kept at a pH of 8 for 1 h. Excess ions, NO₃⁻ and CO₃²⁻, were eliminated by washing with warm deionized water. The precipitate was dried at 110°C overnight and calcined in air at 400°C for 4 h. After calcination, the sample was labeled and kept in a desiccator.

3.3.1.3 Preparation of MnO_x Support

The aqueous mixture of 0.1M Mn(NO₃)₂ was added into an aqueous solution of 1M Na₂CO₃ under vigorous stirring condition at 80°C. The mixture was kept at a pH of 8 for 1 h. Excess ions, NO₃⁻ and CO₃²⁻, were eliminated by washing with warm deionized water. The precipitate was dried at 110°C overnight and calcined in air at 400°C for 4 h. After calcination, the sample was labeled and kept in a desiccator.

3.3.2 Catalyst Preparation

3.3.2.1 Preparation of Au/FeO_x-MnO_x Catalysts

Hydrogen tetrachloroaurate (III), H₂AuCl₄·3H₂O, was weighed for a desired amount, and then dissolved in deionized water under continuous stirring at 80°C. The dried support was added to the solution and the pH of solution (~8) was adjusted by adding 0.1 M Na₂CO₃, then the mixture was kept for 1 h. The suspension was washed by warm deionized water to eliminate the residue ions. The suspension was centrifuged in centrifuge HERMLE Z383 at 2,000 rpm for 5 min. Deionized precipitate was dried at 110°C overnight and calcined in air at various temperatures for 4 h. After calcination, the sample was ground and sieved to 80–120 mesh size, and kept in a desiccator.

3.3.2.2 Preparation of Au/FeO_x Catalysts

Hydrogen tetrachloroaurate (III), H₂AuCl₄, was weighed for a desired amount, and then dissolved in deionized water under continuous stirring at 80°C. The dried support was added to a solution and the pH of solution (~8) was adjusted by adding 0.1M Na₂CO₃ then the mixture was kept for 1 h. The suspension was washed by warm deionized water to eliminate the residue ions. Deionized precipitate was dried at 110°C overnight and calcined in air at various temperatures for 4 h. After calcination, the sample was ground and sieved to 80–120 mesh size, and kept in a desiccator.

3.3.2.3 Preparation of Au/MnO_x Catalysts

Hydrogen tetrachloroaurate (III), H₂AuCl₄, was weighed for a desired amount, and then dissolved in deionized water under continuous stirring and heating at 80°C. The dried support was added to a solution and the pH of solution (~8) was adjusted by adding 0.1 M Na₂CO₃ and the mixture was aged for 1 h. The suspension was washed by warm deionized water to eliminate the residue ions. Deionized precipitate was dried at 110°C overnight and calcined in air at various temperatures for 4 h. After calcination, the sample was ground and sieved to 80–120 mesh size, and kept in a desiccator.

3.4 Catalyst Characterization

The properties and characteristics of the prepared catalysts (Au/ FeO_x-MnO_x) are different due to the effect of Au content, supported molar ratio, calcination temperature and gas pretreatment. The different properties may affect the activities and selectivity of the catalyst; therefore, it is necessary to conduct some characterizations. In this work, several characterizations are utilized.

3.4.1 BET Surface Area Measurement

One of the most important properties of heterogeneous catalyst is its surface area since the reaction take place on the catalyst surface. The determination of surface area and pore size of catalysts was done by Autosorb-1 Gas Sorption system (Quantachrome Corporation). The equipment measurement is based on Brunauer-Emmet-Teller (BET) equation. This technique is done by calculating the physical multi-layer adsorption of N₂ gas with the cross-sectional area of 16.2x10⁻²⁰ m²/molecule. N₂ gas is adsorbed on the catalyst surface at liquid nitrogen temperature (-196°C). Prior to analysis all of samples were degassed by heating under vacuum at 150°C for 2 h to eliminate adsorbed species at surface. The surface area is calculated from the 22 points nitrogen adsorption. The average pore diameter and pore volume are obtained at P/P₀ ratios close to unity. The result is analyzed by Autosorb Anygas Software version 2.1, which are calculated using the BET equation, as shown in Equation 3.1.

$$\frac{1}{W \cdot \left(\frac{P_0}{P} - 1 \right)} = \frac{1}{W_m \cdot C} + \frac{(C-1)}{(W_m \cdot C)} \cdot \left(\frac{P_0}{P} \right) \quad (3.1)$$

where:

- P = pressure of gas,
 P_0 = saturated vapor pressure of the liquid at the operating temperature,

- W = weight of gas adsorbed at a relative pressure, P_0 ,
 W_m = weight of adsorbate constituting a monolayer of surface coverage, and
 C = constant that is related to the energy of adsorption in the first adsorbed layer and magnitude of the adsorbent/adsorbate interaction.

The surface area is calculated by Equation 3.2.

$$S = \frac{W_m \cdot A_{N_2} \cdot (6.02 \times 10^{23})}{M_{w,N_2}} \quad (3.2)$$

Where:

- S = specific surface area (m^2/g),
 A_{N_2} = cross-sectional area of one molecule N_2 ,
 = 0.162 nm^2 (-196°C), and
 M_{w,N_2} = molecule weight of nitrogen (28 g/g-mol).

3.4.2 X-ray Diffractometry (XRD)

The crystalline structure of oxide support and the mean particle diameter of gold were analyzed by means of a Rigaku X-Ray Diffractometer system (RINT-2200) with copper tube for generating $\text{CuK}\alpha$ radiation (1.5406 \AA) and nickel filter. It is also possible to achieve a relative analysis by the intensity of the peak. For the same crystalline substance the higher of the peak indicates the higher content of that phase.

RINT-2200 was used to obtain XRD pattern at a generator voltage of 40 kV and a generator current of 30 mA. The goniometer parameters are divergence slit = 1° (2θ); scattering slit = 1° (2θ); and receiving slit = 0.3 mm. The scan speed of 5° (2θ)/min with scan step of 0.02 (2θ) is used for the continuous run in 5 to 90°C

(2θ) range. Sample should be ground to the fine homogeneous powder and held in a beam in a thin-walled glass container. The signal is sent to the on-line computer to record and analyze. Scherrer equation in the form of Equation (3.3) shows the relationship between the crystalline thickness (D_b) and the broadening (B_d) of the diffraction line corresponding to the Bragg angle (θ) using wavelength (λ).

$$D_b = \frac{K \cdot \lambda}{B_d \cdot \cos \theta} \quad (3.3)$$

where:

D_b = mean crystalline diameter (\AA),

K = Scherrer constant, 0.9,

λ = X-Ray wavelength (\AA),

B_d = angle width of peak in term of $\Delta(2\theta)$ (radian), and

θ = Bragg angle of the reflection (degree).

3.4.3 Atomic Absorption Spectroscopy (AAS)

The AAS, VARIN model 300/400 was utilized to determine the actual percent Au loading on supports. A known weight amount of catalyst was dissolved in aqua regia solution compose of hydrochloric acid and nitric acid with a ratio of 82:18 and then heated to 100°C for one hour. Several standard solutions were made from stock solution of 1,000 ppm to establish a calibration curve. By measuring the absorbance of the prepared solution the amount of Au loaded on the supports were obtained.

3.4.4 Transmission Electron Microscopy (TEM)

The most widespread application of transmission electron microscopy in the catalytic research is in measurement of size distributions of supported particles in order to determine from the dispersion of the (usually) active phase. In this work, TEM was used to investigate the average crystallite size of Au. The TEM was carried

out by using a JEM 2010 operating at 200 kV in bright and dark field modes. More or less parallel electron beam uniformly irradiated the part of studied specimen. The transmitted beam was focused by the objective lens and then propagated through several subsequent lenses. Diffraction pattern and the image of the specimen were observed from selected area. The way to prepare catalysts in a thin form suitable for TEM is to crush and grind the samples in a mortar. The fine powder thus obtained was dispersed in ethanol by use of an ultrasonic bath, and drop of the suspension was deposited on a thin carbon film supported on a standard electron microscope grid. The average Au size diameter (d_{TEM}) was calculated from the following formula: $d_{\text{TEM}} = \Sigma(n_i d_i) / n_i$ where n_i is the number of Au particles of diameter d_i .

3.4.5 Temperature-Programmed Reduction (TPR)

Temperature-Programmed Reduction (TPR) was conducted using an in-house TPR system. A measurement was carried out by placing a sample in a quartz reactor. The sample was subjected to TPR analysis using 10% H₂ in Ar at a total flow of 30 ml/min. The reduction temperature was raised from 30 to 850°C with a ramp rate of 10°C/min. A thermal conductivity detector was used to monitor the difference of hydrogen content before and after the reduction. The temperature, at which the reduction was completed, could be determined from TPR pattern.

3.4.6 UV-vis Spectrophotometry

Diffuse reflectance spectra were recorded by UV-vis spectrophotometer-2550 by using light in the visible and adjacent near ultraviolet (UV) and near infrared (NIR) ranges, used in the quantitative determination the transition metal ions. The samples were packed in the sample holder and analyzed by limiting wavelength in the range of 800–200 nm. And the data would be converted using Kubelka-Munk formula.

3.5 Activity Measurement

The reaction was carried out in the fixed-bed reactor as described previously packed with 100 mg catalyst of 80–120 mesh in size. The feed gas consisted of 1% CO, 1% O₂, and 40% H₂ balanced in He passing through the catalyst bed at the total flow rate of 50 ml/min (SV=30,000 mlg⁻¹h⁻¹) under atmospheric pressure.

3.5.1 Effect of Au Loading

The amount of Au loaded onto the support has the significant effect on the catalyst activity. In this work, the atomic ratio of Au/support over Au/FeO_x-MnO_x, the ratio of 1/30, 1/45, 1/60, and 1/120 was investigated.

3.5.2 Effect of Support Molar Ratio

In the case of Au/FeO_x-MnO_x catalysts, the effect of FeO_x-MnO_x ratios on the catalyst activity was studied. The FeO_x-MnO_x ratios were varied with 10:1, 5:1, 1:1, 1:5, and 1:10 molar ratio of FeO_x to MnO_x.

3.5.3 Effect of Calcination Temperature

In the preparation procedure, calcination was the last step to form the catalyst structure. Nevertheless, different calcination temperatures, different catalyst morphologies could lead to different activities.

The calcination temperature was varied with different kinds of catalysts. For Au/FeO_x-MnO_x, the catalysts were calcined at 300, 400, and 500°C for 4 h.

3.5.4 Effect of Catalyst Pretreatment

Pretreatment may cause some changes in the structure of the catalyst leading to the changes in the activity and selectivity. Thus, two catalyst pretreatment procedures on the catalyst activity were compared.

- The first one, sample was heated to 110°C and kept for 1 h under 30 ml/min of He flow, then the temperature was adjusted cooled down to the reaction temperature.

- The second one, sample was heated to 110°C and keep for 2 h under 30 ml/min of O₂ flow, then the temperature was adjusted cooled down to the reaction temperature.

3.5.5 Deactivation Test

Finally, the best catalyst was determined to check whether it still keep the high activity in the long time or not in order to be commercially usable. The influence of CO₂ and H₂O on the PROX of CO activity in simulated reformat are investigated.

3.5.5.1 Effect of H₂O Concentration in the Feed Gas

Ordinarily, the catalyst activity is depressed in the presence of H₂O as a result of the blocking active site of this catalyst (Daté *et al.*, 1997). Therefore, the effect of water concentration on the catalytic activity of prepared catalyst was carried out by adding 10% of H₂O in the feed gas.

3.5.5.2 Effect of CO₂ Concentration in the Feed Gas

Hoflund *et al.* (1995) and Srinivas *et al.* (1996) found that CO₂ in the reactant gas mixture adversely affect the behavior of catalyst due to CO₂ retention, and formation carbonates on their surfaces which prevent O₂ adsorption and O₂ splitting on catalyst surface. The effect of CO₂ (10% CO₂) in feed gas on the catalytic activity was investigated.

3.6 Calculation

The effluent gas from the reactor is analyzed by auto-sampling in an on-line gas chromatograph using He as the carrier gas. The CO conversion and O₂ conversion are calculated based on the consumption of reactant gases along the preferential CO oxidation reaction. The CO selectivity was defined by the O₂ consumption for the desired CO oxidation reaction over the total O₂ consumption.

$$X_{CO} = \frac{[CO]_o - [CO]}{[CO]_o} \times 100 \quad (3.4)$$

$$X_{O_2} = \frac{[O_2]_o - [O_2]}{[O_2]_o} \times 100 \quad (3.5)$$

$$S = \frac{[O_2]_{CO}}{[O_2]_{CO} + [O_2]_{H_2}} \times 100 \quad (3.6)$$

where:

X = CO conversion (%),

S = selectivity (%),

[CO]_o = concentration of CO in the reactant gas,

[CO] = concentration of CO in the product gas,

[O₂]_o = concentration of O₂ in the reactant gas,

[O₂] = concentration of O₂ in the product gas,

[O₂]_{CO} = amount of O₂ for CO oxidation and

[O₂]_{H₂} = amount of O₂ for H₂ oxidation.