

CHAPTER II

EXPERIMENTAL SECTION

2.1 Materials

2.1.1 PP

PP1 ; Polypropylene grade 1102 H obtained from Thai Petrochemical Industry Co., Ltd. was used as a matrix. Melt flow index was measured according to the ASTM D1238 and found to be 1.8 g/10 min at 230°C. The molecular weight is 840,000.

PP3 ; Polypropylene grade 1100 PK obtained from Thai Petrochemical Industry Co., Ltd. was used as a matrix. Melt flow index was measured according to the ASTM D1238 and found to be 15 g/10 min at 230°C. The molecular weight is 420,000.

2.1.2 Kunipia F

Kunipia F is a type of clay supplied by Kunimine Industry. It is a Na⁺ type montmorillonite, with a cation exchange capacity 119 mequiv/100 g. Its structure consists of stacking of silicate sheets with thin square plate shape whose its dimension is about 2000 Å in length and 10 Å in thickness.

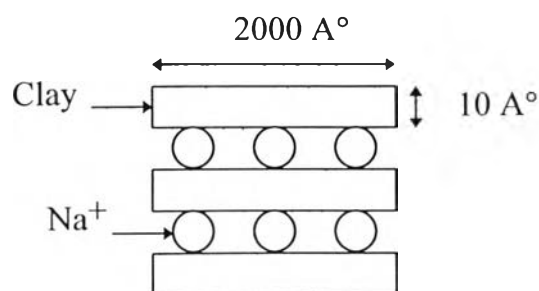

Figure 2.1 Structure of Na⁺ montmorillonite.

2.1.3 Maleic Anhydride Modified Polypropylene (MAPP)

Maleic anhydride modified polypropylene (MAPP) grade 3002 supplied by Uniroyal Co., Ltd. was used as the tie molecules. The maleic anhydride group in MAPP can react with amino group in modified silicate clay and polypropylene chain in MAPP can entangle with the polypropylene matrix of the composites. The appearance of MAPP is white pellets with the melting point 160°C. It contains 0.62% maleic anhydride content. The melt flow index is 9.03 dg/min. It can not be soluble in water but it can be soluble in xylene at 125°C.

2.1.4 3-Aminopropyl Dimethylethoxysilane

3-aminopropyl dimethylethoxysilane supplied by United Chemical Technology was used as the silane coupling agent. Its molecular weight is 161.32 and its specific gravity is 0.857. Its structure is shown in Figure 2.2.

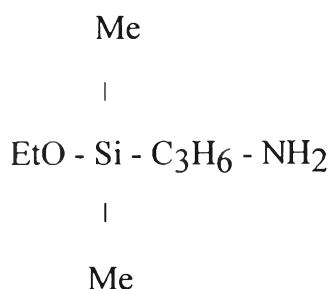

Figure 2.2 Structure of 3-aminopropyl dimethylethoxysilane.

Note* This silane coupling agent is easily hydrolysed when attacked by water or moisture. This hydrolysis can make silane inactive. So, the silane coupling agent should be kept carefully in a refrigerator.

2.1.5 Solvents and Chemicals

- Ethanol (AR grade) supplied by BDH Laboratory Supplies was used with water and the aminosilane coupling agent to prepare the modified silicate clay. Its molecular weight is 46.07. Its boiling point is 78.5 °C and its density is 0.7896 g/cm³.

- Dimethylacetamide (DMAc) (AR grade) supplied by Lab Scan Ltd. was used as a good dispersant for the modified silicate clay. Its formula weight is 87.12 and its boiling point is 166.1°C.

- Xylene (AR grade) supplied by Lab Scan Ltd. was used as the solvent for PP at 125°C. Its formula weight is 106.17 and the boiling point is 130-140°C.

- Tetrahydrofuran (THF) (AR grade) supplied by Lab Scan Ltd. was used for precipitating nanofiller. Its boiling point is 64.5°C and its density is 0.889.

2.2 **Nanocomposite Preparation**

2.2.1 Nanofiller Preparation

There are two methods to prepare the nanofiller.

2.2.1.1 Old Method.

(1) The grafting of aminosilane coupling agent to the silicate clay.

The silane coupling agent (2% of silane coupling agent with respect to clay), 3-aminopropyl dimethylethoxysilane, was stirred in the mixture of 95% ethanol in water for 1 hour at room temperature to hydrolyze the silane coupling agent. The clay powder was put in the silane coupling agent

solution and vigorously stirred at room temperature for 30 min. Then, the treated clay was dried in a hot air oven at 50°C for 48 hours.

Silanol preparation

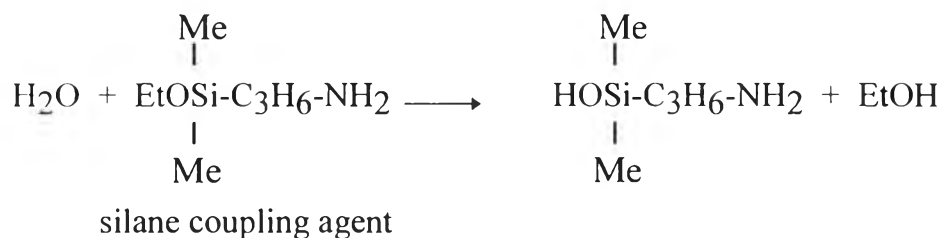

The grafting of aminosilane to silicate clay

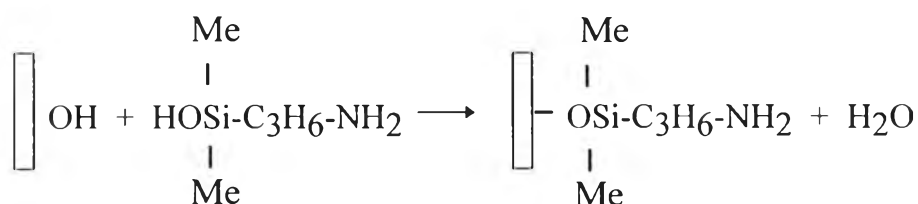

Silicate Clay

Modified Silicate Clay

(2) The grafting of MAPP to the modified silicate clay.

The modified silicate clay was dispersed in dimethylacetamide (DMAc) at 90°C and stirred for 3 hours (by using 3% of clay with respect to DMAc). MAPP was dissolved in hot xylene at 125°C for 20 min (by using 10% of MAPP in xylene). The grafting of MAPP to the modified silicate clay occurred in the solution reaction by mixing the dispersed clay solution and the dissolved MAPP solution at 125°C for 30 min. Then, the filler was precipitated with tetrahydrofuran (THF) at room temperature about 30 min and dried at 50°C for 24 hours. This filler was ground by centrifugal ball mill (model S-1/2) about 5 hours (in each batch, the filler was put in centrifugal ball mill about 10 grams).

The reaction between modified silicate clay and MAPP

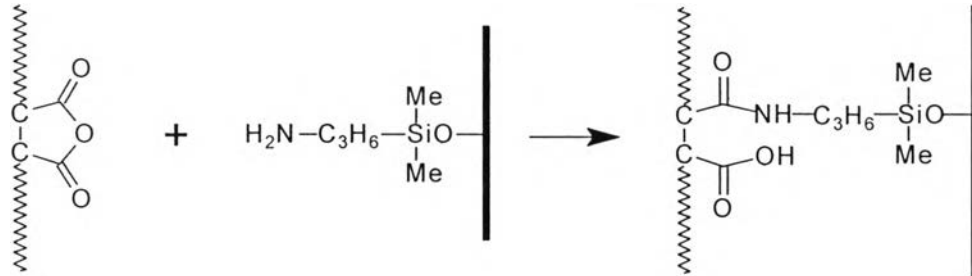

MAPP

Modified Silicate Clay

Nanofiller

2.2.1.2 *New Method.* In the old method, the dimer of silane that makes silane inactive may occur in silanol preparation.

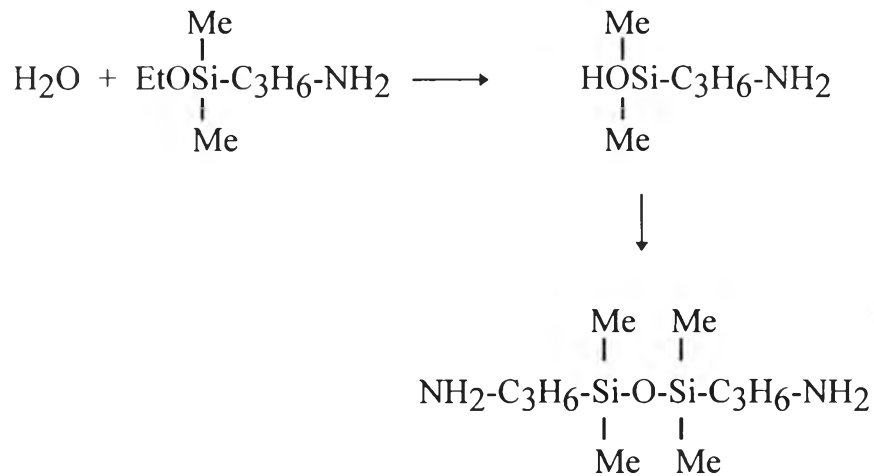

So, the new method was proposed by using the following procedure. The dimethylacetamide (DMAc) was heated to 80°C. Then, clay was added in dimethylacetamide and heated to 90°C (by using 3% of clay with respect to DMAc). The 2% of silane coupling agent (with respect to clay) was added in dispersed clay solution and stirred at 90°C for 3 hours. MAPP was dissolved in xylene at 125°C for 20 min (by using 10% of MAPP with respect

to xylene). The reaction between the modified clay and MAPP occurred in solution reaction by mixing the dispersed clay solution and the dissolved MAPP solution at 125°C and stirring for 30 min. Then, the filler was precipitated with THF for 30 min at room temperature and dried at 50°C for 24 hours. Then, the filler was ground by centrifugal ball mill (model S-1/2) about 5 hours (in each batch, the filler of 10 grams was put in centrifugal ball mill).

The grafting of aminosilane to silicate clay

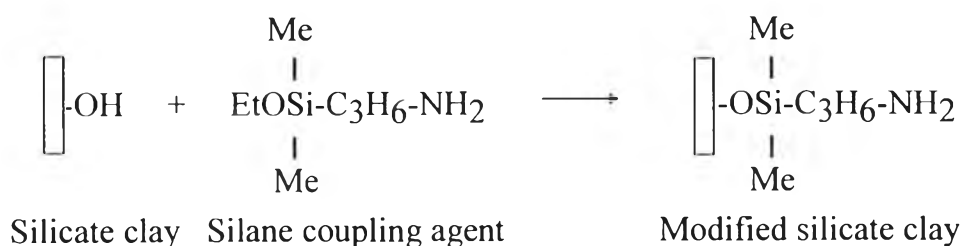

The reaction between modified silicate clay and MAPP

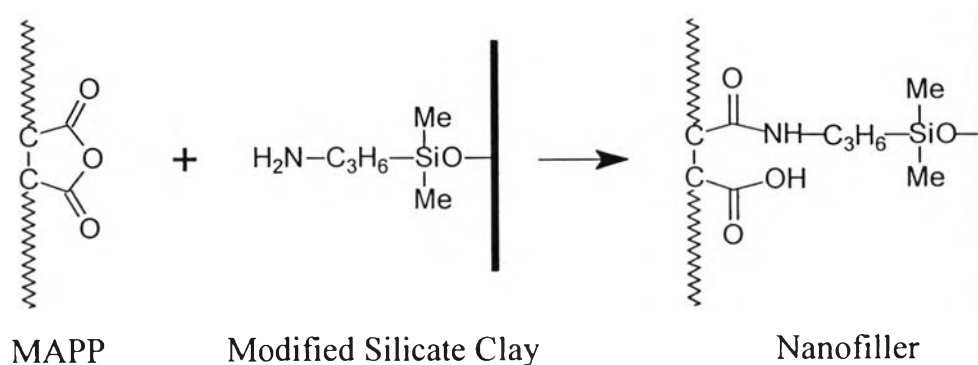

Flow Charts of Preparation Methods

The Old Method

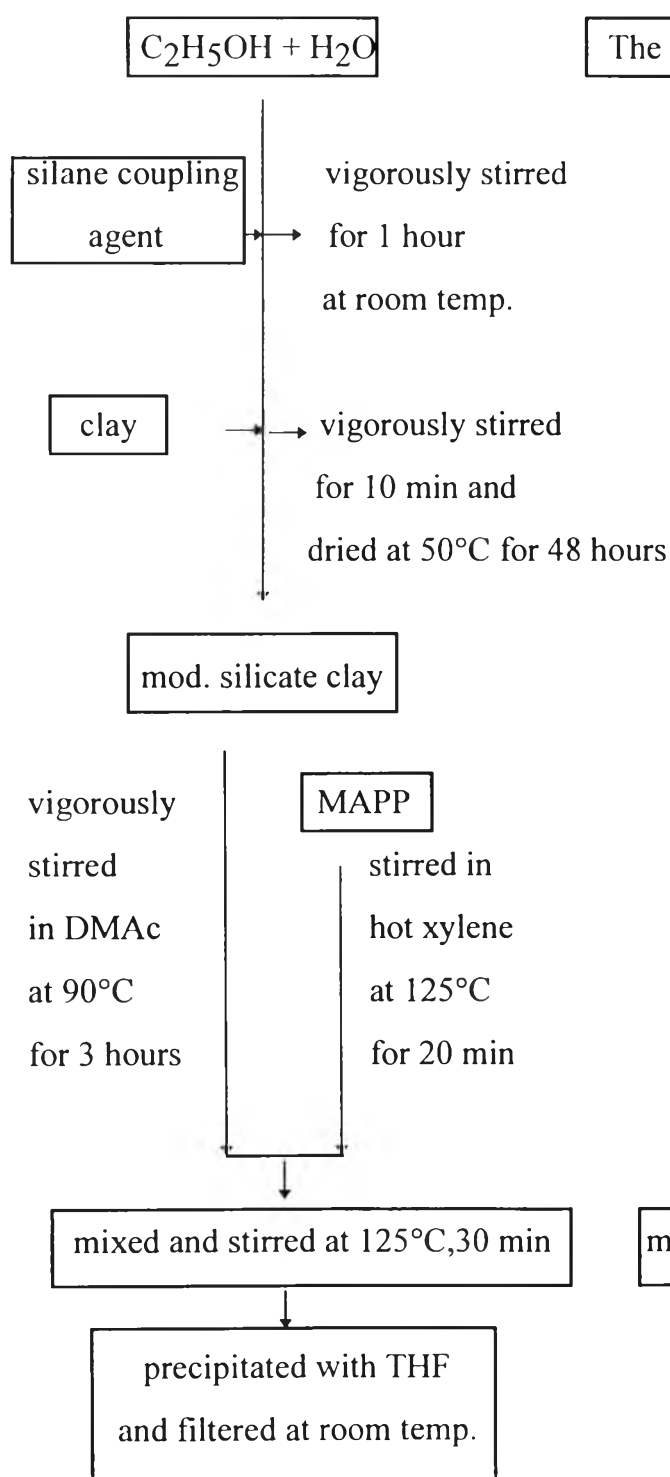

The New Method

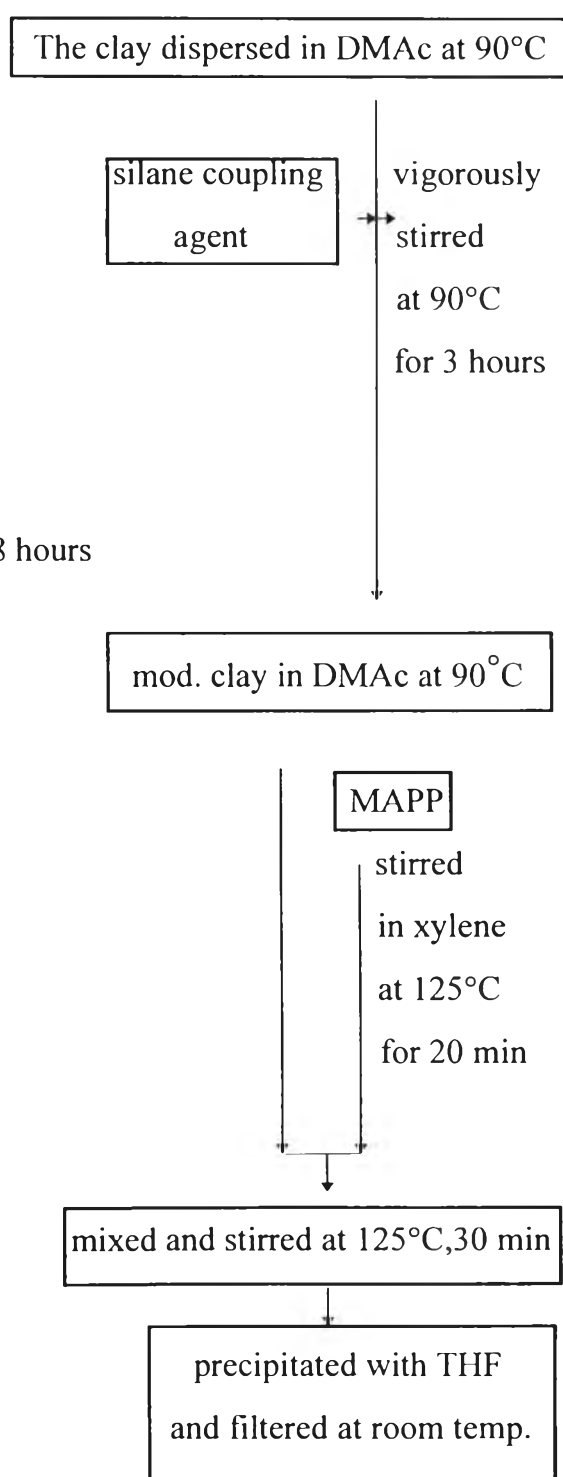

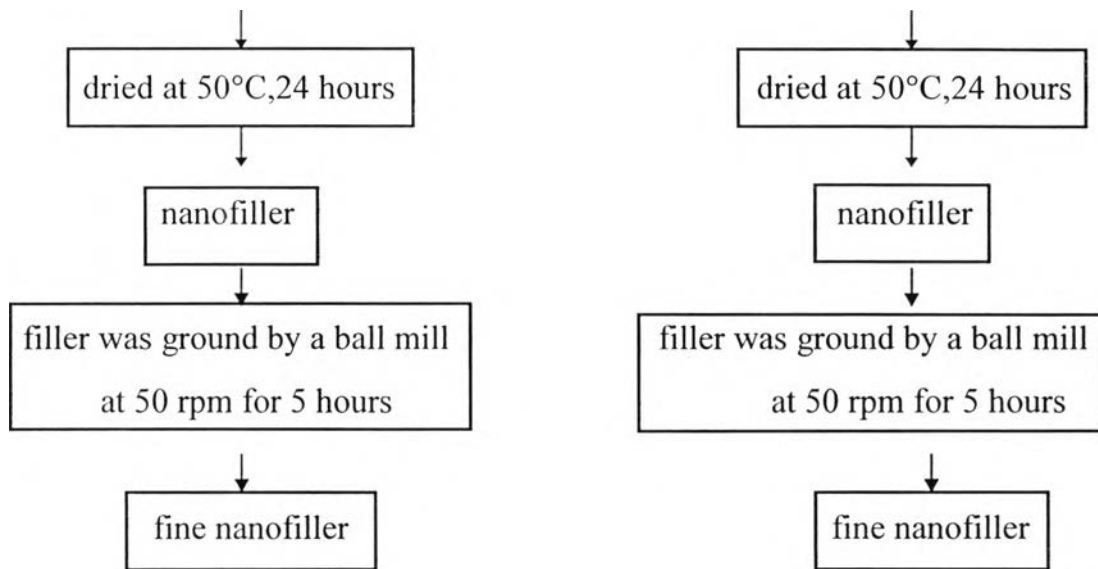

2.2.2 Nanocomposite Preparation

The nanocomposite was prepared by melt blending process between PP and nanofiller using a Lab Tech two roll mill (model LRM 110) at speed of 33 rpm ; the diameter of the roll was 11.14 cm and the gap between the roll was 0.60 mm. The temperature of front roll was 170°C and the temperature of back roll was 160°C. First, the PP matrix was put on the two roll mill for about 5 min until the PP melted. Then, the nanofiller was added gradually onto the roll and processed for about 20 min. The material was removed from the two roll mill and ground by a shredder (model K210S) for 3 times until the composite became the granular size. The materials from the shredder were pressed on a compression mould wabash (model V50H-18-CX) at 200°C. Each sample was heated between the press plaques for 15 min. Then, the sample were cooled to room temperature. The entire cooling process took about 5 min. The dimensions of the sheet were $9.6 \times 14.7 \times 0.3 \text{ cm}^3$ for the impact testing and $12.7 \times 14.7 \times 0.2 \text{ cm}^3$ for tensile and slow crack growth testing.

Flow Chart of Preparation of the Nanocomposite

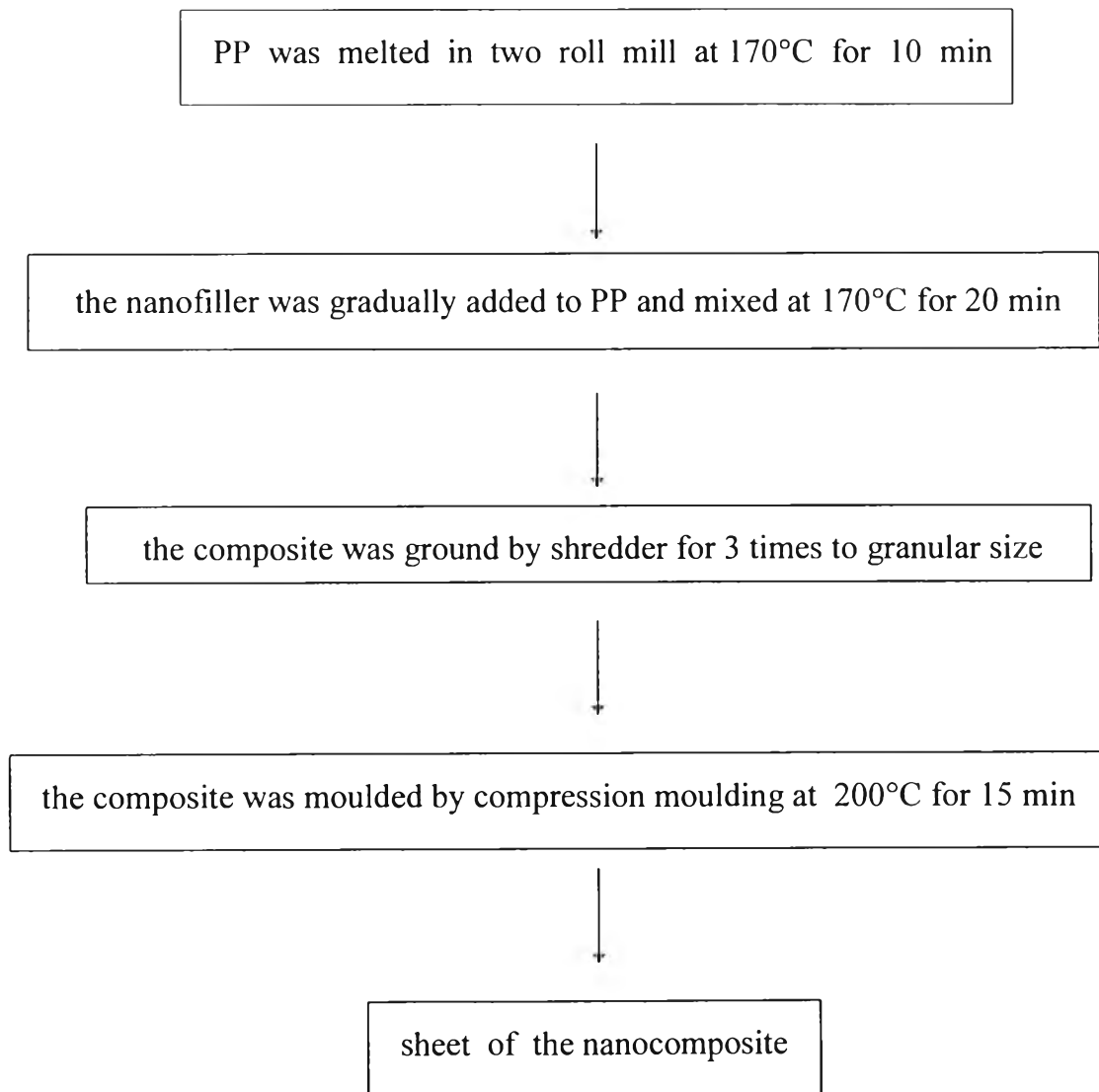

After getting the plaque specimen, the specimen was cut for the required dimension for each testing.

Tensile Testing

Following ASTM D638-91 Type 1 for specimen dimensions, the specimen were machined into dogbone shape.

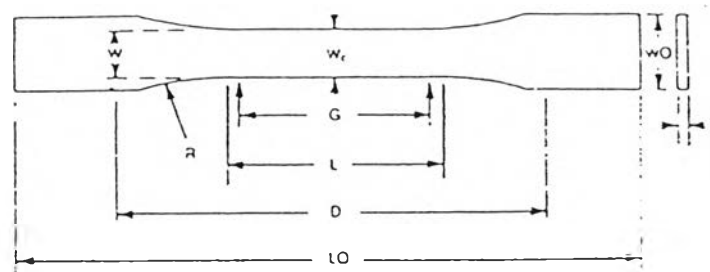

Figure 2.3 Dimensions of tensile testing specimen.

Table 2.1 Dimensions of tensile testing specimen as shown in Figure 2.3

Definition	Dimensions (mm)
W - Width of narrow section	13
L - Length of narrow section	57
W ₀ - Width over-all	19
LO - Length over-all	165
G - Gage length	50
D - Distance between grips	115
R - Radius of fillet	76
T - Thickness	14

Impact Testing

Izod impact testing was done with a notch specimen according to D256-92.

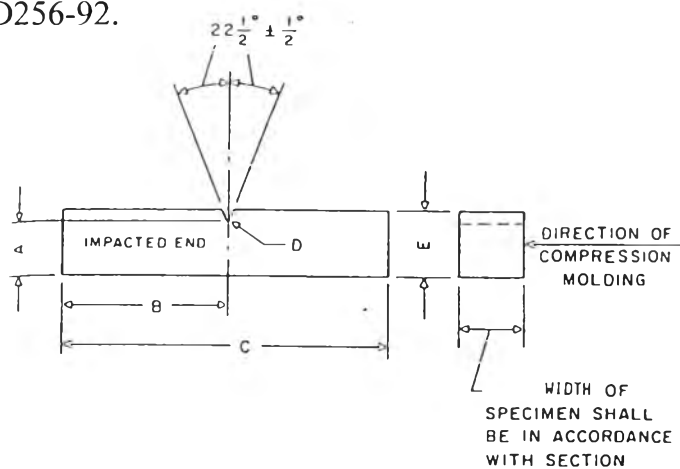

Figure 2.4 Dimensions of Izod impact testing specimen.

Table 2.2 Dimensions of Izod impact testing specimen

	Dimensions
A	10.16±0.05
B	32.00 max, 31.50 min
C	63.50 max, 60.30 min
D	0.25R±0.05
E	12.70±0.15

Slow Crack Growth Testing

The specimen of slow crack growth testing was prepared by Brown's procedure [1992] in Figure 2.5.

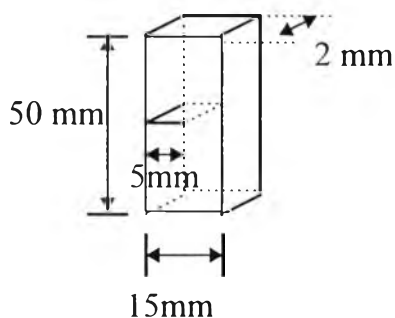

Figure 2.5 Dimensions of slow crack growth testing specimen.

Figure 2.5 shows a sketch of the specimen taken from a compression moulded resin. The dimensions of the specimens for the slow crack growth testing were $15 \times 50 \times 2 \text{ mm}^3$. The notch was introduced by pressing a fresh razor blade into the specimen. Each specimen had a 5 mm notch.

2.3 Characterization Techniques

2.3.1 X-Ray Diffraction Spectroscopy (XRD)

X-ray diffraction was used to measure the intensity versus the diffraction angle of 2θ from 2° to 30° on a X-ray diffractometer (model Philips PW3710). The diffractometer was equipped with a $\text{CuK}\alpha$ radiation source operated at 40 kV and 30 mA. The scanning speed and the step size were 1° /min. Si was used as the calibration standard. The sample of x-ray diffraction spectroscopy is a powder. In this thesis, the modified silicate clay and nanofiller powder were x-rayed for the d-spacing to confirm the treatment of clay by silane coupling agent and MAPP.

2.3.2 Diffuse Reflectance Infrared Spectroscopy (DRIFT)

Diffuse reflectance infrared (DRIFT) spectra were taken using a Bio-rad FTIR (model FTS-45A). The sample were analyzed against a KBr powder reference. DRIFT spectra were taken at resolution of 2 cm^{-1} with 16 coadded scans. All DRIFT spectra are plotted according to the Kubelka- Munk function. The specimen of this technique was fine powder. In this work, the absorbance versus frequency of the nanofiller powder was measured.

2.3.3 Transmission Electron Microscopy (TEM)

Transmission electron micrograph was obtained with JEOL JEM with model 200 CX using acceleration voltage of 100 kV. The stain on the sample was prepared by dissolving 2% (w/v) solution of $\text{RuCl}_3 \cdot 3\text{H}_2\text{O}$ in sodium hypochlorite for 3 hours [Montezinos, 1985].

2.4 **Mechanical Testing**

2.4.1 Tensile Testing

The tensile properties were studied using the Instron Universal Testing Machine model 4206 in the extension mode. The tensile strength at yield, the young's modulus and the % elongation at yield and % elongation at break were determined according to ASTM D638-91. The testing temperature was 26°C . The specimen were machined into dogbone shapes following the ASTM D638-91 type I for specimen dimensions, the width of narrow section was 13 mm and the gage length was 50 mm as in Figure 2.3. The tests were performed at a crosshead speed of 50 mm/min with a 5 kN load cell.

The tensile strength at yield is maximum tensile stress at yield point sustained by specimen during a tension test. It can be calculated by dividing the maximum load at yield point by original cross-sectional area.

The tensile modulus using in this thesis is auto young's modulus; that is the steepest linear region at the start of the testing curve and ends it at the yield point. It can be defined by dividing the corresponding stress by the designated strain.

The % elongation at yield and at break are the extension (change in gage length) at yield point and at break are reached. It can be calculated by dividing the extension by original gage length and multiplied by 100.

2.4.2 Impact Testing

Izod impact testing was done at 26°C with a notch specimen according to the specification of ASTM D256-92. The specimen was held as a vertical cantilever beam and was broken by a single swing of the pendulum with the line of initial contact at a fixed distance from the specimen clamp. By using Izod type, Zwick, the impact pendulum was a 2.7 joule pendulum. The specimens were machined from the composite plaques and cut into 12.75×63.5 mm and 2.5 mm notch was carved into them by a notching machine. Impact strength is the property of the material in resisting failure when subjected to a rapidly increasing applied force. It is expressed as the impact energy which is the energy absorbed by the object during fracture at a very high testing rate.

2.4.3 Slow Crack Growth Testing

The testing method followed that of Chanintra's procedure [1996]. The specimen taken from a compression molded resin. The specimen was machined followed the dimensions in Figure 2.5. The notch was introduced by pressing a fresh razor blade into the specimen. A fresh razor blade should not

be used for more than about four specimens. Each specimen has a gap of 5 mm notch. Gripping the specimen was the most important step. The grips must be aligned and centered with respect to the longitudinal axis of the specimen. The constant load tensile test was conducted under 9 MPa stress at 60°C. The temperature was carefully controlled within ± 1 . It is not recommended that polyolefins should be tested above 80°C because significant morphological changes can occur during the test. The rate of slow crack growth is monitored through a Zoom stereo microscope (model SZ4045TR) with 80 \times magnification by measuring the crack opening displacement and the crack length versus time.

The crack opening displacement (COD) is the value of the separation distance at the initial notch tip. The crack length (CL) is the average distance of the trace of the crack with respect to the initial notch tip.

Before Testing

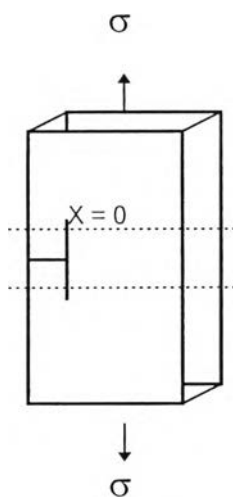

After Testing

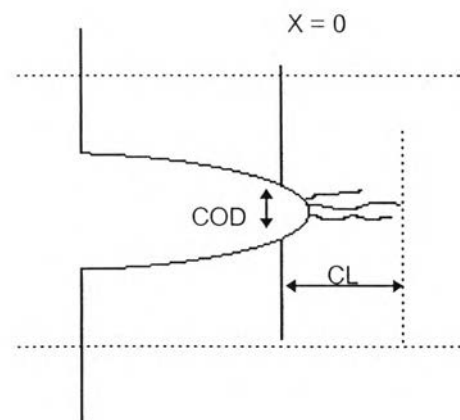

Figure 2.6 Specimen of slow crack growth test.

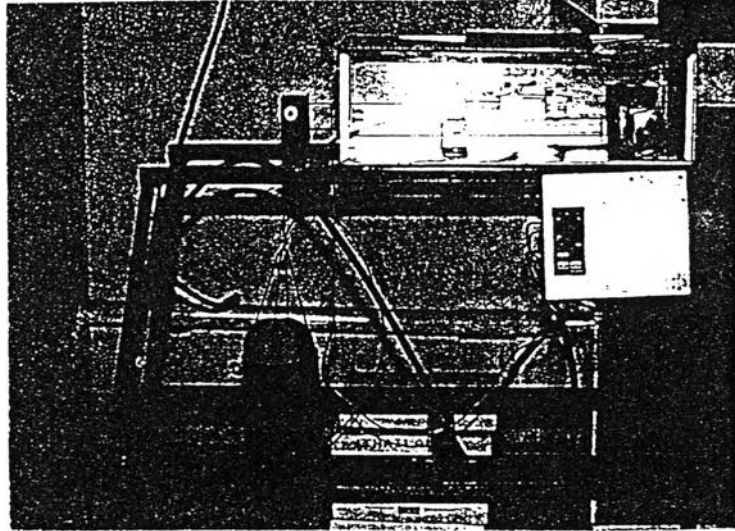

Figure 2.7 Our homemade SCG apparatus.

2.5 Scope of Experiment

The scope of experiment in this work is shown in Table 2.3:

Table 2.3 Scope of experiment

Experiment	Tensile Test	Impact Test	SCG Test
Effect of two methods by varying clay content	PP3/2/y/10	PP3/2/y/10	-
Effect of filler content	PP1/2/10/z, PP1/2/60/z, PP1/2/100/z	PP1/2/10/z, PP1/2/60/z, PP1/2/100/z	-
Effect of MW of PP matrix by varying clay content	PP3/0/0/10, PP3/15/5/10, PP3/8/8/10, PP3/4/20/10, PP3/2/40/10, PP3/2/60/10, PP3/2/80/10, PP3/2/90/10, PP3/2/95/10, PP3/2/100/10	PP3/0/0/10, PP3/15/5/10, PP3/8/8/10, PP3/4/20/10, PP3/2/40/10, PP3/2/60/10, PP3/2/80/10, PP3/2/90/10, PP3/2/95/10, PP3/2/100/10	PP1, PP1/2/20/10, PP1/2/60/10, PP3, PP3/2/20/10, PP3/2/60/10

Notations

y = 0, 2, 5, 10, 20, 40, 60, 80

z = 0, 2, 5, 10, 20, 30

S/C/F = wt % silane coupling agent content in the silicate clay/
wt % clay content in the filler/
wt % filler content in the composite

For example, PP/S/C/F: PP1/2/y/10 means that this composite used PP1 as a polymeric matrix and contains 10 wt % of filler content in the composite and the clay content is varied at the fixed amount of 2 wt % silane concentration used in the modification of silicate clay.