

CHAPTER III

EXPERIMENTAL

3.1 Materials

3.1.1 Chemicals for Catalyst Preparation

All chemical used for catalyst preparation and analytical procedures are described as follows:

- 1) Silver nitrate (AgNO_3), assay 99.9%, obtained from ITALMA (Thailand) Co., Ltd., was used as silver catalyst precursor.
- 2) Triton-x-100 obtained from Sigma Alodrich Co., USA. Was used as surfactant.
- 3) Glass plate (SiO_2) was used as catalyst support.

3.1.2 Reagent Gases for Reaction Experiment

All gases used for reaction were obtained from Thai Industril Gas Co., Ltd. as follow:

- 1) Helium (HP grade)
- 2) 40% ethylene balanced with helium.
- 3) 97% oxygen balanced with helium.
- 4) 30% Ethylene oxide balanced with helium.

3.2 Catalyst Preparation Procedures

The preparations method was consisted of three consecutive steps including glass plate preparation, silver nitrate aqueous solution preparation and Ag coated preparation. For the first step, glass plate was washed by distilled water followed by acetone and then dried in an oven at 100°C for 1 hour. For the second step, AgNO_3 was diluted with distilled water and mixed with Tritron-x-100 and after that would gave the silver nitrate aqueous solution, For the last step, The treated glass plate was coated with an aqueous silver nitrate solution to achieve silver loading from 5, 10, 15, and 20 wt.%. The mixture was then dried in an oven at 110 °C overnight. The catalysts was calcined at 500 °C for 5 h. in an oven

3.3 Catalyst Characterization Techniques

The characteristics of the prepared catalyst is determined with regard to their physical and chemical properties. The catalyst characterization techniques applied in this research are surface area analysis (BET), X-ray diffraction (XRD), field emission scanning electron microscopy (FE-SEM) with energy dispersive x-ray spectroscopy (EDX), and temperature-programmed oxidation (TPO).

3.3.1 BET Surface Area Measurement

The surface areas of all prepared catalysts is determined by measuring the quantity of gas adsorbed onto or desorbed from their solid surface at some equilibrium vapor pressure by the static volumetric method. The solid sample is maintained at a constant temperature in the sample cell until the equilibrium is established. This volume-pressure data is used to calculate the BET surface area.

The BET surface area measurement was performed by using a surface area analyzer (Quantachrome, Autosorb I). A catalyst sample was first outgassed to remove the humidity and volatile adsorbents adsorbed on the sample surface under vacuum at 150 °C for 10 h before starting the analysis. Autosorb ANYGAS Version 2.10 is also used to analyze the results.

The adsorption data is calculated by using the Brunauer-Emmett-Teller (BET) equation.

$$\frac{P}{V(P_0 - P)} = \frac{1}{V_m c} + \frac{(c-1) P}{V_m c P_0}$$

where

V = The volume of gas adsorbed

P = The pressure of gas

P_0 = The saturated vapor pressure of the liquid at the operating temperature

V_m = The volume equivalent to an adsorbed monolayer

c = The constant related to the energy of adsorption in the first adsorbed layer, the magnitude of adsorption in the first adsorbed layer, and the magnitude of adsorbate/adsorbent interaction, which is given by:

$$c = \exp\left(\frac{H_i - H_L}{RT}\right)$$

where

H_i = Heat of adsorption;

H_L = Latent heat of evaporation;

R = Gas constant

T = Temperature of adsorption.

The surface area can be determined by using the following equation:

$$S_g = \frac{V_m}{0.0224} (6.02 \times 10^{23})(A)$$

where

S_g = The specific surface area (m^2/g); and

A = The area occupied by one adsorbate molecule (m^2)

V_m = The area occupied by one adsorbate molecule (m^3 gas adsorbed/g adsorbent)

3.3.2 X-ray Diffraction (XRD)

X-ray Diffraction (XRD) analysis is generally performed based on the fact that an X-ray diffraction pattern is unique for each crystalline substance. Thus, if an exact match can be found between the pattern of an unknown and an authentic sample, chemical identity can be assumed. It is also possible to make a relatively quantitative analysis by comparing the intensity of the diffraction lines. When comparing the same crystalline substance of two different samples, the higher intensity indicates the higher content.

The X-ray diffraction patterns of the prepared is obtained by using a Rigaku RINT 2000 diffractometer equipped with a Ni filtered CuK α radiation source ($\lambda = 1.542 \text{ \AA}$) of 40 kV and 30 mV. A catalyst sample is first pressed into a hollow of glass holder and held in place by a glass window. After that, it is scanned in the 2θ range from 5 to 90° in the continuous mode with the rate of $5^\circ/\text{min}$. The XRD results consist of peak parameters, including the centroid 2θ , the full line width at half the maximum of intensity (β), d-value, and intensity. The mean crystallite size will be calculated from the XRD data from X-ray line broadening, using the full line width at half maximum of intensity and the 2θ value and plugging them into the Debye-Scherrer equation (Cullity, 1956 and Matar *et al.*, 1989).

$$T = K\lambda / \beta\cos\theta$$

where

- λ = The X-ray wavelength (0.1542 nm for Cu anode source);
- K = The Debye-Scherrer constant which to some degree depends on the shape of the peak (assume equal to 0.9);
- β = The full width at half maximum (FWHM) of the broadened peak;
- θ = The Bragg angle of the reflection (radian); and
- T = The mean crystallite size (nm)

This equation works well for particle sizes of less than 1,000 Å. The broadening of diffraction lines measured at half the maximum intensity (β) is corrected by using Warren's method, which is:

$$\beta^2 = \beta_M^2 - \beta_S^2$$

where

β_M = The breadth of the diffraction line; and

β_S = The breadth of the line from a standard.

3.3.3 Field Emission Scanning Electron Microscope (FE-SEM)

Field emission scanning electron microscope (FE-SEM) operated at 1 to 20 kV equipped with energy dispersive x-ray spectroscope (EDX) is employed to observe the surface structure of a catalyst sample to identify the element proportion over that area and to evaluate approximately the particle size distribution. The catalyst sample placed on the stub is coated by platinum (Pt) prior to being loaded them into the microscope. A beam is passed through a series of lenses to form a magnified image of a sample that is inserted in the area of the objective lens. The image from selected area is viewed through projection onto a view of screen. Because electron beams can be easily scattered by air molecules, the FE-SEM columns must be kept under high vacuum. Additionally, the electromagnetic lenses are used for focusing the electron beam.

3.3.4 Temperature-Programmed Oxidation (TPO)

The TPO technique is used to quantitatively investigate the coke formation on the spent catalyst. The TPO analysis is performed at a continuous flow of O₂/He (ratio 2:1) with a total flow rate of 40 cm³/min. A spent catalyst about 10-12 mg is placed in a quartz tube, and it is secured with packing quartz wool. The sample temperature is linearly increased with a constant rate of 10 °C/min to reach a maximum temperature of 850 °C. The carbon fraction of the sample then reacts with oxygen to produce products, such as water and carbon dioxide. After this reaction, these products in the effluent gas are passed to a methanator containing Ni/Al₂O₃ catalyst to convert carbon dioxide to methane. Consequently, methane is detected

with a flame ionization detector (FID SRI model 110). The area under the curve obtained is used to calculate carbon content in the sample.

3.4 Catalytic Activity Experiments

The experimental study of ethylene epoxidation was investigated in a parallel dielectric barrier discharge (DBD) reactor at ambient temperature and atmospheric pressure. The schematic of experimental setup for ethylene epoxidation reaction using the DBD system is shown in Figure 3.1. The reactor configuration is shown in Figure 3.2. The reactor sizes are 1.5 cm height x 5.5 cm width x 17.5 cm length for inner dimension and 3.9 cm height x 9.5 cm width x 21.5 cm length for outer dimension, and distance between ethylene feed positions is 3.5 cm. Between the two electrodes, there is a dielectric glass plate. The gap distance between the two electrodes is fixed at 7 mm (Suttikul *et al.*, 2011).

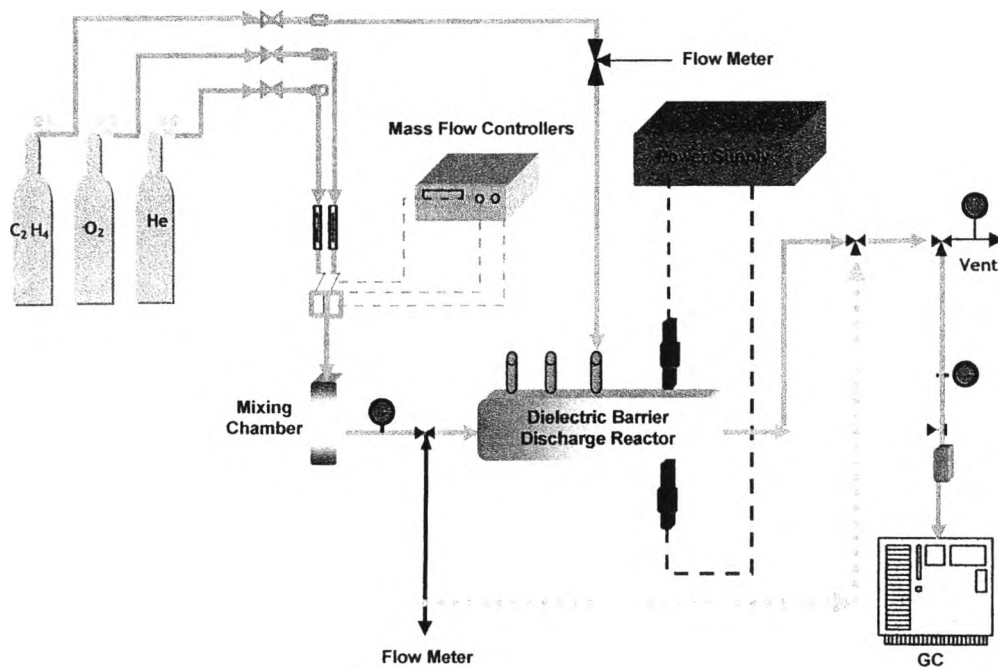

Figure 3.1 Schematics of experimental setup for ethylene epoxidation reaction using parallel DBD.

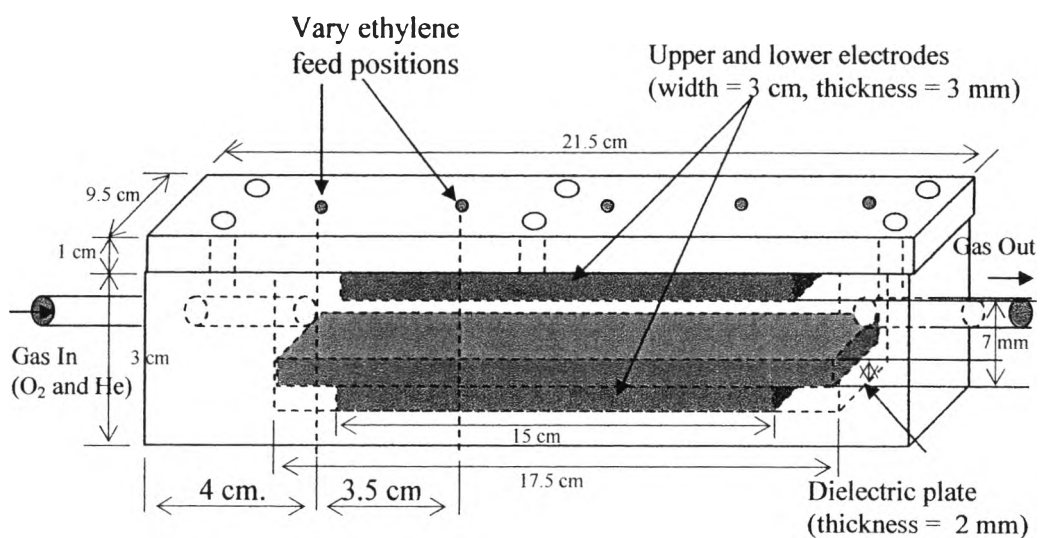

Figure 3.2 The configuration of the Parallel Dielectric Barrier Discharge reactor.

The detailed dimensions of the parallel DBD reactor is given in Table 3.1.

Table 3.1 The detailed dimensions of the parallel DBD reactor

Dimension	Value
Electrode width (cm)	3
Electrode length (cm)	15
Electrode thickness (cm)	0.30
Electrode gap distance (cm)	0.70
Glass thickness (cm)	0.20
Electrode edge length (cm)	71.70
Electrode surface area (cm ²)	89.07
Reaction volume (cm ³)	22.67
Electrode edge length-to-reaction volume ratio (cm ⁻²)	3.22
Electrode surface area-to-reaction volume ratio (cm ⁻¹)	4.00
Distant between each ethylene feed position (cm)	3.5

The reactant gases (ethylene, oxygen, and helium) flowing through the reactor is controlled by a set of electronic mass flow controllers. All reactant lines have 7 μm in-line filters before passing through the mass flow controllers in order to trap any foreign particles. The reactor pressure is controlled via a needle valve. The outlet of reactor is either be vented to the atmosphere via rubber tube exhaust or enter an on-line gas chromatograph (GC) to analyze the product gases. The moisture in the effluent gas is removed by a water trap before entering to the on-line GC. The GC is equipped with both a thermal conductivity detector (TCD) and a flame ionization detector (FID). For the TCD channel, a packed column (Carboxen 1000) is used for separating the product gases, which are hydrogen (H_2), oxygen (O_2), carbon monoxide (CO), carbon dioxide (CO_2), and ethylene (C_2H_4). For FID channel, the capillary column (OV-Plot U) is used for the analysis of ethylene oxide (EO) and other by-product gases, i.e. CH_4 , C_2H_6 , and C_3H_8 . The composition of the product gas stream is determined by the GC every 20 min. When the system reaches steady state, an analysis of the outlet gas compositions is performed at least three

times. The experimental data under steady state conditions is averaged and then used to evaluate the performance of the plasma system. The GC is operated under the following conditions:

TCD injection temperature	120 °C
FID injection temperature	150 °C
Oven temperature	40 °C for 5 min 165°C (heating rate 10 °C/min)
Carrier gas	High purity helium
Carrier gas flow rate	30 cm ³ /min (TCD channel) 25 cm ³ /min (FID channel)
Detector temperature	190 °C in TCD and 280°C for FID

To evaluate the system performance, the C₂H₄ and O₂ conversions and the selectivity for products, including EO, CO, CO₂, H₂, CH₄, C₂H₆, and traces of C₃, is considered. The conversion of either C₂H₄ and O₂ is calculated from the following equation:

$$\% \text{ Reactant conversion} = \frac{(\text{moles of reactant in} - \text{moles of reactant out}) \times 100}{(\text{moles of reactant in})}$$

The product selectivity is calculated from the following equation:

$$\% \text{ Product selectivity} = \frac{[(\text{number of carbon or hydrogen atom in product}) (\text{moles of product produced})] \times 100}{[(\text{number of carbon or hydrogen atom in ethylene}) (\text{moles of ethylene converted})]}$$

The ethylene oxide yield is calculated from the following equation:

$$\% \text{ Ethylene oxide yield} = (\% \text{ ethylene conversion}) \times (\% \text{ ethylene oxide selectivity}) / 100$$

To determine the energy efficiency of the plasma system, the specific power consumption is calculated in a unit of Ws per molecule of converted ethylene or per molecule of produced ethylene oxide using the following equation:

$$\text{Specific power consumption} = \frac{P \times 60}{N \times M}$$

where P = Power (W)

N = Avogadro's number = 6.02×10^{23} molecules/mol

M = Rate of converted ethylene molecules in feed or rate of produced ethylene oxide molecules (mol/min).

3.5 Power Supply Unit

The block diagram of the power supply unit is shown in Figure 3.3. For the first step, the AC input of 220 V and 50 Hz is converted to DC of about 70-80 V by a DC power supply converter. For the second step, the DC is supplied through a 500 Watt power amplifier, which is connected to the Instek function generator to generate waveform and to amplify voltage and frequency. The signal of alternating current is a sinusoidal waveform. For the final step, the amplified AC is passed through the input transformer to convert to 230 V AC. Thereafter, the variable output is transmitted to a high voltage current by nominal factor 130 times of low side (input). An Extech® series 380801 power analyzer is used to measure current, frequency, and voltage at the low side of the power supply unit.

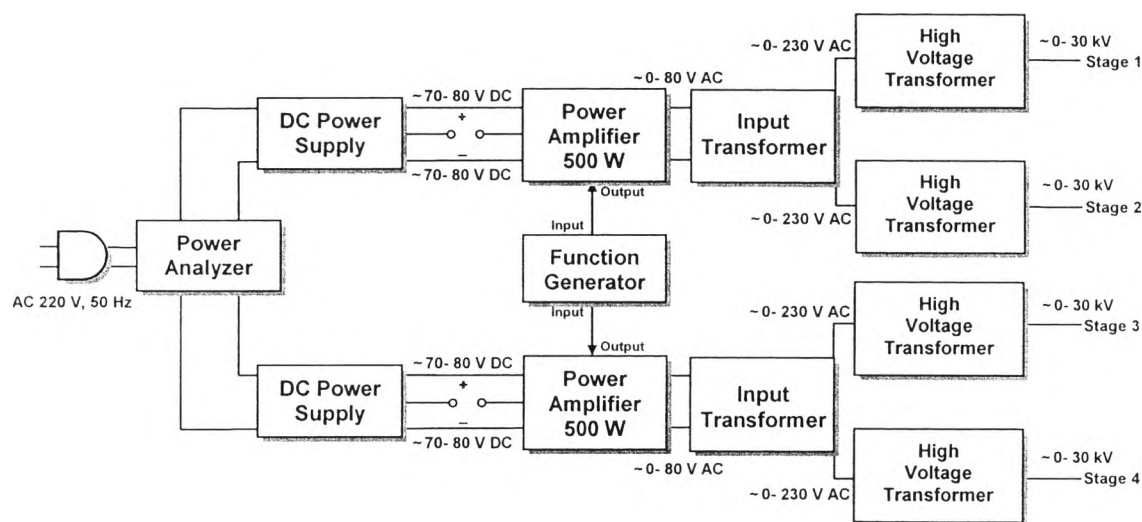

Figure 3.3 Block diagram of the power supply unit.

3.6 Experiment procedures

The main objective of this research is to investigate the combination of catalytic process and the DBD plasma system for improving the efficiency of ethylene epoxidation to form ethylene oxide.

The effect of ethylene feed position is first investigated. The effects of various operating parameters, including the existence of Ag catalyst on SiO₂ supported, O₂/C₂H₄ feed molar ratio, applied voltage, input frequency, and feed flow rate, is further examined.

The experimental conditions as follows:

Ethylene feed position:	5 positions
wt.% of Ag loading:	5%-20%
O ₂ /C ₂ H ₄ molar ratio:	0.2:1-1:1
Applied voltage:	13-19 kV
Input frequency:	400-800 Hz
Feed flow rate:	50-150 cm ³ /min
Electrode gap distance:	7 m