

DETERMINATION OF VOLATILE COMPOUNDS IN YELLOW CURRY PASTE USING FROM-  
TWO-TO-ONE DIMENSIONAL GAS CHROMATOGRAPHY-MASS SPECTROMETRY



A Thesis Submitted in Partial Fulfillment of the Requirements  
for the Degree of Master of Science in Chemistry

Department of Chemistry

FACULTY OF SCIENCE

Chulalongkorn University

Academic Year 2021

Copyright of Chulalongkorn University

การตรวจวัดสารระเหยง่ายในพริกแกงเหลืองโดยใช้แก๊สโครมาโทกราฟี-แมสสเปกโตรเมตรีจากสอง  
มิติไปหนึ่งมิติ



วิทยานิพนธ์นี้เป็นส่วนหนึ่งของการศึกษาตามหลักสูตรปริญญาวิทยาศาสตรมหาบัณฑิต  
สาขาวิชาเคมี ภาควิชาเคมี  
คณะวิทยาศาสตร์ จุฬาลงกรณ์มหาวิทยาลัย  
ปีการศึกษา 2564  
ลิขสิทธิ์ของจุฬาลงกรณ์มหาวิทยาลัย

Thesis Title	DETERMINATION OF VOLATILE COMPOUNDS IN YELLOW CURRY PASTE USING FROM-TWO-TO-ONE DIMENSIONAL GAS CHROMATOGRAPHY-MASS SPECTROMETRY
By	Miss Natsuda Singtothog
Field of Study	Chemistry
Thesis Advisor	Associate Professor THUMNOON NHUJAK, Ph.D.
Thesis Co Advisor	Assistant Professor Chadin Kulsing, Ph.D.

---

Accepted by the FACULTY OF SCIENCE, Chulalongkorn University in Partial Fulfillment of the Requirement for the Master of Science

..... Dean of the FACULTY OF SCIENCE  
(Professor POLKIT SANGVANICH, Ph.D.)

THESIS COMMITTEE

..... Chairman  
(Professor VUDHICHAJ PARASUK, Ph.D.)

..... Thesis Advisor  
(Associate Professor THUMNOON NHUJAK, Ph.D.)

..... Thesis Co-Advisor  
(Assistant Professor Chadin Kulsing, Ph.D.)

..... Examiner  
(Assistant Professor Puttaruksa Varanusupakul, Ph.D.)

..... External Examiner  
(Assistant Professor Natthida Sriboonvorakul, Ph.D.)

ณัฐสุดา สิงห์โตทอง : การตรวจวัดสารระเหยง่ายในพริกแกงเหลืองโดยใช้แก๊สโครมาโทกราฟี-แมสสเปกโตรเมตรีจากสองมิติไปหนึ่งมิติ. ( DETERMINATION OF VOLATILE COMPOUNDS IN YELLOW CURRY PASTE USING FROM-TWO-TO-ONE DIMENSIONAL GAS CHROMATOGRAPHY-MASS SPECTROMETRY) อ.ที่ปรึกษาหลัก : รศ. ดร.ธรรมบุญ หนูจักร, อ.ที่ปรึกษาร่วม : ผศ. ดร.ชฎิล กุลสิงห์

ในงานวิจัยนี้ ได้พัฒนาวิธีการวิเคราะห์ด้วยแก๊สโครมาโทกราฟี-แมสสเปกโตรเมตรีแบบหนึ่งมิติ (1D GC-MS) สำหรับการวิเคราะห์เครื่องแกงเหลือง วิธีการนี้เกี่ยวข้องกับการประยุกต์ที่ตั้งต้นจากการวิเคราะห์ด้วยแก๊สโครมาโทกราฟี-แมสสเปกโตรเมตรีแบบสองมิติชนิด comprehensive heart-cut (CH/C 2D GC-MS) ที่ได้รูปแบบสารระเหยง่ายทั้งหมดโดยเปรียบเทียบแมสสเปกตรัมและรีเทนชันอินเดกซ์ของสารที่ได้จากการทดลองกับค่าอ้างอิงที่ได้จากฐานข้อมูล จากนั้นใช้รูปแบบสารระเหยง่ายที่ได้เพื่อเป็นข้อมูลสำหรับวิธี selected ion monitoring (SIM) ซึ่งต่อมาประยุกต์กับ 1D GC-MS ที่ใช้ SIM ได้นำวิธีการนี้สำหรับปรับปรุงการวิเคราะห์ตัวอย่างเครื่องแกงเหลือง ค่า peak capacity ที่ได้เป็น 1207 สำหรับ 1D GC-MS และ 2080 สำหรับ CH/C 2D GC-MS อย่างไรก็ตามค่า peak capacity จาก 1D GC-MS ที่น้อยกว่าก็เพียงพอสำหรับการวิเคราะห์ตัวอย่างเครื่องแกงเหลือง แต่การวิเคราะห์ด้วย 1D GC-MS ที่ใช้ SIM ในการวิเคราะห์ซึ่งมีความซับซ้อนน้อยกว่าใช้เวลาในการวิเคราะห์และการทำซ้ำที่ต่ำกว่า วิธีการพัฒนาขึ้นนี้ให้ประสิทธิภาพและง่ายสำหรับการวิเคราะห์ตัวอย่างที่ซับซ้อนได้

จุฬาลงกรณ์มหาวิทยาลัย  
CHULALONGKORN UNIVERSITY

สาขาวิชา เคมี  
ปีการศึกษา 2564

ลายมือชื่อนิสิต .....  
ลายมือชื่อ อ.ที่ปรึกษาหลัก .....  
ลายมือชื่อ อ.ที่ปรึกษาร่วม .....

# # 6171954123 : MAJOR CHEMISTRY

KEYWORD: 2D separation, GC-MS, method translation, Thai food, volatile compounds

Natsuda Singtothog : DETERMINATION OF VOLATILE COMPOUNDS IN YELLOW CURRY PASTE USING FROM-TWO-TO-ONE DIMENSIONAL GAS CHROMATOGRAPHY-MASS SPECTROMETRY. Advisor: Assoc. Prof. THUMNOON NHUJAK, Ph.D. Co-advisor: Asst. Prof. Chadin Kulsing, Ph.D.

In this work, an approach to allow improved analysis with one-dimensional GC-MS (1D GC-MS) was established and demonstrated for analysis of a pool of yellow curry paste samples. The approach involved initial application of comprehensive heart cut two-dimensional GC-MS (CH/C 2D GC-MS) to obtain a full volatile profile by comparing the experimental mass spectrum and retention index of each compound with the mass spectra and retention indices of standard compounds from a database. The obtained volatile profile was then used to generate a selected ion monitoring (SIM) method, which was then applied with 1D GC-MS using a SIM mode. This approach was further applied for improved analysis of several yellow curry paste samples. The peak capacity was approximated as 1207 for 1D GC-MS with a SIM mode, and 2080 for CH/C 2D GC-MS. However, the lower peak capacity from 1D GC-MS was sufficient for analysis of yellow curry paste samples. The analysis times and repeatability could also be expected to be better with less complicated experimental setup of the 1D GC-MS with a SIM mode analysis. The established approach provided a simple and effective approach for the analysis of complex samples in the future.

Field of Study: Chemistry

Academic Year: 2021

Student's Signature .....

Advisor's Signature .....

Co-advisor's Signature .....

## ACKNOWLEDGEMENTS

First of all, I would like to thank my thesis advisor, Associate Professor Dr. Thumnoon Nhuajak, and co-advisor Assistant Professor Dr. Chadin Kulsing for help, support, knowledge, and advice throughout the thesis.

I would like to thank all thesis examiners, Professor Dr. Vudhichai Parasuk, Assistant Professor Dr. Puttaruksa Varanusupakul, Assistant Professor Dr. Natthida Sriboonvarakul for useful suggestions and comments

I would like to thank members of Chromatography and Favor Chemistry Research Group and ChromatoKikTaNie Lab for help, support, knowledge, and friendship.

I would like to thank Department of Chemistry, Faculty of science, Chulalongkorn University for support instruments and facilities in this thesis.

Finally, I would like to thank my parents and family, who support, encouragement, and behind the successful of my education and works.

Natsuda Singtothog

## TABLE OF CONTENTS

	Page
ABSTRACT (THAI) .....	iii
ABSTRACT (ENGLISH) .....	iv
ACKNOWLEDGEMENTS .....	v
TABLE OF CONTENTS .....	vi
LIST OF TABLES .....	viii
LIST OF FIGURES .....	ix
CHAPTER I .....	1
INTRODUCTION .....	1
1.1 Problem definition .....	1
1.2 Literature review .....	2
1.3 Aim, Scope and expected benefits of this work .....	3
CHAPTER II .....	4
THEORY .....	4
2.1 Gas chromatography (GC-MS) .....	4
2.2 Gas chromatography-mass spectrometry (GC-MS) .....	5
2.3 Multidimensional gas chromatography (MDGC) .....	6
2.4 Mass spectrometry .....	7
2.4.1 Ion source (Electron ionization, EI) .....	7
2.4.2 Mass analyzer .....	8
2.4.3 Ion detector .....	9
CHAPTER III .....	10

EXPERIMENTAL .....	10
3.1 Instruments, equipment and apparatus.....	10
3.2 Chemicals and Samples.....	10
3.3 Analysis of volatile compounds.....	11
3.3.1 CH/C 2D GC-MS .....	11
3.3.2 1D GC-MS with a SIM mode.....	11
3.4 Data processing.....	11
CHAPTER IV .....	14
RESULTS AND DISCUSSION.....	14
4.1 CH/C 2D GC-MS analysis of a pool of yellow curry samples.....	14
4.2 1D GC-MS with a SIM mode analysis of yellow curry samples.....	21
CHAPTER V .....	29
CONCLUSION .....	29
REFERENCES .....	31
VITA.....	36



## LIST OF TABLES

	Page
Table 1 Volatile compound profiles with odor description, literature retention index on <sup>1</sup> D nonpolar column and the compound peak areas in the pool of yellow curry paste samples analysed by CH/C 2DGC. ....	16
Table 2 Volatile compound profiles of different yellow curry paste samples analyzed by 1D GC-MS with a SIM mode detecting four characteristic m/z values for each compound.....	22



## LIST OF FIGURES

	Page
Figure 1 GC diagram. Reproduced from [23].	5
Figure 2 GC-MS instrument. Reproduced from [14].	6
Figure 3 MDGC instrumentation. Reproduced from [28].	7
Figure 4 Diagram showing the components of mass spectrometry. Reproduced from [17].	8
Figure 5 Quadrupole mass analyzer. Reproduced from [30].	9
Figure 6 CH/C MDGC result (1 <sup>st</sup> , 2 <sup>nd</sup> and 3 <sup>rd</sup> injections) using H/C window of 0.2 min of the pool of yellow curry paste sample.	15
Figure 7 Correlation between x-axis: <sup>1</sup> D retention time values obtained from CH/C 2D GC analysis of a volatile compounds in the pool sample and y-axis: retention time values obtained from 1D GC-MS with a SIM mode analysis of the same compounds in the yellow curry paste sample 1-3 (□, X and Δ, respectively).	27
Figure 8 GC-SIM MS results of a yellow curry paste sample using different m/z values of 73 58 55 31, A-D respectively.	28

## CHAPTER I

### INTRODUCTION

#### 1.1 Problem definition

In general, food consists of many chemical groups, for example, amino acids, organic acid, protein, aroma compounds and nutrients food contains proteins, carbohydrates, fats, vitamins, and fibers. These compounds have a mass range, polarity and a large number of molecules. Profile of curry paste has been identified and quantified as complex food with the requirement for development of analytical methods for improved food analysis. The ingredient of curry paste includes chili, garlic, shallot, and curcumin [1-3], which has difference volatile compound profile such as Beta-caryophyllene, Allicin, Diallyl disulfide, and Curcuminoid. The characteristics of food aroma are very complex matrix mostly consisting of volatile and semi-volatile compounds [3]. Normally, the conventional analysis method is gas chromatography-mass spectrometry (GC-MS). The GC-MS can separate volatile compounds in food or herbs in the curry paste because GC-MS has a high separation performance using one column separated by boiling point, volatile and semi-volatile compounds. The commonly applied detector is mass spectrometry (MS) which can predict types of compounds by comparing characteristic mass and specific fragmentation pattern from the National Institute of Standards and Technology (NIST) 2017. Application of GC-MS includes environmental analysis, identification of unknown samples, foodstuff, and trace elements in materials.

The advanced analytical technique involves comprehensive heart-cut multidimensional gas chromatography (CH/C MDGC) of thousands of compounds in food in a single analysis. This technique is simple for separation of analytes from a large number of sample matrix components. CH/C MDGC has high sensitivity, selective mass spectrometry and reduced interference background.

However, the expense of analysis cost and time for additional chromatographic separation is often required for improved analysis of various compounds. Thus, in this study, we developed the technique of GC-MS to enable to separate compounds with the capability comparable to two-dimensional gas chromatography-mass spectrometry (2D GC-MS) in order to avoid a complicate system and difficulty in repeated analysis.

## 1.2 Literature review

The major ingredients of yellow curry paste include garlic, shallot, pepper, and curcumin, which have different volatile components. Positive properties of garlic include anti-bacterial, anti-oxidant, anti-microbial, and anti-asthmatic agents [4]. Volatile compound profiles of fresh and black garlic samples contained 51 volatile compounds tested by using HS-GC-MS analysis. The main components were thiosulfinates and sulfur volatiles, as well as the characteristic aroma compounds of garlic including diallyl sulfide, dimethyl trisulfide, diallyl disulfide, diallyl trisulfide, and 2-butenal. Besides, the composition of garlic included amino acids with the major components of glutamic acid (Glu 29%), aspartic acid (Asp 17%), serine (Ser 11%), and so on [5, 6].

GC-MS is an analytical technique used to separate and identify volatile or semi volatile compounds. Applications of GC-MS range from food analysis to the areas of environmental, drug, essential oil, biological, petroleum, forensic, pharmaceutical, and perfume. When combined with MS, MS enables fragmentation of components and their identification is based on the mass to charge ratios, e.g. by using the NIST library program [7-10].

MS provides a powerful detector for GC, which is sensitive, selective, and offers superior qualitative analysis. In general, MS can operate in full scan and selected ion monitoring (SIM) mode, a full scan is set with a wide mass scan range such as 35-500 Da and results in data of total ion chromatogram (TIC). SIM mode selects only specific  $m/z$  values of ions. SIM mode improves selectivity and resolution and reduces interferences [11-14]. Applications of GC-MS with SIM mode include food flavoring compounds, organic compounds, biological and environment [15-18].

MDGC is a technique using two different capillary columns. This technique provides confidence in compound identification, improved resolution, enhanced peak capacity, reliable analysis of a complex sample, and low detection limit. However, MDGC with high separation efficiency requires a long analysis time and complicated setup system [7, 19-21].

### **1.3 Aim, Scope and expected benefits of this work**

The aim of this work is to improve analysis of volatile and semivolatile compounds in yellow curry using 1D GC—MS with a SIM mode. First, CH/C 2D GC-MS was established for the analysis of yellow curry paste samples. Then, the selected m/z values of the separated compounds were further applied in a SIM mode in 1D GC-MS. This is performed based on the information obtained from CH/C 2D GC-MS providing total volatile profile which was used to generate 1D GC-MS with a SIM mode. This technique provided identification performance, capability of mass spectrometry for identified compounds in a SIM mode compared with 1D GC-MS full scan. The benefit of this work is to improve and expect repeatability compared with CH/C 2D GC-MS reduces injections of 2D GC-MS and analysis time.

## CHAPTER II

### THEORY

#### 2.1 Gas chromatography (GC-MS)

Gas chromatography (GC) is an analytical technique used for vaporizing and separating compounds without decomposition. Figure 1 shows an example of a GC diagram. When a sample solution is injected into the GC system, the compounds in the samples are heated and vaporized within one injection. GC system consists of carrier gas e.g. nitrogen, helium, or hydrogen gas, which passes the sample components passing through the column (stationary phase). The GC column contains a liquid or solid phase material as stationary phase. The sample components should have different boiling points or interactions (e.g. polar and/or nonpolar) with the stationary phase, such as the more polar eluting later on a polar column. The detector is placed at the column outlet, which responds the signals of the sample and shows a chromatogram (a plot between signal vs retention time) containing peaks of volatile compounds in the sample. The signal intensity will be proportional to the amount of each analyte that elutes from the column with the overall process.

There are various types of detectors used in GC have such as mass spectrometry (MS), nitrogen-phosphorous detector (NPD), electron capture detector (ECD), flame ionization detector (FID), mass selective detector (MSD) operated in full scan mode, and atomic emission detector (AED). All detectors provide high sensitivity, efficiency, fast response, low detection limit and linearity range [22].

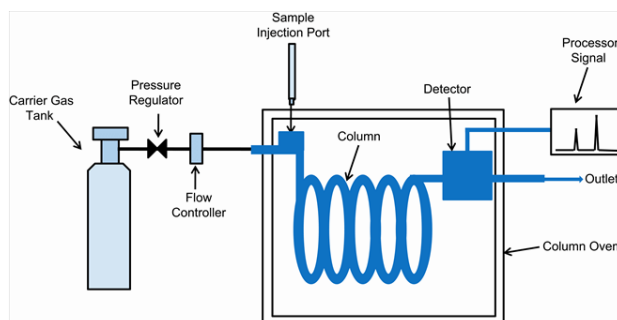

Figure 1 GC diagram. Reproduced from [23].

## 2.2 Gas chromatography-mass spectrometry (GC-MS)

Gas chromatography-mass spectrometry (GC-MS) is a hyphenated technique used in analytical chemistry, combining the benefits of two different analytical techniques. GC provides separation of volatile organic compounds in a complex sample, and MS is for detection, identification and/or quantification. This technique offers high specificity and sensitivity which is very useful in the field of untargeted analysis. in many branches such as analyses of food, medical, environmental, biological and others.

Compounds in a sample mixture analyzed and identified by GC-MS must be volatile and thermally stable which are detected as peaks in a chromatogram. After the compounds vaporization pass through the column by inert carrier gas and are separated inside the column, and/or polar and nonpolar. Each compound is expected to have different retention time as shown in Figure 2.

performance of the GC method can be adjusted by changing experimental conditions such as temperature program, flow rate, type of column, film thickness, diameter and length of column, and type of stationary phase.

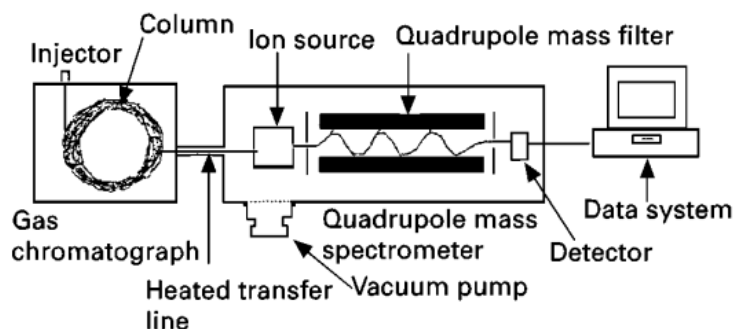

Figure 2 GC-MS instrument. Reproduced from [14].

### 2.3 Multidimensional gas chromatography (MDGC)

Multidimensional gas chromatography (MDGC), as shown in Figure 3, refers to two different GC columns assigned as first dimensional ( $^1D$ ) and second dimensional ( $^2D$ ) columns with different selectivities such as  $^1D$  non-polar/ $^2D$  polar or  $^1D$  polar/ $^2D$  non-polar. The  $^1D$  and  $^2D$  columns with different lengths are connected via an interface called a modulator. MDGC can be divided into two types which are comprehensive two-dimensional GC (GCXGC) and comprehensive heart cut MDGC (CH/C MDGC). The GCXGC technique is performed using a single injection to complete a whole sample analysis using a short  $^2D$  column. On the other hand, the CH/C MDGC technique is performed using multiple injections with a longer  $^2D$  column of about 30 to 60 m. In CH/C analysis, Dean switch (DS) [24, 25] is used as the interface, which allows analyte to transfer from  $^1D$  column and controls analyte to release onto  $^2D$  column or a restrictor column used to balance flows between both columns. A cryogenic trapping device can be applied with either or GCXGC or CH/C MDGC using a cryogen such as cryogenic liquid nitrogen, which focuses, traps and releases analytes into  $^2D$  column increasing prior to the detection [26-29].



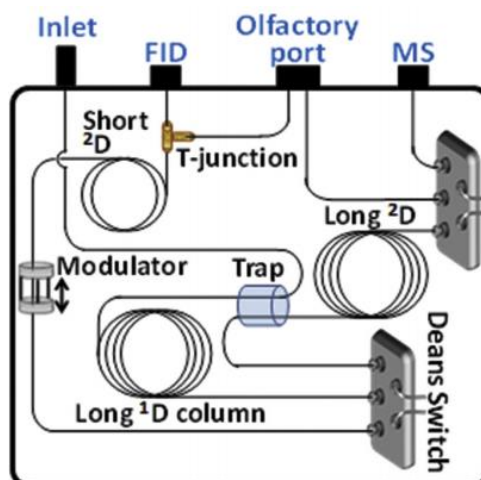

Figure 3 MDGC instrumentation. Reproduced from [28].

## 2.4 Mass spectrometry

Mass spectrometry (MS) is a technique used to identify unknown compounds in samples. This technique is highly sensitivity which can separate and detect ions in the gas phase. MS is based on fragmentation and ionization of sample molecules in the gas phase. Molecules can undergo ionization becoming odd-electron ion,  $[M+\bullet]$  or even-electron ion  $[M+]$ , and can be detected by the detector. In addition, fragmented ions are observed depending on the characteristic of compounds. In general, MS has instrumental components consisting of ion source, mass analyzer, detector, and data system under vacuum system as shown Figure 4. Ions within a sample are produced in the ion source. Then, mass analyzer separates ions according to their mass-to-charge ( $m/z$ ) ratios. Detector detects and records the ion intensities as well as data system recording and the signal amplifying.

### 2.4.1 Ion source (Electron ionization, EI)

After separation in GC, the separated components from the column are transferred into an ion source of MS via a heated transfer line where they are converted to ions. Electron Ionization (EI) is the most common ionization technique used for GC-MS. An EI source consists of a heat filament that produces electron accelerated towards an anode. Analyte molecules produce molecular ions ( $M+\bullet$ ) with high amount of internal energy. Since the ionization is produced by a single electron

that is accelerated to 70 V (corresponding to the energy of -70 eV), this is enough energy to cause extensive fragmentation which is useful for untargeted compound identification by comparison with MS spectrum data from the libraries. The positive charges attract and accelerating direct to the mass analyzer.

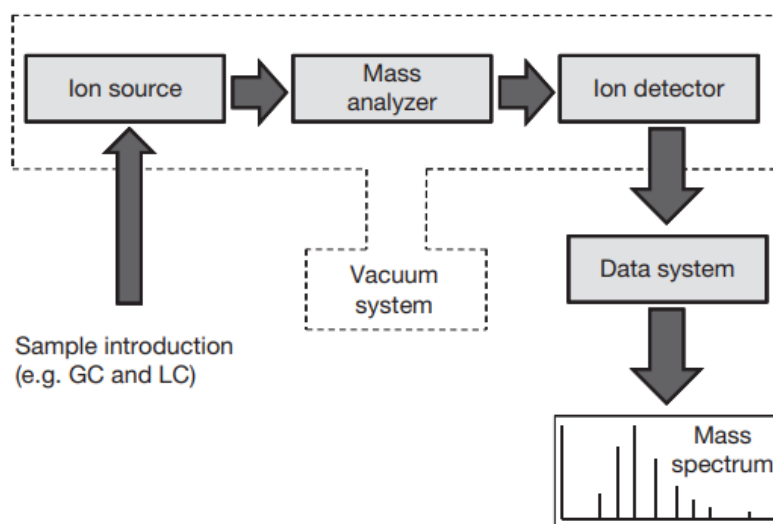

Figure 4 Diagram showing the components of mass spectrometry. Reproduced from [17].

#### 2.4.2 Mass analyzer

From the ion source, the fragment ions are differently accelerated into the mass analyzer according to their  $m/z$  values. The several types of mass analyzers including magnetic sector, time-of-flight, quadrupole, ion trap, and tandem have been developed. The selection of a mass analyzer depends on a mass range, resolution, scan rate, a linearity range, or detection limit. Quadrupole mass spectrometer (QMS) is the most common mass analyzer in GC-MS. As shown in Figure 5 [30], a typical quadrupole mass analyzer consists of four rods with a hyperbolic cross section with a pair of positive and negative rods with the application of fixed Direct Current (DC) and alternating Radio Frequency (RF) potentials. Ions produced in the source of the instrument then travel through the Q, and they are filtered according to their  $m/z$  value so that only ions with a single  $m/z$  value survive from the Q and strike the detector. The RF is varied to bring ions of different  $m/z$  into

focus at the Q center and allow them to reach the detector resulting in a mass spectrum. Most quadrupole instruments are limited to unit  $m/z$  resolution and have a mass range up to  $m/z$  of 1000. The most selective mode with a single quadrupole MS is called selected ion monitoring (SIM) where a fixed set of DC and RF voltages is applied to the quadrupole allowing only ions with a single  $m/z$  to pass through. Ions with different  $m/z$  are filtered out.

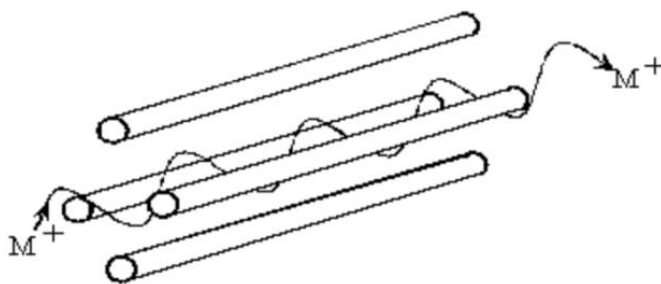

Figure 5 Quadrupole mass analyzer. Reproduced from [30].

### 2.4.3 Ion detector

Ions passing through the mass analyzer are accelerated and detected when they are collided with the multiplier surface emitting electrons. Their signals are transformed by the detector based on their charge or momentum. A detector can generate electric current proportional to ion abundance. The performance of a detector depends on geometry, gain, velocity, dynamic range, and sensitivity. The most commonly used ion detector in GC-MS is the electron multiplier (EM) due to its signal amplification ability and being cost effective.

## CHAPTER III

### EXPERIMENTAL

#### 3.1 Instruments, equipment and apparatus

A CH/C 2D GC-MS system was performed using GC—QqQMS system (7890A-7000, Agilent technologies Inc.), while Gerstel MPS 7890B-5977B MSD was used for a 1D GC-MS system (Agilent technologies Inc.). Both systems consist of autosampler and column oven couple with a mass spectrometry operated by electron impact ionization (EI), triple quadrupoles, and MassHunter software processing.

In CH/C 2D GC-MS with a restrictor column (1.5 m x 0.1 mm; Agilent technologies Inc, USA), an HP-5MS capillary column (30 m x 0.25 mm i.d., 0.25  $\mu\text{m}$  film thickness; J&W Scientific, USA), and a DB-WAX capillary column (60 m x 0.25 mm x 0.25  $\mu\text{m}$ ; J&W Scientific, USA) were used as the <sup>1</sup>D and <sup>2</sup>D columns, respectively. For 1D GC-MS, the HP-5MS capillary column (30 m x 0.25 mm i.d., 0.25  $\mu\text{m}$  film thickness; Agilent technologies Inc.) was used

The following equipment and apparatus were used: GC glass vial of 2 mL (Agilent technologies USA), syringe of 10  $\mu\text{L}$ , (Agilent technologies USA), Micropipettes 100-1000  $\mu\text{L}$ , (Eppendorf (Germany)), PTFE 0.20  $\mu\text{M}$ , (National scientific, U.K), Vortex mixer (Scientific Industries, USA), A 4 digits-Balance (Mettler Toledo, USA), and Dean switch (Agilent technologies USA).

#### 3.2 Chemicals and Samples

The mixture of *n*-alkanes C8-C20 CAS: 110-54-3 (Sigma Aldrich, Bellefonte, PA) was used as a reference to calculate retention index (I) of the chemical compounds. *n*-Hexane was purchase from RCL Labscan Limited CO., Ltd. USA. Three samples of yellow curry paste were purchased from Thai supermarket.

For sample preparation, 1 g of yellow curry paste sample was weighted and dissolved in hexane with 2 mL for CH/C 2D GC-MS and 1 mL for 1D GC-MS. Then the hexane extract was filtered by a 0.20  $\mu\text{m}$ -PTFE syringe filter prior to GC-MS analysis.

### 3.3 Analysis of volatile compounds

#### 3.3.1 CH/C 2D GC-MS

With a splitless mode, injection port temperature of 240 °C and injection volume of 1  $\mu\text{L}$  were set with helium (99.999%) flow rate of 2.0 and 4.0 mL/min. FID and MS temperatures were set at 300 °C and 240 °C respectively. The GC temperature program for <sup>1</sup>D nonpolar HP-5MS column was set at 40 °C held for 6 min<sup>-1</sup> and then increased to 250 °C at a rate of 6 °C/min. The restrictor column was applied to balance flow with <sup>2</sup>D column, then the outlets of restrictor column and <sup>2</sup>D column connected to FID and MS, respectively. DS was operated in ON/OFF (ON into FID and OFF into MS) set time between OFF about 5 min and 0.2 min for ON and then transfer to <sup>1</sup>D column connected to FID, and MS, respectively. The mass spectrometry operated by electron impact -70 eV and the mass range of 28-550 m/z was applied. The temperature was set at 250 °C.

#### 3.3.2 1D GC-MS with a SIM mode

With a splitless mode, injection port temperature of 240 °C and injection volume of 0.5  $\mu\text{L}$  were set with helium (99.999%) flow rate of 1.8 mL/min. MS temperature was set at 240 °C. The initial temperature of a HP-5MS capillary column began at 40 °C held for 5 min and increased to 200 °C at a rate of 5 °C/min then raised to 240 °C at a rate of 10 °C/min held for 5 min. The mass spectrometry operated by electron impact -70 eV. Selected ion monitoring set Dwell time 50 ms. The temperature of quadrupole and ion source in MS was set at 150 °C and 230 °C respectively. The m/z values and compounds were as shown in Table 2.

### 3.4 Data processing

Data presentation and identification of volatile compounds in GC-MS were performed using Agilent MassHunter software. A peak of interest was identified by

the comparison of the MS spectrum with that from the NIST17 library. The identification criteria were a match score >650 and difference of  $\pm 20$  units between experimental retention index (RI) and the literature values on the semi nonpolar column. The experimental RI was obtained by comparison of a peak retention time with that of the alkanes eluting just before and after this peak under the same separation conditions. The results were further processed using Microsoft Excel.

For calculation of  $^1I$  in CH/C 2DGC, *n*-alkane standards were injected under the same experimental conditions as that applied for the Yellow Curry paste samples with DS off. Van den Dool and Kratz equation was used to calculate  $I$  for a peak according to [31]

$$^1I = 100n + 100 \left( \frac{^1t_{R(i)} - ^1t_{R(n)}}{^1t_{R(n+1)} - ^1t_{R(n)}} \right) \quad (1).$$

$^1t_{R(i)}$  is retention time of the peak on the  $^1D$  column.  $n$  and  $n+1$  are the numbers of carbons of alkanes with the elution times bracketing  $^1t_{R(i)}$ . In this study,  $^1t_R$  is calculated from  $t_{H/Cmid}$  as

$$^1t_R = t_{H/Cmid} = \frac{t_{H/Cstart} + t_{H/Cend}}{2} \quad (2).$$

$t_{H/Cmid}$ ,  $t_{H/Cstart}$  and  $t_{H/Cend}$  are H/C center time, start time and end time of the H/C, respectively. Note that calculation of  $I$  in 1DGC-SIM MS was also performed using Equation 1 albeit with  $t_R$  was applied instead of  $^1t_R$ .  $^2t_R$  in CH/C 2DGC can be calculated as

$$^2t_R = t_{observed} - ^1t_R \quad (3).$$

$t_{observed}$  is the peak time observed with MS after elution through  $^1D$  and  $^2D$  columns. In the case of a peak of compound split into different H/C fractions,

calculation of  $^1t_R$  and  $^2t_R$  of a compound was based on weight average of each sub-peak area.



## CHAPTER IV

### RESULTS AND DISCUSSION

#### 4.1 CH/C 2D GC-MS analysis of a pool of yellow curry samples

The analysis of volatile compounds in yellow curry used a development 1D GC-MS operated with SIM mode as a simple approach providing similar result to that of CH/C-2DGC. Initial CH/C-MDGC result was obtained from a pool of samples contain all the expected compounds in yellow curry.

The sample pool was analyzed using cryogenic free CH/C MDGC approach. With this approach, all the peaks obtained from <sup>1</sup>D separation were H/C with the constant window of 0.2 min prior to <sup>2</sup>D separation. Cyclic multiple H/C strategy and multiple injections were applied <sup>1</sup>D with <sup>2</sup>D separation time of 5 min. This applied 25 injections with the total analysis time of 25 h. The example result is shown in Figure 6 with all the identified compounds profile and odor description shown in Table 1. In general, the sample pool contained 119 volatile compounds identified based on <sup>1</sup>/<sub>1</sub> and MS library match. Their peak area percentages were obtained based on the total peak areas (combining all the sub-peaks of the same compound caused by the CH/C process) in MS full scan mode. The major components based on the peak area percentages were 2,2,3,4-tetramethyl pentane (18 %),  $\alpha,\alpha$ -dimethyl-benzene methanol (6 %) and 2-ethyl-6-methylphenol (8 %) which contributed to the smells of not available, green, sweet and not available, respectively. Other compounds with their odor descriptors were provided in Table 1.



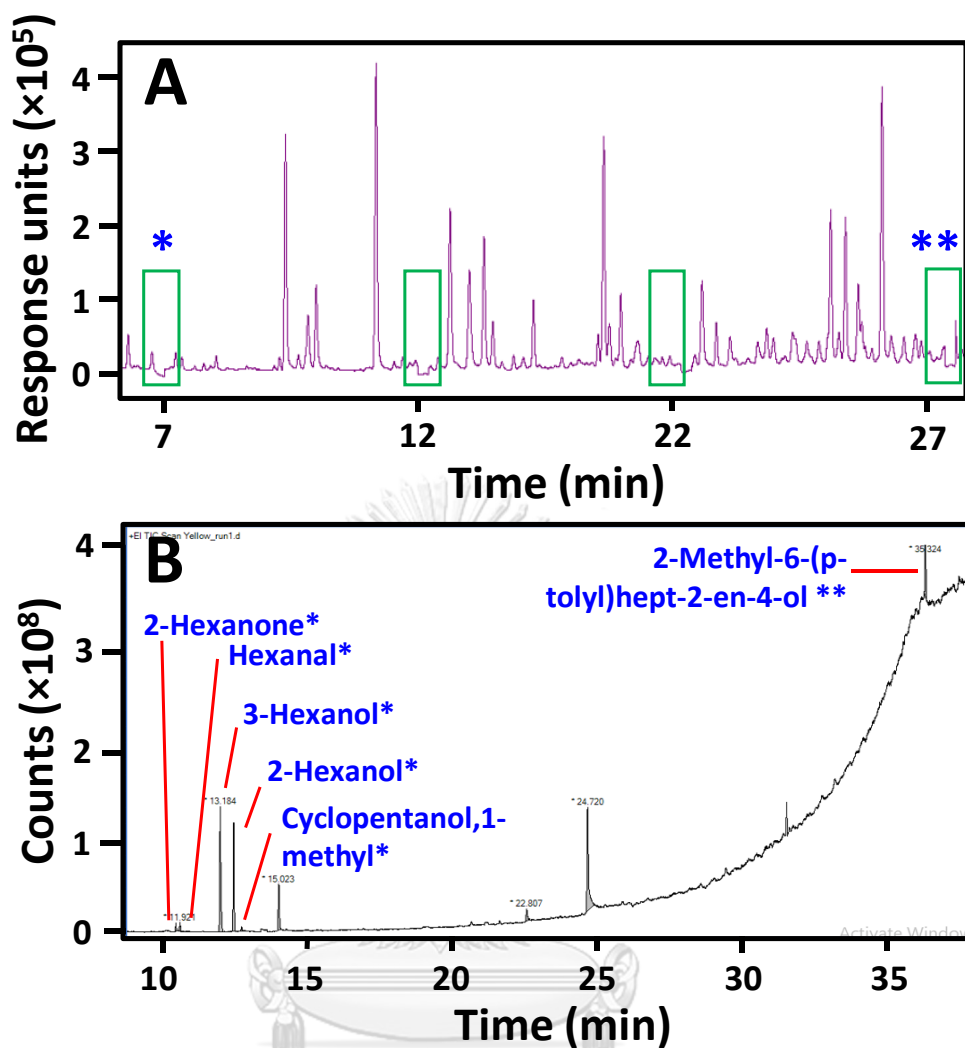

Figure 6 CH/C MDGC result (1<sup>st</sup>, 2<sup>nd</sup> and 3<sup>rd</sup> injections) using H/C window of 0.2 min of the pool of yellow curry paste sample.

Table 1 Volatile compound profiles with odor description, literature retention index on <sup>1</sup>D nonpolar column and the compound peak areas in the pool of yellow curry paste samples analysed by CH/C 2DGC.

Identified compound name	Odor description	CAS No.	/ lit	CH/C 2DGC analysis of the sample pool		
				Peak area (×10 <sup>4</sup> )	<sup>1</sup> t <sub>R</sub> (min)	<sup>2</sup> t <sub>R</sub> (min)
2-hexanone	Fresh green odor	591-78-6	790	451	7.10	4.7
hexanal	Aldehydic fatty oily-green fruity	66-25-1	800	512	7.10	4.8
1-methyl-cyclopentanol	NA	1462-03-9	797	248	7.10	6.8
3-hexanol	Fresh green odor spicy fruity fatty	623-37-0	797	10743	7.12	6.1
2-hexanol	Fresh green odor spicy fruity fatty	626-93-7	801	12752	7.18	6.4
2-hydroxyethyl propanoate	Sweet fruity pineapple-like ethereal-buttery	97-64-3	815	780	7.50	13.5
2,2,3,4-tetramethylpentane	NA	1186-53-4	821	401588	7.55	2.3
3-ethyl-2,2-dimethylpentane	NA	16747-32-3	824	33838	7.90	2.3
2-methyl-2-pentenal	Fruity aldehydic juicy green	623-36-9	837	2998	7.90	5.6
lactic acid	NA	50-21-5	838	684	7.90	13.1
3,4-dimethylheptane	NA	922-28-1	858	35184	8.10	2.3
2,4-dimethyl-1-heptene	NA	19549-87-2	836	355	8.10	3.0
3-methylbutanoic acid	Fruity acidic pungent cheesy sour	503-74-2	863	3307	8.10	14.8
2-methylbutanoic acid	Acidic fruity dirty cheesy	116-53-0	861	3381	8.30	14.6
diallyl sulfide	Pungent sulfurous onion garlic	592-88-1	861	2316	8.50	5.2
2,2,4-trimethylheptane	NA	14720-74-2	876	97371	8.50	2.4
2,2,4-trimethylheptane	NA	14720-74-2	876	97371	8.50	2.4
<i>o</i> -xylene	Geranium	95-47-6	887	2661	8.90	4.9
3-methyl-2-hexanol	NA	2313-65-7	909	674	9.30	11.7
2-heptanol	Citrus fruity floral green herbal sweet fresh lemongrass	543-49-7	900	559	9.50	11.5
allyl methyl disulfide	Alliaceous, garlic green onion	2179-58-0	920	4496	10.00	6.4
2,2-dimethyloctane	NA	15869-87-1	916	31156	10.10	2.3
2,2-dimethyloctane	NA	15869-87-1	916	31156	10.10	2.3
allylbenzene	NA	300-57-2	934	13233	10.27	4.4
2,2,6-trimethyloctane	NA	62016-28-8	963	64467	10.50	2.5
( <i>Z</i> )-1-methyl-2-(prop-1-en-1-yl) disulfane	NA	23838-18-8	932	240	10.50	6.4

Identified compound name	Odor description	CAS No.	/ lit	CH/C 2DGC analysis of the sample pool		
				Peak area ( $\times 10^4$ )	$^1t_R$ (min)	$^2t_R$ (min)
( <i>E</i> )-1-methyl-2-(prop-1-en-1-yl) disulfane	NA	23838-19-9	940	2213	10.53	6.2
3 <i>H</i> -1,2-dithiole	NA	288-26-6	952	7707	11.13	10.1
1,2,6,6-tetramethyl-1,3-cyclohexadiene	NA	514-96-5	985	4281	11.30	13.7
1-ethenyl-3-methylbenzene	NA	100-80-1	979	7058	11.33	3.7
1-ethenyl-2-methylbenzene	NA	611-15-4	975	6272	11.37	3.1
dimethyl trisulfide	Sulfurous, alliaceous, green, onion, vegetative	3658-80-8	970	7626	11.50	7.4
1-ethyl-4-methylbenzene	NA	622-97-9	980	3765	11.90	3.1
$\alpha$ -phellandrene	Green, citrus, woody, black pepper-like	99-83-2	1005	295	12.30	4.4
2,6-dimethylnonane	NA	17302-28-2	1016	1079	12.47	15.6
3-carene	Sweet and pungent odor citrus	13466-78-9	1011	205	12.50	4.2
1-propenylbenzene	NA	637-50-3	1011	11460	12.60	1.6
<i>o</i> -cymene	Aromatic floral	527-84-4	1022	532	12.90	5.1
cyclopropyl benzene	NA	873-49-4	1032	31140	12.93	14.2
cyclopropyl benzene	NA	873-49-4	1032	31140	12.93	14.2
cyclopropyl benzene	NA	873-49-4	1032	31140	12.93	14.2
limonene	Piny turpentine-like odor citrus	138-86-3	1030	286	13.10	4.4
eucalyptol	Eucalyptus herbal camphor	470-82-6	1032	1318	13.12	4.6
1-ethenyl-3-ethylbenzene	NA	7525-62-4	1066	39526	13.70	0.4
acetophenone	Sweet cherry pit vanilla-like	98-86-2	1065	6951	13.84	8.9
<i>n</i> -butylbenzene	NA	104-51-8	1054	740	13.90	5.2
2-methyldecane	NA	6975-98-0	1064	1286	13.90	8.2
trans-Linalool oxide (furanoid)	Sweet floral	34995-77-2	1086	205	14.00	7.3
5-ethenyltetrahydro- $\alpha,\alpha,5$ -trimethyl- cis-2-furanmethanol	Earthy floral sweet woody	5989-33-3	1074	551	14.30	6.4
diallyl disulphide	Alliaceous onion and garlic-like	2179-57-9	1081	12481	14.49	7.0
2,6-dimethyl-6-trifluoroacetoxyoctane	NA	61986-67-2	1100	170	14.50	3.3
2,6-dimethyl-6-trifluoroacetoxyoctane	NA	61986-67-2	1100	170	14.50	3.3
$\alpha,\alpha$ -dimethyl-benzene methanol	Green sweet earthy	617-94-7	1090	133094	14.55	10.0
1-methyl-4-(1-methylethylidene)-cyclohexene	Fresh woody sweet pine citrus	586-62-9	1088	847	14.70	4.7

Table 1 Continues

Identified compound name	Odor description	CAS No.	/ lit	CH/C 2DGC analysis of the sample pool		
				Peak area ( $\times 10^4$ )	$^1t_R$ (min)	$^2t_R$ (min)
4-ethenyl-1,2-dimethylbenzene	Floral	27831-13-6	1100	356	14.70	6.3
(Z)-1-allyl-2-(prop-1-en-1-yl) disulfane	NA	122156-03-0	1107	5230	14.90	6.6
linalool	Fresh floral-woody sweet citrus	78-70-6	1099	737	14.90	7.1
(E)-1-allyl-2-(prop-1-en-1-yl) disulfane	NA	122156-02-9	1103	7729	15.10	6.7
dipropyl disulfide	Sulfurous alliaceous fresh green onion	629-19-6	1107	230	15.30	5.4
1-ethyl-4-methoxybenzene	Anise	1515-95-3	1110	66893	15.50	9.1
$\alpha$ ,4-dimethyl-benzenemethanol	Menthol-like floral sweet	536-50-5	1132	30335	15.90	8.7
allyl methyl trisulfide	Creamy garlic onion	34135-85-8	1142	45717	16.24	7.8
methyl propyl trisulfide	Sulfurous onion garlic green metallic	17619-36-2	1150	1343	16.50	6.9
pentyl benzene	NA	538-68-1	1157	1308	16.70	5.2
1-phenyl-1,2-propanedione	Green plastic buttery honey pepper	579-7-0	1175	4847	17.01	5.8
3-vinyl-1,2-dithiacyclohex-4-ene	NA	62488-52-2	1198	3591	17.50	9.3
N,N-diethyl-2-methylbenzenamine	NA	606-46-2	1193	1959	17.60	6.5
N,N-diethyl-2-methylbenzenamine	NA	606-46-2	1193	1959	17.60	6.5
dodecane	Alkane-like	112-40-3	1200	1692	17.70	3.3
benzoic acid, hydrazide	NA	613-94-5	1205	2321	17.70	5.1
2-vinyl-4H-1,3-dithiine	NA	80028-57-5	1206	18559	17.70	9.1
benzaldehyde dimethyl acetal	Fruity green winey	1125-88-8	1200	72224	17.90	6.7
3,6-dimethylundecane	NA	17301-28-9	1210	441	18.50	3.8
4-ethyl-3-methylphenol	NA	1123-94-0	1237	5001	18.58	6.7
2-ethyl-6-methylphenol	NA	1687-64-5	1236	177772	18.67	6.0
2-propenyl ester benzoic acid	Sweet floral banana-like cherry	583-04-0	1254	2567	18.90	3.9
(1-methylenebutyl) benzene	NA	5676-32-4	1236	13931	18.90	4.8
1,3-bis(1,1-dimethylethyl) benzene	NA	1014-60-4	1249	6694	19.21	4.5
1-phenyl-1-butanone	Camphor cherry walnut hazelnut	495-40-9	1263	5266	19.51	3.3
3-methyl-1-phenyl-1-butanone	NA	582-62-7	1271	5513	19.71	3.1
2,6,11-trimethyldodecane	NA	31295-56-4	1275	4302	19.76	8.8
2-butyl-1-octanol	NA	3913-02-8	1277	2424	19.94	9.5
1,3,5,5-tetramethyl-1,3-cyclohexadiene	NA	4724-89-4	1292	4528	19.95	5.0

Table 1 Continues

Identified compound name	Odor description	CAS No.	/ lit	CH/C 2DGC analysis of the sample pool		
				Peak area ( $\times 10^4$ )	$^1t_R$ (min)	$^2t_R$ (min)
phenol, 2-(1-methylethyl)-, acetate	NA	1608-68-0	1277	564	20.10	5.5
anethole	Sweet anise licorice	104-46-1	1286	417	20.10	8.3
N,N-diethyl-3-methylbenzenamine	NA	91-67-8	1290	509	20.30	3.4
$\alpha$ -oxo-benzeneacetic acid methyl ester	NA	15206-55-0	1318	2824	20.42	2.3
$\alpha$ -oxo-benzeneacetic acid methyl ester	NA	15206-55-0	1318	2824	20.42	2.3
( <i>E,E</i> )-2,4-decadienal	Fatty aldehydic citrus fatty	25152-84-5	1317	1295	20.70	7.8
( <i>E</i> )-1-(prop-1-en-1-yl)-3-propyltrisulfane	NA	23838-27-9	1345	4275	20.90	11.0
2-methyl-6-propylphenol	NA	3520-52-3	1320	48747	21.10	3.5
( <i>E</i> )-1-allyl-3-(prop-1-en-1-yl)trisulfane	NA	382161-78-6	1346	736	21.10	7.8
N,N-diethyl-4-methylbenzenamine	NA	613-48-9	1343	664	21.50	2.4
2-(4-methoxyphenyl) ethanol	Aroma fresh citrus	702-23-8	1374	15291	21.90	2.8
5-methyl-1,2,3,4-tetrathiane	NA	116664-30-3	1364	3057	22.30	10.7
1-phenyl-1-pentanone	Balsamic vinegar-like	1009-14-9	1374	3442	22.40	0.3
1-(4-methoxyphenyl)-2-propanone	Sweet fruity spicy	122-84-9	1384	41527	22.45	2.2
tetradecane	Odor threshold for n-butanol	629-59-4	1400	8547	22.53	5.8
alloaromadendrene	Woody	25246-27-9	1461	2673	23.70	4.9
( <i>E</i> )- $\beta$ -famesene	Woody citrus herbal sweet	18794-84-8	1457	895	24.10	4.7
5-methyltetradecane	NA	25177-32-2	1453	2327	24.30	8.9
1-methyl-4-(6-methylhept-5-en-2-yl) cyclohexa-1,3-diene	NA	451-55-8	1480	1739	24.70	5.1
pentadecane	Waxy	629-62-9	1500	1202	24.90	3.8
1-(1,5-dimethyl-4-hexenyl)-4-methylbenzene	Herbal	644-30-4	1483	16446	24.90	5.5
[ <i>S</i> -( <i>R</i> *, <i>S</i> *)]-5-(1,5-dimethyl-4-hexenyl)-2-methyl-1,3-cyclohexadiene	Spicy fresh sharp	495-60-3	1495	16113	25.10	5.1
2-hexyl-1-decanol	NA	2425-77-6	1504	4138	25.16	5.4
2,4-ditert-butylphenol	NA	96-76-4	1519	6955	25.30	10.3
$\beta$ -bisabolene	Balsamic woody	495-61-4	1509	3607	25.50	4.9
( <i>R</i> )-1-Methyl-4-(6-methylhept-5-en-2-yl)cyclohexa-1,4-diene	NA	28976-67-2	1514	1150	25.50	5.1

Table 1 Continues

Identified compound name	Odor description	CAS No.	/ lit	CH/C 2DGC analysis of the sample pool		
				Peak area ( $\times 10^4$ )	$^1t_R$ (min)	$^2t_R$ (min)
[S-(R*,S*)]-3-(1,5-dimethyl-4-hexenyl)-6-methylene-cyclohexene	Herbal fruity woody	20307-83-9	1524	18448	25.80	5.2
1,2,3,4,4 $\alpha$ ,7-hexahydro-1,6-dimethyl-4-(1-methylethyl)-naphthalene	NA	16728-99-7	1533	15255	25.90	4.3
3,7,11-trimethyl-1-dodecanol	NA	6750-34-1	1571	2538	26.30	3.6
5-nitro-1,2,3,4-tetrahydro-naphthalene	NA	29809-14-1	1589	925	26.70	4.2
2-methyl-6-(p-tolyl) hept-2-en-4-ol	NA	38142-57-3	1583	3819	27.10	8.2
$\alpha$ R-turmerone	NA	532-65-0	1664	126223	28.90	8.2
eudesma-4(15),7-dien-1 $\beta$ -ol	NA	119120-23-9	1688	2421	29.10	0.3
(Z)- $\gamma$ -atlantone	NA	108549-48-0	1699	49843	29.10	7.3
(E)- $\gamma$ -atlantone	NA	108549-47-9	1712	83020	29.70	7.8
(E)-atlantone	NA	108645-54-1	1773	14519	31.10	8.3

Table 1 Continues

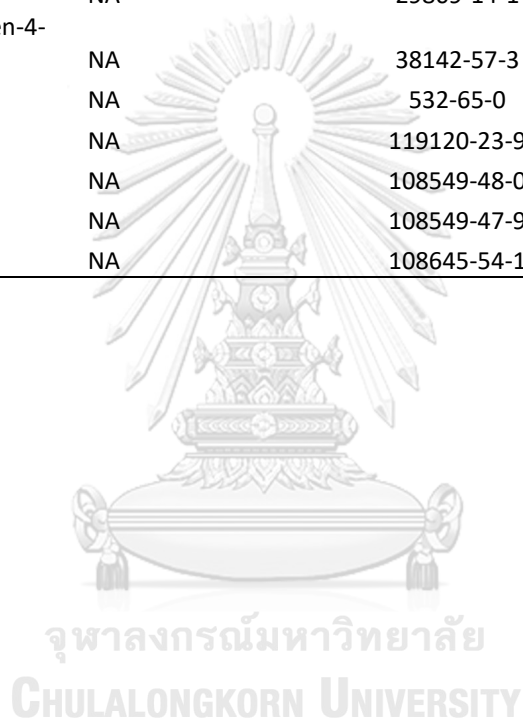

From Tables 1 most of the compounds were characteristically observed from the ingredient of yellow curry dish. For example, limonene observed in the extracted lemongrass oil [32, 33]. Linalool was identified with HS-SPME GC-MS analysis as the major volatile compounds in Kaffir lime leaf, *Citrus hystrix* (DC.) with the characteristic odor of citrus [34]. Limonene, and linalool, were reported as the components in the extracted oil of Kaffir lime leaf [35]. Limonene was also reported in swingle essential oil, with the characteristic smell of citric [36, 37].

#### 4.2 1D GC-MS with a SIM mode analysis of yellow curry samples

1D GC-MS with a SIM mode approach has been set up for all the compounds obtained from the CH/C 2DGC-MS analysis (Table 1). This was based on the compound spectra from NIST library (instead of the experimental spectra) in order to avoid selection of false positive  $m/z$  values caused by the coeluting components, such as column bleeding or any other coeluting peaks, in 2D separation. The selected  $m/z$  values were characteristic of each compound with high intensity (major abundant within each characteristic group) in order to support compound identification and lead to significantly high peak areas in SIM results. Four  $m/z$  values were selected for each compound which resulted in the total 1D SIM analysis consisting of 111  $m/z$  values of all the compounds observed with the 2D analysis. Since the applied instrument allowed only 4  $m/z$  values per injection, the overall 1DGC-MS with a SIM mode analysis of each sample was obtained by performing 5 injections. In order to provide reliable quantitative analysis as shown Figure 7 in 1D GC-MS with a SIM mode, the selected set of  $m/z$  values should also result in peak areas showing correlation with that in CH/C 2D GC-MS analysis.

The developed 1D approach was applied for analysis of three yellow curry paste samples. A volatile compound profiles were shown in Table 2 with the peak areas based on summation of the areas obtained from all four selected SIM  $m/z$  values of each compound. The example chromatograms obtained from the SIM analysis of 3-hexanol with the retention time of 6.4 min were provided in Figure 8.

Table 2 Volatile compound profiles of different yellow curry paste samples analyzed by 1D GC-MS with a SIM mode detecting four characteristic m/z values for each compound.

Identified compound name	1D GC-MS analysis							
	$t_R^a)$ (min)	Characteristic m/z				Sum of characteristic peak areas ( $\times 10^4$ )		
		1	2	3	4	Sample 1	Sample 2	Sample 3
2-hexanone	6.42	85	77	58	43	419.7	616.7	460.0
hexanal	6.42	82	72	56	43	441.9	643.7	485.1
1-methyl-Cyclopentanol	6.58	72	43	39	27	3450	777.6	4490
3-hexanol	6.41	73	58	55	31	2.58	41.56	45.27
2-hexanol	6.50	69	55	41	27	279.2	319.2	284.7
2-hydroxyethyl propanoate	6.93	75	45	29	27	1926	166.7	99.75
2,2,3,4-tetramethylpentane	7.28	57	43	39	27	137.8	353.0	244.9
3-ethyl-2,2-dimethylpentane	7.98	71	57	43	29	< 0.01	28.57	18.49
2-methyl-2-pentenal	7.84	98	69	43	39	222.9	13.85	7.434
lactic acid	7.70	56	43	29	27	< 0.01	626.3	12.99
3,4-dimethylheptane	7.98	70	57	43	29	< 0.01	23.00	15.29
2,4-dimethyl-1-heptene	8.00	71	70	55	43	1543	2593	< 0.01
3-methylbutanoic acid	7.98	56	43	41	39	< 0.01	19.52	14.01
2-methylbutanoic acid	7.98	73	57	29	27	< 0.01	20.40	7.929
diallyl sulfide	8.22	99	77	69	55	< 0.01	0.28	1.05
2,2,4-trimethylheptane	7.99	85	71	56	57	13.31	17.33	13.85
2,2,4-trimethylheptane	7.99	85	71	56	57	13.31	17.33	13.85
<i>o</i> -xylene	7.72	65	64	63	39	11.58	1.89	< 0.01
3-methyl-2-hexanol	7.80	70	55	43	27	122.4	29.67	11.80
2-heptanol	7.80	70	55	43	27	122.4	29.67	11.80
allyl methyl disulfide	6.85	120	79	45	41	293.7	2605	< 0.01
2,2-dimethyloctane	7.59	85	71	57	41	68.03	6036	14.23
2,2-dimethyloctane	7.59	85	71	57	41	68.03	6036	14.23
allylbenzene	7.94	119	115	103	75	1.197	0.75	0.43
2,2,6-trimethyloctane	8.00	85	71	57	43	1831	2622	1645
( <i>Z</i> )-1-methyl-2-(prop-1-en-1-yl) disulfane	8.45	82	77	70	69	< 0.01	0.21	< 0.01
( <i>E</i> )-1-Methyl-2-(prop-1-en-1-yl) disulfane	7.80	85	72	57	39	44.68	7.49	6.06
3 <i>H</i> -1,2-dithiole	14.0	103	80	77	39	< 0.01	0.14	0.44
1,2,6,6-tetramethyl-1,3-cyclohexadiene	14.0	136	121	105	91	< 0.01	0.20	0.72
1-ethenyl-3-methylbenzene	14.0	92	91	78	77	< 0.01	0.32	0.97
1-ethenyl-2-methylbenzene	14.0	92	91	78	77	< 0.01	0.32	0.97
dimethyl trisulfide	14.0	80	79	78	65	< 0.01	0.10	0.37



Identified compound name	1D GC-MS analysis							
	$t_R^{a)}$ (min)	Characteristic m/z				Sum of characteristic peak areas ( $\times 10^4$ )		
		1	2	3	4	Sample 1	Sample 2	Sample 3
1-ethyl-4-methylbenzene	14.0	118	117	115	91	< 0.01	0.27	< 0.01
$\alpha$ -phellandrene	15.4	136	93	77	41	< 0.01	1.04	1.30
2,6-dimethylnonane	16.9	85	70	71	55	< 0.01	0.79	0.86
3-carene	15.1	121	107	93	79	0.03	0.27	1.24
1-propenylbenzene	14.0	105	91	78	41	< 0.01	0.19	0.62
<i>o</i> -cymene	15.7	134	119	91	77	< 0.01	3.39	3.16
cyclopropyl benzene	14.0	119	103	91	79	< 0.01	0.18	0.62
cyclopropyl benzene	14.0	119	103	91	79	< 0.01	0.18	0.62
cyclopropyl benzene	14.0	119	103	91	79	< 0.01	0.18	0.62
limonene	14.0	136	107	93	65	< 0.01	0.26	1.05
eucalyptol	15.0	136	108	93	81	0.05	0.24	0.99
1-ethenyl-3-ethylbenzene	14.0	106	91	77	63	< 0.01	0.20	0.67
acetophenone	14.0	105	77	51	39	< 0.01	0.15	0.48
<i>n</i> -butylbenzene	14.0	105	91	92	65	< 0.01	0.28	0.82
2-methyldecane	14.0	77	65	41	39	< 0.01	0.14	0.50
trans-Linalool oxide (furanoid)	14.8	80	77	41	39	< 0.01	0.09	4.22
5-ethenyltetrahydro- $\alpha,\alpha,5$ -trimethyl- cis-2-furanmethanol	14.0	81	79	41	39	< 0.01	0.11	0.42
diallyl disulphide	14.8	105	81	41	39	< 0.01	0.06	2.78
2,6-dimethyl-6-trifluoroacetoxystyrene	14.8	81	51	41	39	< 0.01	0.06	2.76
2,6-dimethyl-6-trifluoroacetoxystyrene	14.8	81	51	41	39	< 0.01	0.06	2.76
$\alpha,\alpha$ -dimethyl-benzene methanol	14.8	121	118	77	43	< 0.01	0.13	2.70
1-methyl-4-(1-methylethylidene)-cyclohexene	15.3	136	121	93	79	0.03	0.24	0.14
4-ethenyl-1,2-dimethylbenzene	14.6	105	103	91	78	< 0.01	0.17	2.29
( <i>Z</i> )-1-Allyl-2-(prop-1-en-1-yl)disulfane	14.8	107	105	81	41	< 0.01	0.09	2.47
linalool	14.8	121	107	93	39	< 0.01	0.25	7.60
( <i>E</i> )-1-Allyl-2-(prop-1-en-1-yl)disulfane	16.0	105	79	41	39	< 0.01	0.56	1.75
disulfide dipropyl	15.7	43	41	39	27	< 0.01	0.51	2.81
1-ethyl-4-methoxybenzene	15.7	136	121	91	77	< 0.01	3.63	4.90
$\alpha,4$ -dimethyl-benzenemethanol	16.1	136	121	93	43	0.03	2.97	7.28
allyl methyl trisulfide	16.9	111	79	45	39	< 0.01	0.77	1.67
methyl propyl trisulfide	16.9	154	79	43	41	< 0.01	1.79	2.37
pentyl benzene	16.7	105	91	78	65	< 0.01	2.49	1.05
1-phenyl-1,2-propanedione	18.2	77	43	39	27	< 0.01	1.52	0.35
3-vinyl-1,2-dithiacyclohex-4-ene	17.6	85	71	70	57	< 0.01	0.10	0.06

Table 2 Continues

Identified compound name	1D GC-MS analysis							
	$t_R^{a)}$ (min)	Characteristic m/z				Sum of characteristic peak areas ( $\times 10^4$ )		
		1	2	3	4	Sample 1	Sample 2	Sample 3
N,N-diethyl-2-methylbenzenamine	16.9	134	119	108	69	< 0.01	1.67	1.40
N,N-diethyl-2-methylbenzenamine	16.9	134	119	108	69	< 0.01	1.67	1.40
dodecane	17.6	85	71	57	43	< 0.01	0.13	0.07
benzoic acid, hydrazide	18.2	136	105	77	51	< 0.01	3.23	0.57
2-vinyl-4 <i>H</i> -1,3-dithiine	16.9	111	103	97	72	< 0.01	0.52	0.63
benzaldehyde dimethyl acetal	17.7	121	105	77	75	< 0.01	3.31	1.26
3,6-dimethylundecane	16.2	113	99	71	57	186.1	815.9	425.6
4-ethyl-3-methylphenol	18.6	136	121	91	77	< 0.01	5.58	0.94
2-ethyl-6-methylphenol	18.6	136	121	91	77	< 0.01	5.58	0.94
2-propenyl ester benzoic acid	18.6	106	105	103	77	< 0.01	1.68	0.22
(1-methylenebutyl) benzene	18.6	91	77	51	27	< 0.01	2.59	< 0.01
1,3-bis(1,1-dimethylethyl) benzene	20.3	91	65	50	39	< 0.01	0.08	< 0.01
1-phenyl-1-butanone	20.4	105	77	51	50	< 0.01	0.08	< 0.01
3-methyl-1-phenyl-1-butanone	18.6	120	105	78	77	< 0.01	1.72	0.21
2,6,11-trimethyldodecane	19.9	55	43	41	39	< 0.01	1.10	0.51
2-butyl-1-octanol	20.7	97	69	55	39	< 0.01	0.21	0.19
1,3,5,5-tetramethyl-1,3-cyclohexadiene	18.6	91	77	55	41	< 0.01	2.85	< 0.01
phenol, 2-(1-methylethyl)-, acetate	20.7	107	95	91	79	< 0.01	0.32	0.21
anethole	20.7	91	77	65	39	< 0.01	0.11	0.28
N,N-diethyl-3-methylbenzenamine	20.7	91	81	65	51	< 0.01	0.23	0.21
$\alpha$ -oxo-benzeneacetic acid methyl ester	20.3	77	73	65	51	< 0.01	0.18	< 0.01
$\alpha$ -oxo-benzeneacetic acid methyl ester	20.3	77	73	65	51	< 0.01	0.18	< 0.01
( <i>E,E</i> )-2,4-decadienal	20.7	95	81	41	39	< 0.01	0.66	0.35
( <i>E</i> )-1-(prop-1-en-1-yl)-3-propyltrisulfane	20.7	69	55	41	39	< 0.01	0.36	0.42
2-methyl-6-propylphenol	12.1	150	91	77	51	1354	682.4	1019
( <i>E</i> )-1-allyl-3-(prop-1-en-1-yl)trisulfane	20.7	81	55	41	39	< 0.01	0.46	0.38
N,N-diethyl-4-methylbenzenamine	20.3	163	148	120	91	< 0.01	0.46	< 0.01
2-(4-methoxyphenyl) ethanol	20.7	91	77	55	41	< 0.01	0.28	0.42
5-methyl-1,2,3,4-tetrathiane	20.3	108	91	80	41	< 0.01	0.40	0.23
1-phenyl-1-pentanone	27.0	79	77	65	41	< 0.01	1.09	0.08
1-phenyl-1-pentanone	27.0	79	77	65	41	< 0.01	1.09	0.08

Table 2 Continues

Identified compound name	1D GC-MS analysis							
	$t_R$ <sup>a)</sup> (min)	Characteristic m/z				Sum of characteristic peak areas ( $\times 10^4$ )		
		1	2	3	4	Sample 1	Sample 2	Sample 3
1-(4-methoxyphenyl)-2-propanone	20.7	91	77	65	51	< 0.01	0.08	0.22
tetradecane	22.5	70	56	43	41	< 0.01	0.11	0.40
alloaromadendrene	20.9	70	57	43	41	< 0.01	0.16	< 0.01
( <i>E</i> )- $\beta$ -farnesene	23.8	71	70	43	41	< 0.01	0.16	< 0.01
5-methyltetradecane	26.0	154	85	57	43	< 0.01	0.12	< 0.01
1-methyl-4-(6-methylhept-5-en-2-yl) cyclohexa-1,3-diene	25.5	146	104	94	41	< 0.01	0.45	0.04
pentadecane	24.0	85	71	57	43	0.06	0.22	0.21
1-(1,5-dimethyl-4-hexenyl)-4-methyl benzene	25.5	146	104	94	41	< 0.01	0.45	0.04
[ <i>S</i> -( <i>R</i> *, <i>S</i> *)]-5-(1,5-dimethyl-4-hexenyl)-2-methyl-1,3-cyclohexadiene	26.9	204	119	93	41	< 0.01	0.96	0.20
2-hexyl-1-decanol	24.0	85	71	57	43	0.06	0.22	0.21
2,4-ditert-butylphenol	25.0	147	73	75	57	< 0.01	0.10	< 0.01
$\beta$ -Bisabolene	25.9	133	105	57	43	< 0.01	0.13	< 0.01
( <i>R</i> )-1-methyl-4-(6-methylhept-5-en-2-yl) cyclohexa-1,4-diene	25.9	133	105	57	43	< 0.01	0.13	< 0.01
[ <i>S</i> -( <i>R</i> *, <i>S</i> *)]-3-(1,5-dimethyl-4-hexenyl)-6-methylene-cyclohexene	25.0	147	112	71	57	< 0.01	0.04	< 0.01
1,2,3,4,4 $\alpha$ ,7-hexahydro-1,6-dimethyl-4-(1-methylethyl)-naphthalene	25.9	159	129	71	57	< 0.01	0.10	< 0.01
3,7,11-trimethyl-1-dodecanol	22.9	97	83	69	55	240.4	5145	2614
5-nitro-1,2,3,4-tetrahydro-naphthalene	27.4	159	128	115	91	186.5	5062	764.2
2-methyl-6-( <i>p</i> -tolyl) hept-2-en-4-ol	27.5	119	117	91	77	0.05	0.93	< 0.01
<i>aR</i> -turmerone	29.3	132	119	91	83	0.29	4.11	3.31
eudesma-4(15),7-dien-1 $\beta$ -ol	29.0	177	159	81	41	< 0.01	0.66	< 0.01
( <i>Z</i> )- $\gamma$ -atlantone	29.2	119	105	83	55	0.29	3.74	2.13
( <i>E</i> )- $\gamma$ -atlantone	29.7	119	105	83	55	0.25	3.74	2.40
( <i>E</i> )-atlantone	31.2	135	120	105	77	< 0.01	0.24	< 0.01

Table 2 Continues

<sup>a)</sup> The average retention time of four  $m/z$  values were selected for each compound.

For an example of 3-hexanol, 4  $m/z$  values of 73, 58, 55 and 31 were selected and 4 chromatograms with the different particular  $t_R$  and peak area were displayed as shown in Figures 8A-D. The peak area value of this compound in Table 2 was obtained by summation of the areas of all the peaks at the average  $t_R$  of 6.4 min in Figures 8A-D, were the average  $t_R$  from 4 chromatograms. Since several compounds could share the same  $m/z$  value, each SIM analysis selecting a  $m/z$  value resulted in several peaks in Figure 8A. This caused difficulty in identification of all the SIM peaks of each compound. Note that the  $^1t_R$  in the 2D analysis could not be accurately applied as the reference for peak identification with the 1D GC-SIM MS analysis due to the retention time shift caused by different inlet and outlet pressures of the applied nonpolar columns. However, reliable identification of SIM peaks of a compound could be performed according to retention index of this compound. To this end, retention indices of all the peaks observed in Figure 8 were calculated. The SIM peaks at 6.4 min in Figures 8A-D were identified for 3-hexanol since they were observed with the same retention time and peak shape and showed the calculated values closely to the target value of 3-hexanol.

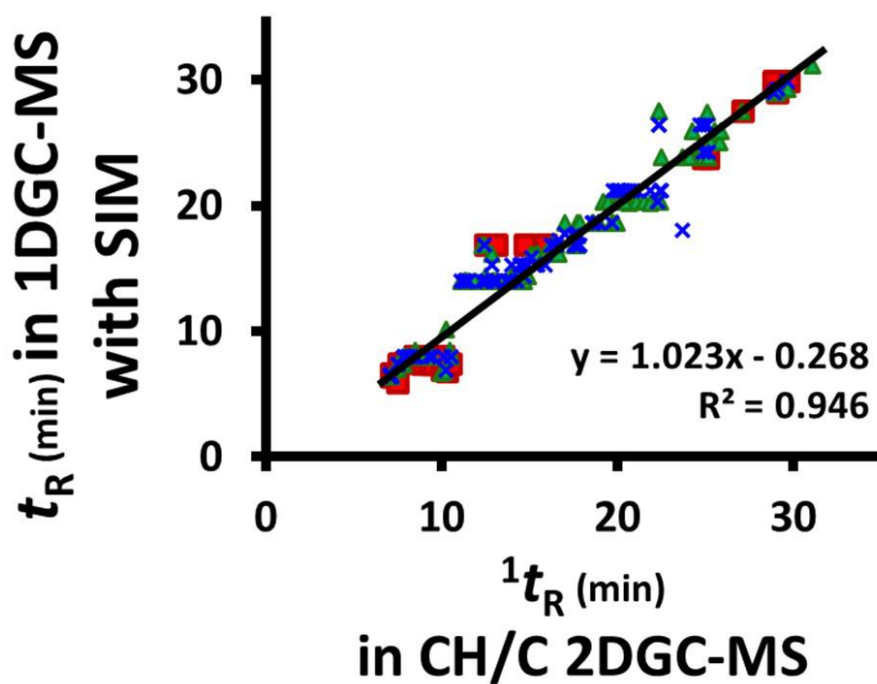

Figure 7 Correlation between x-axis:  ${}^1D$  retention time values obtained from CH/C 2D GC analysis of a volatile compounds in the pool sample and y-axis: retention time values obtained from 1D GC-MS with a SIM mode analysis of the same compounds in the yellow curry paste sample 1-3 ( $\square$ ,  $\times$  and  $\Delta$ , respectively).

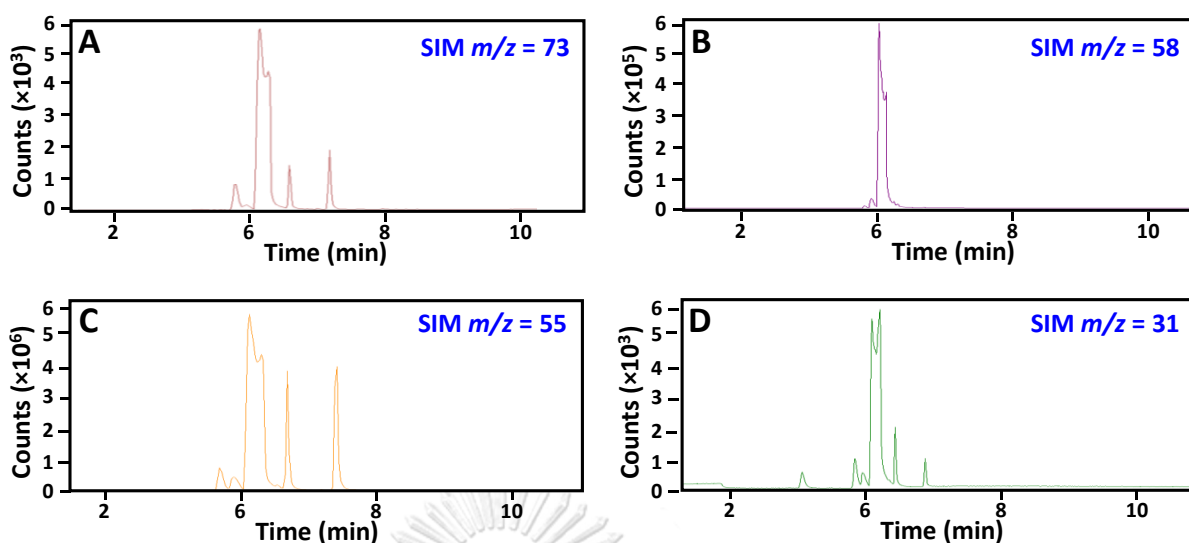

Figure 8 GC-SIM MS results of a yellow curry paste sample using different  $m/z$  values of 73 58 55 31, A-D respectively.

From Figure 6, the total peak capacity from CH/C 2D GC-MS analysis was approximated as 2080. This is calculated from  $^1n_c$  of 52 (with average peak width, maximum  $t_R$ , and minimum  $t_R$  of 0.4, 22.00 and 1.60 min, respectively) and  $^2n_c$  of 40 (with average 2D peak width and  $^2t_R$  range of 0.13 and 5.00 min, respectively). The peak capacity of 52 was also approximated for the conventional 1D full scan GC-MS analysis. From 1D GC-MS with a SIM mode shown in Figure 8 the peak capacity from can be approximated as 1207. This contributed from 17 (from total number of SIM divided by 4  $m/z$  per each compound) times 71 (from average peak width of 0.35 min, the first and latest eluting peak retention times of 6.41 and 31.20, respectively).

Although lower peak capacity was approximated from 1D GC-MS with a SIM mode, this was sufficient for analysis of the samples. Although the same number of compounds could be obtained analyzed compared with the CH/C 2D GC-MS analysis, the analysis times and repeatability could also be expected to be better with less complicated experimental setup of the 1D GC-MS with a SIM mode analysis. In this study.

## CHAPTER V

### CONCLUSION

In this thesis, the 1DGC approach combined with mass spectrometry with selected ion monitoring (SIM) operation was developed and applied for analysis of volatile compounds in yellow curry pastes. In order to improve analysis of analytes. Firstly, CH/C 2D GC-MS with a restrictor column (1.5 m x 0.1 mm) was established for the analysis of yellow curry paste samples using an HP-5MS capillary column (30 m x 0.25 mm i.d., 0.25  $\mu\text{m}$  film thickness), and a DB-WAX capillary column (60 m x 0.25 mm x 0.25  $\mu\text{m}$ ) as the <sup>1</sup>D and <sup>2</sup>D columns, respectively. Based on retention index from the DB-WAX capillary column and mass spectra from MS library match, The total profiles and were obtained 119 identified volatile compounds in the yellow curry paste sample were obtained in an MS full scan mode. The major components based on the peak area percentages were 2,2,3,4-tetramethyl pentane (18 %),  $\alpha,\alpha$ -dimethyl-benzene methanol (6 %) and 2-ethyl-6-methylphenol (8 %) which contributed to the smells of not available, green, sweet and not available, respectively.

Secondly, 1D GC-MS with a SIM mode was performed using the HP-5MS capillary column (30 m x 0.25 mm i.d., 0.25  $\mu\text{m}$  film thickness). Using the information from CH/C 2D GC-MS, the selected  $m/z$  values for 1D GC-MS were characteristic of each compound with high intensity (major abundant within each characteristic group) in order to support compound identification and lead to significantly high peak areas in SIM results. Four  $m/z$  values were selected for each compound which resulted in the total 1D SIM analysis consisting of 111  $m/z$  values of all the compounds observed with the 2D analysis. This offers effective untargeted analysis performance similar to that provided by high performance CH/C 2D GC-MS technique. This 1D GC-MS with a SIM mode clearly improves the performance of the separation increasing the capability of mass spectrometry with larger number of identified compounds using SIM mode compared with conventional 1D GC-MS

approach with full scan operation. Furthermore, this reduces analysis times from 25 injections with the CH/C 2D GC-MS to 5 injections for 1D GC-MS because of performance of the program in GC-MS with a SIM mode was set at 20 m/z /rounds and reduced the weight of sample from 2g (CH/C 2D GC-MS) in order to increase concentration of sample and observe profile of yellow curry paste to 1g (1D GC-MS with a SIM mode). This is also expected to provide improved repeatability compared with the CH/C 2DGC technique. In addition, 1D GC-MS with a SIM mode along with information from CH/C 2D GC-MS with a full scan mode may be applied to other samples.





## REFERENCES

- [1] Jiang, B., Tsao, R., Li, Y., Miao, M., Food Safety: Food Analysis Technologies/Techniques. 2014.
- [2] Feng, T., Sun, M., Song, S., Zhuang, H., Yao, L., in: Zhong, J., Wang, X. (Eds.), Evaluation Technologies for Food Quality. Woodhead Publishing, 2019, pp. 219-265.
- [3] Kanchanakunjara, T., Chantachon, S., Koseyayotin, M., The Evolution of Thai Curry Pastes *Dusit Thani College Journal Vol.11*. 2560.
- [4] Guo, M., in: Guo, M. (Ed.), Functional Foods. Woodhead Publishing, 2009, pp. 9-61.
- [5] Molina-Calle, M., Priego-Capote, F., Luque de Castro, M. D., Headspace-GC-MS volatile profile of black garlic vs fresh garlic: Evolution along fermentation and behavior under heating. *LWT*. 2017, *80*, 98-105.
- [6] Bonaduce, I., Colombini, M. P., Diring, S., Identification of garlic in old gildings by gas chromatography-mass spectrometry. *Journal of Chromatography A*. 2006, *1107*, 226-232.
- [7] Majchrzak, T., Kalinowska, K., Lubinska-Szczygeł, M., Róžańska, A., Dymerski, T., Wardencki, W., Namieśnik, J., Recent Applications of 1D GC-MS and 2D GC-MS in Foodomics Studies. 2020.
- [8] Ruiz-Samblás, C., González-Casado, A., Cuadros-Rodríguez, L., García, F. P. R., Application of selected ion monitoring to the analysis of triacylglycerols in olive oil by high temperature-gas chromatography/mass spectrometry. *Talanta*. 2010, *82*, 255-260.
- [9] Sneddon, J., Masuram, S., Richert, J., Gas chromatography-mass spectrometry-basic principles, instrumentation and selected applications for detection of organic compounds. *Analytical letters*. 2007, *40*, 1003-1012.
- [10] Thurnhofer, S., Vetter, W., A Gas Chromatography/Electron Ionization-Mass Spectrometry-Selected Ion Monitoring Method for Determining the Fatty Acid Pattern in Food after Formation of Fatty Acid Methyl Esters. *Journal of Agricultural and Food Chemistry*. 2005, *53*, 8896-8903.
- [11] Clench, M. R., Tetler, L. W., in: Wilson, I. D. (Ed.), Encyclopedia of Separation

Science. Academic Press, Oxford 2000, pp. 448-455.

[12] Kaklamanos, G., Aprea, E., Theodoridis, G., in: Pico, Y. (Ed.), *Chemical Analysis of Food* (Second Edition). Academic Press, 2020, pp. 525-552.

[13] De Hoffmann, E., Stroobant, V., *Mass spectrometry: principles and applications*. John Wiley & Sons, 2007.

[14] Smith, R. W., in: Siegel, J. A., Saukko, P. J., Houck, M. M. (Eds.), *Encyclopedia of Forensic Sciences* (Second Edition). Academic Press, Waltham 2013, pp. 603-608.

[15] Geer Wallace, M. A., Pleil, J. D., Mentese, S., Oliver, K. D., Whitaker, D. A., Fent, K. W., Calibration and performance of synchronous SIM/scan mode for simultaneous targeted and discovery (non-targeted) analysis of exhaled breath samples from firefighters. *J Chromatogr A*. 2017, *1516*, 114-124.

[16] Canini, A., Alesiani, D., D'Arcangelo, G., Tagliatesta, P., Gas chromatography–mass spectrometry analysis of phenolic compounds from *Carica papaya* L. leaf. *Journal of Food Composition and Analysis*. 2007, *20*, 584-590.

[17] Li, B., Dunham, S. J. B., Dong, Y., Yoon, S., Zeng, M., Sweedler, J. V., Analytical capabilities of mass spectrometry imaging and its potential applications in food science. *Trends in Food Science & Technology*. 2016, *47*, 50-63.

[18] Ahmida, H. S. M., Bertucci, P., Franzò, L., Massoud, R., Cortese, C., Lala, A., Federici, G., Simultaneous determination of plasmatic phytosterols and cholesterol precursors using gas chromatography–mass spectrometry (GC–MS) with selective ion monitoring (SIM). *Journal of Chromatography B*. 2006, *842*, 43-47.

[19] Marriott, P. J., Chin, S.-T., Maikhunthod, B., Schmarr, H.-G., Bieri, S., Multidimensional gas chromatography. *TrAC Trends in Analytical Chemistry*. 2012, *34*, 1-21.

[20] Marriott, P., Shellie, R., Principles and applications of comprehensive two-dimensional gas chromatography. *TrAC Trends in Analytical Chemistry*. 2002, *21*, 573-583.

[21] Dymerski, T., Two-dimensional gas chromatography coupled with mass spectrometry in food analysis. *Critical reviews in analytical chemistry*. 2018, *48*, 252-278.

[22] Han, Y., Zhang, Y., Liu, H., in: Worsfold, P., Poole, C., Townshend, A., Miró, M.

(Eds.), *Encyclopedia of Analytical Science* (Third Edition). Academic Press, Oxford 2019, pp. 237-244.

[23] Evers, R., Development of a Liquid Chromatography Ion Trap Mass Spectrometer Method for Clinical Drugs of Abuse Testing with Automated On-Line Extraction Using Turbulent Flow Chromatography. 2014.

[24] Seeley, J. V., Micyus, N. J., Bandurski, S. V., Seeley, S. K., McCurry, J. D., Microfluidic deans switch for comprehensive two-dimensional gas chromatography. *Analytical chemistry*. 2007, 79, 1840-1847.

[25] Wang, F. C.-Y., New valve switching modulator for comprehensive two-dimensional gas chromatography. *Journal of Chromatography A*. 2008, 1188, 274-280.

[26] Jiang, M., Kulsing, C., Nolvachai, Y., Marriott, P. J., Two-Dimensional Retention Indices Improve Component Identification in Comprehensive Two-Dimensional Gas Chromatography of Saffron. *Analytical Chemistry*. 2015, 87, 5753-5761.

[27] Kulsing, C., Nolvachai, Y., Wong, Y. F., Glouzman, M. I., Marriott, P. J., Observation and explanation of two-dimensional interconversion of oximes with multiple heart-cutting using comprehensive multidimensional gas chromatography. *Journal of Chromatography A*. 2018, 1546, 97-105.

[28] Nolvachai, Y., Kulsing, C., Marriott, P. J., Multidimensional gas chromatography in food analysis. *TrAC Trends in Analytical Chemistry*. 2017, 96, 124-137.

[29] Tranchida, P. Q., Donato, P., Cacciola, F., Beccaria, M., Dugo, P., Mondello, L., Potential of comprehensive chromatography in food analysis. *TrAC Trends in Analytical Chemistry*. 2013, 52, 186-205.

[30] Douglas, D. J., Linear quadrupoles in mass spectrometry. *Mass spectrometry reviews*. 2009, 28 6, 937-960.

[31] Wang, B., Shen, H., Fang, A., Huang, D.-S., Jiang, C., Zhang, J., Chen, P., A regression model for calculating the second dimension retention index in comprehensive two-dimensional gas chromatography time-of-flight mass spectrometry. *J Chromatogr A*. 2016, 1451, 127-134.

[32] Schaneberg, B. T., Khan, I. A., Comparison of Extraction Methods for Marker Compounds in the Essential Oil of Lemon Grass by GC. *Journal of Agricultural and Food Chemistry*. 2002, 50, 1345-1349.

- [33] Kumar, V., Tewari, R., Singh, K., Comparative studies of drying methods on yield and composition of the essential oil of *Cymbopogon citratus*. *Journal of Essential Oil Bearing Plants*. 2015, 18, 744-750.
- [34] Wongpornchai, S., in: Handbook of Herbs and Spices: Second Edition. 2012, pp. 319-328.
- [35] Jirapakkul, W., Tinchan, P., Chaiseri, S., Effect of drying temperature on key odourants in kaffir lime (*Citrus hystrix* D.C., Rutaceae) leaves. *International Journal of Food Science and Technology*. 2013, 48, 143-149.
- [36] Cruz-Valenzuela, M. R., Tapia-Rodríguez, M. R., Vazquez-Armenta, F. J., Silva-Espinoza, B. A., Ayala-Zavala, J. F., in: Preedy, V. R. (Ed.), Essential Oils in Food Preservation, Flavor and Safety. Academic Press, San Diego 2016, pp. 531-537.
- [37] Ramesh Yadav, A., Chauhan, A. S., Rekha, M. N., Rao, L. J. M., Ramteke, R. S., Flavour quality of dehydrated lime [*Citrus aurantifolia* (Christm.) Swingle]. *Food Chemistry*. 2004, 85, 59-62.



จุฬาลงกรณ์มหาวิทยาลัย  
**CHULALONGKORN UNIVERSITY**

**VITA**

**NAME** Natsuda Singtothong

**DATE OF BIRTH** 09 Dec 1994

**PLACE OF BIRTH** Bangkok

**INSTITUTIONS ATTENDED** Ramkhamhaeng University

**HOME ADDRESS** 42/141 Casaleena2 Nimitmai Road. Nimitmail20 Soi.  
Saikongdin Klong Sam Wa Bangkok 10510.

